

President - Texas
AT&T Texas
Dallas, Texas
Issued: May 9, 2024
Effective: May 10, 2024

ACCESS SERVICE TARIFF
Section: 6
Sheet: 1
Revision: 9
Replacing: 8

Replacing: 9 Sheet 3
Replacing: 7 Sheet 3.1
Replacing: 5 Sheet 4
Replacing: 4 Sheet 4.1
Replacing: 4 Sheet 5
Replacing: 5 Sheet 6
Replacing: 6 Sheet 7
Replacing: 6 Sheet 8
Replacing: 9 Sheet 9
Replacing: 7 Sheet 10
Replacing: 9 Sheet 11
Replacing: 11 Sheet 12
Replacing: 8 Sheet 13
Replacing: 7 Sheet 14
Replacing: 6 Sheet 15
Replacing: 5 Sheet 16
Replacing: 7 Sheet 17
Replacing: 5 Sheet 18
Replacing: 5 Sheet 19
Replacing: 6 Sheet 20
Replacing: 7 Sheet 21
Replacing: 7 Sheet 21.1
Replacing: 4 Sheet 21.2
Replacing: 4 Sheet 21.3
Replacing: 4 Sheet 21.4
Replacing: 4 Sheet 21.5
Replacing: 5 Sheet 21.6
Replacing: 6 Sheet 22
Replacing: 8 Sheet 23
Replacing: 5 Sheet 23.1
Replacing: 4 Sheet 24
Replacing: 4 Sheet 25
Replacing: 5 Sheet 26
Replacing: 6 Sheet 27
Replacing: 4 Sheet 27.1
Replacing: 3 Sheet 27.2
Replacing: 4 Sheet 28

SWITCHED ACCESS SERVICE

President - Texas
AT&T Texas
Dallas, Texas
Issued: May 9, 2024
Effective: May 10, 2024

ACCESS SERVICE TARIFF
Section: 6
Sheet: 2
Revision: 10
Replacing: 9

SWITCHED ACCESS SERVICE

This section concurs in Southwestern Bell Telephone Company, LLC's (T)
(SWBT's) Tariff FCC No. 1, Section 6, which can be accessed via the (C)
following hypertext link to AT&T Texas' commercial website:

<http://cpr.att.com/pdf/fcc-swbt/1006.pdf> (T)

SPECIAL ACCESS SERVICE

Sheet

7.	Special Access Service	4
7.1	Service Provisioning	4
7.1.1	Types of Service Configurations	5
(A)	Two-Point Service.....	5
(B)	Multipoint Service.....	5
(C)	Multiplexed Service.....	5
(D)	WATS Access Line Service.....	6
(E)	(Reserved for Future Use).....	6
7.1.2	Types of Channels	7
7.1.3	Hubs	8
(A)	General.....	8
(B)	Types of Hubs.....	8
7.1.4	Ordering Options and Provisions	10
7.1.5	Alternate Use	11
7.1.6	Special Facilities Routing	12
7.1.7	Acceptance Testing	13
7.1.8	Design Layout Report	14
7.2	Rate Regulations	15
7.2.1	Rate Elements	16
(A)	Channel Termination.....	16
(B)	Channel Mileage.....	16
(C)	Optional Features and Functions.....	16
(D)	(Reserved for Future Use).....	16
(E)	Availability and Allowance for Interruption on 1.544 Mbps Access Service.....	17
7.2.2	Monthly Rates	18
7.2.3	(Reserved for Future Use)	19
7.2.4	Nonrecurring Charges	20
(A)	Installation of Service.....	20
(B)	Installation of Optional Features and Functions.....	20
(C)	(Reserved for Future Use).....	20
(D)	Service Rearrangements.....	20
7.2.5	Surcharge for Special Access Service	23
(A)	General Description.....	23
(B)	Exemption Certification.....	23
(C)	Surcharge Credits.....	24
(D)	Surcharge Billing.....	24
7.2.6	Mileage Measurement	25
7.2.7	Moves	26
(A)	Moves of the Point of Termination Within the Same Customer Premises.....	26
(B)	Moves of a Customer Premises.....	26

SPECIAL ACCESS SERVICE

	<u>Sheet</u>
7.2 <u>Rate Regulations (cont'd)</u>	
7.2.8 Minimum Periods.....	27
7.2.9 Facility Hubs	28
7.2.10 Shared Use Analog and Digital High Capacity Services.....	29
7.2.11 WATS Access Lines.....	30
7.2.12 Two-Point Service	31
7.2.13 Multipoint Service.....	32
7.2.14 Multiplexed Service	34
7.2.15 Alternate Use.....	35
7.2.16 Customized Channels.....	36
7.2.17 Message Station Equipment Recovery Charge.....	37
7.2.18 (Reserved for Future Use).....	38
7.2.19 (Reserved for Future Use).....	39
7.2.20	
7.2.21 Reserved for future use.....	40.1
7.2.22 High Capacity Pricing Plan (HC-TPP).....	40.3
A. General Description.....	40.3
B. Services Available Under HC-TPP.....	40.3
C. Terms and Conditions.....	40.4
D. Rate Applications.....	40.9
E. (Reserved for Future Use).....	40.9
7.3 <u>Service Descriptions, Rates and Charges</u>	41
7.3.1 General.....	41
A. Descriptions.....	41
B. Technical Specifications Packages.....	41
C. Channel Interfaces.....	42
D. Optional Features and Functions.....	43
7.3.2 Metallic Service.....	44
A. Basic Channel Description.....	44
B. Technical Specifications Packages.....	44
C. Channel Interfaces (CI).....	44
D. Optional Features and Functions.....	44
E. Rates and Charges.....	45
7.3.3 Telegraph Service.....	46
A. Basic Channel Description.....	46
B. Technical Specifications Packages.....	46
C. Channel Interfaces (CI).....	46
D. (Reserved for Future Use).....	47
E. Rates and Charges.....	47

President - Texas
AT&T Texas
Dallas, Texas
Issued: May 9, 2024
Effective: May 10, 2024

ACCESS SERVICE TARIFF
Section: 7
Sheet: 2.1
Revision: 3
Replacing: 2

SPECIAL ACCESS SERVICE

	<u>Sheet</u>
7.2 Rate Regulations (Cont'd)	
7.3 Service Descriptions, Rates and Charges (Cont'd)	
7.3.4 Voice Grade Service	48
(A) Basic Channel Descriptions	48
(B) Technical Specifications Packages	49
(C) Channel Interfaces (CI)	49
(D) Reserved for Future Use)	49
(E) Four-wire/Two-wire Conversion	49
(F) Optional Features and Functions	50
(G) Rates and Charges	54

SPECIAL ACCESS SERVICE

Sheet

7.3 Service Descriptions, Rates and Charges (cont'd)

7.3.5	Reserved for future use.....	59
7.3.6	Reserved for future use.....	62
7.3.7	Reserved for future use.....	63
7.3.8	Reserved for future use.....	66
7.3.9	Digital Link Service.....	68
A.	Basic Channel Descriptions.....	69
B.	Technical Specifications Packages.....	69
C.	Channel Interfaces (CI).....	69
D.	(Reserved for Future Use).....	69
E.	Optional Features and Functions.....	69
F.	Rates and Charges.....	70
7.3.10	High Capacity Service.....	73
A.	Basic Channel Descriptions.....	73
B.	Technical Specifications Package.....	73
C.	Channel Interfaces (CI).....	73
D.	(Reserved for Future Use).....	73
E.	Optional Features and Functions.....	73
F.	Rates and Charges.....	76

President - Texas
AT&T Texas
Dallas, Texas
Issued: May 9, 2024
Effective: May 10, 2024

ACCESS SERVICE TARIFF
Section: 7
Sheet: 3.1
Revision: 4
Replacing: 3

SPECIAL ACCESS SERVICE

Sheet

7.3 Service Descriptions, Rates and Charges (cont'd)

7.4 <u>Miscellaneous Rates and Charges</u>	79
A. Rollover.....	79
B. Special Access Surcharge.....	79
C. Message Station Equipment Recovery Charge.....	79
D. Access Order Charge.....	79
E. Service Rearrangement Charge.....	79
7.5 <u>(Reserved for Future Use)</u>	80

SPECIAL ACCESS SERVICE

7. Special Access Service

7.1 Service Provisioning

Special Access Service includes all exchange access not using SWBT end office switches.

- Special Access Service, with the exception of the WATS Access Line{2}, Network Reconfiguration Service and Transport Resource Management Service, provides a transmission path connecting customer designated premises {1}, either directly or through a SWBT hub where bridging, multiplexing, Network Reconfiguration Service or Transport Resource Management Service functions are performed. (Network Reconfiguration Service and Transport Resource Management Service, as set forth in Section 18, work in conjunction with Special Access Service allowing customers the ability to reconfigure their circuits.)
- The WATS Access Line{2}, offered under Voice Grade{2} Service, provides a transmission path connecting a customer designated premises with the WATS serving office.

The connections provided by Special Access Service can be either analog or digital. Analog connections are differentiated by spectrum and bandwidth. Digital connections are differentiated by bit rate.

- {1} SWBT Centrex CO-like switches and SWBT Answering Service Concentrators are considered to be customer premises for purposes of administering regulations and rates contained in this tariff.
- {2} Effective June 30, 2021, this Service will no longer be available for purchase by new or existing customers. In addition, requests to move, add, change, or renew existing service arrangements will not be accepted. Following the expiration of a customer's existing term agreement, service will be provided on a month-to-month basis at the applicable Monthly rates until the service is discontinued. The Company currently plans to discontinue this service on or after June 30, 2024.

SPECIAL ACCESS SERVICE

7.1 Service Provisioning (Cont'd)

7.1.1 Types of Service Configurations

There are types of service configurations over which Special Access Services are provided, as shown following.

(A) Two Point Service

A two-point service connects two customer designated premises, either on a directly connected basis or through a hub where multiplexing, Network Reconfiguration Service or Transport Resource Management Service functions are performed.

(B) Multipoint Service

Multipoint service connects three or more customer designated premises through a SWBT hub.

Only certain types of Special Access Service are provided as multipoint service. These are so designated in the Service Descriptions set forth in 7.3 (Service Description, Rates and Charges).

There is no limitation on the number of mid-links (channels between hubs) available with multipoint service. However, when more than three mid-links are provided in tandem, the quality of the service may be degraded.

Multipoint service using a customized technical specifications package, as set forth in 7.3 (Service Description, Rates and Charges), will be provided when technically possible. If SWBT determines that the requested characteristics for a multipoint service are not compatible, the customer will be advised and given the opportunity to change the order.

(C) Multiplexed Service

Multiplexed service is an arrangement that allows the conversion of Voice Grade⁽¹⁾, Analog⁽¹⁾, and Digital High Capacity facilities to lower capacity or bandwidth. The types of multiplexing available are as follows:

- (1) Voice Grace to Telegraph⁽¹⁾ (43 Type Carrier)
An arrangement that converts a Voice Grade channel to Telegraph Grade channels using frequency division multiplexing.
- (2) Wideband Analog⁽²⁾ Mastergroup to Supergroup
- (3) Wideband Analog⁽²⁾ Supergroup to Group
- (4) Wideband Analog⁽²⁾ Group to Voice Grade
An arrangement that converts a Group channel to twelve Voice Grade⁽¹⁾ channels using frequency division multiplexing.

(1) Effective June 30, 2021, this Service will no longer be available for purchase by new or existing customers. In addition, requests to move, add, change, or renew existing service arrangements will not be accepted. Following the expiration of a customer's existing term agreement, service will be provided on a month-to-month basis at the applicable Monthly rates until the service is discontinued. The Company currently plans to discontinue this service on or after June 30, 2024.

(2) Wideband Services were previously removed effective November 11, 2014.

SPECIAL ACCESS SERVICE

7.1 Service Provisioning (Cont'd)

7.1.1 Types of Service Configurations (Cont'd)

(C) Multiplexed Service (Cont'd)

(6) High Capacity (DS1) to Voice Grade

An arrangement that converts a 1.544 Mbps channel to 24 channels for use with Voice Grade services⁽¹⁾. A channel of this DS1 to the hub can also be used for Digital Link⁽¹⁾ Metallic service⁽¹⁾ or WATS Access Lines⁽¹⁾.

(7) High Capacity (DS1) to DSO

An arrangement that converts a 1.544 Mbps channel to 23 64.0 kbps channels using digital time division multiplexing.

(8) High Capacity DSO to Subrate⁽¹⁾

An arrangement that converts a 64.0 kbps channel to subspeeds of up to twenty 2.4 kbps, ten 4.8 kbps, or five 9.6 kbps channels using digital time division multiplexing.

(1) Effective June 30, 2021, this Service will no longer be available for purchase by new or existing customers. In addition, requests to move, add, change, or renew existing service arrangements will not be accepted. Following the expiration of a customer's existing term agreement, service will be provided on a month-to-month basis at the applicable Monthly rates until the service is discontinued. The Company currently plans to discontinue this service on or after June 30, 2024.

SPECIAL ACCESS SERVICE

7.1 Service Provisioning (Cont'd)

7.1.1 Types of Service Configurations (Cont'd)

(D) WATS Access Line Service{3}

WATS Access Line Service connects a customer designated premises with the WATS serving office and is provided solely in conjunction with Switched Access Service, Feature Groups D, as set forth in Section 6.

- Except as specified in Footnote {2} WATS Access Lines may not be used for the completion of Local Exchange Service calls. {1}

The following diagram depicts a WATS Access Line Service connecting a customer designated premises to a WATS serving office. The applicable rate elements are:

- Channel Termination (1 applicable)
- Channel Mileage

{1} When an end-user is located in an exchange other than the exchange where the end-user's WATS serving office is located, and the end-user's exchange and the exchange of the WATS serving office have different calling scopes, the blocking of local calls on foreign exchange served WATS access lines will be used on the calling scope of the end-user's exchange rather than the exchange of the WATS serving office. Because of technical problems in certain foreign exchange WATS serving offices, SWBT may not be able to block local calls within the end-user's exchange; therefore, no blocking of local calls in the end-user's exchange will occur.

{2} All calls dialed in the 800 format irrespective of jurisdiction and including local 800 calls are not affected by this restriction.

{3} Effective June 30, 2021, this Service will no longer be available for purchase by new or existing customers. In addition, requests to move, add, change, or renew existing service arrangements will not be accepted. Following the expiration of a customer's existing term agreement, service will be provided on a month-to-month basis at the applicable Monthly rates until the service is discontinued. The Company currently plans to discontinue this service on or after June 30, 2024.

President - Texas
AT&T Texas
Dallas, Texas
Issued: May 9, 2024
Effective: May 10, 2024

ACCESS SERVICE TARIFF
Section: 7
Sheet: 7
Revision: 8
Replacing: 7

SPECIAL ACCESS SERVICE

7.1 Service Provisioning (cont'd)

7.1.2 Types of Channels

For the purpose of ordering, the categories (channel types) of Special Access Service are:

Metallic ⁽¹⁾
Telegraph Grade ⁽¹⁾
Voice Grade ⁽¹⁾

(Deleted)
(Deleted)
Digital Link Service ⁽¹⁾
High Capacity

Detailed descriptions of each of the channel types are provided in 7.3 (Service Descriptions, Rates and Charges).

(1) Effective June 30, 2021, this Service will no longer be available for purchase by new or existing customers. In addition, requests to move, add, change, or renew existing service arrangements will not be accepted. Following the expiration of a customer's existing term agreement, service will be provided on a month-to-month basis at the applicable Monthly rates until the service is discontinued. The Company currently plans to discontinue this service on or after June 30, 2024.

SPECIAL ACCESS SERVICE

7.1 Service Provisioning (Cont'd)

7.1.3 Hubs

(A) General

A hub is a SWBT designated serving wire center at which bridging, multiplexing or Network Reconfiguration Service functions are performed.

- The bridging functions performed may be (1) to connect three or more customer designated premises in a multipoint arrangement, or (2) to reterminate Network Reconfiguration Service or Transport Resource Management Service as set forth in Section 18 (Network Management Service).
- The multiplexing functions are to channelize analog or digital facilities to individual services requiring a lower capacity or bandwidth.

Some of the types of multiplexing available include the following:

- from higher to lower bit rate
- from higher to lower bandwidth
- from digital to voice frequency channels.

End to end services may be provided on channels of these facilities to a hub. The transmission performance for the end to end service provided between customer designated premises will be that of the lower capacity or bit rate. For example, when a 1.544 Mbps facility is multiplexed to voice frequency channels, the transmission performance of the channelized services will be Voice Grade{1}, not High Capacity.

Cascading multiplexing occurs when a High Capacity digital channel is de-multiplexed to provide channels with a lesser capacity and one of the lesser capacity channels is further de-multiplexed. For example, a Supergroup facility is de-multiplexed to five Group facilities and then one of the Group facilities is further de-multiplexed to individual Voice Grade{1} channels.

The Network Reconfiguration Service and Transport Resource Management Service offerings allow the customer to reconfigure their Special Access Services.

(B) Types of Hubs

There are two types of bridging hubs and three types of multiplexing hubs. Bridging hubs are either intermediate or terminus. Multiplexing hubs are intermediate, super intermediate or terminus. The definitions for these hubs are as follows:

(1) Intermediate Bridging Hub

An intermediate bridging hub provides for the connection of three or more customer designated premises to form a Special Access multipoint service serving itself and a specified number of subtending wire centers.

{1} Effective June 30, 2021, this Service will no longer be available for purchase by new or existing customers. In addition, requests to move, add, change, or renew existing service arrangements will not be accepted. Following the expiration of a customer's existing term agreement, service will be provided on a month-to-month basis at the applicable Monthly rates until the service is discontinued. The Company currently plans to discontinue this service on or after June 30, 2024.

SPECIAL ACCESS SERVICE

7.1 Service Provisioning (Cont'd)

7.1.3 Hubs (Cont'd)

(B) Types of Hubs (Cont'd)

(2) Terminus Bridging Hub

A terminus bridging hub provides for the connection of three or more customer designated premises to form a Special Access multipoint service within that bridging hub. For the purpose of multipoint service, the only instance when a terminus bridging hub may be connected to another office will be to interconnect to another bridging office when a bridging function is being performed.

(3) Intermediate Multiplexing Hub

An intermediate multiplexing hub converts from higher to lower bit rate, or bandwidth, or from digital to voice grade{1} channels, serving itself and a specified number of subtending wire centers.

(4) Super Intermediate Multiplexing Hub

A super intermediate multiplexing hub converts from higher to lower bit rate, or bandwidth, or from digital to voice grade{1} channels, serving itself and/or subtending wire centers in an entire LATA, or one or more Numbering Plan Areas (NPAs).

(5) Terminus Multiplexing Hub

A terminus multiplexing hub converts from higher to lower bit rate, or bandwidth, or from digital to voice grade{1} channels, serving customers in that wire center only.

{1} Effective June 30, 2021, this Service will no longer be available for purchase by new or existing customers. In addition, requests to move, add, change, or renew existing service arrangements will not be accepted. Following the expiration of a customer's existing term agreement, service will be provided on a month-to-month basis at the applicable Monthly rates until the service is discontinued. The Company currently plans to discontinue this service on or after June 30, 2024.

SPECIAL ACCESS SERVICE

7.1 Service Provisioning (Cont'd)

7.1.4 Ordering Options and Provisions

Each channel type is identified as a type of Special Access Service. However, such identification is not intended to limit a customer's use of the channel nor to imply that the channel is limited to a particular use. For example, if a customer's equipment is capable of transmitting voice over a channel that is identified as a Metallic Service⁽¹⁾ in this tariff, there is no restriction against doing so.

Customers can order a basic channel and select from a list of available transmission parameters and channel interfaces to meet specific communications requirements.

Additionally, the customer may specify optional features for the individual channels derived from the facility to further tailor the channels to meet specific communications requirements. Descriptions of the optional features and functions available are set forth in 7.3 (Service Descriptions, Rates and Charges).

The customer has the option of ordering Voice Grade⁽¹⁾ and High Capacity (analog or digital) facilities (i.e., Group, Supergroup, Mastergroup, DS1 and DS3) to a SWBT facility hub for multiplexing to individual channels of lower capacity or bandwidth (i.e., Telegraph⁽¹⁾, Voice⁽¹⁾, etc.). Descriptions of the types of multiplexing available at the hubs, as well as the number of individual channels which may be derived from each type of facility are set forth in 7.3 (Service Descriptions, Rates and Charges).

For example, a customer may order a 1.544 Mbps facility from a customer designated premises to a SWBT hub for multiplexing to Voice Grade⁽¹⁾, which may be extended to other customer designated premises. Optional features may be added to either the 1.544 Mbps or the Voice Grade⁽¹⁾ channels.

When ordering multipoint service, bridging or multiplexing, the customer will select the designated bridging hub(s) for its serving wire center from the National Exchange Carrier Association, Inc. Tariff F.C.C. No. 4 and will select the appropriate subtending wire centers from the Subtending Wire Center Section of F.C.C. No. 4. Different locations may be designated as hubs for different facility capacities, e.g., multiplexing from digital to digital may occur at one location, while multiplexing from digital to analog may occur at a different location.

Special Access Service is ordered under the Access Order provisions set forth in Section 5 (Ordering Options for Switched and Special Access Services). Also included in that section are other charges which may be associated with ordering Special Access Service (e.g., Service Date Change Charges, Cancellation Charges, etc.). Ordering provisions as set forth in 2.6 (Jointly Provided Access Service) will apply when more than one local exchange company (LEC) is involved.

(1) Effective June 30, 2021, this Service will no longer be available for purchase by new or existing customers. In addition, requests to move, add, change, or renew existing service arrangements will not be accepted. Following the expiration of a customer's existing term agreement, service will be provided on a month-to-month basis at the applicable Monthly rates until the service is discontinued. The Company currently plans to discontinue this service on or after June 30, 2024.

President - Texas
AT&T Texas
Dallas, Texas
Issued: May 9, 2024
Effective: May 10, 2024

ACCESS SERVICE TARIFF
Section: 7
Sheet: 11
Revision: 1
Replacing: Original

SPECIAL ACCESS SERVICE

7.1 Service Provisioning (Cont'd)

7.1.5 Alternate Use

Alternate Use occurs when a service is arranged by SWBT so that the customer can select different types of transmission at different times. A customer may use a service in any privately beneficial manner. However, where technical or engineering changes are required to effectuate an alternate use, SWBT will make such special arrangements available on an individual case basis as set forth in Section 12 (Specialized Service or Arrangements).

President - Texas
AT&T Texas
Dallas, Texas
Issued: May 9, 2024
Effective: May 10, 2024

ACCESS SERVICE TARIFF
Section: 7
Sheet: 12
Revision: 1
Replacing: Original

SPECIAL ACCESS SERVICE

7.1 Service Provisioning (Cont'd)

7.1.6 Special Facilities Routing

A customer may request that the facilities used to provide Special Access Service be specially routed. The regulations, rates and charges for Special Facilities Routing (i.e., Avoidance, Diversity and Cable-Only) are set forth in Section 11 (Special Facilities Routing of Access Services).

SPECIAL ACCESS SERVICE

7.1 Service Provisioning (cont'd)

7.1.7 Acceptance Testing

Testing and test results are available at the customer's request as follows:

- A.** At no additional charge, SWBT will cooperatively test the following parameters at the time of installation:
 - 1.** For Voice Grade⁽¹⁾ analog service (including WATS Access Lines⁽¹⁾, acceptance tests will include tests for loss, 3-tone slope, DC continuity, operational signaling, C-notched noise, and C-message noise when these parameters are applicable and specified in the order for service. Additionally, for Voice Grade⁽¹⁾ services, a balance test will be made if the customer has ordered the improved loss optional feature.
 - 2.** For other analog services (i.e., Metallic⁽¹⁾ and Telegraph⁽¹⁾, acceptance tests will include tests for the parameters applicable to the service as specified by the customer in the order for service.
 - 3.** For digital services, acceptance tests will include tests applicable to the service as specified in the appropriate Technical References for Digital Link⁽¹⁾ and High Capacity services.
- B.** In addition to the above tests, Additional Cooperative Acceptance Testing for Voice Grade⁽¹⁾ and Digital services to test other parameters, as described in 13.3.7(A) (Additional Cooperative Acceptance Testing), is available.

⁽¹⁾ Effective June 30, 2021, this Service will no longer be available for purchase by new or existing customers. In addition, requests to move, add, change, or renew existing service arrangements will not be accepted. Following the expiration of a customer's existing term agreement, service will be provided on a month-to-month basis at the applicable Monthly rates until the service is discontinued. The Company currently plans to discontinue this service on or after June 30, 2024.

President - Texas
AT&T Texas
Dallas, Texas
Issued: May 9, 2024
Effective: May 10, 2024

ACCESS SERVICE TARIFF
Section: 7
Sheet: 14
Revision: 1
Replacing: Original

SPECIAL ACCESS SERVICE

7.1 Service Provisioning (Cont'd)

7.1.8 Design Layout Report

At the request of the customer, SWBT will provide the make-up of the facilities and services provided under this tariff as Special Access Service to aid the customer in designing its overall service. This information will be provided in the form of a Design Layout Report. The Design Layout Report will be provided to the customer at no charge, and will be reissued or updated whenever the facilities are materially changed.

President - Texas
AT&T Texas
Dallas, Texas
Issued: May 9, 2024
Effective: May 10, 2024

ACCESS SERVICE TARIFF
Section: 7
Sheet: 15
Revision: 2
Replacing: 1

SPECIAL ACCESS SERVICE

7.2 Rate Regulations

This section contains the specific regulations governing the rates and charges that are applicable to Special Access Service. Changes to rates, including rate stability plans, may occur as a result of Public Utility Commission action.

Jurisdictional proration of rates and charges is set forth in 2.4 (Jurisdictional Reports). Where Access Services are jointly-provided, additional regulations are set forth in 2.6 (Jointly Provided Access Service).

SPECIAL ACCESS SERVICE

7.2 Rate Regulations (Cont'd)

7.2.1 Rate Elements

There are three basic rate elements which apply to Special Access Service:

(A) Channel Termination

The Channel Termination rate element provides for the communications path between a customer designated premises and the serving wire center of that premises, or for the communications path within a building which connects a customer's facilities with a customer designated premises without routing through the serving wire center.

Included as part of the Channel Termination is a standard channel interface arrangement which defines the technical characteristics associated with the type of facilities to which the access service is to be connected at the Point of Termination (POT) and the type of signaling capability, if any. The signaling capability itself is provided as an optional feature as set forth in (C) following.

One Channel Termination charge applies per customer designated premises at which the channel is terminated. This charge will apply even if the customer designated premises and the serving wire center are collocated in a SWBT building.

(B) Channel Mileage

The Channel Mileage rate element provides for the transmission facilities between the serving wire centers associated with two customer designated premises, between a serving wire center associated with a customer designated premises and a SWBT hub, between two SWBT hubs, or between a serving wire center associated with a customer designated premises and a WATS serving office.

A flat rate and a rate per mile applies to Channel Mileage.

(C) Optional Features and Functions

The various Optional Features and Functions rate elements provide for optional features and functions which may be added to a Special Access Service to improve its quality or utility to meet specific communications requirements. These are not necessarily identifiable with specific equipment, but rather represent the end result in terms of performance characteristics. Although the equipment necessary to perform a specified function may be installed at various locations along the path of service, it will be charged for as a single rate element.

Examples of Optional Features and Functions that are available include, but are not limited to, the following:

- Signaling Capability
- Hubbing Functions
- Conditioning
- Transfer Arrangements

(D) (Reserved for Future Use)

SPECIAL ACCESS SERVICE

7.2 Rate Regulations (Cont'd)

7.2.1 Rate Elements (Cont'd)

(E) Availability and Allowance for Interruptions on 1.544 Mbps Access Service

Availability is a measure of the relative amount of time that a service is "usable" to the customer. For the purposes of 1.544 Mbps Access Service, service is considered unavailable when 10 consecutive Severely Errored Seconds (SEs) are received. The service becomes available again when no SEs are received for ten consecutive seconds.

The availability objective for 1.544 Mbps Access Service is 99.975% availability when averaged over 3 months.

SWBT, in order to ensure the highest performance standards and service availability to the customer, offers the following service guarantee.

If a 1.544 Mbps Access Service fails due to SWBT provided equipment or facilities and the service is not restored to the customer within 4 hours of the outage report and the service is made available to SWBT by the customer during those 4 hours, the customer will be credited for the full month of service on the following month's bill. This guarantee is subject to the following conditions:

- (1) The monthly credit will be applied on a per circuit, per occurrence, basis and will only be applied once during a month's period. Credits are not accumulative.
- (2) The trouble cause must be isolated to SWBT provided equipment. Trouble determined to be caused by customer provided equipment, or trouble that clears without a positive determination as to cause, will not qualify for the service credit.
- (3) The outage must be reported by the customer. SWBT initiated reports will not qualify for a service credit.
- (4) There may be occasions when the service does not meet the required operating parameters, but due to business conditions the customer will not release the circuit for immediate testing. The service must be made available to SWBT for testing and maintenance. The 4 hour clock does not begin until the outage is reported by the customer and the service is made available by the customer to SWBT for repair.
- (5) On 1.544 Mbps Access Service that uses central office multiplexing provided by SWBT, the service credit applies only to the 1.544 Mbps Access Service portion of the service, and will not apply to the derived channels, nor to multiplexing using the 1.544 Mbps Access Service.
- (6) The service guarantee applies to recurring rates and charges for 1.544 Mbps channel terminations and 1.544 Mbps channel mileage.

President - Texas
AT&T Texas
Dallas, Texas
Issued: May 9, 2024
Effective: May 10, 2024

ACCESS SERVICE TARIFF
Section: 7
Sheet: 18
Revision: 1
Replacing: Original

SPECIAL ACCESS SERVICE

7.2 Rate Regulations (Cont'd)

7.2.2 Monthly Rates

Monthly rates are flat recurring rates that apply each month or fraction thereof that a Special Access Service is provided. For billing purposes, each month is considered to have 30 days.

President - Texas
AT&T Texas
Dallas, Texas
Issued: May 9, 2024
Effective: May 10, 2024

ACCESS SERVICE TARIFF
Section: 7
Sheet: 19
Revision: 1
Replacing: Original

SPECIAL ACCESS SERVICE

7.2 Rate Regulations (Cont'd)

7.2.3 (Reserved for Future Use)

SPECIAL ACCESS SERVICE

7.2 Rate Regulations (Cont'd)

7.2.4 Nonrecurring Charges

Nonrecurring charges are one-time charges that apply for specific work activity (i.e., installation or change to an existing service). The types of nonrecurring charges that apply for Special Access Service are:

- Installation of Service
- Installation of Optional Features and Functions
- Service Rearrangements.

(A) Installation of Service

Nonrecurring charges apply to each service installed. These charges are set forth in 7.3 (Service Descriptions, Rates and Charges) as a nonrecurring charge for the Channel Termination rate element.

(B) Installation of Optional Features and Functions

Nonrecurring charges apply for the installation of some of the optional features and functions available with Special Access Service. The charge applies whether the feature or function is installed coincident with the initial installation of service or at any time subsequent to the installation of the service.

The optional features for which nonrecurring charges apply are:

- Voice Grade Data Capability ⁽¹⁾

- Digital Link Secondary Channel⁽¹⁾
- High Capacity Clear Channel Capability

(C) (Reserved for Future Use)

(D) Service Rearrangements

Service Rearrangements are changes to existing (installed) services which do not result in either (1) a change in the minimum period requirements as set forth in 5.3.4 (Minimum Period Charges) or (2) a change in the physical location of the Point of Termination at a customer designated premises.

Changes which result in the establishment of new minimum period obligations are treated as disconnects and starts. Changes in the physical location of the Point of Termination are treated as moves and are described and charged for as set forth in 7.2.7 (Moves).

The charge to the customer for the service rearrangement is dependent on whether the change is administrative only in nature or involves actual physical change to the service.

⁽¹⁾ Effective June 30, 2021, this Service will no longer be available for purchase by new or existing customers. In addition, requests to move, add, change, or renew existing service arrangements will not be accepted. Following the expiration of a customer's existing term agreement, service will be provided on a month-to-month basis at the applicable Monthly rates until the service is discontinued. The Company currently plans to discontinue this service on or after June 30, 2024.

SPECIAL ACCESS SERVICE

7.2 Rate Regulations (Cont'd)

7.2.4 Nonrecurring Charges (Cont'd)

(D) Service Rearrangements (Cont'd)

- (1) Certain administrative changes will be made without charge to the customer. These administrative changes are as follows:
 - Change of customer name, (i.e., the customer of record does not change but rather the customer of record changes its name--e.g., ABC Communications to All Business Concepts Communications).
 - Change of customer's or customer's end user premises address when the change of address is not a result of a physical relocation of the service.
 - Change in billing data (name, address, contact name, or telephone number).
 - Change of agency authorization.
 - Change of customer test line number.
 - Change of customer's or customer's end user contact name or contact telephone number.
 - Change of jurisdiction.
- (2) When a customer requests a change in the customer of record (i.e., existing access service is provided and billed to a different entity), a nonrecurring charge will apply. This change is considered an administrative service rearrangement when the new customer assumes liability for all current and prior charges for the services(s) and has complied with the regulations and conditions as set forth in 2.2.1 (Assignment and Transfer of Facilities), and no physical relocation or rearrangement of the service is required.
- (3) When a customer requests the following administrative changes, a nonrecurring charge will apply as set forth in 7.4(E) (Service Rearrangement Charge). Each leg of a multipoint service will be treated as a separate circuit and nonrecurring charges will apply per leg on a first and additional basis. If a change(s) for more than one multipoint service is requested on the same Access Order, one first nonrecurring charge will apply to a leg of the first multipoint service. One additional nonrecurring charge will apply to each of the remaining legs of all multipoint services on the same Access Order. The customer requesting administrative service rearrangements will be responsible for all billing associated with the changes requested.
 - Change of Access Carrier Name Abbreviation (ACNA).
 - Change of Customer Carrier Name Abbreviation (CCNA).
 - Change of Billing Account Number (BAN) (e.g., a customer requests to aggregate all voice grade{1} circuits on one BAN).
 - Change of customer Circuit Identification (CKR).

{1} Effective June 30, 2021, this Service will no longer be available for purchase by new or existing customers. In addition, requests to move, add, change, or renew existing service arrangements will not be accepted. Following the expiration of a customer's existing term agreement, service will be provided on a month-to-month basis at the applicable Monthly rates until the service is discontinued. The Company currently plans to discontinue this service on or after June 30, 2024.

SPECIAL ACCESS SERVICE

7.2 Rate Regulations (Cont'd)

7.2.4 Nonrecurring Charges (Cont'd)

(D) Service Rearrangements (Cont'd)

(4) (Reserved for Future Use)

- (5) If the change involves the addition of other customer designated premises to an existing multipoint service, the nonrecurring charge for the Channel Termination rate element will apply. The charge(s) will apply only for the location(s) that is being added.
- (6) If the change involves the addition of an optional feature or function which has a separate nonrecurring charge, that nonrecurring charge will apply.
- (7) If the change involves changing the type of signaling on a Voice Grade{1} service, a charge equal to the Voice Grade{1} channel termination rate element nonrecurring charge will apply. The charge will apply per service termination affected.
- (8) For all other changes, including the addition of an optional feature or function without a separate nonrecurring charge, or the retermination of Special Access circuits in a Network Reconfiguration Service hub or Transport Resource Management Service hub, a charge equal to a channel termination rate element nonrecurring charge will apply. Only one such charge will apply per service, per change.

{1} Effective June 30, 2021, this Service will no longer be available for purchase by new or existing customers. In addition, requests to move, add, change, or renew existing service arrangements will not be accepted. Following the expiration of a customer's existing term agreement, service will be provided on a month-to-month basis at the applicable Monthly rates until the service is discontinued. The Company currently plans to discontinue this service on or after June 30, 2024.

SPECIAL ACCESS SERVICE

7.2 Rate Regulations (Cont'd)

7.2.5 Surcharge for Special Access Service

(A) General Description

The Special Access Surcharge applies to all jurisdictionally intrastate special access facilities ordered from the Special Access section of the Access Service Tariff unless exempted as specified in (B) following.

All such facilities terminated at an end user's PBX or other device that connect the special access facility with local exchange lines or trunks, irrespective of whether the interconnection capability exists in the customer's premises equipment or in a Centrex CO type switch are subject to the surcharge.

(B) Exemption Certification

- (1) The special access facility will be exempted from the monthly surcharge if the customer provides SWBT written certification or an Access Service Request (ASR) indicating that the intrastate special access facility termination is one of the following:
 - (a) An open-end termination in a SWBT switch of an FX line, including CCSA and CCSA-equivalent ONALs; or
 - (b) An analog channel termination that is used for full-time radio or television program transmission; or
 - (c) A termination used for TELEX service; or
 - (d) A termination that by the nature of its operating characteristics could not make use of SWBT common lines; or
 - (e) A termination that interconnects either directly or indirectly to the local exchange network where the usage is subject to Carrier Common Line charges such as, where the special access facility accesses only
 - FGA and no local exchange lines, or
 - special access facility between customer points of termination, or
 - special access facility connecting CCSA or CCSA-type equipment (inter-machine trunks); or
 - (f) A termination that the customer certifies to SWBT is not connected to a PBX or other device capable of interconnecting the special access facility to a local exchange subscriber line, or the PBX or other device has been rendered incapable of interconnection by software or hardware changes.

SPECIAL ACCESS SERVICE

7.2 Rate Regulations (Cont'd)

7.2.5 Surcharge for Special Access Service (Cont'd)

(B) Exemption Certification (Cont'd)

- (2) Exemption certification shall be in the form of an ASR or written notification to SWBT. Such notification shall be provided by the customer (1) when ordered or installed, or (2) at such time as the facility is reterminated to a device not capable of interconnecting to the local exchange network, or (3) at such time as the special access facility becomes associated with a Switched Access Service that is subject to Carrier Common Line charges.

If certification is not received at the time the special access facility is obtained, the surcharge will be applied. Exempt status will become effective on the certification date indicated by the customer, subject to the regulations following.

The exemption certification is to be provided by the customer ordering the service. If written, the certification must be signed by the customer or authorized representative. The ASR or written certification must include the category of exemption, as set forth in (B) preceding, for each termination, and the date which the exemption is effective.

The customer shall also notify SWBT when an exempted Special Access Service is changed or reterminated such that the exemption is no longer applicable.

(C) Surcharge Credits

SWBT will cease billing the Special Access Surcharge when certification that the special access facility has become exempt from the surcharge, as set forth in (B) preceding, is received. If the status of the special access facility was changed prior to receipt of the exemption certification, SWBT will credit the customer's account, not to exceed ninety (90) days, based on the effective date of the change specified by the customer in the letter of certification.

(D) Surcharge Billing

The monthly Special Access Surcharge applies to special access facilities arranged, as set forth in (A) preceding, on a per voice grade channel equivalent basis as shown in the following example.

<u>Private Line Facility</u>	<u>Voice Grade Equivalent</u>		<u>Surcharge</u>		<u>Monthly Charge</u>
Group	12	x	\$ 25	=	\$300.00
DS1	24	x	25	=	600.00

In the case of multipoint special access facilities, one Special Access Surcharge will apply for each termination of a special access channel at an end user's premises.

SWBT will bill the surcharge to the customer who orders the special access facility unless the facility is exempt as set forth in (B) preceding.

President - Texas
AT&T Texas
Dallas, Texas
Issued: May 9, 2024
Effective: May 10, 2024

ACCESS SERVICE TARIFF
Section: 7
Sheet: 25
Revision: 2
Replacing: 1

SPECIAL ACCESS SERVICE

7.2 Rate Regulations (Cont'd)

7.2.6 Mileage Measurement

The mileage to be used to determine the monthly rate for the Channel Mileage is calculated on the airline distance between the locations involved, i.e., the serving wire centers associated with two customer designated premises, a serving wire center associated with a customer designated premises and a SWBT hub, two SWBT hubs or a serving wire center associated with a customer designated premises and the WATS serving office. The serving wire center associated with a customer designated premises is the serving wire center from which the customer designated premises would normally obtain dial tone.

To determine the rate to be billed, first compute the mileage using the V&H coordinates method, as set forth in the National Exchange Carrier Association, Inc. Tariff F.C.C. No. 4, then find the band into which the computed mileage falls and apply the rate shown in 7.3 (Service Descriptions, Rates and Charges) for that band. When the calculation results in a fraction of a mile, always round up to the next whole mile before determining the mileage and applying the rates.

When hubs are involved, mileage is computed and rates applied separately for each section of the Channel Mileage, i.e., customer designated premises serving wire center to hub, hub to hub and/or hub to customer designated premises serving wire center. However, when any service is routed through a hub for purposes other than customer specified bridging, multiplexing, Network Reconfiguration Service or Transport Resource Management Service (e.g., SWBT chooses to so route for test access purposes), rates will be applied only to the distance calculated between the serving wire centers associated with the customer designated premises.

SPECIAL ACCESS SERVICE

7.2 Rate Regulations (cont'd)

7.2.7 Moves

A move involves a change in the physical location of one of the following:

- The Point of Termination at the customer's premises
- The customer's premises

The charges are dependent on the type of move requested by the customer.

A. Moves of the Point of Termination Within the Same Customer Premises

1. Rollover

A Rollover is a customer initiated move that involves a change of a Point of Termination from an existing service to another existing service within the same customer premises. The Rollover must occur within the same SWBT location.

Rollovers may be performed at the following service levels:

- Analog*/Digital Link⁽¹⁾ Service to 1.544 Mbps High Capacity (DS1)
- 1.544 Mbps High Capacity (DS1) to 1.544 Mbps High Capacity (DS1)
- 1.544 Mbps High Capacity (DS1) to 44.736 Mbps High Capacity (DS3)

2. Relocation

When the move of the Point of Termination is to a new location within the same customer premises, the move will be treated as an extension of access service facilities. Extension of access service facilities will be provided, at the customer's request, on a time sensitive charge basis. The labor rates which apply are set forth in 13.4 (Rates and Charges). There will be no change in minimum period requirements.

B. Moves of a Customer Premises

Moves to a different customer premises will be treated as a discontinuance and start of service and all associated nonrecurring charges will apply. New minimum period requirements will be established for the new service. The customer will also remain responsible for satisfying all outstanding minimum period charges for the discontinued service.

- * Analog services include: Metallic Service⁽¹⁾, Telegraph Grade Service⁽¹⁾ or Voice Grade Service⁽¹⁾.

(1) Effective June 30, 2021, this Service will no longer be available for purchase by new or existing customers. In addition, requests to move, add, change, or renew existing service arrangements will not be accepted. Following the expiration of a customer's existing term agreement, service will be provided on a month-to-month basis at the applicable Monthly rates until the service is discontinued. The Company currently plans to discontinue this service on or after June 30, 2024.

President - Texas
AT&T Texas
Dallas, Texas
Issued: May 9, 2024
Effective: May 10, 2024

ACCESS SERVICE TARIFF
Section: 7
Sheet: 26.1
Revision: 1
Replacing: Original

SPECIAL ACCESS SERVICE

7.2 Rate Regulations (Cont'd)

7.2.7 Moves (Cont'd)

(C) Nonrecurring Charges Do Not Apply

Nonrecurring charges do not apply as follows:

- (1) Service reestablished, within the same exchange, after the destruction or partial destruction of the customer's premises by means beyond the control of the customer whether at the same or another location. However, if service is established at a new location and the customer later moves back to the old location, Nonrecurring Charges are applied in connection with the reestablishment of service at the old location. {1}

{1} For customers displaced by the major floods of October, 1994, Nonrecurring Charges do not apply to the establishment of service at an interim location nor to the later reestablishment of service at the same or different location. This provision expires January 31, 1995.

President - Texas
AT&T Texas
Dallas, Texas
Issued: May 9, 2024
Effective: May 10, 2024

ACCESS SERVICE TARIFF
Section: 7
Sheet: 27
Revision: 3
Replacing: 2

SPECIAL ACCESS SERVICE

7.2 Rate Regulations (cont'd)

7.2.8 Minimum Periods

The minimum service period for all services is one month.

SPECIAL ACCESS SERVICE

7.2 Rate Regulations (Cont'd)

7.2.9 Facility Hubs

SWBT will commence billing the monthly rate for the facility to the hub on the date specified by the customer on the Access Order. Individual services using these facilities may be installed coincident with the installation of the facility to the hub or may be ordered and/or installed at a later date, at the option of the customer. The customer will be billed for a Voice Grade⁽¹⁾ or High Capacity digital Channel Termination, Channel Mileage (when applicable), and the Multiplexer at the time the facility is installed. Individual service rates (by service type) will apply for a Channel Termination, additional Channel Mileage (as required) and an Inside Wire Recovery charge, if applicable for each channelized service. These will be billed to the customer as each individual service is installed. The billing must be to the same customer for both parts of the service arrangement.

When cascading multiplexing is performed, whether in the same or a different hub, a charge for the additional multiplexing unit also applies. When cascading multiplexing is performed at different hubbing locations, Channel Mileage charges also apply between the hubs.

The customer will be charged for each such connection made at the rates for Other Labor as set forth in Section 13.2.6(D) (Special Access Move Charges). The rates that apply for the service between each customer designated premises and the hub are a Channel Termination and Channel Mileage, if applicable.

(1) Effective June 30, 2021, this Service will no longer be available for purchase by new or existing customers. In addition, requests to move, add, change, or renew existing service arrangements will not be accepted. Following the expiration of a customer's existing term agreement, service will be provided on a month-to-month basis at the applicable Monthly rates until the service is discontinued. The Company currently plans to discontinue this service on or after June 30, 2024.

SPECIAL ACCESS SERVICE

7.2 Rate Regulations (Cont'd)

7.2.10 Shared Use Analog and Digital High Capacity Services

Shared use occurs when Special Access Service and Switched Access Service are provided over the same High Capacity facilities through a common interface. The facility will be ordered, provided and rated as Special Access Service (i.e., Channel Termination, Channel Mileage, as appropriate, and Multiplexer). The nonrecurring charge that applies when the shared use facility is installed will be the nonrecurring charge associated with the appropriate High Capacity Channel Termination. Rating as Special Access will continue until such time as a portion of the available capacity for providing Special Access Service is used to provide Switched Access Service; in these cases the customer for the Special Access and the Switched Access Service may be different. When the Special Access customer is not the same as the Switched Access Customer, all Special Access charges and Switched Transport charges (including Switched Transport features charges) will be billed to the customer who initially ordered the Special Access Service. All other Switched Access charges will be separately billed to the customer who initially ordered the Switched Access Service. As each individual channel is activated for Switched Access Service, the Special Access Channel Termination, Channel Mileage and Multiplexer rates will be reduced accordingly (e.g., 1/12th for a Group level service, 1/24th for a DS1 service, etc.) except where that channel is utilized in conjunction with CCS/SS7 Interconnection Service. The customer must place an order for each individual Switched or Special Access Service using the shared use facilities and specify the channel assignment for each service.

Switched Access Service rates and charges as set forth in 6.9 (Rates and Charges) will apply for each channel of the shared use facility that is used to provide Switched Access Service. Where Special Access Service is provided using a channel of the shared use facility to the hub, High Capacity rates will apply for the facility to the hub as set forth preceding and individual service rates will apply from the hub to the customer designated premises. The rates that will apply to the portion from the hub to the customer designated premises will be dependent on the specific type of Special Access Service that is provided (e.g., Voice Grade{1}, Telegraph{1}, etc.). The applicable rates will include a Channel Termination rate, Channel Mileage rates, if applicable and an Inside Wire Recovery Charge, if applicable. Rates for optional features and functions, if any, associated with the service will apply as set forth in 7.3 (Service Descriptions, Rates and Charges).

{1} Effective June 30, 2021, this Service will no longer be available for purchase by new or existing customers. In addition, requests to move, add, change, or renew existing service arrangements will not be accepted. Following the expiration of a customer's existing term agreement, service will be provided on a month-to-month basis at the applicable Monthly rates until the service is discontinued. The Company currently plans to discontinue this service on or after June 30, 2024.

President - Texas
AT&T Texas
Dallas, Texas
Issued: May 9, 2024
Effective: May 10, 2024

ACCESS SERVICE TARIFF
Section: 7
Sheet: 30
Revision: 2
Replacing: 1

SPECIAL ACCESS SERVICE

7.2 Rate Regulations (Cont'd)

7.2.11 WATS Access Lines{1}

When WATS Access Lines (WAL) are provided, the rate elements which apply are:

- WATS Access Line Termination
- Optional Features and Functions (when applicable)

The WATS Access Line Termination charge includes channel facilities from the customer premises to the serving wire center and where applicable, also include channel facilities from the serving wire center to the WATS serving office.

When extensions (i.e., additional terminations of the service at a different premises in the same or a different LATA) are provided, they are rated in the following manner. Both interLATA and intraLATA extensions require an additional WAL Channel Termination and Channel Mileage (as needed).

{1} Effective June 30, 2021, this Service will no longer be available for purchase by new or existing customers. In addition, requests to move, add, change, or renew existing service arrangements will not be accepted. Following the expiration of a customer's existing term agreement, service will be provided on a month-to-month basis at the applicable Monthly rates until the service is discontinued. The Company currently plans to discontinue this service on or after June 30, 2024.

SPECIAL ACCESS SERVICE

7.2 Rate Regulations (Cont'd)

7.2.12 Two-Point Service

The rate elements applicable to a two-point service are:

- Channel Terminations
- Channel Mileage (as applicable)
- Optional Features and Functions (when applicable)

In addition, a Special Access Surcharge, as set forth in 7.2.5 and a Message Station Equipment Recovery Charge, as set forth in 7.2.17 may be applicable.

The following diagram depicts a two-point Voice Grade{1} service, provided with C-Conditioning, connecting two customer designated premises located 15 miles apart. The applicable rate elements are:

- Channel Termination (2 applicable)
- Channel Mileage (mileage band over 8 to 25 miles)
- C-Conditioning Optional Feature (1 per Channel Termination)

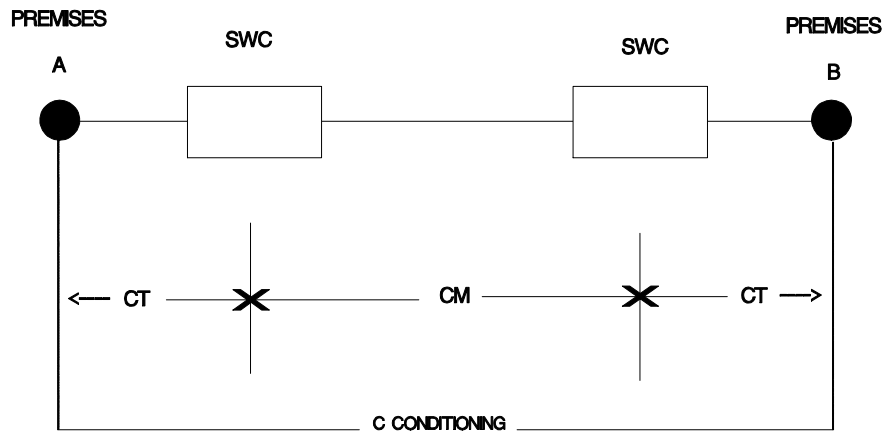

{1} Effective June 30, 2021, this Service will no longer be available for purchase by new or existing customers. In addition, requests to move, add, change, or renew existing service arrangements will not be accepted. Following the expiration of a customer's existing term agreement, service will be provided on a month-to-month basis at the applicable Monthly rates until the service is discontinued. The Company currently plans to discontinue this service on or after June 30, 2024.

SPECIAL ACCESS SERVICE

7.2 Rate Regulations (Cont'd)

7.2.13 Multipoint Service

The rate elements applicable to multipoint service are as follows:

- Channel Terminations (one per customer designated premises)
- Channel Mileage (as applicable)
- Bridging
- Optional Features and Functions (when applicable)

In addition, the Special Access Surcharge, as set forth in 7.2.5, and a Message Station Equipment Recovery Charge, as set forth in 7.2.17 may be applicable.

(A) Following is an example of a multipoint service in which Voice Grade{1} multipoint service connects four customer premises via two customer specified bridging hubs. The applicable rate elements are:

- Channel Termination (4 applicable)
- Channel Mileage (5 sections)
- Bridging Optional Feature (6 applicable, i.e., one at each bridge port)

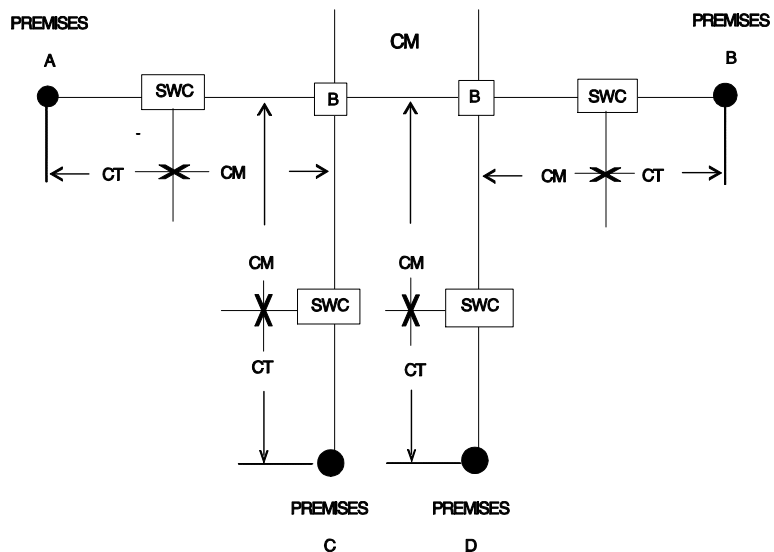

{1} Effective June 30, 2021, this Service will no longer be available for purchase by new or existing customers. In addition, requests to move, add, change, or renew existing service arrangements will not be accepted. Following the expiration of a customer's existing term agreement, service will be provided on a month-to-month basis at the applicable Monthly rates until the service is discontinued. The Company currently plans to discontinue this service on or after June 30, 2024.

SPECIAL ACCESS SERVICE

7.2 Rate Regulations (Cont'd)

7.2.13 Multipoint Service (Cont'd)

(B) An example of a hubbing arrangement, with its applicable rate elements indicated, is shown following:

Voice Grade{1} Multipoint where two offices do not subtend from Intermediate Bridging Hub 1. The two offices subtend from separate Intermediate Hubs.

Office 2A subtends from Intermediate Hub 2. Office 3A subtends from Intermediate Hub 3. However, SWBT will serve offices 2A and 3A from the common bridge in Intermediate Hub 1.

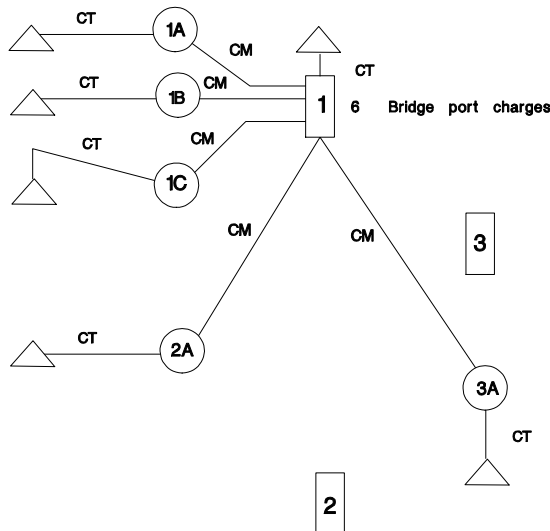

Legend

- △ Customer Premises
- CM = Channel Mileage
- CT = Channel Termination
- ▭ Intermediate Bridging Hub and Serving Wire Center
- Terminus Bridging Hub and Serving Wire Center

{1} Effective June 30, 2021, this Service will no longer be available for purchase by new or existing customers. In addition, requests to move, add, change, or renew existing service arrangements will not be accepted. Following the expiration of a customer's existing term agreement, service will be provided on a month-to-month basis at the applicable Monthly rates until the service is discontinued. The Company currently plans to discontinue this service on or after June 30, 2024.

SPECIAL ACCESS SERVICE

7.2 Rate Regulations (Cont'd)

7.2.14 Multiplexed Service

The rate elements applicable to be multiplexed service are as follows:

- Channel Terminations
- Channel Mileage
- Multiplexing

In addition, the Special Access Surcharge, as set forth in 7.2.5 and a Message Station Equipment Recovery Charge, as set forth in 7.2.17 may be applicable.

Following is an example of multiplexing a 1.544 Mbps channel to 24 Voice Grade{1} channels.

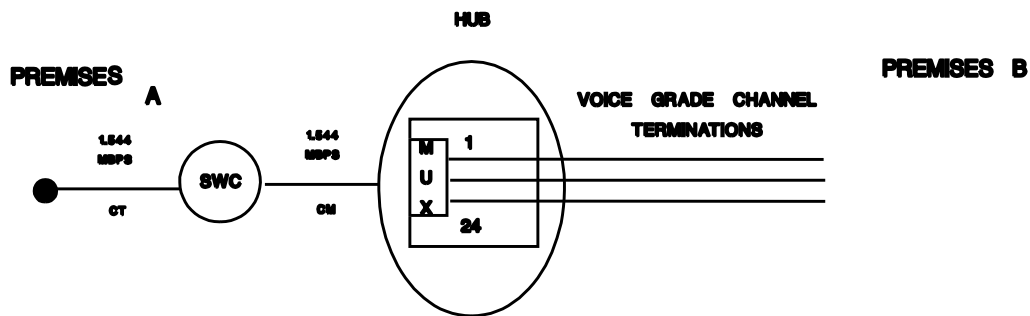

{1} Effective June 30, 2021, this Service will no longer be available for purchase by new or existing customers. In addition, requests to move, add, change, or renew existing service arrangements will not be accepted. Following the expiration of a customer's existing term agreement, service will be provided on a month-to-month basis at the applicable Monthly rates until the service is discontinued. The Company currently plans to discontinue this service on or after June 30, 2024.

President - Texas
AT&T Texas
Dallas, Texas
Issued: May 9, 2024
Effective: May 10, 2024

ACCESS SERVICE TARIFF
Section: 7
Sheet: 35
Revision: 1
Replacing: Original

SPECIAL ACCESS SERVICE

7.2 Rate Regulations (Cont'd)

7.2.15 Alternate Use

The arrangement required to transfer the service from one operation to the other (i.e., the transfer relay and control leads) will be rated and provided on an individual case basis and filed in Section 12 (Specialized Service or Arrangements). In addition, the customer will pay the stated tariff rates for the Access Service rate elements for the service ordered (i.e., Channel Terminations, Channel Mileage and Optional Features and Functions).

President - Texas
AT&T Texas
Dallas, Texas
Issued: May 9, 2024
Effective: May 10, 2024

ACCESS SERVICE TARIFF
Section: 7
Sheet: 36
Revision: 1
Replacing: Original

SPECIAL ACCESS SERVICE

7.2 Rate Regulations (Cont'd)

7.2.16 Customized Channels

When a customized channel is ordered, the customer will be notified whether Additional Engineering Charges apply. In such cases, the customer will be given an estimate of the hours to be billed before any further action is taken on the order.

President - Texas
AT&T Texas
Dallas, Texas
Issued: May 9, 2024
Effective: May 10, 2024

ACCESS SERVICE TARIFF
Section: 7
Sheet: 37
Revision: 1
Replacing: Original

SPECIAL ACCESS SERVICE

7.2 Rate Regulations (Cont'd)

7.2.17 Message Station Equipment Recovery Charge

The Message Station Equipment Recovery Charge is a charge to recover that portion of message station equipment that is assigned to Special Access Service.

This charge is assessed only to those customers to which the Special Access Surcharge applies. The rate for the Message Station Equipment Recovery is set forth in 7.4(C).

President - Texas
AT&T Texas
Dallas, Texas
Issued: May 9, 2024
Effective: May 10, 2024

ACCESS SERVICE TARIFF
Section: 7
Sheet: 38
Revision: 1
Replacing: Original

SPECIAL ACCESS SERVICE

7.2 Rate Regulations (Cont'd)

7.2.18 (Reserved for Future Use)

President - Texas
AT&T Texas
Dallas, Texas
Issued: May 9, 2024
Effective: May 10, 2024

ACCESS SERVICE TARIFF
Section: 7
Sheet: 39
Revision: 1
Replacing: Original

SPECIAL ACCESS SERVICE

7.2 Rate Regulations (Cont'd)

7.2.19 (Reserved for Future Use)

President - Texas
AT&T Texas
Dallas, Texas
Issued: May 9, 2024
Effective: May 10, 2024

ACCESS SERVICE TARIFF
Section: 7
Sheet: 40
Revision: 2
Replacing: 1

SPECIAL ACCESS SERVICE

7.2 Rate Regulations (Cont'd)

7.2.20

President - Texas
AT&T Texas
Dallas, Texas
Issued: May 9, 2024
Effective: May 10, 2024

ACCESS SERVICE TARIFF
Section: 7
Sheet: 40.1
Revision: 2
Replacing: 1

SPECIAL ACCESS SERVICE

7.2 Rate Regulations (cont'd)

7.2.21 Reserved for future use

President - Texas
AT&T Texas
Dallas, Texas
Issued: May 9, 2024
Effective: May 10, 2024

ACCESS SERVICE TARIFF
Section: 7
Sheet: 40.2
Revision: 2
Replacing: 1

SPECIAL ACCESS SERVICE

SPECIAL ACCESS SERVICE

7.2 Rate Regulations (Cont'd)

7.2.22 High Capacity Term Pricing Plan (HC-TPP)

(A) General Description

High Capacity Term Pricing Plan (HC-TPP) provides the customer with rate stabilization and discounted tariff rates. The customer agrees to a minimum monthly revenue commitment when establishing service under HC-TPP.

The minimum monthly revenue commitment is established on a per LATA or state level as described in 7.2.22(C)(1)(Minimum Monthly Revenue Commitment). When the minimum monthly revenue commitment is met at the LATA or state level, the customer has the ability to move an HC-TPP circuit within the level specified from one location to another location without incurring a Termination Charge.

Decreases in HC-TPP monthly recurring tariff rates will be passed on to customers who participate in a HC-TPP. The customer's minimum monthly revenue commitment will be reduced accordingly. SWBT will notify customers participating in HC-TPP when monthly rates are decreased.

Should SWBT increase its rates during the HC-TPP period, the customer would continue to pay the rates in effect at the time the customer elected to establish service under HC-TPP.

If the customer upgrades to High Capacity Customer Specific Pricing Plan (CSPP) Service, the minimum monthly revenue commitment will be decreased to reflect the decreased number of circuits.

(B) Services Available Under HC-TPP

A customer may elect to participate in HC-TPP for the following rate elements as described in 7.3 (Service Descriptions, Rates and Charges):

- High Capacity Channel Termination
- High Capacity Channel Mileage (Fixed and Per Mile)
- High Capacity Multiplexing

SPECIAL ACCESS SERVICE

7.2 Rate Regulations (Cont'd)

7.2.22 High Capacity Term Pricing Plan (HC-TPP) (Cont'd)

(C) Terms and Conditions

(1) Minimum Monthly Revenue Commitment

The customer agrees to a minimum monthly revenue commitment when electing to participate in a HC-TPP. The minimum monthly revenue commitment is determined when the customer specifies the quantity of services to be included in the HC-TPP. That amount is then calculated using the current HC-TPP rates in effect at the time to arrive at the minimum monthly revenue commitment.

The minimum monthly revenue commitment is calculated as follows:

$$\begin{array}{r} \text{(Number of circuits)} \\ \text{(ordered)} \end{array} \quad \times \quad \begin{array}{r} \text{(Rates in effect when)} \\ \text{(customer establishes)} \\ \text{(HC-TPP service)} \end{array}$$

= Initial minimum monthly revenue commitment.

The customer may establish the HC-TPP minimum monthly revenue commitment at either a LATA or state level as follows:

Less than 91% of total DS1 revenues is established as
HC-TPP = LATA

91% or greater of total DS1 revenues is established as
HC-TPP = state

(a) Maintaining the Minimum Monthly Revenue Commitment

A customer who chooses the state level must maintain that level of minimum monthly revenue commitment for a minimum of one year.

At the quarterly review, if the level is below 91%, the customer has 30 days to increase the revenue to 91% or greater to maintain the state level.

If the customer elects not to increase the revenues, the minimum monthly revenue commitment will be modified to reflect the LATA level and an Access Order charge will apply.

(b) Exceeding the Minimum Monthly Revenue Commitment

The customer may exceed the minimum monthly revenue commitment by 10 percent throughout the life of a 3 year HC-TPP⁽²⁾ or by 15 percent throughout the life of a 5 year HC-TPP.⁽¹⁾ If the customer exceeds the minimum monthly revenue commitment by more than 10 percent during a consecutive three-month period on a 3 year HC-TPP⁽²⁾, that portion of the minimum monthly revenue commitment will be assessed and billed a 20 percent adjustment factor. If the customer exceeds the minimum monthly revenue commitment by more than 15 percent during a consecutive three-month period on a 5 year HC-TPP,⁽¹⁾ that portion of the minimum monthly revenue commitment will be assessed and billed a 30 percent adjustment factor. The revenue commitment amount will be reconciled quarterly.

(1) Effective on February 16, 2019, High Capacity Term Pricing Plans are no longer available for 5 year term lengths, including for any otherwise available renewals, extensions or conversions.

(2) Effective November 1, 2022, High Capacity Term Pricing Plans for 3-year term lengths are no longer available, including conversions. Existing Term Plan Services, as of November 1, 2022, will continue to be provided under the then-current terms, for the remainder of the applicable term.

SPECIAL ACCESS SERVICE

7.2 Rate Regulations (Cont'd)

7.2.22 High Capacity Term Pricing Plan (HC-TPP) (Cont'd)

(C) Terms and Conditions (Cont'd)

(1) Minimum Monthly Revenue Commitment (Cont'd)

(b) Exceeding the Minimum Monthly Revenue Commitment (Cont'd)

The adjustment factor will be billed until such time as the customer establishes a new revenue commitment or the billing no longer exceeds the 10 or 15 percent allowance.

The adjustment factor will not apply to the state level minimum monthly revenue commitment.

(c) Increasing the Minimum Monthly Revenue Commitment

The customer has the option to increase the minimum monthly revenue commitment rather than pay the adjustment factor. If the increase is received within 30 days of the time the adjustment factor was billed, the adjustment factor will not apply. To initiate an increase in the minimum monthly revenue commitment, the customer must provide the amount of the increase in writing with the understanding that this increase and minimum monthly revenue commitment becomes the new minimum monthly revenue commitment.

The increased minimum monthly commitment would be calculated as follows:

(Rates in effect)	
(when customer	Service to) (Existing minimum)
(established	X be added) + (monthly revenue)
(increased service)		(commitment)
(under HC-TPP)	

= Increased minimum monthly revenue commitment.

An increase in the minimum monthly revenue commitment does not change any of the conditions in effect during the life of the HC-TPP.

Rather than increase the minimum monthly revenue commitment, the customer has the following options available to assist in their control of the HC-TPP:

- Order temporary services under month-to-month tariffed rates rather than include them in the HC-TPP;
- Renegotiate the HC-TPP for a longer term;
- Move those services that caused the excess over the minimum monthly revenue commitment to month-to-month tariffed rates;
- Reconfigure the network using various network consolidation methods;
- Accept the adjustment as a temporary financial obligation; or
- Establish a separate HC-TPP for those services that caused the excess over the minimum monthly revenue commitment.

SPECIAL ACCESS SERVICE

7.2 Rate Regulations (Cont'd)

7.2.22 High Capacity Term Pricing Plan (HC-TPP) (Cont'd)

(C) Terms and Conditions (Cont'd)

(1) Minimum Monthly Revenue Commitment (Cont'd)

(d) Decreasing the Minimum Monthly Revenue Commitment

The customer may elect to decrease the minimum monthly revenue commitment at any time during the life of the HC-TPP. To initiate a decrease in the minimum monthly revenue commitment, the customer must provide the amount of the decrease in writing with the understanding that the decreased minimum monthly revenue commitment becomes the new minimum monthly revenue commitment.

The decreased minimum monthly revenue commitment will be calculated as follows:

$$\begin{array}{r} \text{(Existing minimum)} \quad \text{(Decrease in minimum)} \\ \text{(monthly revenue)} \quad \text{(monthly revenue)} \\ \text{(commitment)} \quad \text{(commitment)} \\ \hline \end{array}$$

= Decreased (new) minimum monthly revenue

In addition, the customer will be assessed a termination charge of 20% on either a 3 year or 5 year HC-TPP⁽¹⁾⁽²⁾ as follows:

$$\begin{array}{r} \text{(Termination)} \quad \text{(Decrease in)} \quad \text{(Months)} \\ \text{(percentage)} \quad \text{(revenue)} \quad \text{(remaining)} \\ \text{(commitment)} \quad \text{(commitment)} \quad \text{(in revenue)} \\ \hline \end{array}$$

= Termination charge.

A decrease in the minimum monthly revenue commitment does not change any of the conditions in effect during the life of the HC-TPP.

(1) Effective on February 16, 2019, High Capacity Term Pricing Plans are no longer available for 5 year term lengths, including for any otherwise available renewals, extensions or conversions.

(2) Effective November 1, 2022, High Capacity Term Pricing Plans for 3-year term lengths are no longer available, including conversions. Existing Term Plan Services, as of November 1, 2022, will continue to be provided under the then-current terms, for the remainder of the applicable term.

SPECIAL ACCESS SERVICE

7.2 Rate Regulations (Cont'd)

7.2.22 High Capacity Term Pricing Plan (HC-TPP) (Cont'd)

(C) Terms and Conditions (Cont'd)

(2) Nonrecurring Charges

The nonrecurring charges under 7.3 (Service Descriptions, Rates and Charges) apply for those services ordered and installed under an HC-TPP. The nonrecurring charges will not apply toward the minimum monthly revenue commitment.

The nonrecurring charges under 7.3 (Service Descriptions, Rates and Charges) do not apply to existing services that are to be billed under HC-TPP; however, the Access Order Charge (AOC) under 5.2 (Access Order) and 5.4(A)(2) (Access Order Charges) will apply.

(3) Renegotiation

The customer may choose to terminate an existing HC-TPP before the end of the three or five year period and negotiate a new three or five year HC-TPP⁽¹⁾⁽²⁾ without termination liability if the HC-TPP meets the following requirements:

- (a) the new HC-TPP must have a greater minimum monthly revenue commitment than the previous HC-TPP, and
- (b) the new HC-TPP must be based upon the rates that are currently in effect and available to all customers.

An existing three year HC-TPP⁽²⁾ may be converted into a five year HC-TPP without termination liabilities,⁽¹⁾ provided that:

- (a) the three year HC-TPP⁽²⁾ has not ended,
- (b) the converted HC-TPP must be based upon the rates that are currently in effect and otherwise available to all customers, and
- (c) the customer's minimum monthly revenue commitment will be adjusted accordingly, based upon the applicable five year HC-TPP rates times the customer's current HC-TPP number of circuits ordered.

When the customer converts to a five year HC-TPP,⁽¹⁾ actual time in service for the original HC-TPP will be applied to the new HC-TPP. However, no credits or refunds will apply for the billing of actual time in service for the previous HC-TPP.

Subject to the conditions and termination liabilities of 7.2.22(D)(3)(a), the customer can also terminate an HC-TPP in the situation of expanded interconnection for special access services.

(1) Effective on February 16, 2019, High Capacity Term Pricing Plans are no longer available for 5 year term lengths, including for any otherwise available renewals, extensions or conversions.

(2) Effective November 1, 2022, High Capacity Term Pricing Plans for 3-year term lengths are no longer available, including conversions. Existing Term Plan Services, as of November 1, 2022, will continue to be provided under the then-current terms, for the remainder of the applicable term.

SPECIAL ACCESS SERVICE

7.2 Rate Regulations (Cont'd)

7.2.22 High Capacity Term Pricing Plan (HC-TPP) (Cont'd)

(C) Terms and Conditions (Cont'd)

(4) Renewal⁽²⁾

The customer must provide SWBT with a written notice of intent to renew or extend an HC-TPP no later than 60 days prior to its expiration. The renewal rates will be the rates that are currently in effect and available to all customers. If the customer elects not to renew or extend the HC-TPP, or does not notify SWBT of his or her intent to renew or extend the HC-TPP, the customer's service will automatically be billed under the tariffed month-to-month rates in effect at the time the HC-TPP expires.

(5) Extension of Service⁽²⁾

The customer may elect to extend the existing HC-TPP for a single, additional 24 month period at the current rates for the three or five year HC-TPP being extended. If the current HC-TPP rates are lower than the original HC-TPP rates, the customer's minimum monthly revenue commitment will be adjusted accordingly. If current HC-TPP rates create a minimum monthly revenue commitment higher than the existing minimum monthly revenue commitment, the customer's existing minimum monthly revenue commitment will continue to apply.

The customer must provide SWBT with a written notice of intent to extend the HC-TPP no later than 60 days prior to the expiration of the service period.

(6) Upgrades of Service

A customer may upgrade HC-TPP service to High Capacity-Customer Specific Pricing Plan (HC-CSPP) service without termination liability given that:

- (a) the customer identifies the TPP services being moved,
- (b) the CSP service that the above TPP services are being moved to is a new CSP service,
- (c) the upgrade rates are individual case basis (ICB) rates developed in accordance with Section 2 (High Capacity Service) of the Customer Specific Pricing Plan Tariff available to all customers, and
- (d) the due date to disconnect the TPP service and the due date to connect the CSP service must be the same.

The AOC will apply.

(7) Conversion from Intrastate to Interstate HC-TPP ^{(1) (3)}

Customers may convert an existing intrastate HC-TPP to a new interstate HC-TPP without termination liability providing the following conditions are met:

- (a) the customer must provide the Telephone Company written notice of intent to convert intrastate circuits to interstate circuits no later than 30 days prior to requested due date.
- (b) the customer identifies the HC-TPP circuits being moved.

⁽¹⁾ This revision is effective as of September 1, 1996 pursuant to PURA Section 3.356 and SWBT's notification thereunder.

⁽²⁾ Effective on February 16, 2019, High Capacity Term Pricing Plans are no longer available for 5 year term lengths, including for any otherwise available renewals, extensions or conversions.

⁽³⁾ Effective on February 16, 2019, interstate High Capacity Term Pricing Plans are no longer available.

SPECIAL ACCESS SERVICE

7.2 Rate Regulations (Cont'd)

7.2.22 High Capacity Term Pricing Plan (HC-TPP) (Cont'd)

(C) Terms and Conditions (Cont'd)

(7) Conversion from Intrastate to Interstate HC-TPP⁽¹⁾ (Cont'd)

- (c) the customer must enter into a new 3 year or 5 year interstate HC-TPP with a new minimum monthly revenue commitment and the new 3 year or 5 year interstate HC-TPP must be greater than the period remaining on the existing intrastate HC-TPP.
- (d) the removal due date of the existing intrastate HC-TPP and the establishment due date of the new interstate HC-TPP must be the same date.
- (e) the new interstate HC-TPP rates will be based upon those rates in effect for interstate HC-TPP at the time of the conversion and will be those rates currently available to all customers.

The AOC will apply.

(D) Rate Applications

(1) Billed Revenues

If the customer reduces the number of circuits under HC-TPP without decreasing the minimum monthly revenue commitment, the initial minimum monthly revenue commitment will be billed.

(2) Special Construction Charges

Any special construction charges incurred for services billed under an HC-TPP will apply. These charges do not apply toward the minimum monthly revenue commitment.

(3) Termination of Service

- (a) If the customer gives notice within 120 days after SWBT files a tariff transmittal that intrastate expanded interconnection for special access service is operational in those customer's central offices, that the customer intends to terminate the HC-TPP contract with SWBT in order to take the service from an interconnector, the customer shall pay the lesser of the following termination charges:

- (1) the additional charges the customer would have paid for the high capacity service if the customer had entered into a shorter term contract or tariffed rate for the term or service actually used, plus interest based on the average of prime commercial paper rates as set by the Commission for the previous twelve month period; or
- (2) the normally applicable termination charges in the HC-TPP contract.

In order to be eligible for the above termination charges, the customer must have entered into the HC-TPP contract on or before the date of the Commission's final adoption of an initial expanded interconnection rule for special access services and the customer must actually terminate services with SWBT within 60 days after expanded interconnection is operational and take service from an interconnector.

⁽¹⁾ Effective on February 16, 2019, interstate High Capacity Term Pricing Plans are no longer available.

SPECIAL ACCESS SERVICE

7.2 Rate Regulations (Cont'd)

7.2.22 High Capacity Term Pricing Plan (HC-TPP) (Cont'd)

(D) Rate Applications (Cont'd)

(3) Termination of Service (Cont'd)

(b) In all other cases, customers requesting the termination of an HC-TPP prior to the expiration date, excluding HC-TPP terminated as a result of a renegotiation and cases described in (a) above, will be charged as indicated following:

<u>HC-TPP</u>	<u>Termination Percentage</u>
3 years ⁽²⁾	20%
5 years ⁽¹⁾	20%

The termination charges will be calculated as follows:

$$\begin{aligned} & \text{(Minimum monthly)} & \text{(Months remaining)} & \text{(Termination)} \\ & \text{(revenue commitment)} \times & \text{(in HC-TPP)} \times & \text{(percentage)} \\ & & & = \text{Termination charge.} \end{aligned}$$

Customers requesting the termination of an HC-TPP prior to the expiration date of an extension of service will be calculated as follows:

$$\begin{aligned} & \text{Number of months} & \text{Current HC-TPP} \\ & \text{utilized of the X} & \text{Monthly} = \text{Monthly} \\ & \text{extension of serviceRate} & \text{Rate} \\ & & = \text{Termination charge.} \end{aligned}$$

(E) (reserve for future use)

(1) Effective on February 16, 2019, High Capacity Term Pricing Plans are no longer available for 5 year term lengths, including for any otherwise available renewals, extensions or conversions.

(2) Effective November 1, 2022, High Capacity Term Pricing Plans for 3-year term lengths are no longer available, including conversions. Existing Term Plan Services, as of November 1, 2022, will continue to be provided under the then-current terms, for the remainder of the applicable term.

SPECIAL ACCESS SERVICE

7.3 Service Descriptions, Rates and Charges

7.3.1 General

The types of Special Access Service are:

Metallic (MT) ⁽¹⁾
Telegraph Grade (TG) ⁽¹⁾
Voice Grade (VG) ⁽¹⁾

Digital Link (DL) ⁽¹⁾
High Capacity (HC)

Each of the channel types has its own characteristics. All are subdivided by one or more of the following:

- Transmission specifications
- Bandwidth
- Speed (i.e., bit rate)
- Spectrum.

A. Descriptions

Each service consists of a basic channel to which the following services can be added as required to construct the service desired by the customer:

- Technical specifications packages (customized or predefined)
- Channel interface(s)
- Optional features and functions.

Paragraph (A) of 7.3.2 through 7.3.11 provides a description of the characteristics of each basic channel type and indicates whether the channel is provided between customer designated premises or between a customer designated premises and a SWBT hub where bridging or multiplexing functions are performed. Customized channels are available as specified in 7.2.16.

(1) Effective June 30, 2021, this Service will no longer be available for purchase by new or existing customers. In addition, requests to move, add, change, or renew existing service arrangements will not be accepted. Following the expiration of a customer's existing term agreement, service will be provided on a month-to-month basis at the applicable Monthly rates until the service is discontinued. The Company currently plans to discontinue this service on or after June 30, 2024.

President - Texas
AT&T Texas
Dallas, Texas
Issued: May 9, 2024
Effective: May 10, 2024

ACCESS SERVICE TARIFF
Section: 7
Sheet: 41.1
Revision: 1
Replacing: Original

SPECIAL ACCESS SERVICE

7.3 Service Descriptions, Rates and Charges (cont'd)

7.3.1 General (cont'd)

B. Technical Specifications Packages

A matrix is provided in paragraph (B) of 7.3.2 through 7.3.10 which indicates the transmission parameters that are available with each Technical Specifications Package. The codes used to design the packages are constructed using the information shown across the top of the matrix as follows:

- The first two symbols of the code are letters which indicate the category of Special Access Service to which the parameters are applicable. These two letter codes also are shown in parentheses following the channel type in 7.3.1 preceding.
- An alpha, numeric or alpha-numeric designation follows these two letters to indicate the specific predefined package.

SPECIAL ACCESS SERVICE

7.3 Service Descriptions, Rates and Charges (cont'd)

7.3.1 General (cont'd)

B. Technical Specifications Packages (cont'd)

- The letter "C" following the two letter code indicates the technical specifications package for a customized service. For a customized service, the customer may select any parameters available with that category of service as long as the parameters are compatible. Customized technical specifications packages will be provided where technically feasible. If SWBT determines that the requested parameter specifications are not compatible, the customer will be advised and given the opportunity to change the order.

SWBT will maintain existing transmission specifications on services installed prior to the effective date of this tariff, except that existing services with performance specifications exceeding the standards listed in this provision will be maintained at the performance levels specified in this tariff.

All services installed after the effective date of this tariff will conform to the transmission specification standards contained in this tariff or in the following Technical References for each category of service.

Metallic ⁽¹⁾	TR-NPL-000336
Telegraph Grade ⁽¹⁾	TR-NPL-000336
Voice Grade ⁽¹⁾	TR-TSY-000335
PUB	41004, Table 4
WALS ⁽¹⁾	TR-NWT-000334
Digital Link ⁽¹⁾	TR-NPL-000341
PUB	62310
High Capacity	PUB 76625
PUB	62411
TR-INS-000342	

Customers who wish to obtain copies of these references may obtain ordering information from the User's Guide section of this tariff.

(1) Effective June 30, 2021, this Service will no longer be available for purchase by new or existing customers. In addition, requests to move, add, change, or renew existing service arrangements will not be accepted. Following the expiration of a customer's existing term agreement, service will be provided on a month-to-month basis at the applicable Monthly rates until the service is discontinued. The Company currently plans to discontinue this service on or after June 30, 2024.

President - Texas
AT&T Texas
Dallas, Texas
Issued: May 9, 2024
Effective: May 10, 2024

ACCESS SERVICE TARIFF
Section: 7
Sheet: 42.1
Revision: 1
Replacing: Original

SPECIAL ACCESS SERVICE

7.3 Service Descriptions, Rates and Charges (cont'd)

7.3.1 General (cont'd)

C. Channel Interfaces

A matrix is provided in paragraph (C) of 7.3.2 through 7.3.10 that indicates the channel interfaces which are compatible with each channel type.

Channel interfaces at each Point of Termination on a two-point or multipoint service may be symmetrical or asymmetrical. However, communications can only be provided between points of termination with compatible channel interfaces. Only certain channel interfaces are compatible. These may be found in the appropriate Technical Reference cited for each channel type.

Only certain channel interface combinations are available with the predefined technical specifications packages. These are delineated in the Technical References cited in (B) preceding. When a customized channel is requested, all channel interface combinations available with the specified type of service are available with the customized channel.

President - Texas
AT&T Texas
Dallas, Texas
Issued: May 9, 2024
Effective: May 10, 2024

ACCESS SERVICE TARIFF
Section: 7
Sheet: 43
Revision: 1
Replacing: Original

SPECIAL ACCESS SERVICE

7.3 Service Descriptions, Rates and Charges (Cont'd)

7.3.1 General (Cont'd)

(D) Optional Features and Functions

Information is included in 7.3.2 through 7.3.10, where appropriate, to provide a description of the optional features and functions available with each type of Special Access Service and to indicate with which technical packages they are available. A description of each optional feature and function is also provided.

SPECIAL ACCESS SERVICE

7.3 Service Descriptions, Rates and Charges (Cont'd)

7.3.2 Metallic Service {1}

(A) Basic Channel Description

A Metallic channel is an unconditioned two-wire channel capable of transmitting low speed varying signals at rates up to 30 baud. This channel is provided by metallic or equivalent facilities. Metallic channels are provided between customer designated premises or between a customer designated premises and a SWBT hub where bridging functions are performed. Interoffice metallic facilities will be limited in length to a total of five miles per channel.

(B) Technical Specifications Packages

Transmission Parameter	Package MT-			
	<u>C</u>	<u>1</u>	<u>2</u>	<u>3</u>
DC Resistance				
Between Conductors	X	X	X	
Loop Resistance	X			X
Shunt Capacitance	X			X

(C) Channel Interfaces (CI)

The following channel interfaces identify the direct current or voltage at the interface.

CI	DC/Voltage
DC-1	Monitoring with series RC combination
DC-2	Energized interface
DC-3	DC Continuity

(D) Optional Features and Functions

	Package MT-			
	<u>C</u>	<u>1</u>	<u>2</u>	<u>3</u>
Central Office Bridging:				
Series Bridging	X		X	
Three Premises Bridging	X	X		X

(1) Central Office Bridging Capability:

(a) Series Bridging

Bridging of up to 26 customer designated premises.

(b) Three Premises Bridging

Provision of tip-to-tip and ring-to-ring connection in a central office of a metallic pair to a third customer designated premises.

{1} Effective June 30, 2021, this Service will no longer be available for purchase by new or existing customers. In addition, requests to move, add, change, or renew existing service arrangements will not be accepted. Following the expiration of a customer's existing term agreement, service will be provided on a month-to-month basis at the applicable Monthly rates until the service is discontinued. The Company currently plans to discontinue this service on or after June 30, 2024.

SPECIAL ACCESS SERVICE

7.3 Service Descriptions, Rates and Charges (Cont'd)

7.3.2 Metallic Service {1}

(E) Rates and Charges

Each rate element is shown with its associated USOC, where appropriate.

	<u>Monthly Rate</u>	<u>Nonrecurring</u>
	<u>Fixed</u>	<u>Charge</u>
	<u>Per Mile</u>	
(1) <u>Channel Termination</u> (T6ECS)		
Per point of termination	\$ 17.91	\$ 75.80
(2) <u>Channel Mileage</u> (1L5XX)		
0 miles	0.00	0.00
Over 0 miles	0.00	14.57
(3) <u>Series Bridging</u> (BCNMS)		
Per Port	4.92	0.00
(4) <u>Three Premises Bridging</u> (BCNM3)		
Per Port	4.92	0.00

{1} Effective June 30, 2021, this Service will no longer be available for purchase by new or existing customers. In addition, requests to move, add, change, or renew existing service arrangements will not be accepted. Following the expiration of a customer's existing term agreement, service will be provided on a month-to-month basis at the applicable Monthly rates until the service is discontinued. The Company currently plans to discontinue this service on or after June 30, 2024.

SPECIAL ACCESS SERVICE

7.3 Service Descriptions, Rates and Charges (Cont'd)

7.3.3 Telegraph Grade Service {1}

(A) Basic Channel Description

A Telegraph Grade channel is an unconditional channel capable of transmitting binary signals at rates of 0-75 baud or 0-150 baud. This channel is furnished for half-duplex or duplex operation. Telegraph Grade channels are provided between customer designated premises or between a customer designated premises and a SWBT hub.

(B) Technical Specifications Packages

Transmission Parameter	Package TG-
Telegraph Distortion	$\frac{C}{X}$ $\frac{1}{X}$ $\frac{2}{X}$

(C) Channel Interfaces (CI)

Following are channel interfaces normally associated with Telegraph Grade Service.

CI	Definition
DB10	108 Data Set
DB43	43 Telegraph Carrier
IA	E.I.A. RS-232
TT2	20 Ma
TT3	3 Ma
TT6	62.5 Ma

(D) (Reserved for Future Use)

{1} Effective June 30, 2021, this Service will no longer be available for purchase by new or existing customers. In addition, requests to move, add, change, or renew existing service arrangements will not be accepted. Following the expiration of a customer's existing term agreement, service will be provided on a month-to-month basis at the applicable Monthly rates until the service is discontinued. The Company currently plans to discontinue this service on or after June 30, 2024.

SPECIAL ACCESS SERVICE

7.3 Service Descriptions, Rates and Charges (Cont'd)

7.3.3 Telegraph Grade Service {1}

(E) Rates and Charges

Each rate element is shown with its associated USOC, where appropriate.

	<u>Monthly</u>	<u>Rate</u>	<u>Nonrecurring</u>
	<u>Fixed</u>	<u>Per Mile</u>	<u>Charge</u>
(1) <u>Channel Termination</u>			
Per point of termination			
Two-wire (T6E2X)	\$ 24.22		\$ 75.80
Four-wire (T6E4X)	44.71		75.80
(2) <u>Channel Mileage (1L5XX)</u>			
0 miles	0.00	0.00	
Over 0 to 4	16.97	3.56	
Over 4 to 8	16.97	3.56	
Over 8 to 25	19.46	3.24	
Over 25 to 50	34.20	2.66	
Over 50	34.20	2.66	

{1} Effective June 30, 2021, this Service will no longer be available for purchase by new or existing customers. In addition, requests to move, add, change, or renew existing service arrangements will not be accepted. Following the expiration of a customer's existing term agreement, service will be provided on a month-to-month basis at the applicable Monthly rates until the service is discontinued. The Company currently plans to discontinue this service on or after June 30, 2024.

SPECIAL ACCESS SERVICE

7.3 Service Descriptions, Rates and Charges (Cont'd)

7.3.4 Voice Grade Service⁴

(A) Basic Channel Description

A Voice Grade channel is a channel which provides voice frequency transmission capability in the nominal frequency range of 300 to 3000 hertz (Hz) and may be terminated two-wire or four-wire. Voice Grade channels are provided between customer designated premises, or between a customer designed premises and a SWBT hub.

(B) Technical Specification Packages

Transmission Parameter	<u>C</u> ¹	<u>1</u>	<u>2</u>	<u>3</u>	<u>4</u>	Package VG-											
						<u>5</u>	<u>6</u>	<u>7</u>	<u>8</u>	<u>9</u>	<u>10</u>	<u>11</u>	<u>12</u>	<u>W</u> ²			
Attenuation																	
Distortion	X	X	X	X	X	X	X	X	X	X	X	X	X	X			
C-Message Noise	X	X	X	X	X	X	X	X	X	X	X	X	X	X			
Echo Control	X	X	X	X		X		X	X					X ³			
Envelope Delay																	
Distortion	X						X	X	X	X	X	X	X	X			
Frequency Shift	X						X	X	X	X	X	X	X	X			
Impulse Noise	X					X	X	X	X	X	X	X	X	X			
Intermodulation																	
Distortion	X						X	X	X	X	X	X		X			
Loss Deviation	X	X	X	X	X	X	X	X	X	X	X	X	X	X			
Phase Hits, Gain Hits, and Dropouts	X					X	X	X	X	X	X	X	X				
Phase Jitter	X						X	X	X	X	X	X		X			
Signal-to-C Message Noise					X												
Signal-to-C Notch Noise	X					X	X	X	X	X	X	X	X	X			

{1} The desired parameters are selected by the customer from the list of available parameters.

{2} Denotes WATS Access Lines (WALs).

{3} When WAL extensions are provided, Echo Control limits are not applicable.

{4} Effective June 30, 2021, this Service will no longer be available for purchase by new or existing customers. In addition, requests to move, add, change, or renew existing service arrangements will not be accepted. Following the expiration of a customer's existing term agreement, service will be provided on a month-to-month basis at the applicable Monthly rates until the service is discontinued. The Company currently plans to discontinue this service on or after June 30, 2024.

SPECIAL ACCESS SERVICE

7.3 Service Descriptions, Rates and Charges (Cont'd)

7.3.4 Voice Grade Service {2} (Cont'd)

(C) Channel Interfaces (CI)

The following channel interfaces are for Voice Grade Service.

<u>CI</u>	<u>Signaling Capability Required</u>	<u>Signaling Not Required</u>
AB	X	
AC	X	
AH		X
CT	X	
DA		X
DB		X
DD		X
DE		X
DS		X
DX	X	
DY	X	
EA	X	
EB	X	
EC	X	
EX	X	
GO	X	
GS	X	
LA	X	
LB	X	
LC	X	
LO	X	
LR	X	
LS	X	
NO		X
PR		X
RV	X	
SF	X	
TF		X

The following channel interfaces are for WALs {2}.

<u>CI</u>	<u>Signaling {1} Required</u>	<u>Signaling Not Required</u>
DS	X	
GS	X	
LS	X	

(D) (Reserved for Future Use)

(E) Four-Wire/Two-Wire Conversion

When a customer requests that an effective four-wire channel be terminated with a two-wire channel interface at the customer designated premises, a four-wire to two-wire conversion is required. The rate for the conversion is included as part of the basic Channel Termination rate.

{1} Signaling as defined in 6.4.2 (Local Transport Features).

{2} Effective June 30, 2021, this Service will no longer be available for purchase by new or existing customers. In addition, requests to move, add, change, or renew existing service arrangements will not be accepted. Following the expiration of a customer's existing term agreement, service will be provided on a month-to-month basis at the applicable Monthly rates until the service is discontinued. The Company currently plans to discontinue this service on or after June 30, 2024.

SPECIAL ACCESS SERVICE

7.3 Service Descriptions, Rates and Charges (Cont'd)

7.3.4 Voice Grade Service{5} (Cont'd)

(F) Optional Features and Functions

	<u>C</u>	<u>1</u>	<u>2</u>	<u>3</u>	<u>4</u>	Package VG-			<u>8</u>	<u>9</u>	<u>10</u>	<u>11</u>	<u>12</u>	<u>W</u> ¹
Central Office Bridging Capability	X		X			X	X				X	X	X	
C-Conditioning C-Type	X					X	X	X	X	X	X			
Conditioning {2}	X					X	X	X	X	X	X			
Data Capability Improved	X						X				X			
Attenuation Distortion {3}	X					X	X	X	X	X	X			X
Improved Return Loss at two-wire POT	X		X	X				X						
Improved Termination at four-wire POT	X	X	X	X	X	X	X	X	X	X	X	X	X	
Sealing Current Conditioning	X					X	X				X			
Signaling Capability	X	X	X	X				X	X	X				{4}

{1} Denotes WATS Access Lines (WALs).
 {2} Obsolete, and limited to existing installations at existing locations, for existing customers as of February 8, 1989.
 {3} Obsolete -- Applicable to existing installations at existing locations for existing customers.
 {4} Signaling is provided in conjunction with Switched Access service, 6.4.2 Local Transport Features).
 {5} Effective June 30, 2021, this Service will no longer be available for purchase by new or existing customers. In addition, requests to move, add, change, or renew existing service arrangements will not be accepted. Following the expiration of a customer's existing term agreement, service will be provided on a month-to-month basis at the applicable Monthly rates until the service is discontinued. The Company currently plans to discontinue this service on or after June 30, 2024.

SPECIAL ACCESS SERVICE

7.3 Service Descriptions, Rates and Charges (Cont'd)

7.3.4 Voice Grade Service{3} (Cont'd)

(F) Optional Features and Functions (Cont'd)

(1) Central Office Bridging Capability

- (a) Data Bridging (two-wire and four-wire)
- (b) (Reserved for Future Use)
- (c) Telemetry and Alarm Bridging:
Split Band, Active Bridging
Summation, Active Bridging {1}
- (d) (Reserved for Future Use)
- (e) Voice Bridging (two-wire and four-wire)

(2) (Reserved for Future Use)

(3) Conditioning

Conditioning provides more specific transmission characteristics for Voice Grade services. C-Type conditioning controls attenuation distortion and envelope delay distortion. Sealing Current helps maintain continuity on dry metallic{3} loops.

For two-point services, the parameters apply to each service. For multipoint services, the parameters apply to each mid link or end link. C-Type conditioning and Data Capability may be combined on the same service.

(a) C-Conditioning

C-Conditioning upgrades the frequency response and envelope delay distortion limits of the analog data channel. The specifications for C-Conditioning, which are less stringent than C-Type conditioning, are delineated in the appropriate Technical Reference for Voice Grade Service.

(b) C-Type Conditioning {2}

C-Type Conditioning is provided for the additional control of attenuation distortion and envelope delay distortion on data services. The attenuation distortion and envelope delay distortion specifications for C-Type Conditioning are delineated in the appropriate Technical Reference for Voice Grade Service.

- {1} Obsolete -- Applicable to existing installations at existing locations for existing customers.
- {2} This feature is obsolete, and limited to existing installations at existing locations, for existing customers as of February 8, 1989.
- {3} Effective June 30, 2021, this Service will no longer be available for purchase by new or existing customers. In addition, requests to move, add, change, or renew existing service arrangements will not be accepted. Following the expiration of a customer's existing term agreement, service will be provided on a month-to-month basis at the applicable Monthly rates until the service is discontinued. The Company currently plans to discontinue this service on or after June 30, 2024.

SPECIAL ACCESS SERVICE

7.3 Service Descriptions, Rates and Charges (Cont'd)

7.3.4 Voice Grade Service{2} (Cont'd)

(F) Optional Features and Functions (Cont'd)

(3) Conditioning (Cont'd)

(c) Improved Attenuation Distortion (IAD) {1}

Improved Attenuation Distortion upgrades the frequency response limits of the analog data channel. The specifications for Improved Attenuation Distortion are delineated in the appropriate Technical References for WAL{2} application and Voice Grade Services.

(d) (Reserved for Future Use)

(e) Sealing Current Conditioning

Sealing Current Conditioning is provided to help maintain continuity on dry metallic{2} loops. It is associated with four-wire DA or NO type channel interfaces.

(4) Data Capability

Data Capability provides transmission characteristics suitable for data communications. Specifically, Data Capability provides for the control of Signal to C-Notched Noise Ratio and intermodulation distortion.

The Signal to C-Notched Noise Ratio and intermodulation distortion specifications for Data Capability are delineated in the appropriate Technical Reference for Voice Grade Service.

When a service equipped with Data Capability is used for voice communications, the quality of the voice transmission may not be satisfactory.

(5) (Reserved for Future Use)

(6) (Reserved for Future Use)

(7) Improved Return Loss

Improved Return Loss at a two-wire point of termination provides for more stringent Echo Control specifications. This option is only applicable when ordered on effective two-wire channels and the transmission path is four-wire at one POT and two-wire at the other POT. Specifications can only be met with limited facility configurations. The Improved Return Loss specifications are delineated in the appropriate Technical Reference for Voice Grade Service.

{1} Obsolete -- Applicable to existing installations at existing locations for existing customers.

{2} Effective June 30, 2021, this Service will no longer be available for purchase by new or existing customers. In addition, requests to move, add, change, or renew existing service arrangements will not be accepted. Following the expiration of a customer's existing term agreement, service will be provided on a month-to-month basis at the applicable Monthly rates until the service is discontinued. The Company currently plans to discontinue this service on or after June 30, 2024.

SPECIAL ACCESS SERVICE

7.3 Service Descriptions, Rates and Charges (Cont'd)

7.3.4 Voice Grade Service{1} (Cont'd)

(F) Optional Features and Functions (Cont'd)

(8) Improved Termination

Improved Termination at a four-wire point of termination provides, for a fixed 600 ohm impedance, variable level range and simplex reversal capability when ordered with either an effective two-wire or four-wire channel. SWBT equipment is required at the customer's premises where this option is ordered. The Improved Termination specifications are delineated in the appropriate Technical Reference for Voice Grade Service.

(9) Signaling Capability

Signaling Capability provides for the process by which one customer premises alerts another customer premises on the same service with which it wishes to communicate.

{1} Effective June 30, 2021, this Service will no longer be available for purchase by new or existing customers. In addition, requests to move, add, change, or renew existing service arrangements will not be accepted. Following the expiration of a customer's existing term agreement, service will be provided on a month-to-month basis at the applicable Monthly rates until the service is discontinued. The Company currently plans to discontinue this service on or after June 30, 2024.

SPECIAL ACCESS SERVICE

7.3 Service Descriptions, Rates and Charges (Cont'd)

7.3.4 Voice Grade Service{2} (Cont'd)

(G) Rates and Charges

Each rate element is shown with its associated USOC, were appropriate.

	<u>Monthly Rate</u>	<u>Nonrecurring</u>
(1) <u>Channel Termination</u>	<u>Fixed</u>	<u>Per Mile</u>
		<u>Charge</u>
Per point of termination		
Two-wire (T6E2X)	\$ 25.84	\$ 78.05
Four-wire (T6E4X)	44.68	78.05
 WATS Access Line{2} Termination		
- Applicable to non-Joint provided intrastate interLATA only WATS and 800	40.50	78.05
 Digital WAL {1}{2} (T6EDX)	0.00	0.00
 (2) <u>Channel Mileage (1L5XX)</u>		
0 miles	0.00	0.00
Over 0 to 4	15.56	3.26
Over 4 to 8	15.56	3.26
Over 8 to 25	17.84	2.98
Over 25 to 50	31.34	2.44
Over 50	31.34	2.44
 (3) (Reserved for Future Use)		
 (4) <u>Data Bridging</u>		
Per port		
Two-wire (BCND2)	4.51	0.00
Four-wire (BCND4)	4.51	0.00

{1} Additive available in conjunction with customer ordered Digital High Capacity facility in 7.3.10 (High Capacity Service).

{2} Effective June 30, 2021, this Service will no longer be available for purchase by new or existing customers. In addition, requests to move, add, change, or renew existing service arrangements will not be accepted. Following the expiration of a customer's existing term agreement, service will be provided on a month-to-month basis at the applicable Monthly rates until the service is discontinued. The Company currently plans to discontinue this service on or after June 30, 2024.

SPECIAL ACCESS SERVICE

7.3 Service Descriptions, Rates and Charges (Cont'd)

7.3.4 Voice Grade Service{2} (Cont'd)

(G) Rates and Charges (Cont'd)

	<u>Fixed</u>	<u>Monthly Rate Per Mile</u>	<u>Nonrecurring Charge</u>
(5) (Reserved for Future use)			
(6) <u>Telemetry and Alarm Bridging</u>			
<u>Active Bridging Channel Connections</u>			
Split Band, per channel connected (CNLRX)	0.71		0.00
Summation, per channel connected (BCNSA) {1}	3.02		0.00
(7) (Reserved for Future Use)			
(8) <u>Voice Bridging</u>			
Per port			
Two-wire (BCNV2)	4.51		0.00
Four-wire (BCNV4)	4.51		0.00

{1} Obsolete -- Applicable to existing installations at existing locations for existing customers.

{2} Effective June 30, 2021, this Service will no longer be available for purchase by new or existing customers. In addition, requests to move, add, change, or renew existing service arrangements will not be accepted. Following the expiration of a customer's existing term agreement, service will be provided on a month-to-month basis at the applicable Monthly rates until the service is discontinued. The Company currently plans to discontinue this service on or after June 30, 2024.

SPECIAL ACCESS SERVICE

7.3 Service Descriptions, Rates and Charges (Cont'd)

7.3.4 Voice Grade Service{3} (Cont'd)

(G) Rates and Charges (Cont'd)

	<u>Monthly</u> <u>Fixed</u>	<u>Rate</u> <u>Per Mile</u>	<u>Nonrecurring</u> <u>Charge</u>
(9) (Reserved for Future Use)			
(10) <u>Conditioning</u>			
<u>C-Type {1}</u>			
Per point of termination (X1CPT)	3.08		0.00
<u>Improved Attenuation Distortion (IAD) {2}</u>			
Per WAL{3} point of termination (ORA)	0.00		0.00
<u>Sealing Current Conditioning (1HBPT)</u>			
Per point of termination	0.00		0.00
(11) <u>Data Capability</u>			
Per point of termination (XDCPT)	4.47		234.00
(12) (Reserved for Future Use)			
(13) (Reserved for Future Use)			
(14) <u>Improved Return Loss</u>			
Per two-wire point of termination (1RL2W)	3.20		0.00
(15) <u>Improved Termination</u>			
Per four-wire point of termination (1RL4W)	3.20		0.00

- {1} Obsolete, and limited to existing installations at existing location, for existing customers as of February 8, 1989.
- {2} Obsolete -- Applicable to existing installations at existing locations for existing customers.
- {3} Effective June 30, 2021, this Service will no longer be available for purchase by new or existing customers. In addition, requests to move, add, change, or renew existing service arrangements will not be accepted. Following the expiration of a customer's existing term agreement, service will be provided on a month-to-month basis at the applicable Monthly rates until the service is discontinued. The Company currently plans to discontinue this service on or after June 30, 2024.

President - Texas
AT&T Texas
Dallas, Texas
Issued: May 9, 2024
Effective: May 10, 2024

ACCESS SERVICE TARIFF
Section: 7
Sheet: 57
Revision: 3
Replacing: 2

SPECIAL ACCESS SERVICE

7.3 Service Descriptions, Rates and Charges (Cont'd)

7.3.4 Voice Grade Service{2} (Cont'd)

(G) Rates and Charges (Cont'd)

	<u>Monthly Rate</u>	<u>Nonrecurring</u>
	<u>Fixed</u>	<u>Charge</u>
	<u>Per Mile</u>	
(16) (Reserved for Future Use)		
(17) <u>Signaling</u> <u>Capability</u>		
Per point of termination (XSS++) {1}	15.25	0.00
(18) (Reserved for Future Use)		
(19) (Reserved for Future Use)		

{1} In lieu of ++, substitute appropriate two digit code from the following list to specify type of signaling:

AB AC CT DX DY EA EB EC EX GO GS LA LB LC LO LR LS RV SF

{2} Effective June 30, 2021, this Service will no longer be available for purchase by new or existing customers. In addition, requests to move, add, change, or renew existing service arrangements will not be accepted. Following the expiration of a customer's existing term agreement, service will be provided on a month-to-month basis at the applicable Monthly rates until the service is discontinued. The Company currently plans to discontinue this service on or after June 30, 2024.

President - Texas
AT&T Texas
Dallas, Texas
Issued: May 9, 2024
Effective: May 10, 2024

ACCESS SERVICE TARIFF
Section: 7
Sheet: 58
Revision: 2
Replacing: 1

SPECIAL ACCESS SERVICE

7.3 Service Descriptions, Rates and Charges (Cont'd)

7.3.4 Voice Grade Service{1} (Cont'd)

(G) Rates and Charges (Cont'd)

	<u>Monthly Rate</u>	<u>Nonrecurring</u>
	<u>Fixed</u>	<u>Charge</u>
	<u>Per Mile</u>	
(20) (Reserved for Future Use)		
(21) (Reserved for Future Use)		
(22) (Reserved for Future Use)		
(23) (Reserved for Future Use)		
(24) (Reserved for Future Use)		

{1} Effective June 30, 2021, this Service will no longer be available for purchase by new or existing customers. In addition, requests to move, add, change, or renew existing service arrangements will not be accepted. Following the expiration of a customer's existing term agreement, service will be provided on a month-to-month basis at the applicable Monthly rates until the service is discontinued. The Company currently plans to discontinue this service on or after June 30, 2024.

President - Texas
AT&T Texas
Dallas, Texas
Issued: May 9, 2024
Effective: May 10, 2024

ACCESS SERVICE TARIFF
Section: 7
Sheet: 59
Revision: 4
Replacing: 3

SPECIAL ACCESS SERVICE

7.3 Service Descriptions, Rates and Charges (Cont'd)

7.3.5 Reserved for future use

President - Texas
AT&T Texas
Dallas, Texas
Issued: May 9, 2024
Effective: May 10, 2024

ACCESS SERVICE TARIFF
Section: 7
Sheet: 60
Revision: 4
Replacing: 3

SPECIAL ACCESS SERVICE

7.3 Service Descriptions, Rates and Charges (Cont'd)

7.3.5 Reserved for future use

President - Texas
AT&T Texas
Dallas, Texas
Issued: May 9, 2024
Effective: May 10, 2024

ACCESS SERVICE TARIFF
Section: 7
Sheet: 61
Revision: 4
Replacing: 3

SPECIAL ACCESS SERVICE

7.3 Service Descriptions, Rates and Charges (Cont'd)

7.3.5 Reserved for future use

President - Texas
AT&T Texas
Dallas, Texas
Issued: May 9, 2024
Effective: May 10, 2024

ACCESS SERVICE TARIFF
Section: 7
Sheet: 62
Revision: 3
Replacing: 2

SPECIAL ACCESS SERVICE

7.3 Service Descriptions, Rates and Charges (cont'd)

7.3.6 (Reserved for future use)

President - Texas
AT&T Texas
Dallas, Texas
Issued: May 9, 2024
Effective: May 10, 2024

ACCESS SERVICE TARIFF
Section: 7
Sheet: 62.1
Revision: 2
Replacing: 1

SPECIAL ACCESS SERVICE

President - Texas
AT&T Texas
Dallas, Texas
Issued: May 9, 2024
Effective: May 10, 2024

ACCESS SERVICE TARIFF
Section: 7
Sheet: 62.2
Revision: 2
Replacing: 1

SPECIAL ACCESS SERVICE

President - Texas
AT&T Texas
Dallas, Texas
Issued: May 9, 2024
Effective: May 10, 2024

ACCESS SERVICE TARIFF
Section: 7
Sheet: 63
Revision: 2
Replacing: 1

SPECIAL ACCESS SERVICE

7.3 Service Descriptions, Rates and Charges (Cont'd)

7.3.7

President - Texas
AT&T Texas
Dallas, Texas
Issued: May 9, 2024
Effective: May 10, 2024

ACCESS SERVICE TARIFF
Section: 7
Sheet: 64
Revision: 2
Replacing: 1

SPECIAL ACCESS SERVICE

7.3 Service Descriptions, Rates and Charges (Cont'd)

7.3.7

President - Texas
AT&T Texas
Dallas, Texas
Issued: May 9, 2024
Effective: May 10, 2024

ACCESS SERVICE TARIFF
Section: 7
Sheet: 65
Revision: 2
Replacing: 1

SPECIAL ACCESS SERVICE

7.3 Service Descriptions, Rates and Charges (Cont'd)

7.3.7

President - Texas
AT&T Texas
Dallas, Texas
Issued: May 9, 2024
Effective: May 10, 2024

ACCESS SERVICE TARIFF
Section: 7
Sheet: 66
Revision: 2
Replacing: 1

SPECIAL ACCESS SERVICE

7.3 Service Descriptions, Rates and Charges (Cont'd)

7.3.8

President - Texas
AT&T Texas
Dallas, Texas
Issued: May 9, 2024
Effective: May 10, 2024

ACCESS SERVICE TARIFF
Section: 7
Sheet: 67
Revision: 2
Replacing: 1

SPECIAL ACCESS SERVICE

7.3 Service Descriptions, Rates and Charges (Cont'd)

7.3.8

SPECIAL ACCESS SERVICE

7.3 Service Descriptions, Rates and Charges (Cont'd)

7.3.9 Digital Link{1}

(A) Basic Channel Description

A Digital Link channel provided as a Package 1-4 and referred to as MegaLink II Premium Digital Service is a channel for duplex four-wire transmission of synchronous serial data at the rate of 2.4, 4.8, 9.6, or 56 kbps. The actual bit rate is a function of the channel interface selected by the customer. The channel provides a synchronous service with timing provided by SWBT through SWBT's facilities to the customer in the received bit stream. Digital Link channels are provided between customer designated premises for two-point service or between a customer designated premises and a SWBT digital hub for multipoint or multiplexed service.

A Digital Link Service channel provided as a Package 6-9 and referred to as MegaLink Digital Service is a channel for duplex four-wire transmission of synchronous serial data at the rate of 2.4, 4.8, 9.6 or 56 kbps. The actual bit rate is a function of the channel interface selected by the customer. The channel provides a synchronous service that may be independently timed when access to a nationwide synchronization network is not available. MegaLink channels are only available via SWBT designated hubs.

When a single Digital Link channel is ordered to be terminated at a customer's designated Interexchange Carrier's all-digital POP which requires a minimum digital interface level of 1.544 Mbps, SWBT will provide the required interface where facilities are available.

It is the customer's responsibility to arrange for the Channel Service Unit-type equipment or other Network Channel Terminating Equipment associated with the Digital Link channel at the customer premises.

(B) Technical Specifications Packages

Transmission Parameter	<u>1</u>	<u>2</u>	<u>3</u>	<u>4</u>	<u>6</u>	<u>7</u>	<u>8</u>	<u>9</u>
Error-Free Seconds	X	X	X	X	NA	NA	NA	NA

SWBT will provide a channel capable of meeting a monthly average performance greater than or equal to 99.875% error-free seconds while the channel is in service, if it is measured through a CSU equivalent which is designed, manufactured, and maintained to conform with the specifications contained in the appropriate Technical Reference for Digital Link Service.

For MegaLink Digital Service, SWBT will provide a channel capable of meeting the technical parameters as set forth in the appropriate Technical Reference for Digital Link Service at SWBT's demarcation point.

Voltages which are compatible with Digital Link Service are delineated in the appropriate Technical Reference for Digital Link Service.

{1} Effective June 30, 2021, this Service will no longer be available for purchase by new or existing customers. In addition, requests to move, add, change, or renew existing service arrangements will not be accepted. Following the expiration of a customer's existing term agreement, service will be provided on a month-to-month basis at the applicable Monthly rates until the service is discontinued. The Company currently plans to discontinue this service on or after June 30, 2024.

SPECIAL ACCESS SERVICE

7.3 Service Descriptions, Rates and Charges (Cont'd)

7.3.9 Digital Link{1} (Cont'd)

(C) Channel Interfaces (CI)

The following channel interfaces define the bit rates that are available for a Digital Link channel:

CI	Bit Rate
DU-24	2.4 kbps (DL1 or DL6)
DU-48	4.8 kbps (DL2 or DL7)
DU-96	9.6 kbps (DL3 or DL8)
DU-56	56 kbps (DL4 or DL9)

(D) (Reserved for Future Use)

(E) Optional Features and Functions

	<u>1</u>	<u>2</u>	Package DL-		<u>6</u>	<u>7</u>	<u>8</u>	<u>9</u>
			<u>3</u>	<u>4</u>				
Central Office Bridging Capability	X	X	X	X	NA	NA	NA	NA
Secondary Channel Capability	X	X	X	X	NA	NA	NA	NA

(1) Central Office Bridging Capability

The capability of a central office to connect one circuit to another circuit. Central office bridging capability is specified in SWBT's FCC Tariff No. 4.

(2) Secondary Channel Capability

Secondary Channel Capability provides for an additional low-speed digital transmission channel within the existing 2.4, 4.8, 9.6, and 56 kbps primary channels. It is available as a point-to-point or a multipoint service utilizing a nonrepeated channel termination. The Secondary Channel can be used as a communications channel for the controlling and monitoring of the customer's network.

{1} Effective June 30, 2021, this Service will no longer be available for purchase by new or existing customers. In addition, requests to move, add, change, or renew existing service arrangements will not be accepted. Following the expiration of a customer's existing term agreement, service will be provided on a month-to-month basis at the applicable Monthly rates until the service is discontinued. The Company currently plans to discontinue this service on or after June 30, 2024.

SPECIAL ACCESS SERVICE

7.3 Service Descriptions, Rates and Charges (Cont'd)

7.3.9 Digital Link{2} (Cont'd)

(F) Rates and Charges

Each rate element is shown with its associated USOC, where appropriate.

(1) <u>Channel Termination</u> (T6ECS)	<u>Monthly Rate</u>	<u>Nonrecurring Charge</u>
Per point of termination		
2.4 kbps DL1	\$ 85.39	\$ 148.00
4.8 kbps DL2	80.59	148.00
9.6 kbps DL3	81.63	148.00
56 kbps DL4	138.19	224.00
2.4 kbps DL6 {1}	For rates - refer to	
4.8 kbps DL7 {1}	Digital Link Service	
9.6 kbps DL8 {1}	Tariff - Section 2, 4.1.1	
56 kbps DL9 {1}	MegaLink Digital Service	

(2) <u>Channel Mileage</u> (1L5XX)	<u>Monthly Rates</u>		<u>Nonrecurring Charge</u>
	<u>Fixed</u>	<u>Per Mile</u>	
2.4 kbps (DL1) <u>Mileage Bands</u>			
0 miles	0.00	0.00	
Over 0 to 4	69.50	3.13	
Over 4 to 8	75.79	1.57	
Over 8 to 25	82.07	0.79	
Over 25 to 50	91.87	0.39	
Over 50	97.84	0.27	
4.8 kbps (DL2) <u>Mileage Bands</u>			
0 miles	0.00	0.00	
Over 0 to 4	69.37	1.81	
Over 4 to 8	69.37	1.81	
Over 8 to 25	74.79	1.13	
Over 25 to 50	77.81	1.02	
Over 50	77.81	1.02	
9.6 kbps (DL3) <u>Mileage Bands</u>			
0 miles	0.00	0.00	
Over 0 to 4	101.37	2.86	
Over 4 to 8	101.37	2.86	
Over 8 to 25	112.01	1.53	
Over 25 to 50	119.37	1.22	
Over 50	119.37	1.22	

{1} Inside wire charges are not applicable on DL6-9.

{2} Effective June 30, 2021, this Service will no longer be available for purchase by new or existing customers. In addition, requests to move, add, change, or renew existing service arrangements will not be accepted. Following the expiration of a customer's existing term agreement, service will be provided on a month-to-month basis at the applicable Monthly rates until the service is discontinued. The Company currently plans to discontinue this service on or after June 30, 2024.

SPECIAL ACCESS SERVICE

7.3 Service Descriptions, Rates and Charges (Cont'd)

7.3.9 Digital Link{1} (Cont'd)

(F) Rates and Charges (Cont'd)

(2) Channel Mileage (Cont'd)

	<u>Monthly Rate</u>	<u>Nonrecurring Charge</u>
	<u>Fixed</u>	<u>Per Mile</u>
56 kbps (DL4)		
<u>Mileage Bands</u>		
0 miles	\$ 0.00	\$ 0.00
Over 0 to 4	164.91	7.38
Over 4 to 8	173.32	5.27
Over 8 to 25	194.43	2.65
Over 25 to 50	194.43	2.65
Over 50	194.43	2.65

2.4 kbps (DL6)
 End-User or IC's For rates - refer to
 - Wire Center to Digital Link Service
 Standard-Digital Tariff - Section 2, 4.1.2 and 4.2
 Serving Hub MegaLink Digital Service
 - Hub to Hub

4.8 kbps (DL7)
 End-User or IC's For rates - refer to
 - Wire Center to Digital Link Service
 Standard-Digital Tariff - Section 2, 4.1.2 and 4.2
 Serving Hub MegaLink Digital Service
 - Hub to Hub

9.6 kbps (DL8)
 End-User or IC's For rates - refer to
 - Wire Center to Digital Link Service
 Standard-Digital Tariff - Section 2, 4.1.2 and 4.2
 Serving Hub MegaLink Digital Service
 - Hub to Hub

56 kbps (DL9)
 End-User or IC's For rates - refer to
 - Wire Center to Digital Link Service
 Standard-Digital Tariff - Section 2, 4.1.2 and 4.2
 Serving Hub MegaLink Digital Service
 - Hub to Hub

(3) **(Reserved for Future Use)**

(4) <u>Bridging</u> (BCNDA)		
Per Port		
MegaLink I	18.00	\$ 0.00
MegaLink II	9.88	0.00

(5) <u>Secondary Channel</u>		
<u>Capability</u> (SCA)		
Per channel		
termination		
For all speeds	9.89	112.00

{1} Effective June 30, 2021, this Service will no longer be available for purchase by new or existing customers. In addition, requests to move, add, change, or renew existing service arrangements will not be accepted. Following the expiration of a customer's existing term agreement, service will be provided on a month-to-month basis at the applicable Monthly rates until the service is discontinued. The Company currently plans to discontinue this service on or after June 30, 2024.

President - Texas
AT&T Texas
Dallas, Texas
Issued: May 9, 2024
Effective: May 10, 2024

ACCESS SERVICE TARIFF
Section: 7
Sheet: 72
Revision: 2
Replacing: 1

SPECIAL ACCESS SERVICE

7.3 Service Descriptions, Rates and Charges (Cont'd)

7.3.9 Digital Link (Cont'd)

(F) Rates and Charges (Cont'd)

SPECIAL ACCESS SERVICE

7.3 Service Descriptions, Rates and Charges (Cont'd)

7.3.10 High Capacity Service

(A) Basic Channel Description

A High Capacity channel is a channel for the transmission of nominal 64.0 kbps {1}{3}, 1.544 Mbps, or 44.736 Mbps isochronous serial digital data. The actual bit rate and framing format is a function of the channel interface selected by the customer. High Capacity channels are provided: [1] between customer designated premises; [2] between a customer designated premises and a SWBT hub; [3] between Network Reconfiguration Service (NRS) hubs; or [4] between an NRS hub and a SWBT hub.

It is the customer's responsibility to arrange for the Network Channel Terminating Equipment associated with the High Capacity channel at the customer's premises.

(B) Technical Specifications Packages

Transmission		Package HC-	
<u>Parameter</u>	<u>0</u>	<u>1</u>	<u>3</u>
Error-Free Seconds		X	

A channel with technical specifications package HC1 will be capable of an error-free second performance of 98.75% over a continuous 24 hour period as measured at the 1.544 Mbps rate through a Channel Service Unit equivalent which is designed, manufactured, and maintained to conform with the specifications contained in the appropriate Technical Reference for High Capacity Service.

(C) Channel Interfaces (CI)

The following channel interfaces define the bit rate that is available for a High Capacity DS1 channel:

<u>CI</u>	<u>Bit Rate</u>
DS-15{2}{3}	1.544 Mbps (DS1)
DS-44	44.736 Mbps (DS3)

(D) Reserved for Future Use

- {1} Available only as a channel of a 1.544 Mbps facility between two SWBT Digital Link hubs. The customer must provide system and channel assignment data.
- {2} A 64.0 kbps channel is available as a channel(s) of a 1.544 Mbps facility to a SWBT hub.
- {3} Effective June 30, 2021, 64.0 Kbps will no longer be available for purchase by new or existing customers. In addition, requests to move, add, change, or renew existing service arrangements will not be accepted. Following the expiration of a customer's existing term agreement, service will be provided on a month-to-month basis at the applicable Monthly rates until the service is discontinued. The Company currently plans to discontinue this service on or after June 30, 2024.

SPECIAL ACCESS SERVICE

7.3 Service Descriptions, Rates and Charges (Cont'd)

7.3.10 High Capacity Service (Cont'd)

(E) Optional Features and Functions

	Package HC-		
	<u>0</u>	<u>1</u>	<u>3</u>
Central Office Multiplexing			
DS0 to Subrate* ⁽¹⁾	X		
DS1 to DS0		X	
DS1 to Voice		X	
DS3 to DS1			X
Clear Channel Capability		X	
Extended Superframe Format		X	

*Available only on a channel of 1.544 Mbps facility to a SWBT hub or on a DS0 channel⁽¹⁾ that connects to a customer's Network Reconfiguration Service (NRS) network which contains a DS1 channel.

(1)

(2) Central Office Multiplexing

(a) DS0 to Subrate⁽¹⁾

An arrangement that converts a 64.0 Kbps channel to subspeeds of up to twenty 2.4 Kbps, ten 4.8 Kbps, or five 9.6 Kbps channels using digital time division multiplexing.

(b) DS1 to DS0

An arrangement that converts a 1.544 Mbps channel to 23 64.0 Kbps channels utilizing digital time division multiplexing.

(c) DS1 to Voice

An arrangement that converts a 1.544 Mbps channel to 24 channels for use with Voice Grade⁽¹⁾ Services. A channel of this DS1 to the hub can also be used for Digital Link⁽¹⁾ for Metallic Service.⁽¹⁾

(1) Effective June 30, 2021, this Service will no longer be available for purchase by new or existing customers. In addition, requests to move, add, change, or renew existing service arrangements will not be accepted. Following the expiration of a customer's existing term agreement, service will be provided on a month-to-month basis at the applicable Monthly rates until the service is discontinued. The Company currently plans to discontinue this service on or after June 30, 2024.

SPECIAL ACCESS SERVICE

7.3 Service Descriptions, Rates and Charges (Cont'd)

7.3.10 High Capacity Service (Cont'd)

(E) Optional Features and Functions

(2) Central Office Multiplexing

(d) DS3 to DS1

An arrangement that converts a 44.736 Mbps channel to 28 DS1 channels using digital time division multiplexing.

(3) Clear Channel Capability

Clear Channel Capability is an optional feature that provides the customer with an increase in usable bandwidth from 1.344 Mbps to 1.536 Mbps of an unconstrained data stream across the network. Clear Channel Capability is provided on 1.544 Mbps High Capacity service and requires the customer signal at the channel interface to conform to Bipolar with Eight Zero Substitution (B8ZS) line code format as described in the appropriate Technical Reference for High Capacity Service. Customer equipment must be compatible with this method of providing the unconstrained signal.

(4) Extended Superframe Format

Extended Superframe Format is an optional feature that passes a customer provided framing format for 1.544 Mbps High Capacity Service. Extended Superframe Format extends the customer's 1.544 Mbps framing structure from 12 to 24 frames and divides the 8 Kbps 193rd bit position into three distinct functionalities: 2 Kbps for frame synchronization, 2 Kbps for cyclic redundancy checking, and 4 Kbps used primarily to send performance monitoring information over the Facilities Data Link.

(5) (Reserved for Future Use)

(6) (Reserved for Future Use)

(7) (Reserved for Future Use)

SPECIAL ACCESS SERVICE

7.3 Service Descriptions, Rates and Charges (Cont'd)

7.3.10 High Capacity Service (Cont'd)

(F) Rates and Charges (Cont'd)

Each rate element is shown with its associated USOC, where appropriate.

(1) <u>Channel Termination</u> (TMECS)	<u>Monthly</u> <u>Fixed</u>	<u>Rate</u> <u>Per Mile</u>	<u>Nonrecurring</u> <u>Charge</u>
Per point of termination			
1.544 Mbps	\$ 207.00		\$ 645.00
1.544 Mbps {1}	275.27		645.00
44.736 Mbps (TWT++)	ICB		ICB
(2) <u>Channel Mileage</u>			
64 kbps {2}			
<u>Mileage Bands</u> (1L5TC)			
0 miles	7.61	0.00	
Over 0 to 4	7.61	2.97	
Over 4 to 8	9.27	2.57	
Over 8 to 25	9.27	2.57	
Over 25 to 50	17.16	2.24	
Over 50	20.90	2.17	
1.544 Mbps			
<u>Mileage Bands</u> (1L5XX)			
0 miles	0.00	0.00	
Over 0	71.00	45.00	
1.544 Mbps {1}			
<u>Mileage Bands</u>			
0 miles	0.00	0.00	
Over 0 to 4	122.44	51.50	
Over 4 to 8	122.44	51.50	
Over 8 to 25	178.52	44.48	
Over 25 to 50	205.80	43.39	
Over 50	205.80	43.39	
44.736 Mbps (1LO++)			
<u>Mileage Bands</u>			
0 miles	0.00	0.00	
Over 0 miles	ICB	ICB	

{1} Rate with service guarantee as indicated in 7.2.1(E).

{2} Effective June 30, 2021, this Service will no longer be available for purchase by new or existing customers. In addition, requests to move, add, change, or renew existing service arrangements will not be accepted. Following the expiration of a customer's existing term agreement, service will be provided on a month-to-month basis at the applicable Monthly rates until the service is discontinued. The Company currently plans to discontinue this service on or after June 30, 2024.

President - Texas
 AT&T Texas
 Dallas, Texas
 Issued: May 9, 2024
 Effective: May 10, 2024

ACCESS SERVICE TARIFF
 Section: 7
 Sheet: 77
 Revision: 4
 Replacing: 3

SPECIAL ACCESS SERVICE

7.3 Service Descriptions, Rates and Charges (Cont'd)

7.3.10 High Capacity Service (Cont'd)

(F) Rates and Charges (Cont'd)

(2) Channel Mileage (Cont'd)

	<u>Monthly Rate</u>	<u>Nonrecurring</u>
	<u>Fixed</u>	<u>Charge</u>
	<u>Per Mile</u>	
(3) (Reserved for Future Use)		
(4)		

(5) Multiplexing

Per arrangement

DS0 to Subrates {3}

Up to 20 2.4 kbps service (QSU24)	185.58	0.00
--------------------------------------	--------	------

Up to 10 4.8 kbps service (QSU48)	361.52	0.00
--------------------------------------	--------	------

Up to 5 9.6 kbps service (QSU96)	702.74	0.00
-------------------------------------	--------	------

DS1 to DS0 (QMU)	232.80	0.00
------------------	--------	------

DS1 to Voice {2} (MQ1)	232.80	0.00
---------------------------	--------	------

DS3 to DS1 (MXB++) Per arrangement	ICB	0.00
--	-----	------

{1} An additional Channel Termination charge will apply whenever the spare line is provided as a leg to the customer premises.

{2} A channel of this DS1 to the hub can be used for Digital Data Service.

{3} Effective June 30, 2021, this Service will no longer be available for purchase by new or existing customers. In addition, requests to move, add, change, or renew existing service arrangements will not be accepted. Following the expiration of a customer's existing term agreement, service will be provided on a month-to-month basis at the applicable Monthly rates until the service is discontinued. The Company currently plans to discontinue this service on or after June 30, 2024.

President - Texas
AT&T Texas
Dallas, Texas
Issued: May 9, 2024
Effective: May 10, 2024

ACCESS SERVICE TARIFF
Section: 7
Sheet: 78
Revision: 3
Replacing: 2

SPECIAL ACCESS SERVICE

7.3 Service Descriptions, Rates and Charges (Cont'd)

7.3.10 High Capacity Service (Cont'd)

(F) Rates and Charges (Cont'd)

	<u>Monthly Rate</u>		<u>Nonrecurring Charge</u>	
	<u>Fixed</u>	<u>Per Mile</u>	<u>Initial</u>	<u>Subsequent</u>
(6) <u>Clear Channel Capability (CLR)</u>				
Per channel termination	\$30.00		\$108.00	\$170.00
(7) <u>Extended Superframe Format (SF1)</u>				
Per channel termination	0.00		0.00	0.00
(8) (Reserved for Future Use)				
(9) (Reserved for Future Use)				
(10) (Reserved for Future Use)				
(11) (Reserved for Future Use)				

SPECIAL ACCESS SERVICE

7.3 Service Descriptions Rates and Charges (Cont'd)

7.3.10 High Capacity Service (Cont'd)

(F) Rates and Charges (Cont'd)

(12) High Capacity Term Pricing Plan (HC-TPP)

Rates effective: 03/04/96 ⁽¹⁾

(a) <u>Channel Termination</u> (TMECS)	3 Year ⁽³⁾ Monthly Rate		5 Year ⁽²⁾ Monthly Rate	
	Fixed	Per Mile	Fixed	Per Mile
Per point of termination				
1.544 Mbps	\$175.00		\$165.00	
(b) <u>Channel Mileage</u> (1L5XX)				
1.544 Mbps				
0 miles	\$ 0.00	\$ 0.00	\$ 0.00	\$ 0.00
Over 0 miles	60.00	22.00	57.00	18.00
(c) <u>Multiplexing</u>				
Per arrangement				
DS1 to DSO (QMU)	\$200.00		\$185.00	
DS1 to Voice (MQ1)	\$200.00		\$185.00	

(1) These rates are effective March 4, 1996 pursuant to PURA 95 Sec. 3.356 and SWBT's notification thereunder.

(2) Effective on February 16, 2019, High Capacity Term Pricing Plans are no longer available for 5 year term lengths, including for any otherwise available renewals, extensions or conversions.

(3) Effective November 1, 2022, High Capacity Term Pricing Plans for 3-year term lengths are no longer available, including conversions. Existing Term Plan Services, as of November 1, 2022, will continue to be provided under the then-current terms, for the remainder of the applicable term.

President - Texas
AT&T Texas
Dallas, Texas
Issued: May 9, 2024
Effective: May 10, 2024

ACCESS SERVICE TARIFF
Section: 7
Sheet: 78.2
Revision: 3
Replacing: 2

SPECIAL ACCESS SERVICE

7.3 Service Descriptions, Rates and Charges (Cont'd)

(This section is intentionally left blank)

President - Texas
AT&T Texas
Dallas, Texas
Issued: May 9, 2024
Effective: May 10, 2024

ACCESS SERVICE TARIFF
Section: 7
Sheet: 78.3
Revision: 2
Replacing: 1

SPECIAL ACCESS SERVICE

7.3 Service Descriptions, Rates and Charges (Cont'd)

(This section is intentionally left blank)

SPECIAL ACCESS SERVICE

7.4 Miscellaneous Rates and Charges

(A) Rollover

A Nonrecurring Charge(s) will apply when a customer requests a Rollover of Special Access Service as described in 7.2.7(A)(1) (Rollover). The Nonrecurring Charge(s) is applied on a first and additional basis, per Access Order, as specified below.

	<u>Nonrecurring Charge</u>	
	<u>First</u>	<u>Additional</u>
	<u>Circuit</u>	<u>Circuit</u>
- Analog*/Digital Link ⁽²⁾ to 1.544 Mbps High Capacity (DS1) - per service rolled over (NRBRA)	\$ 145.00	\$ 110.00
- 1.544 Mbps High Capacity (DS1) to 1.544 Mbps High Capacity (DS1) - per service rolled over (NRBRH)	160.00	120.00
- 1.544 Mbps High Capacity (DS1) to 44.736 Mbps High Capacity (DS3) - per service rolled over (NRBR1)	160.00	120.00

(B) Special Access Surcharge
(S25)

<u>Monthly</u>	<u>Nonrecurring Charge</u>	
<u>Rate</u>	<u>First</u>	<u>Additional</u>
	<u>Circuit</u>	<u>Circuit</u>

Per equivalent voice grade channel \$ 25.00

(C) Message Station Equipment
Recovery Charge (UTM)
Per Special Access Surcharge assessed

7.29

(D) Access Order Charge

See Section 5.4

(E) Service Rearrangement Charge
(NRBAC)

- Per circuit ⁽¹⁾ on the same Access Order for one or any combination of the following changes:	\$ 9.00	\$ 5.00
- Access Carrier Name Abbreviation (ACNA)		
- Customer Carrier Name Abbreviation (CCNA)		
- Billing Account Number (BNA)		
- Customer Circuit ID (CKR)		

* Analog Services include: Metallic Service⁽²⁾, Telegraph Service⁽²⁾ or Voice Grade Service⁽²⁾.

- (1) Each leg of a multipoint service will be treated as a separate circuit and charges applied as described in 7.2.4(D).
- (2) Effective June 30, 2021, this Service will no longer be available for purchase by new or existing customers. In addition, requests to move, add, change, or renew existing service arrangements will not be accepted. Following the expiration of a customer's existing term agreement, service will be provided on a month-to-month basis at the applicable Monthly rates until the service is discontinued. The Company currently plans to discontinue this service on or after June 30, 2024.

President - Texas
AT&T Texas
Dallas, Texas
Issued: May 9, 2024
Effective: May 10, 2024

ACCESS SERVICE TARIFF
Section: 7
Sheet: 80
Revision: 1
Replacing: Original

SPECIAL ACCESS SERVICE

7.5 (Reserved for Future Use)