

TARIFF DISTRIBUTION

FILE PACKAGE NO.: SC-21-0043

DATE: August 17, 2021

STATE: SOUTH CAROLINA

EFFECTIVE DATE: 06/30/2021

TYPE OF DISTRIBUTION: Approved

PURPOSE: Grandfather Metallic, Telegraph, Voice Grade, WATS, Digital Link,
and Derived Data Services effective 6/30/21 with targeted sunset
6/30/24.

<u>TARIFF SECTION</u>	<u>PAGE NUMBER</u>	<u>PAGE REVISION</u>
E007	1	0015
E007	2	0007
E007	4	0005
E007	5	0005
E007	6	0011
E007	7	0011
E007	8	0007
E007	9	0003
E007	10	0003
E007	10.1	0003
E007	11	0004
E007	12	0003
E007	13	0003
E007	14	0005
E007	15	0005
E007	16	0003
E007	17	0004
E007	18	0006
E007	19	0008
E007	19.0.1	0003
E007	19.1	0003
E007	20	0007
E007	21	0009
E007	21.1	0011
E007	21.3	0007
E007	22	0009
E007	22.1	0003
E007	23	0006
E007	23.1	0004

E007	25	0006
E007	27	0016
E007	27.1	0011
E007	28	0015
E007	29	0013
E007	32	0007
E007	33	0011
E007	33.0.1	0002
E007	33.4	0005
E007	33.5	0006
E007	34	0006
E007	35	0007
E007	36	0006
E007	37	0007
E007	38	0009
E007	38.1	0004
E007	39	0007
E007	41	0008
E007	41.1	0004
E007	42	0011
E007	42.1	0008
E007	45	0010
E007	45.1	0008
E007	45.2	0007
E007	46.2	0006

BELLSOUTH
TELECOMMUNICATIONS
SOUTH CAROLINA
ISSUED: June 15, 2021
BY: President - South Carolina
Columbia, South Carolina

ACCESS SERVICES TARIFF

Fifteenth Revised Page 1
Cancels Fourteenth Revised Page 1

EFFECTIVE: June 30, 2021

E7. SPECIAL ACCESS (A.K.A. BELLSOUTH SPA) SERVICE**E7.1 General**

Special Access (a.k.a. BellSouth SPA) service provides a transmission path to connect customer designated premises¹, either directly or through a Company hub where bridging or multiplexing functions are performed. Special Access (a.k.a. BellSouth SPA) service² includes all exchange access not utilizing Company end office switches.

The connections provided by Special Access (a.k.a. BellSouth SPA) service can be either analog or digital. Analog connections are differentiated by spectrum and bandwidth. Digital connections are differentiated by bit rate.

E7.1.1 Channel Types

- A. There are eight types of channels used to provide Special Access (a.k.a. BellSouth SPA) services. Each type has its own characteristics. All are subdivided by one or more of the following:
- Transmission specifications
 - Bandwidth
 - Speed (i.e., bit rate)
 - Spectrum
- B. Customers can order a basic channel and select from a list of available transmission parameters and channel interfaces, those that they desire to meet specific communications requirements.
- C. For purposes of ordering channels, each has been identified as a type of Special Access (a.k.a. BellSouth SPA) service. However, such identification is not intended to limit a customer's use of the channel nor to imply that the channel is limited to a particular use. For example, if a customer's equipment is capable of transmitting voice over a channel that is identified as Metallic⁴ (a.k.a. BellSouth SPA Metallic) service in this Tariff, there is no restriction against doing so. (C)
- D. Following is a brief description of each type of channel:
1. Telegraph⁴ (a.k.a. BellSouth SPA Telegraph) Grade - a channel for the transmission of binary signals at rates of 0 to 75 baud or 0 to 150 baud. (C)
 2. Voice Grade⁴ (a.k.a. BellSouth SPA DS0 VG) - a channel for the transmission of analog signals within an approximate bandwidth of 300-3000 Hz. (C)
 3. WATS Access Line⁴ (a.k.a. BellSouth SPA WATS Line) (WAL) - a channel from a customer designated premises to a WATS serving office for 800, WATS or similar service. (C)
 4. Wired Music³ - a channel for the transmission of audio signals. The nominal frequency bandwidths are from 200 to 3500 Hz, from 100 to 5000 Hz or from 50 to 8000 Hz.
 5. **(DELETED)**
 6. Digital Data Access⁴ (a.k.a. BellSouth SPA DS0 Digital Data) - a channel for the digital transmission of synchronous serial data at rates of 2.4, 4.8, 9.6, 19.2, 56.0 or 64.0 Kbps. (C)
 7. High Capacity (a.k.a. BellSouth SPA High Capacity) - a channel for the transmission of isochronous serial digital data at rates of 1.544, 3.152, 6.312, or 44.736 Mbps.
 8. Derived Data Channel⁴ (a.k.a. BellSouth SPA Derived Data Channel) - a digital data channel derived from a two-wire local exchange facility that transmits voice and data signals simultaneously. (C)

Note 1: Company provided Centrex Type Services systems and Answering Service Concentrators are considered to be customer premises for purposes of administering regulations and rates contained in this Tariff.

Note 2: For purposes of administering the surcharge regulations, WATS (a.k.a. BellSouth SPA WATS Line) access lines are considered to be Special Access (a.k.a. BellSouth SPA) service.

Note 3: Effective December 1, 2020, this Service will no longer be available for purchase by new or existing customers, and service agreements may no longer be renewed. In addition, requests to move, add, or change existing service arrangements will not be accepted. Following the expiration of a customer's existing term agreement, service will be provided on a month-to-month basis at the applicable month-to-month rates until the service is discontinued. AT&T currently plans to discontinue this Service on or after December 1, 2021.

Note 4: Effective June 30, 2021, this Service will no longer be available for purchase by new or existing customers. In addition, requests to move, add, change, or renew existing service arrangements will not be accepted. Following the expiration of a customer's existing term agreement, service will be provided on a month-to-month basis at the applicable Monthly rates until the service is discontinued. The Company currently plans to discontinue this service on or after June 30, 2024.

(N)
|
(N)

BELLSOUTH
 TELECOMMUNICATIONS
 SOUTH CAROLINA
 ISSUED: June 15, 2021
 BY: President - South Carolina
 Columbia, South Carolina

ACCESS SERVICES TARIFF

Seventh Revised Page 2
 Cancels Sixth Revised Page 2

EFFECTIVE: June 30, 2021

E7. SPECIAL ACCESS (A.K.A. BELLSOUTH SPA) SERVICE**E7.1 General (Cont'd)****E7.1.1 Channel Types (Cont'd)**

- E. Detailed descriptions of each of the channel types are provided in E7.2 following.
1. The customer also has the option of ordering digital high capacity facilities (i.e., 1.544 Mbps, 3.152 Mbps, 6.312 Mbps, and 44.736 Mbps) to a Company Hub for channelization to individual channels of a lower capacity. Descriptions of the types of channelization available at the hubs, as well as the number of individual channels which may be derived from each type of facility are set forth in E7.2 following. Additionally, the customer may specify optional features for the individual channels derived from the facility to further tailor the channel to meet specific communications requirements. Descriptions of the optional features and functions available are also set forth in E7.2 following.
 2. For example, a customer may order a 44.736 Mbps facility from a customer designated premises to a Company Hub for channelization to twenty-eight 1.544 Mbps channels. The 1.544 Mbps channels may be further channelized at the same or a different Hub to Voice Grade¹ (a.k.a. BellSouth SPA DS0 VG) channels or may be extended to other customer designated premises. Optional features may be added to either the 1.544 Mbps or the Voice Grade¹ (a.k.a. BellSouth SPA DS0 VG) channels. (C)

E7.1.2 Rate Categories

- A. There are *four* basic rate categories which apply to Special Access (a.k.a. BellSouth SPA) service:
1. Local Channels (described in B. following)
 2. Interoffice Channel (described in C. following)
 3. Optional Features and Functions (described in D. following)
 4. Self-healing Multi-nodal Alternate Route Topology Ring (SMARTRing[®] service [a.k.a. BellSouth Dedicated Ring]) (described in F. following)
- B. Local Channel
- The Local Channel rate category provides for the communications path between the demarcation point at a customer designated premises and the serving wire center of that premises. Included as part of the Local Channel is a standard channel interface arrangement which defines the technical characteristics associated with the type of facilities to which the access service is to be connected at the Point of Termination (POT) and the type of signaling capability, if any. The signaling capability itself is provided as an optional feature as set forth in C. following. One Local Channel charge applies per customer designated premises at which the channel is terminated. This charge will apply even if the customer premises and the serving wire center are co-located in a Company building.
- C. Interoffice Channel
- The Interoffice Channel rate category provides for the transmission facilities between the serving wire centers associated with two customer designated premises, between a serving wire center associated with a customer designated premises and a Company Hub or between two Company Hubs. Interoffice Channel mileage is portrayed in mileage bands. There are two rates that apply for each band, i.e., a flat rate per band and a rate per mile.
- D. Optional Features and Functions
- The Optional Features and Functions rate category provides for optional features and functions which may be added to a Special Access (a.k.a. BellSouth SPA) service to improve its quality or utility to meet specific communications requirements. These are not necessarily identifiable with specific equipment, but rather represent the end result in terms of performance characteristics which may be obtained. These characteristics may be obtained by using various combinations of equipment. Although the equipment necessary to perform a specified function may be installed at various locations along the path of the service, they will be charged for as a single rate element.

Note 1: Effective June 30, 2021, this Service will no longer be available for purchase by new or existing customers. In addition, requests to move, add, change, or renew existing service arrangements will not be accepted. Following the expiration of a customer's existing term agreement, service will be provided on a month-to-month basis at the applicable Monthly rates until the service is discontinued. The Company currently plans to discontinue this service on or after June 30, 2024.

(N)
 |
 (N)

BELLSOUTH
TELECOMMUNICATIONS
SOUTH CAROLINA
ISSUED: June 15, 2021
BY: President - South Carolina
Columbia, South Carolina

ACCESS SERVICES TARIFF

Fifth Revised Page 4
Cancels Fourth Revised Page 4

EFFECTIVE: June 30, 2021

E7. SPECIAL ACCESS (A.K.A. BELLSOUTH SPA) SERVICE**E7.1 General (Cont'd)****E7.1.3 Service Configurations**

There are two types of service configurations over which Special Access (a.k.a. BellSouth SPA) services are provided: two-point service, multipoint service and *SMARTRing service (a.k.a. BellSouth Dedicated Ring)*.

A. Two-Point Service

A two-point service connects two customer designated premises, either on a directly connected basis or through a hub where channelization functions are performed.

Applicable rate elements are:

- Local Channels
- Interoffice Channels (as applicable)
- Optional Features and Functions (when applicable)

In addition, a Special Access (a.k.a. BellSouth SPA) Surcharge as set forth in E7.4.2 following and a Message Station Equipment Recovery Charge as set forth in E7.4.3 following may be applicable.

The following diagram depicts a two-point Voice Grade¹ (a.k.a. BellSouth SPA DS0 VG) service connecting two customer designated premises located fifteen miles apart. The service is provided with C-Type Conditioning. (C)

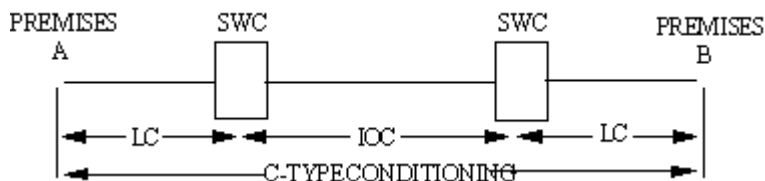

LC - Local Channel

IOC - Interoffice Channel

SWC - Serving Wire Center

1. Applicable rate elements are:
 - a. Local Channels (two applicable)
 - b. Interoffice Channels (mileage band over nine thru twenty-five miles)
 - c. C-Type conditioning Optional Feature

B. Multipoint Service

Multipoint service connects three or more customer designated premises through a Company Hub. There is no limitation on the number of mid-links available with multipoint service. However, when more than three mid-links are provided in tandem, the quality of the service may be degraded. A mid-link is a channel between hubs (i.e., bridging locations). Only certain types of Special Access (a.k.a. BellSouth SPA) service are provided as multipoint service. These are so designated in the Service Descriptions set forth in E7.2. following.

When ordering, the customer will specify the desired bridging Hub(s) selected from the Exchange Carrier Association Tariff F.C.C. No. 4. This tariff identifies the type(s) of bridging functions which are available and the serving wire centers at which they are available.

1. Applicable Rate Elements are:
 - a. Local Channels (one per customer designated premises)
 - b. Interoffice Channels (as applicable between each designated customer premises and the Hub and between Hubs)
 - c. Bridging
 - d. Additional Optional Features (when applicable)

In addition, a Special Access (a.k.a. BellSouth SPA) Surcharge as set forth in E7.4.2. following and a Message Station Equipment Recovery Charge as set forth in E7.4.3. following may be applicable.

Note 1: Effective June 30, 2021, this Service will no longer be available for purchase by new or existing customers. In addition, requests to move, add, change, or renew existing service arrangements will not be accepted. Following the expiration of a customer's existing term agreement, service will be provided on a month-to-month basis at the applicable Monthly rates until the service is discontinued. The Company currently plans to discontinue this service on or after June 30, 2024.

(N)
|
(N)

E7. SPECIAL ACCESS (A.K.A. BELLSOUTH SPA) SERVICE

E7.1 General (Cont'd)

E7.1.3 Service Configurations (Cont'd)

B. Multipoint Service (Cont'd)

Example: Voice Grade¹ (a.k.a. BellSouth SPA DS0 VG) multipoint connecting four customer premises via two customer specified bridging hubs. (C)

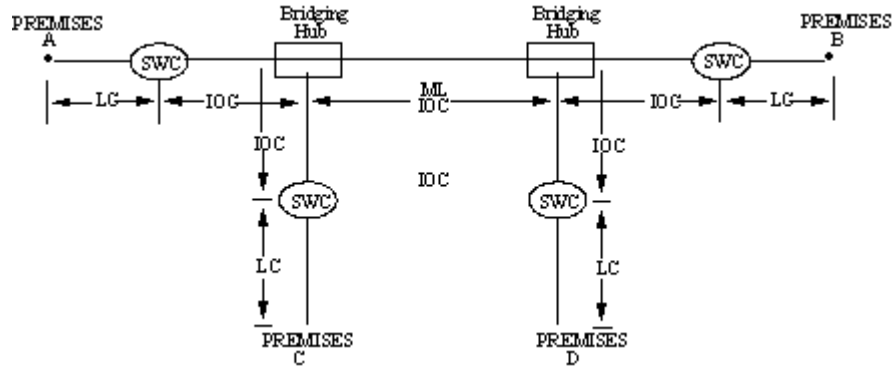

- LC - Local Channel
- IOC - Interoffice Channel
- B - Bridging
- SWC - Serving Wire Center

2. Applicable rate elements are:
 - a. Local Channels (four applicable)
 - b. Interoffice Channel (five sections, each from appropriate mileage band)
 - c. Bridging Optional Feature (six applicable, i.e., each bridge port)

Note 1: Effective June 30, 2021, this Service will no longer be available for purchase by new or existing customers. In addition, requests to move, add, change, or renew existing service arrangements will not be accepted. Following the expiration of a customer's existing term agreement, service will be provided on a month-to-month basis at the applicable Monthly rates until the service is discontinued. The Company currently plans to discontinue this service on or after June 30, 2024.

(N)
 |
 (N)

BELLSOUTH
 TELECOMMUNICATIONS
 SOUTH CAROLINA
 ISSUED: June 15, 2021
 BY: President - South Carolina
 Columbia, South Carolina

ACCESS SERVICES TARIFF

Eleventh Revised Page 6
 Cancels Tenth Revised Page 6

EFFECTIVE: June 30, 2021

E7. SPECIAL ACCESS (A.K.A. BELLSOUTH SPA) SERVICE**E7.1 General (Cont'd)****E7.1.4 Alternate Use**

- A. Alternate Use occurs when a service is arranged by the Company so that the customer can select different types of transmission at different times. A customer may use a service in any privately beneficial manner. However, where technical or engineering changes are required to effectuate an alternative use, the Company will make such special arrangements available on an individual case basis.
- B. The arrangement required to transfer the service from one operation to the other (i.e., the transfer relay and control leads) will be rated and provided on an individual case basis and filed in Section E12., Specialized Service or Arrangements. The customer will pay the stated tariff rates for the Access Service rate elements for the service ordered (i.e., Local Channels, Interoffice Channels as applicable, and Optional Features and Functions, if any.)

E7.1.5 Special Facilities Routing

A customer may request that the facilities used to provide Special Access (a.k.a. BellSouth SPA) service be specially routed. The regulations, rates and charges for Special Facilities Routing (i.e., Avoidance, Diversity and Cable Only) are as set forth in Section E11. following.

E7.1.6 Design Layout Report

At the request of the customer, the Company will provide to the customer the make-up of the facilities and services provided in this section of the Tariff as Special Access (a.k.a. BellSouth SPA) service to aid the customer in designing its overall service. This information will be provided in the form of a Design Layout Report.

The Design Layout Report will be provided to the customer at no charge, and will be reissued or updated whenever these facilities are materially changed.

E7.1.7 Acceptance Testing

- A. At no additional charge, the Company will, at the customer's request, cooperatively test, at the time of installation, the following parameters:
 1. For Voice Grade² (a.k.a. BellSouth SPA DS0 VG) services, acceptance tests will include tests for loss, 3-tone slope, DC continuity, operational signaling, C-notched noise and C-message noise when these parameters are applicable and specified in the order for service. Additionally, for Voice Grade² (a.k.a. BellSouth SPA DS0 VG) services, a balance (improved loss) test will be made if the customer has ordered the improved loss optional feature. (C)
 2. For other analog services (i.e., Telegraph² (a.k.a. BellSouth SPA Telegraph), WATS Access Line² (a.k.a. BellSouth SPA WATS Line) and Wired Music⁽¹⁾ and for digital services (i.e., Digital Data Access² (a.k.a. BellSouth SPA DS0 Digital Data), WATS Access Line² (a.k.a. BellSouth SPA WATS Line) and High Capacity (a.k.a. BellSouth SPA High Capacity)), acceptance tests will include tests for the parameters applicable to the service as specified in the order for service. (C)
- B. In addition to the above tests, Additional Cooperative Acceptance Testing for Voice Grade² (a.k.a. BellSouth SPA DS0 VG) service to test other parameters, as described in E13.3.5.B. following, is available at the customer's request. All test results will be made available to the customer upon request. (C)

E7.1.8 Ordering Options and Conditions

- A. The ordering option available to the customer in the provision of Special Access (a.k.a. BellSouth SPA) service is the Access Order.
- B. This option is set forth in detail in Section E5. preceding. Also included in that section are other charges which may be associated with ordering Special Access (a.k.a. BellSouth SPA) service (e.g., Service Date Change Charges, Cancellation Charges, etc.).

Note 1: Effective December 1, 2020, this Service will no longer be available for purchase by new or existing customers, and service agreements may no longer be renewed. In addition, requests to move, add, or change existing service arrangements will not be accepted. Following the expiration of a customer's existing term agreement, service will be provided on a month-to-month basis at the applicable month-to-month rates until the service is discontinued. AT&T currently plans to discontinue this Service on or after December 1, 2021.

Note 2: Effective June 30, 2021, this Service will no longer be available for purchase by new or existing customers. In addition, requests to move, add, change, or renew existing service arrangements will not be accepted. Following the expiration of a customer's existing term agreement, service will be provided on a month-to-month basis at the applicable Monthly rates until the service is discontinued. The Company currently plans to discontinue this service on or after June 30, 2024.

(N)
 |
 (N)

BELLSOUTH
 TELECOMMUNICATIONS
 SOUTH CAROLINA
 ISSUED: June 15, 2021
 BY: President - South Carolina
 Columbia, South Carolina

ACCESS SERVICES TARIFF

Eleventh Revised Page 7
 Cancels Tenth Revised Page 7

EFFECTIVE: June 30, 2021

E7. SPECIAL ACCESS (A.K.A. BELLSOUTH SPA) SERVICE

E7.1 General (Cont'd)

E7.1.8 Ordering Options And Conditions (Cont'd)

- C. For the purposes of ordering, there are nine categories of Special Access (a.k.a. BellSouth SPA) service. These are:
 - 1. Telegraph Grade² (a.k.a. BellSouth SPA Telegraph) (TG) (C)
 - 2. Voice Grade² (a.k.a. BellSouth SPA DSO VG) (VG) (C)
 - 3. Wired Music⁽¹⁾ (AP)
 - 4. Commercial Quality Video (a.k.a. BellSouth SPA Commercial Quality Video) (TV)
 - 5. Digital Data Access² (a.k.a. BellSouth SPA DSO Digital Data) service (DDAS) (C)
 - 6. High Capacity (a.k.a. BellSouth SPA High Capacity) (HC)
 - 7. WATS Access Line² (a.k.a. BellSouth SPA WATS Line) (WAL) (C)
 - 8. Derived Data Channel² (a.k.a. BellSouth SPA Derived Data Channel) service (C)
 - 9. Self-Healing Rings (SMARTRing service [a.k.a. BellSouth Dedicated Ring])
- D. Each service consists of a basic channel to which a predefined technical specifications package, channel interface(s) and, when desired, optional features and functions are added to construct the service desired by the customer. Each of the components of the service is described in this section. Terms and conditions for **Central Office** interconnection of collocator-provided transmission equipment are set forth in BellSouth Telecommunications, Inc., Tariff F.C.C. No. 1, Section 20. **Terms, conditions, and rates for Physical Access Collocation Cross-Connects and Virtual Access Collocation Cross-Connects are set forth in Section E13. of this Tariff for those services that are permitted to connect directly to a carrier's collocation space.**
- E. The channel description specifies the characteristics of the basic channel and indicates whether the channel is provided between customer designated premises or between a customer designated premises and a Company hub where bridging and/or channelization functions are performed.
- F. Information pertaining to the technical specifications packages indicates the transmission parameters that are available with each package. This information is displayed in a matrix with the transmission parameters listed down the left side and the packages listed across the top. Each package is identified by a code, e.g., VG1. The first two letters of the code indicate the category of Special Access (a.k.a. BellSouth SPA) service to which the parameters are applicable. These two-letter codes are shown above in parentheses following the category of Special Access (a.k.a. BellSouth SPA) service. The number "1" following the two-letter code indicates the technical specifications package for a voice grade² service. An alphanumeric designation following the two letter code indicates the specific predefined package. When appropriate, the Technical Reference which contains detailed specifications for the parameters is shown following the matrix. (C)
- G. Channel interfaces at each point of termination on a two-point service may be symmetrical or asymmetrical. On a multipoint service they may also be symmetrical or asymmetrical. However, communications can only be provided between points of termination with compatible channel interfaces. Only certain channel interfaces are compatible. These are set forth in a combination format.
 Only certain channel interface combinations are available with the predefined technical specifications packages. These are delineated in the Technical References set forth at the end of this E7.2.
- H. The optional features and functions available with each type of Special Access (a.k.a. BellSouth SPA) service are described in this section. The optional features and functions information also indicates with which technical specifications packages they are available. Such information is displayed in a matrix with the optional feature or function listed down the left side and the technical specifications package listed across the top.
- I. The Company will maintain existing transmission specifications on services installed prior to the effective date of this Tariff, except that the existing services with performance specifications exceeding the standard listed in this provision will be maintained at the performance levels specified in this Tariff.
 All services installed will conform to the transmission specification standards contained in this section of the Tariff or in the following Technical References for each category of service:

Telegraph Grade ² (a.k.a. BellSouth SPA Telegraph)	TR-NPL-000336	(C)
Voice Grade ² (a.k.a. BellSouth SPA DSO VG)	TR-NPL-000335	(C)
	PUB 41004, Table 4	
Wired Music ⁽¹⁾	TR-NPL-000337	
Commercial Quality Video (a.k.a. BellSouth SPA Commercial Quality Video)	BellSouth TR-73557	

Note 1: Effective December 1, 2020, this Service will no longer be available for purchase by new or existing customers, and service agreements may no longer be renewed. In addition, requests to move, add, or change existing service arrangements will not be accepted. Following the expiration of a customer's existing term agreement, service will be provided on a month-to-month basis at the applicable month-to-month rates until the service is discontinued. AT&T currently plans to discontinue this Service on or after December 1, 2021.

Note 2: Effective June 30, 2021, this Service will no longer be available for purchase by new or existing customers. In addition, requests to move, add, change, or renew existing service arrangements will not be accepted. Following the expiration of a customer's existing term agreement, service will be provided on a month-to-month basis at the applicable Monthly rates until the service is discontinued. The Company currently plans to discontinue this service on or after June 30, 2024. (N)

BELLSOUTH
 TELECOMMUNICATIONS
 SOUTH CAROLINA
 ISSUED: June 15, 2021
 BY: President - South Carolina
 Columbia, South Carolina

ACCESS SERVICES TARIFF

Seventh Revised Page 8
 Cancels Sixth Revised Page 8

EFFECTIVE: June 30, 2021

E7. SPECIAL ACCESS (A.K.A. BELLSOUTH SPA) SERVICE

E7.1 General (Cont'd)

E7.1.8 Ordering Options And Conditions (Cont'd)

I. (Cont'd)

Digital Data Access ¹ (<i>a.k.a. BellSouth DSO Digital Data</i>)	TR-NPL-000341	(C)
For 2.4, 4.8, 9.6 and 56.0 Kbps	BellCore PUB 62310	
For 19.2 Kbps	INC. BULLETIN CB-INC-100	
For 64.0 Kbps	AT&T PUB 62310	
High Capacity (<i>a.k.a. BellSouth SPA High Capacity</i>)	TA-TSY-000342 TR-NPL-000054	
WATS Access Line ¹ (<i>a.k.a. BellSouth SPA WATS Line</i>)	TR-NPL-000334	(C)
Derived Data Channel ¹ (<i>a.k.a. BellSouth Derived Data Channel</i>) service	BellSouth TR-73548	(C)
	BellSouth TR-73548, Addendum 1	

E7.2 Service Descriptions

E7.2.1 Reserved for Future Use

Note 1: Effective June 30, 2021, this Service will no longer be available for purchase by new or existing customers. In addition, requests to move, add, change, or renew existing service arrangements will not be accepted. Following the expiration of a customer's existing term agreement, service will be provided on a month-to-month basis at the applicable Monthly rates until the service is discontinued. The Company currently plans to discontinue this service on or after June 30, 2024.

(N)
 |
 (N)

BELLSOUTH
 TELECOMMUNICATIONS
 SOUTH CAROLINA
 ISSUED: June 15, 2021
 BY: President - South Carolina
 Columbia, South Carolina

ACCESS SERVICES TARIFF

Third Revised Page 9
 Cancels Second Revised Page 9

EFFECTIVE: June 30, 2021

E7. SPECIAL ACCESS (A.K.A. BELLSOUTH SPA) SERVICE

E7.2 Service Descriptions (Cont'd)

E7.2.2 Telegraph Grade¹ (a.k.a. BellSouth SPA Telegraph) Service

(C)

A. Basic Channel Description

A Telegraph Grade (*a.k.a. BellSouth SPA Telegraph*) channel is an unconditioned channel capable of transmitting binary signals at rates of 0-75 baud or 0-150 baud. This channel is furnished for half-duplex or duplex operation. Telegraph Grade (*a.k.a. BellSouth SPA Telegraph*) channels are provided between customer designated premises or between a customer designated premises and a Company Hub. Telegraph Grade (*a.k.a. BellSouth SPA Telegraph*) service is not available for additions, new installations or moves of service.

B. Technical Specifications Packages

Parameter	Package TG-	
	1	2
Telegraph Distortion	X	X

The technical specifications are delineated in Technical Reference TR-NPL-000336.

C. Channel Interfaces

Compatible channel interfaces are set forth in Technical Reference TR-NPL-000336.

D. Optional Features and Functions

1. Telegraph Bridging (two-wire and four-wire)

The following table shows the technical specifications packages with which the optional features and functions are available.

	Available with Technical Specifications Package TG-	
	1	2
Telegraph Bridging	X	X

E7.2.3 Voice Grade¹ (a.k.a. BellSouth SPA DS0 VG) Service

(C)

A. Basic Channel Description

A Voice Grade (*a.k.a. BellSouth SPA DS0 VG*) channel is a channel which provides voice frequency transmission capability in the nominal frequency range of 300 to 3000 Hz and may be terminated two-wire or four-wire. Voice Grade (*a.k.a. BellSouth SPA DS0 VG*) channels are provided between customer designated premises or between a customer designated premises and a Company Hub.

Voice Grade (*a.k.a. BellSouth SPA DS0 VG*) Channels are classified as Voice Grade/Voice or Voice Grade/Data depending on the suitability of the technical specification package requested by the customer. Voice Grade (*a.k.a. BellSouth SPA DS0 VG*) Technical Specification Packages 1, 2, 3, 4, 5, 7, 8, 9, 11 and 12 are suitable for Voice Grade/Voice. The Technical Specification Packages 6 and 10 are suitable for Voice Grade/Data Service.

B. Technical Specifications Packages

Note 1: Effective June 30, 2021, this Service will no longer be available for purchase by new or existing customers. In addition, requests to move, add, change, or renew existing service arrangements will not be accepted. Following the expiration of a customer's existing term agreement, service will be provided on a month-to-month basis at the applicable Monthly rates until the service is discontinued. The Company currently plans to discontinue this service on or after June 30, 2024.

(N)
 |
 (N)

BELLSOUTH
 TELECOMMUNICATIONS
 SOUTH CAROLINA
 ISSUED: June 15, 2021
 BY: President - South Carolina
 Columbia, South Carolina

ACCESS SERVICES TARIFF

Third Revised Page 10
 Cancels Second Revised Page 10

EFFECTIVE: June 30, 2021

E7. SPECIAL ACCESS (A.K.A. BELLSOUTH SPA) SERVICE

E7.2 Service Descriptions (Cont'd)

E7.2.3 Voice Grade¹ (a.k.a. BellSouth SPA DS0 VG) Service (Cont'd)

(C)

B. Technical Specifications Packages (Cont'd)

Parameter	Package VG-												
	1	2	3	4	5	6	7	8	9	10	11	12	
Attenuation Distortion	X	X	X	X	X	X	X	X	X	X	X	X	X
C-Message Noise	X	X	X	X	X	X	X	X	X	X	X	X	X
Echo Control	X	X	X		X		X	X			X	X	
Envelope Delay													
Distortion						X	X	X	X	X	X	X	X
Frequency Shift						X	X	X	X	X	X	X	X
Impulse Noise					X	X	X	X	X	X	X	X	X
Intermodulation													
Distortion						X	X	X	X	X	X	X	X
Loss Deviation	X	X	X	X	X	X	X	X	X	X	X	X	X
Phase Jitter						X	X	X	X	X	X	X	X
Signal-to-C Message Noise				X									
Signal-to-C Notch Noise					X	X	X	X	X	X	X	X	X

The technical specifications for these parameters are delineated in Technical Reference TR-NPL-000335 and associated Addendum.

C. Channel Interfaces

The following channel interfaces for Voice Grade (a.k.a. BellSouth SPA DS0 VG) service do not require signaling capability: DA, DB, DD, DE, DS, NO, PR and TF.

The following channel interfaces for Voice Grade (a.k.a. BellSouth SPA DS0 Digital Data) service require signaling capability: AB, AC, CT, DX, EA, EB, EC, EX, GO, GS, LA, LB, LC, LO, LR, LS, RV and SF.

Compatible channel interfaces are set forth in Technical Reference TR-NPL-A and Associated Addendum following.

Note 1: Effective June 30, 2021, this Service will no longer be available for purchase by new or existing customers. In addition, requests to move, add, change, or renew existing service arrangements will not be accepted. Following the expiration of a customer's existing term agreement, service will be provided on a month-to-month basis at the applicable Monthly rates until the service is discontinued. The Company currently plans to discontinue this service on or after June 30, 2024.

(N)
 |
 (N)

BELLSOUTH
 TELECOMMUNICATIONS
 SOUTH CAROLINA
 ISSUED: June 15, 2021
 BY: President - South Carolina
 Columbia, South Carolina

ACCESS SERVICES TARIFF

Third Revised Page 10.1
 Cancels Second Revised Page 10.1

EFFECTIVE: June 30, 2021

E7. SPECIAL ACCESS (A.K.A. BELLSOUTH SPA) SERVICE**E7.2 Service Descriptions (Cont'd)****E7.2.3 Voice Grade³ (a.k.a. BellSouth SPA DS0 VG) Service (Cont'd)**

(C)

D. Optional Features And Functions

1. Central Office Bridging
 - a. Voice Bridging¹ (two-wire and four-wire)
 - b. Data Bridging² (two-wire and four-wire)
 - c. Telephoto Bridging² (two-wire and four-wire)

Note 1: Voice Bridging is intended for use with VG2, 5 and 12. However, it may be used on VG6 and VG10 at a customer's request.

Note 2: Telephoto Bridging is intended for use on VG11.

Note 3: Effective June 30, 2021, this Service will no longer be available for purchase by new or existing customers. In addition, requests to move, add, change, or renew existing service arrangements will not be accepted. Following the expiration of a customer's existing term agreement, service will be provided on a month-to-month basis at the applicable Monthly rates until the service is discontinued. The Company currently plans to discontinue this service on or after June 30, 2024.

(N)

(N)

BELLSOUTH
TELECOMMUNICATIONS
SOUTH CAROLINA
ISSUED: June 15, 2021
BY: President - South Carolina
Columbia, South Carolina

ACCESS SERVICES TARIFF

Fourth Revised Page 11
Cancels Third Revised Page 11

EFFECTIVE: June 30, 2021

E7. SPECIAL ACCESS (A.K.A. BELLSOUTH SPA) SERVICE**E7.2 Service Descriptions (Cont'd)****E7.2.3 Voice Grade¹ (a.k.a. BellSouth SPA DS0 VG) Service (Cont'd)**

(C)

D. Optional Features And Functions (Cont'd)

1. Central Office Bridging (Cont'd)
2. Conditioning

Conditioning provides more specific transmission characteristics for Voice Grade (a.k.a. BellSouth SPA DS0 VG) services. C-Type conditioning controls attenuation distortion and envelope delay distortion. Sealing Current helps maintain continuity on dry metallic¹ loops.

(C)

For two-point services, the parameters apply to each service. For multipoint services, the parameters apply to each mid link or end link. C-Type conditioning and D-Conditioning may be combined on the same service.

a. C-Type Conditioning

C-Type Conditioning is provided for the additional control of attenuation distortion and envelope delay distortion on data services. The attenuation distortion and envelope delay distortion specifications for C-Type Conditioning are:

Attenuation Distortion (Frequency Response) Relative to 1004 Hz

Frequency Range (Hz)	Variation (dB)
504 - 2804	-1.0 to +3.0
304 - 3004	-2.0 to +6.0

Envelope Delay Distortion

Frequency Range (Hz)	Variation (micro-seconds)
1004 - 2604	Less than 501
604 - 2604	Less than 1501
504 - 2804	Less than 3001

b. Improved Attenuation Distortion

Improved attenuation distortion is provided for additional control of attenuation distortion. The improved attenuation distortion specifications are:

Attenuation Distortion (Frequency Response) Relative to 1004 Hz

Frequency Range (Hz)	Variation (dB)
404-2804	-1.0 to +2.0
304-3004	-1.0 to +3.0
3004-3204	-2.0 to +6.0

Note 1: Effective June 30, 2021, this Service will no longer be available for purchase by new or existing customers. In addition, requests to move, add, change, or renew existing service arrangements will not be accepted. Following the expiration of a customer's existing term agreement, service will be provided on a month-to-month basis at the applicable Monthly rates until the service is discontinued. The Company currently plans to discontinue this service on or after June 30, 2024.

(N)

(N)

BELLSOUTH
 TELECOMMUNICATIONS
 SOUTH CAROLINA
 ISSUED: June 15, 2021
 BY: President - South Carolina
 Columbia, South Carolina

ACCESS SERVICES TARIFF

Third Revised Page 12
 Cancels Second Revised Page 12

EFFECTIVE: June 30, 2021

E7. SPECIAL ACCESS (A.K.A. BELLSOUTH SPA) SERVICE

E7.2 Service Descriptions (Cont'd)

E7.2.3 Voice Grade¹ (a.k.a. BellSouth SPA DS0 VG) Service (Cont'd)

(C)

D. Optional Features And Functions (Cont'd)

2. Conditioning (Cont'd)

c. Improved Envelope Delay Distortion

Improved envelope delay distortion is provided for additional control of envelope distortion. The improved envelope delay distortion specifications are:

Envelope Delay Distortion

Frequency Range (Hz)	Variation (micro-seconds)
1001-2604	Less than 101
604-2604	Less than 301
504-2804	Less than 3001

d. Sealing Current Conditioning

Sealing Current Conditioning is provided to help maintain continuity on dry metallic¹ loops. It is usually associated with four-wire DA or NO type channel interfaces.

(C)

3. Customer Specified Premises Receive Level

This option allows the customer to specify the receive level at the Point of Termination. The level must be within a specific range of effective four-wire transmission. The ranges are delineated in Technical Reference TR-NPL-000335.

4. Echo Control

a. ELEPL 2 (Equal Level Echo Path Loss)

On Effective Two-Wire Transmission at Four-Wire Point of Termination (applicable to each two-wire port): Provides for a fixed 600 ohm impedance, variable level range and simplex reversal. Company equipment is required at the customer's premises where this option is ordered. Improved Return Loss parameters are delineated in Technical Reference TR-NPL-000335.

b. Improved Return Loss

On Effective Two-Wire Transmission at Two-Wire Point of Termination: Provides for more stringent Echo Control specifications. In order for this option to be applicable, the transmission path must be four-wire at one Point of Termination (POT) and two-wire at the other POT. Placement of Company equipment may be required at the customer's premises with two-wire POT. The Improved Return Loss parameters are delineated in Technical Reference TR-NPL-000335.

5. D-Conditioning

D-Conditioning provides transmission characteristics suitable for data communications. Specifically, D-Conditioning provides for the control of Signal to C-Notched Noise Ratio and intermodulation distortion. It is available for two-point services or multipoint services.

Note 1: Effective June 30, 2021, this Service will no longer be available for purchase by new or existing customers. In addition, requests to move, add, change, or renew existing service arrangements will not be accepted. Following the expiration of a customer's existing term agreement, service will be provided on a month-to-month basis at the applicable Monthly rates until the service is discontinued. The Company currently plans to discontinue this service on or after June 30, 2024.

(N)

(N)

BELLSOUTH
 TELECOMMUNICATIONS
 SOUTH CAROLINA
 ISSUED: June 15, 2021
 BY: President - South Carolina
 Columbia, South Carolina

ACCESS SERVICES TARIFF

Third Revised Page 13
 Cancels Second Revised Page 13

EFFECTIVE: June 30, 2021

E7. SPECIAL ACCESS (A.K.A. BELLSOUTH SPA) SERVICE**E7.2 Service Descriptions (Cont'd)****E7.2.3 Voice Grade¹ (a.k.a. BellSouth SPA DS0 VG) Service (Cont'd)**

(C)

D. Optional Features And Functions (Cont'd)

5. D-Conditioning (Cont'd)

The signal to C-Notched Noise Ratio and intermodulation distortion parameters for D-Conditioning are:

- Signal to C-Notched Noise Ratio is equal to or greater than 32dB
- Intermodulation distortion:
 - Signal to second order modulation products (R2) is equal to or greater than 38dB
 - Signal to third order modulation products (R3) is equal to or greater than 42dB

When a service equipped with D-Conditioning is used for voice communications, the quality of the voice transmission may not be satisfactory. D-Conditioning transmission characteristics are described in Technical Reference TR-NPL-000335 under the name Data Capability.

6. Telephoto Conditioning

Telephoto Conditioning provides transmission characteristics suitable for telephotographic communications. Specifically, Telephoto Conditioning is provided for the control of attenuation distortion and envelope delay distortion on telephotographic services. The attenuation distortion and envelope delay distortion parameters for Telephoto Conditioning are:

Attenuation Distortion
(1004 Hz Reference)

Frequency Range (Hz)	Variation (dB)
500 - 3000	- 0.5 to + 1.5
300 - 3200	- 1.0 to + 2.5

Envelope Delay Distortion

Frequency Range (Hz)	Variation (mcs)
1000 - 2600	Less than 111
800 - 2800	Less than 181

7. Signaling Capability

Signaling Capability provides for the process by which one customer premises alerts another customer premises on the same service with which it wishes to communicate.

Note 1: Effective June 30, 2021, this Service will no longer be available for purchase by new or existing customers. In addition, requests to move, add, change, or renew existing service arrangements will not be accepted. Following the expiration of a customer's existing term agreement, service will be provided on a month-to-month basis at the applicable Monthly rates until the service is discontinued. The Company currently plans to discontinue this service on or after June 30, 2024.

(N)

(N)

BELLSOUTH
 TELECOMMUNICATIONS
 SOUTH CAROLINA
 ISSUED: June 15, 2021
 BY: President - South Carolina
 Columbia, South Carolina

ACCESS SERVICES TARIFF

Fifth Revised Page 14
 Cancels Fourth Revised Page 14

EFFECTIVE: June 30, 2021

E7. SPECIAL ACCESS (A.K.A. BELLSOUTH SPA) SERVICE

E7.2 Service Descriptions (Cont'd)

E7.2.3 Voice Grade¹ (a.k.a. BellSouth SPA DS0 VG) Service (Cont'd)

(C)

D. Optional Features And Functions (Cont'd)

8. Improved Termination

The Improved Termination option provides a fixed 600 ohm impedance, a variable level range and simplex reversal, when applicable, at the point of termination. Company equipment is required at the customer's premises when this option is ordered. The Improved Termination parameters are delineated in Technical Reference TR-NPL-000335.

9. Simplex Reversal

The Simplex Reversal option physically turns over the simplex DC path presented at the four-wire point of termination when LO, LS, GO, GS, & DX signaling is provided at the point of termination.

10. FlexServ® service (a.k.a. BellSouth SPA Customer Reconfiguration)

FlexServ® service (a.k.a. BellSouth SPA Customer Reconfiguration) provides the customer the ability to monitor and reconfigure Voice Grade (a.k.a. BellSouth SPA DS0 VG) service provided by the Company. FlexServ® service (a.k.a. BellSouth SPA Customer Reconfiguration) is described in E7.4.12 following. Charges for this feature are contained in E7.5.16 following.

The following table shows the technical specifications packages with which the optional features and functions are available.

	Available with Technical Specifications Package VG-											
	1	2	3	4	5	6	7	8	9	10	11	12
C-Type Conditioning					X	X	X	X	X	X		
Improved Attenuation												
Distortion					X	X	X	X	X	X		
Improved Envelope												
Delay Distortion					X	X	X	X	X	X		
Central Office												
Bridging												
Capability			X		X	X				X	X	X
Customer Specified												
Premises Receive												
Level			X	X			X	X	X			
D-Conditioning						X	X		X			
Echo Control												
Improved Return												
Loss			X	X			X					
ELEPL2		X	X	X	X		X					
FlexServ® Service (a.k.a. BellSouth SPA Customer Reconfiguration)	X	X	X	X	X	X	X	X	X	X	X	X
Improved Termination	X	X	X	X	X	X	X	X	X	X	X	X
Simplex Reversal	X	X	X				X	X	X			

Note 1: Effective June 30, 2021, this Service will no longer be available for purchase by new or existing customers. In addition, requests to move, add, change, or renew existing service arrangements will not be accepted. Following the expiration of a customer's existing term agreement, service will be provided on a month-to-month basis at the applicable Monthly rates until the service is discontinued. The Company currently plans to discontinue this service on or after June 30, 2024.

(N)
 |
 (N)

BELLSOUTH
 TELECOMMUNICATIONS
 SOUTH CAROLINA
 ISSUED: June 15, 2021
 BY: President - South Carolina
 Columbia, South Carolina

ACCESS SERVICES TARIFF

Fifth Revised Page 15
 Cancels Fourth Revised Page 15

EFFECTIVE: June 30, 2021

E7. SPECIAL ACCESS (A.K.A. BELLSOUTH SPA) SERVICE

E7.2 Service Descriptions (Cont'd)

E7.2.3 Voice Grade¹ (a.k.a. BellSouth SPA DS0 VG) Service (Cont'd)

(C)

D. Optional Features And Functions (Cont'd)

	Available with Technical Specifications Package VG-											
	1	2	3	4	5	6	7	8	9	10	11	12
Sealing Current Conditioning						X						
Signaling Capability	X	X	X				X	X	X			
Telephoto Conditioning											X	

E. Four-Wire/Two-Wire Conversions

When a customer requests that an effective four-wire channel be terminated with a two-wire channel interface at the customer designated premises, a four-wire to two-wire conversion is required. The rate for the conversion is included as part of the basic Local Channel rate.

F. WATS Access Line¹ (WAL) (a.k.a. BellSouth SPA WATS Line) service

(C)

1. Basic Channel Description

A WATS Access Line (a.k.a. BellSouth SPA WATS Line) service (WAL) provides a channel for voice frequency transmission capability. The service provides a connection between a customer designated premises and a WATS serving office associated with the closed end of *BellSouth SWA 8XX Toll Free Dialing Ten Digit Screening Service*, WATS (a.k.a. BellSouth SPA WATS Line) or similar services. It is provided for use with *BellSouth SWA FGD* in the originating and terminating direction and *BellSouth SWA FGA* and *BellSouth SWA FGB* in the terminating direction and *BellSouth SWA* arrangement features as set forth in Section 6 of Tariff FCC No. 1. The Company is currently unable to provide originating WATS (a.k.a. BellSouth SPA WATS Line) service through *BellSouth SWA FGA* and *BellSouth SWA FGB*. Such service will be provided as specified in 2. and 3. following.

The following shall apply to the Company's provision of WATS Access Line (a.k.a. BellSouth SPA WATS Line) service:

- a. When the end user's serving wire center is not a WATS serving office, channel mileage charges will apply for a WATS access line (a.k.a. BellSouth SPA WATS Line) extension (WALE) between the end user's serving wire center and the nearest WATS serving office.
- b. When a customer, other than AT&T, orders originating WATS Access Line (a.k.a. BellSouth SPA WATS Line) service and the end user's serving wire center is a WATS serving office which is not equipped with equal access, the Company will provide the WAL service to the nearest equal access WATS serving office by use of a WALE and the channel mileage charges for the WALE will be waived.
- c. When a customer other than AT&T orders originating WATS Access Line (a.k.a. BellSouth SPA WATS Line) service and the end user's serving wire center is not a WATS serving office and the nearest WATS serving office is not equipped with equal access, channel mileage charges for a WALE to the nearest WATS serving office will apply, as indicated in 1. preceding, but the Company will provide an additional WALE to the nearest WATS serving office equipped with equal access and the channel mileage charge for the additional WALE will be waived.

Note 1: Effective June 30, 2021, this Service will no longer be available for purchase by new or existing customers. In addition, requests to move, add, change, or renew existing service arrangements will not be accepted. Following the expiration of a customer's existing term agreement, service will be provided on a month-to-month basis at the applicable Monthly rates until the service is discontinued. The Company currently plans to discontinue this service on or after June 30, 2024.

(N)
 |
 (N)

BELLSOUTH
 TELECOMMUNICATIONS
 SOUTH CAROLINA
 ISSUED: June 15, 2021
 BY: President - South Carolina
 Columbia, South Carolina

ACCESS SERVICES TARIFF

Third Revised Page 16
 Cancels Second Revised Page 16

EFFECTIVE: June 30, 2021

E7. SPECIAL ACCESS (A.K.A. BELLSOUTH SPA) SERVICE

E7.2 Service Descriptions (Cont'd)

E7.2.3 Voice Grade¹ (a.k.a. BellSouth SPA DS0 VG) Service (Cont'd)

(C)

F. WATS Access Line¹ (WAL) (a.k.a. BellSouth SPA WATS Line) service (Cont'd)

(C)

1. Basic Channel Description (Cont'd)

c. (Cont'd)

WATS Access Line (a.k.a. BellSouth SPA WATS Line) service is arranged for either originating calling or terminating calling. It is provided with either rotary dial or dual tone multifrequency address signaling and either loop start, ground start, E & M or reverse battery supervisory signaling. The choice of the type of signaling is at the option of the customer and subject to the technical limitations identified in the Technical Reference TR-NPL-000334. WATS Access Line (a.k.a. BellSouth SPA WATS Line) service is provided as an effective two-wire, an effective four-wire or a DS1 (i.e., 1.544 Mbps) transmission path. The DS1 WAL is only available as a trunk side termination on suitably equipped electronic switch, e.g., 1/1A ESS with Digital Carrier Termination (DCT) or DMS-100 with a Line Trunk Unit (LTU).

2. Technical Specification Packages

Parameters	Package WAL -		
	1	2	3
Attenuation Distortion	X	X	
Bit Error Rate			X
C-Message Noise	X	X	
Echo Control	X	X	
Envelope Delay Distortion	X	X	
Frequency Shift	X	X	
Impulse Noise	X	X	
Intermodulation Distortion	X	X	
Loss Deviation	X	X	
Phase Jitter	X	X	
Signal-to-C Notch Noise	X	X	

The technical specifications are delineated in Technical Reference TR-NPL-000334.

3. The following interfaces are available with WAL Service:

LO, LS, DS, GO, GS, RV, EA, EB

Compatible channel interfaces are set forth in Technical Reference TR-NPL-000334.

4. Optional Features and Functions

a. Two-wire and four-wire Central Office bridging capability.

b. Improved two-wire voice transmission specifications.

c. Certain other options associated with WAL services such as WATS Access Line (a.k.a. BellSouth SPA WATS Line) Nonchargeable Termination Options and Common Switching Optional Features are available as defined in Section E6. preceding.

Note 1: Effective June 30, 2021, this Service will no longer be available for purchase by new or existing customers. In addition, requests to move, add, change, or renew existing service arrangements will not be accepted. Following the expiration of a customer's existing term agreement, service will be provided on a month-to-month basis at the applicable Monthly rates until the service is discontinued. The Company currently plans to discontinue this service on or after June 30, 2024.

(N)

(N)

BELLSOUTH
 TELECOMMUNICATIONS
 SOUTH CAROLINA
 ISSUED: June 15, 2021
 BY: President - South Carolina
 Columbia, South Carolina

ACCESS SERVICES TARIFF

Fourth Revised Page 17
 Cancels Third Revised Page 17

EFFECTIVE: June 30, 2021

E7. SPECIAL ACCESS (A.K.A. BELLSOUTH SPA) SERVICE

E7.2 Service Descriptions (Cont'd)

E7.2.3 Voice Grade² (a.k.a. BellSouth SPA DS0 VG) Service (Cont'd)

(C)

F. WATS Access Line² (WAL) (a.k.a. BellSouth SPA WATS Line) service (Cont'd)

(C)

4. Optional Features and Functions (Cont'd)

d. One-way or Two-way Capability

E7.2.4 Wired Music⁽¹⁾ Service

A. Basic Channel Description

A Wired Music⁽¹⁾ channel is a channel specified in bandwidth for the transmission of a complex signal voltage. The actual bandwidth is a function of the channel interface selected by the customer. Only one-way transmission is provided. Wired Music⁽¹⁾ channels are provided between customer designated premises and a Company Hub.

B. Technical Specifications Packages

Parameter	Package AP-			
	1	2	3	4
Actual Measured Loss	X	X	X	X
Amplitude Tracking				
Crosstalk	X	X	X	X
Distortion Tracking				
Gain/Frequency				
Distortion	X	X	X	X
Group Delay				
Noise	X	X	X	X
Phase Tracking				
Short Term Gain				
Stability				
Short-Term Loss				
Total Distortion	X	X	X	X

The technical specifications are delineated in Technical Reference TR-NPL-000337.

C. Channel Interfaces

The following channel interfaces (CIs) define the bandwidths that are available for a Wired Music⁽¹⁾ channel:

CI	Bandwidth
PG-3	Nominal frequency from 200 to 3500 Hz
PG-5	Nominal frequency from 100 to 5000 Hz
PG-8	Nominal frequency from 50 to 8000 Hz

Compatible channel interfaces are set forth in Technical Reference TR-NPL-000337.

Note 1: Effective December 1, 2020, this Service will no longer be available for purchase by new or existing customers, and service agreements may no longer be renewed. In addition, requests to move, add, or change existing service arrangements will not be accepted. Following the expiration of a customer's existing term agreement, service will be provided on a month-to-month basis at the applicable month-to-month rates until the service is discontinued. AT&T currently plans to discontinue this Service on or after December 1, 2021.

Note 2: Effective June 30, 2021, this Service will no longer be available for purchase by new or existing customers. In addition, requests to move, add, change, or renew existing service arrangements will not be accepted. Following the expiration of a customer's existing term agreement, service will be provided on a month-to-month basis at the applicable Monthly rates until the service is discontinued. The Company currently plans to discontinue this service on or after June 30, 2024.

(N)
 |
 (N)

BELLSOUTH
 TELECOMMUNICATIONS
 SOUTH CAROLINA
 ISSUED: June 15, 2021
 BY: President - South Carolina
 Columbia, South Carolina

ACCESS SERVICES TARIFF

Sixth Revised Page 18
 Cancels Fifth Revised Page 18

EFFECTIVE: June 30, 2021

E7. SPECIAL ACCESS (A.K.A. BELLSOUTH SPA) SERVICE

E7.2 Service Descriptions (Cont'd)

E7.2.4 Wired Music² Service (Cont'd)

- D. Optional Features and Functions
 - 1. Central Office Bridging Capability
Distribution Amplifier
 - 2. Gain Conditioning
Control of 1004 Hz AML at initiation of service to 0db + or - 0.5 dB.

Available with Technical Specifications Package AP-

	1	2	3	4
Central Office Bridging Capability				
Gain Conditioning	X	X	X	X

E7.2.5 Digital Data Access³ (a.k.a. BellSouth SPA DS0 Digital Data) Service

(C)

A. Basic Channel Description

A Digital Data (*a.k.a. BellSouth SPA DS0 Digital Data*) channel is a channel for duplex four-wire transmission of synchronous serial data at the rate of 2.4, 4.8, 9.6, 19.2, 56 or 64 Kbps. The actual bit rate is a function of the channel interface selected by the customer. The channel provides a synchronous service with timing provided by the Company through the Company's facilities to the customer in the received bit stream. Digital Data (*a.k.a. BellSouth SPA DS0 Digital Data*) channels are only available via Company designated Digital Data (*a.k.a. BellSouth SPA DS0 Digital Data*) Hubs and are provided between customer designated premises or between a customer designated premises and a Company Digital Data (*a.k.a. BellSouth SPA DS0 Digital Data*) Hub.

A Hub termination charge applies per Digital Local Channel. This rate element covers the Hub functions (e.g., timing, testing) for the service.

Secondary Channel Capability (SCC) is a derived companion digital transmission path that is independent of the primary data path and operates at a substantially lower bit rate. This derived channel allows the customer to perform network management functions during the normal operation of the network. This diagnostics channel utilizes a portion of a customer's previously unavailable data bit stream allowing for the ability to remotely control and test the network and peripheral devices without taking the network out of service. Special customer equipment is necessary to utilize the benefits of the Secondary Channel. Customers not wishing to utilize this capability will not be impacted. Due to transmission equipment restrictions, Secondary Channel cannot be provided on 56 Kbps circuits that require the installation of loop repeater equipment for provision of service. Secondary Channel Capability, also, cannot be provided on 64 Kbps circuits, since all of the available bit stream will be used by the customer.

The customer will provide the Channel Service Unit-type equipment or other Network Channel Terminating Equipment associated with the Digital Data (*a.k.a. BellSouth SPA DS0 Digital Data*) channel at the customer premises. The interim program for interconnection of such equipment is set forth in Technical Reference PUB AS No. 1.

B. Technical Specifications Packages

Parameter	Package DA-					
	1	2	3	4	5	6
Error-Free Seconds ¹	X	X	X	X	X	X

The Company will provide a channel capable of meeting a monthly average performance equal to or greater than 99.875 percent error-free seconds¹ while the channel is in service, if it is measured through a CSU equivalent which is designed, manufactured, and maintained to conform with the specifications contained in Technical Reference PUB 62310.

Note 1: This channel performance does not apply when the Data Over Voice channel option is used.

Note 2: Effective December 1, 2020, this Service will no longer be available for purchase by new or existing customers, and service agreements may no longer be renewed. In addition, requests to move, add, or change existing service arrangements will not be accepted. Following the expiration of a customer's existing term agreement, service will be provided on a month-to-month basis at the applicable month-to-month rates until the service is discontinued. AT&T currently plans to discontinue this Service on or after December 1, 2021

Note 3: Effective June 30, 2021, this Service will no longer be available for purchase by new or existing customers. In addition, requests to move, add, change, or renew existing service arrangements will not be accepted. Following the expiration of a customer's existing term agreement, service will be provided on a month-to-month basis at the applicable Monthly rates until the service is discontinued. The Company currently plans to discontinue this service on or after June 30, 2024.

(N)
 |
 (N)

BELLSOUTH
 TELECOMMUNICATIONS
 SOUTH CAROLINA
 ISSUED: June 15, 2021
 BY: President - South Carolina
 Columbia, South Carolina

ACCESS SERVICES TARIFF

Eighth Revised Page 19
 Cancels Seventh Revised Page 19

EFFECTIVE: June 30, 2021

E7. SPECIAL ACCESS (A.K.A. BELLSOUTH SPA) SERVICE

E7.2 Service Descriptions (Cont'd)

E7.2.5 Digital Data Access² (a.k.a. BellSouth SPA DS0 Digital Data) Service (Cont'd)

(C)

B. Technical Specifications Packages (Cont'd)

Interface options and service objectives for Digital Data Access (a.k.a. BellSouth SPA DS0 Digital Data) service are delineated in Technical Reference TR-NPL-000341.

C. Channel Interfaces

The following channel interfaces (CIs) define the bit rates that are available for a Digital Data (a.k.a. BellSouth SPA DS0 Digital Data) channel:

CI	Bit Rate
DU-24(S) ¹	2.4 Kbps
DU-48(S) ¹	4.8 Kbps
DU-96(S) ¹	9.6 Kbps
DU-19(S) ¹	19.2 Kbps
DU-56(S) ¹	56.0 Kbps
DU-64	64.0 Kbps

Compatible channel interfaces are set forth in Technical Reference TR-NPL-000-341.

D. Optional Features and Functions

1. Central Office Bridging Capability
2. Secondary Channel Capability
3. FlexServ® service (a.k.a. BellSouth SPA Customer Reconfiguration)

FlexServ® service (a.k.a. BellSouth SPA Customer Reconfiguration) provides the customer the ability to monitor and reconfigure Digital Data Access (a.k.a. BellSouth SPA DS0 Digital Data) service provided by the Company. FlexServ® service (a.k.a. BellSouth SPA Customer Reconfiguration) is described in E7.4.12 following. Charges for this feature are contained in E7.5.16 following.

4.

The following table shows the technical specifications packages with which the optional features and functions are available.

- Note 1: (S) is an additional BellSouth designation for use when the optional Secondary Channel feature is required.
- Note 2: Effective June 30, 2021, this Service will no longer be available for purchase by new or existing customers. In addition, requests to move, add, change, or renew existing service arrangements will not be accepted. Following the expiration of a customer's existing term agreement, service will be provided on a month-to-month basis at the applicable Monthly rates until the service is discontinued. The Company currently plans to discontinue this service on or after June 30, 2024.

(N)
 |
 (N)

BELLSOUTH
 TELECOMMUNICATIONS
 SOUTH CAROLINA
 ISSUED: June 15, 2021
 BY: President - South Carolina
 Columbia, South Carolina

ACCESS SERVICES TARIFF

Third Revised Page 19.0.1
 Cancels Second Revised Page 19.0.1

EFFECTIVE: June 30, 2021

E7. SPECIAL ACCESS (A.K.A. BELLSOUTH SPA) SERVICE

E7.2 Service Descriptions (Cont'd)

E7.2.5 Digital Data Access¹ (a.k.a. BellSouth SPA DS0 Digital Data) Service (Cont'd)

(C)

D. Optional Features and Functions (Cont'd)

4. Data Over Voice Channel (Cont'd)

	Available with Technical Specifications Package DA-					
	1	2	3	4	5	6
Central Office Bridging						
Capability	X	X	X	X	X	
Secondary Channel Capability	X	X	X	X	X	
FlexServ [®] Service (a.k.a. BellSouth SPA Customer Reconfiguration)	X	X	X	X	X	X

Note 1: Effective June 30, 2021, this Service will no longer be available for purchase by new or existing customers. In addition, requests to move, add, change, or renew existing service arrangements will not be accepted. Following the expiration of a customer's existing term agreement, service will be provided on a month-to-month basis at the applicable Monthly rates until the service is discontinued. The Company currently plans to discontinue this service on or after June 30, 2024.

(N)
 |
 (N)

BELLSOUTH
 TELECOMMUNICATIONS
 SOUTH CAROLINA
 ISSUED: June 15, 2021
 BY: President - South Carolina
 Columbia, South Carolina

ACCESS SERVICES TARIFF

Third Revised Page 19.1
 Cancels Second Revised Page 19.1

EFFECTIVE: June 30, 2021

E7. SPECIAL ACCESS (A.K.A. BELLSOUTH SPA) SERVICE

E7.2 Service Descriptions (Cont'd)

E7.2.6 High Capacity (a.k.a. BellSouth SPA High Capacity) Service

A. Basic Channel Description

A High Capacity (*a.k.a. BellSouth SPA High Capacity*) channel is a channel for the transmission of nominal 64.0 Kbps^{1, 2} or 1.544, 3.152, 6.312, or 44.736 Mbps isochronous serial data. The actual bit rate is a function of the channel interface selected by the customer. High Capacity (*a.k.a. BellSouth SPA High Capacity*) channels are provided between customer designated premises or between a customer designated premises and a Company Hub. (C)

The customer will provide the Network Channel Terminating Equipment associated with the High Capacity (*a.k.a. BellSouth SPA High Capacity*) channel at the customer's premises. The interim program for interconnection of such equipment is set forth in Technical Reference PUB AS No. 1.

B. Technical Specifications Packages

Parameters	Package HC-					
	0	1	1C	2	3	4
Error-Free Seconds			X			

Note 1: Available only as a cross connect (through connection) of two 2.4, 4.8, 9.6, 19.2, 56.0 or 64.0 Kbps channels of two 1.544 Mbps facilities to a Digital Data (*a.k.a. BellSouth SPA DS0 Digital Data*) Hub(s). The customer must provide system and channel assignment data.

Note 2: Effective June 30, 2021, this Service will no longer be available for purchase by new or existing customers. In addition, requests to move, add, change, or renew existing service arrangements will not be accepted. Following the expiration of a customer's existing term agreement, service will be provided on a month-to-month basis at the applicable Monthly rates until the service is discontinued. The Company currently plans to discontinue this service on or after June 30, 2024.

(N)
 |
 (N)

BELLSOUTH
TELECOMMUNICATIONS
SOUTH CAROLINA
ISSUED: June 15, 2021
BY: President - South Carolina
Columbia, South Carolina

ACCESS SERVICES TARIFF

Seventh Revised Page 20
Cancels Sixth Revised Page 20

EFFECTIVE: June 30, 2021

E7. SPECIAL ACCESS (A.K.A. BELLSOUTH SPA) SERVICE**E7.2 Service Descriptions (Cont'd)****E7.2.6 High Capacity (a.k.a. BellSouth SPA High Capacity) Service (Cont'd)**

B. Technical Specifications Packages (Cont'd)

A channel with technical specifications package HC1 will be capable of an error-free second performance of 98.75 percent over a continuous twenty-four hour period as measured at the 1.544 Mbps rate through a CSU equivalent which is designed, manufactured, and maintained to conform with the specifications contained in Technical Reference TR-NPL-000054.

C. Channel Interfaces

The following channel interfaces (CIs) define the bit rates that are available for a High Capacity (*a.k.a. BellSouth SPA High Capacity*) channel:

CI	Bit Rate
DS-15 ^{1,2}	1.544 Mbps (DS1)
DS-31	3.152 Mbps (DS1C)
DS-44	44.736 Mbps (DS3)
DS-63	6.312 Mbps (DS2)

(C)

Compatible channel interfaces are set forth in Technical Reference TA-TSY-000342.

D. Optional Features and Functions

1.

2. Channelization

a. DS3 to DS1

An arrangement that channelizes a 44.736 Mbps channel to 28 DS1 channels.

b. DS2 to DS1

An arrangement that channelizes a 6.312 Mbps channel to four DS1 channels.

c. DS1C to DS1

An arrangement that channelizes a 3.152 Mbps channel to two DS1 channels.

Note 1: A 64.0 Kbps channel is available as a channel(s) of a 1.544 Mbps facility to a Company hub.

Note 2: Effective June 30, 2021, 64.0 Kbps will no longer be available for purchase by new or existing customers. In addition, requests to move, add, change, or renew existing service arrangements will not be accepted. Following the expiration of a customer's existing term agreement, service will be provided on a month-to-month basis at the applicable Monthly rates until the service is discontinued. The Company currently plans to discontinue this service on or after June 30, 2024.

(N)

(N)

BELLSOUTH
TELECOMMUNICATIONS
SOUTH CAROLINA
ISSUED: June 15, 2021
BY: President - South Carolina
Columbia, South Carolina

ACCESS SERVICES TARIFF

Ninth Revised Page 21
Cancels Eighth Revised Page 21

EFFECTIVE: June 30, 2021

E7. SPECIAL ACCESS (A.K.A. BELLSOUTH SPA) SERVICE

E7.2 Service Descriptions (Cont'd)

E7.2.6 High Capacity (*a.k.a. BellSouth SPA High Capacity*) Service (Cont'd)

D. Optional Features and Functions (Cont'd)

2. Channelization (Cont'd)

e. DS1 Basic Channelization System

An arrangement that channelizes a 1.544 Mbps channel to a maximum of twenty-four 64.0 Kbps channels that may be used to activate both analog and digital services, e.g., voice grade, program audio, and digital data access service. A Basic Channelization System requires a Central Office Channel Interface for each channel of lesser capacity.

f. DS0 Basic Channelization System¹

An arrangement that channelizes a 64.0 Kbps channel to subspeeds of up to twenty 2.4 Kbps, ten 4.8 Kbps, or five 9.6 Kbps channels. A Basic Channelization System requires a Central Office Channel Interface for each channel of lesser capacity.

3. Channel Interface

a. DS1 Level Central Office Channel Interface

An arrangement for the connection of DS1 (1.544 Mbps) channels to higher order DS3 (44.736 Mbps) services, in Company central office locations.

b. DS1 Level Customer Channel Interface

An arrangement for the connection of DS1 (1.544 Mbps) channels to higher order DS3 (44.736 Mbps) services, at customer locations.

c. DS0 Level Central Office Channel Interface¹

An arrangement for the connection of VG/DS0 (2.4-64.0 Kbps) channels to higher order DS1 (1.544 Mbps) services, in Company central office locations.

d. Subrate Level Central Office Channel Interface¹

An arrangement for the connection of subrate (2.4-9.6 Kbps) channels to higher order DS0 (64.0 Kbps) services, in Company central office locations.

4. Clear Channel Capability

a. Clear Channel Capability (CCC) is an arrangement that alters a DS1/1.544 Mbps signal with unconstrained information bits, to meet pulse density requirements outlined in TR-NPL-000054 and TA-TSY-000342. This will allow a customer to transport an all zero octet over a DS1/1.544 Mbps High Capacity (*a.k.a. BellSouth SPA DS1*) channel, providing an available combined maximum 1.536 Mbps data rate. This arrangement requires the customer signal at the channel interface to conform to Bipolar with 8 Zero Substitution (B8ZS) line code as described in TR-NPL-000054 and TA-TSY-000342.

b. CCC is provided on DS1/1.544 Mbps High Capacity (*a.k.a. BellSouth SPA DS1*) channels between two customer designated premises, or between a customer designated premises and a Company Hub location, and is subject to the availability of facilities. This optional feature may be ordered at the same time the DS1/1.544 Mbps High Capacity (*a.k.a. BellSouth SPA DS1*) channel is ordered, or it may be ordered as an additional feature of an existing channel.

c. When providing CCC via a DS3/44.736 Mbps High Capacity (*a.k.a. BellSouth SPA DS3*) channel, that DS3 channel must be designated, in Company records, as having Clear Channel Capability prior to the provisioning of a DS1/1.544 Mbps High Capacity (*a.k.a. BellSouth SPA DS1*) channel with CCC. Customers must agree to out-of-service periods required to add this feature to; 1) an existing DS1/1.544 Mbps High Capacity (*a.k.a. BellSouth SPA DS1*) channel or 2) a DS3/44.736 Mbps High Capacity (*a.k.a. BellSouth SPA DS3*) channel which transports a DS1/1.544 Mbps High Capacity (*a.k.a. BellSouth SPA DS1*) channel, to be optioned for B8ZS.

5. FlexServ® service (*a.k.a. BellSouth SPA Customer Reconfiguration*)

FlexServ® service (*a.k.a. BellSouth SPA Customer Reconfiguration*) provides the customer the ability to monitor and reconfigure High Capacity (*a.k.a. BellSouth SPA High Capacity*) service provided by the Company. FlexServ® service (*a.k.a. BellSouth SPA Customer Reconfiguration*) is described in E7.4.12 following. Charges for this feature are contained in E7.5.16 following.

Note 1: Effective June 30, 2021, this Service will no longer be available for purchase by new or existing customers. In addition, requests to move, add, change, or renew existing service arrangements will not be accepted. Following the expiration of a customer's existing term agreement, service will be provided on a month-to-month basis at the applicable Monthly rates until the service is discontinued. The Company currently plans to discontinue this service on or after June 30, 2024.

(C)

(C)

(C)

(N)

(N)

BELLSOUTH
 TELECOMMUNICATIONS
 SOUTH CAROLINA
 ISSUED: June 15, 2021
 BY: President - South Carolina
 Columbia, South Carolina

ACCESS SERVICES TARIFF

Eleventh Revised Page 21.1
 Cancels Tenth Revised Page 21.1

EFFECTIVE: June 30, 2021

E7. SPECIAL ACCESS (A.K.A. BELLSOUTH SPA) SERVICE

E7.2 Service Descriptions (Cont'd)

E7.2.6 High Capacity (a.k.a. BellSouth SPA High Capacity) Service (Cont'd)

D. Optional Features and Functions (Cont'd)

The following table shows the technical specifications packages with which the optional features and functions are available.

	Available With Technical Specifications Package HC-			
	0	1	1C	2 3
Channelization				
DS3 to DS1				X
DS2 to DS1				X
DS1C to DS1			X	
DS1 Basic Channelization System		X		
DS0 Basic Channelization System ^{1,2}		X		
Clear Channel Capability				X
FlexServ [®] Service (a.k.a. BellSouth SPA Customer Reconfiguration)	X	X		

(C)

E7.2.7 Reserved for Future Use

E7.2.8 Reserved for Future Use

E7.2.9 Reserved for Future Use

E7.2.10 Reserved for Future Use

E7.2.11 Reserved for Future Use

E7.2.12 Reserved for Future Use

E7.2.13 Reserved for Future Use

E7.2.14 (DELETED)

Note 1: Available only on 64.0 Kbps DDAS (a.k.a. BellSouth SPA DS0 Digital Data) service or on a DS1 (1.544 Mbps) channel with Clear Channel Capability to a Company hub.

Note 2: Effective June 30, 2021, this Service will no longer be available for purchase by new or existing customers. In addition, requests to move, add, change, or renew existing service arrangements will not be accepted. Following the expiration of a customer's existing term agreement, service will be provided on a month-to-month basis at the applicable Monthly rates until the service is discontinued. The Company currently plans to discontinue this service on or after June 30, 2024.

(N)

(N)

BELLSOUTH
TELECOMMUNICATIONS
SOUTH CAROLINA
ISSUED: June 15, 2021
BY: President - South Carolina
Columbia, South Carolina

ACCESS SERVICES TARIFF

Seventh Revised Page 21.3
Cancels Sixth Revised Page 21.3

EFFECTIVE: June 30, 2021

E7. SPECIAL ACCESS (A.K.A. BELLSOUTH SPA) SERVICE**E7.2 Service Descriptions (Cont'd)****E7.2.14 (DELETED) (Cont'd)****E7.2.15 Derived Data Channel¹ (a.k.a. BellSouth SPA Derived Data Channel) Service**

(C)

A. Basic Service Description

Derived Data Channel (a.k.a. BellSouth SPA Derived Data Channel) service (DDCS) provides full-duplex asynchronous or synchronous data transmission utilizing data over voice and subrate multiplexing technology. DDCS (a.k.a. BellSouth SPA Derived Data Channel) provides simultaneous data and voice transmissions over the customer's existing two-wire local exchange facility. A derived data channel is provided between the customer's premises and the customer's serving wire center.

At the customer's serving wire center the data/voice terminating equipment provides subrate multiplexing into a standard DS0-B interface for a group composed of a maximum of twenty derived data channels. The customer's derived data channel must be associated with a DS0-B interface. This association requires coordination between the subscriber of the derived data channel and the subscriber of the DS0-B interface. An interoffice channel is provided for interconnection of the subrate multiplexed DS0-B interface to the serving wire center of a customer designated premises.

DDCS (a.k.a. BellSouth SPA Derived Data Channel) is provided subject to the availability of appropriate network facilities and equipment and subject to the transmission limitations of the facilities and equipment used by the Company.

The customer will be responsible for selecting his own Customer Premises Equipment (CPE). CPE must be compatible with the Company provided terminating equipment at the serving wire center.

B. Channel Interfaces

The following channel interface (CI) is available for DDCS (a.k.a. BellSouth SPA Derived Data Channel) .

CI	Bit Rate
2DV5.BA	2.4 Kbps, Digital Data Over Voice ¹

(C)

Compatible channel interface specifications are contained in BellSouth Technical Reference Publication 73548 for data/voice multiplexing equipment and BellSouth Technical Reference 73548, Addendum 1, for the DS0-B interface. These publications are available from the Information Exchange Manager, BellSouth Telecommunications, Inc., Documentations Operations, North W5A1, 3535 Colonnade Parkway, Birmingham, Alabama 35243.

Note 1: Effective June 30, 2021, this Service will no longer be available for purchase by new or existing customers. In addition, requests to move, add, change, or renew existing service arrangements will not be accepted. Following the expiration of a customer's existing term agreement, service will be provided on a month-to-month basis at the applicable Monthly rates until the service is discontinued. The Company currently plans to discontinue this service on or after June 30, 2024.

(N)

(N)

BELLSOUTH
 TELECOMMUNICATIONS
 SOUTH CAROLINA
 ISSUED: June 15, 2021
 BY: President - South Carolina
 Columbia, South Carolina

ACCESS SERVICES TARIFF

Ninth Revised Page 22
 Cancels Eighth Revised Page 22

EFFECTIVE: June 30, 2021

E7. SPECIAL ACCESS (A.K.A. BELLSOUTH SPA) SERVICE

E7.3 Channel Interface and Network Channel Codes

E7.3.1 General

A. This subsection explains the Channel Interface codes and Network Channel codes that the customer must specify when ordering Special Access (a.k.a. BellSouth SPA) service. Included is an example which explains the specific characters of the code, a glossary of Channel Interface codes, impedance levels, Network Channel codes and compatible Channel Interfaces.

Example: If the customer specifies a LB Network Channel Code and a 2LC8 Channel Interface at the customer's premises, the following is being requested:

1. LB = Voice Grade¹ Channel with a Predefined Technical Specification Package (1) (C)
2. 2 = Number of physical wires at customer premises
3. LC = Facility interface for Type C Signaling.
4. 8 = Variable impedance level

E7.3.2 Glossary of Channel Interface Codes and Options

Code - Option	Definition	
AB -	Accepts 20 Hz ringing signal at customer's point of termination	
AC -	Accepts 20 Hz ringing signal at the customer's end user's point of termination	
CS -	Digital hierarchy interface at Digital Crossconnect System (DCS)	
- EA	E&M Signaling	
- GO	Ground Start Loop Signaling - Open End	
- GS	Ground Start Loop Signaling - Closed End	
- LO	Loop Start Loop Signaling - Open End	
- LS	Loop Start Loop Signaling - Closed End	
- NO	Transmission Only - No Signaling	
- R	(DS0) Customer Reconfiguration Voice Grade Service ¹	(C)
- 10R	DS1 to DS0 ¹ Customer Reconfigurable	
- 10	DS1 to DS0 ¹	(C)
- 11R	DS1 to DS1 Customer Reconfigurable	
- 11	DS1 to DS1	
- SP	Resistive Type: Split Path Operation for Data Polling Conference Type	
- CF	Resistive Type: Split Path Operation for Symmetrical Voice Conference Type	
- BC	CO Bridging: Broadcast for Broadcast Conference Type	

Note 1: Effective June 30, 2021, this Service will no longer be available for purchase by new or existing customers. In addition, requests to move, add, change, or renew existing service arrangements will not be accepted. Following the expiration of a customer's existing term agreement, service will be provided on a month-to-month basis at the applicable Monthly rates until the service is discontinued. The Company currently plans to discontinue this service on or after June 30, 2024. (N)

BELLSOUTH
TELECOMMUNICATIONS
SOUTH CAROLINA
ISSUED: June 15, 2021
BY: President - South Carolina
Columbia, South Carolina

ACCESS SERVICES TARIFF

Third Revised Page 22.1
Cancels Second Revised Page 22.1

EFFECTIVE: June 30, 2021

E7. SPECIAL ACCESS (A.K.A. BELLSOUTH SPA) SERVICE**E7.3 Channel Interface and Network Channel Codes (Cont'd)****E7.3.2 Glossary of Channel Interface Codes and Options (Cont'd)**

Code - Option	Definition	
CT -	Centrex Type Services Tie Trunk Termination	
DA -	Data stream in VF frequency band at customer's end user's point of termination	
DB -	Data stream in VF frequency band at customer's point of termination	
- 10	VF for TG1 and TG2	
- 43	VF for 43 Telegraph ¹ Carrier type signals, TG1 and TG2	(C)
DS -	Digital hierarchy interface	
- 1K	1.544 Mbps (DS1) ANSI Extended Superframe (ESF) format per TA-TSY-000342	
- 1S	1.544 Mbps (DS1) ANSI Extended Superframe (ESF) format and B8ZS Clear Channel Capability per TA-TSY-000342	
- 15	1.544 Mbps (DS1) Superframe (SF) format per TA-TSY-000342	

Note 1: Effective June 30, 2021, this Service will no longer be available for purchase by new or existing customers. In addition, requests to move, add, change, or renew existing service arrangements will not be accepted. Following the expiration of a customer's existing term agreement, service will be provided on a month-to-month basis at the applicable Monthly rates until the service is discontinued. The Company currently plans to discontinue this service on or after June 30, 2024.

(N)
|
(N)

BELLSOUTH
 TELECOMMUNICATIONS
 SOUTH CAROLINA
 ISSUED: June 15, 2021
 BY: President - South Carolina
 Columbia, South Carolina

ACCESS SERVICES TARIFF

Sixth Revised Page 23
 Cancels Fifth Revised Page 23

EFFECTIVE: June 30, 2021

E7. SPECIAL ACCESS (A.K.A. BELLSOUTH SPA) SERVICE

E7.3 Channel Interface and Network Channel Codes (Cont'd)

E7.3.2 Glossary of Channel Interface Codes and Options (Cont'd)

Code - Option	Definition
- 15B	1.544 Mbps (DS1) Superframe (SF) format and B8ZS Clear Channel Capability per TA-TSY-000342
- 15E	8-bit PCM encoded in one 64 Kbps of the DS1 signal
- 15F	8-bit PCM encoded in two 64 Kbps of the DS1 signal
- 15G	8-bit PCM encoded in three 64 Kbps of the DS1 signal
- 15H	14/11-bit PCM encoded in six 64 Kbps of the DS1 signal
- 15J	1.544 Mbps format per PUB 41451 (only available to U. S. Govt. agencies)
- 31	3.152 Mbps (DS1C)
- 31L	3.152 Mbps (DS1C) with SF signaling
- 44	44.736 Mbps (DS3)
- 44L	44.736 Mbps (DS3) with SF signaling
- 63	6.312 Mbps (DS2)
- 63L	6.312 Mbps (DS2) with SF signaling
DU	Digital access interface
- 19 (S) ¹	19.2 Kbps ²
- 24 (S) ¹	2.4 Kbps ²
- 48 (S) ¹	4.8 Kbps ²
- 56 (S) ¹	56.0 Kbps ²
- 64	64.0 Kbps ²
- 96 (S) ¹	9.6 Kbps ²
- 1KN	DS1 (1.544 Mbps) ANSI Extended Superframe (ESF) Format per TR-NPL-000054 without line power
- 1SN	DS1 (1.544 Mbps) ANSI Extended Superframe (ESF) Format per TR-NPL-000054, with B8ZS Clear Channel Capability and without line power
- A	DS1 1.544 Mbps free-framing format per PUB 41451 with line power (only available to U. S. Govt. agencies)
- AN	DS1 (1.544 Mbps) free-framing format per PUB 41451 without line power (only available to U. S. Govt. agencies)
- BN	DS1 (1.544 Mbps) Superframe (SF) Format per TR-NPL-000054 without line power

Note 1: (S) is an additional BellSouth designation for use when the optional Secondary Channel feature is required.

Note 2: Effective June 30, 2021, this Service will no longer be available for purchase by new or existing customers. In addition, requests to move, add, change, or renew existing service arrangements will not be accepted. Following the expiration of a customer's existing term agreement, service will be provided on a month-to-month basis at the applicable Monthly rates until the service is discontinued. The Company currently plans to discontinue this service on or after June 30, 2024.

(C)
 |
 (C)

(N)
 |
 (N)

BELLSOUTH
TELECOMMUNICATIONS
SOUTH CAROLINA
ISSUED: June 15, 2021
BY: President - South Carolina
Columbia, South Carolina

ACCESS SERVICES TARIFF

Fourth Revised Page 23.1
Cancels Third Revised Page 23.1

EFFECTIVE: June 30, 2021

E7. SPECIAL ACCESS (A.K.A. BELLSOUTH SPA) SERVICE**E7.3 Channel Interface and Network Channel Codes (Cont'd)****E7.3.2 Glossary of Channel Interface Codes and Options (Cont'd)**

Code - Option	Definition
- DN	DS1 (1.544 Mbps) Superframe (SF) Format per TR-NPL-000054, with B8ZS Clear Channel Capability and without line power.
- SN	1.544 Mbps (DS1) "ANSI" Extended Superframe (ESF) format and B8ZS Clear Channel Capability
DV -	Data and Voice Multiplexing
- BC	Digital Data Over Voice, 9.6 Kbps ¹ (C)
DX -	Duplex signaling interface at customer's point of termination
DY -	Duplex signaling interface at customer's end user's point of termination.
EA - E	Type I E&M Lead Signaling. Customer at POT or customer's end user at POT originates on E Lead.
EA - M	Type I E&M Lead Signaling. Customer at POT or customer's end user at POT originates on M Lead.

Note 1: Effective June 30, 2021, this Service will no longer be available for purchase by new or existing customers. In addition, requests to move, add, change, or renew existing service arrangements will not be accepted. Following the expiration of a customer's existing term agreement, service will be provided on a month-to-month basis at the applicable Monthly rates until the service is discontinued. The Company currently plans to discontinue this service on or after June 30, 2024.

(N)
|
(N)

BELLSOUTH
 TELECOMMUNICATIONS
 SOUTH CAROLINA
 ISSUED: June 15, 2021
 BY: President - South Carolina
 Columbia, South Carolina

ACCESS SERVICES TARIFF

Sixth Revised Page 25
 Cancels Fifth Revised Page 25

EFFECTIVE: June 30, 2021

E7. SPECIAL ACCESS (A.K.A. BELLSOUTH SPA) SERVICE

E7.3 Channel Interface and Network Channel Codes (Cont'd)

E7.3.2 Glossary of Channel Interface Codes and Options (Cont'd)

Code - Option	Definition	
- 8	Nominal frequency from 50 to 8,000 Hz	
PR -	Protective relaying ¹	
RV - 0	Reverse battery signaling, one way operation, originate by customer	
- T	Reverse battery signaling, one way operation, terminate function by customer or customer's end user	
SF -	Single frequency signaling with VF band at either customer POT or customer's end user POT	
TF -	Telephotograph ² interface	(C)
TT -	Telegraph ² /teletypewriter interface at either customer POT or customer's end user POT	(C)
- 2	20.0 milliamperes	
TT - 3	3.0 milliamperes	
- 6	62.5 milliamperes	
(DELETED)		

E7.3.3 Impedance

The nominal reference impedance with which the channel will be terminated for the purpose of evaluating transmission performance:

Value (ohms)	Code(s)
110	0
150	1
600	2
900	3
135	5
75	6
124	7
Variable	8
100	9

Note 1: Available only for the transmission of audio tone protective relaying signals used in the protection of electric power systems during fault conditions.

Note 2: Effective June 30, 2021, this Service will no longer be available for purchase by new or existing customers. In addition, requests to move, add, change, or renew existing service arrangements will not be accepted. Following the expiration of a customer's existing term agreement, service will be provided on a month-to-month basis at the applicable Monthly rates until the service is discontinued. The Company currently plans to discontinue this service on or after June 30, 2024.

(N)
 |
 (N)

BELLSOUTH
 TELECOMMUNICATIONS
 SOUTH CAROLINA
 ISSUED: June 15, 2021
 BY: President - South Carolina
 Columbia, South Carolina

ACCESS SERVICES TARIFF

Sixteenth Revised Page 27
 Cancels Fifteenth Revised Page 27

EFFECTIVE: June 30, 2021

E7. SPECIAL ACCESS (A.K.A. BELLSOUTH SPA) SERVICE

E7.3 Channel Interface and Network Channel Codes (Cont'd)

E7.3.5 Service Designator/Network Channel Code Conversion Table (Cont'd)

Service Designator	Network Channel
Code	Code
AP1	PE
AP2	PF
AP3	PJ
AP4	PK
TV3	TZ
DA1	XA
DA2	XB
DA3	XG
DA4	XH
DA5	XE
DA6	YN
HC0	HS
HC1	HC
HC1C	HD
HC2	HE
HC3	HF

E7.4 Rate Regulations

This subsection contains the specific regulations governing the rates and charges that apply for Special Access (a.k.a. BellSouth SPA) service.

E7.4.1 Types of Rates and Charges

A. There are two types of rates and charges. These are monthly rates and nonrecurring charges. The rates and charges are described as follows:

1. Monthly Rates

Monthly rates are flat recurring rates that apply each or fraction thereof that a Special Access (a.k.a. BellSouth SPA) service is provided. For billing purposes, each month is considered to have thirty days.

Digital Data Access² (a.k.a. BellSouth SPA DS0 Digital Data) service is offered under the contract plans as described in E7.4.14 following. Derived Data Channel² (a.k.a. BellSouth SPA Derived Data Channel) service is offered under two contract plans. Contract plan rates are available in payment periods from twenty-four to forty-two months¹ and in payment periods from forty-three to sixty months¹ under conditions specified in the Channel Services Payment Plan in E2.4 of this Tariff. These payment periods are an exception to those listed in E2.4 of this Tariff. Termination Liability Charges will not apply for IC or end user requests for moves of service under CSPP subject to the provisions set forth in E2.4.9.A.8. preceding. A Termination Liability Charge is applicable at the date of termination if the customer terminates or disconnects the service prior to fulfilling the period of the contract plan, except as specified in b. following. The Termination Liability Charge is determined by multiplying the contracted monthly rate times the number of months in the contract plan, less the contracted monthly rate times the number of months the service has been installed, **multiplied by a factor. The factor is fifty percent (50%) for contracts that have been in effect twelve months or less, or twenty percent (20%) for contracts that have been in effect longer than twelve months.** An example is provided in a. following. (C)

Note 1: Effective May 1, 2019, Customers may not convert, renew or establish CSPPs for Digital Data Access and Derived Data Channel Service.

Note 2: Effective June 30, 2021, this Service will no longer be available for purchase by new or existing customers. In addition, requests to move, add, change, or renew existing service arrangements will not be accepted. Following the expiration of a customer's existing term agreement, service will be provided on a month-to-month basis at the applicable Monthly rates until the service is discontinued. The Company currently plans to discontinue this service on or after June 30, 2024.

(N)
 |
 (N)

BELLSOUTH
TELECOMMUNICATIONS
SOUTH CAROLINA
ISSUED: June 15, 2021
BY: President - South Carolina
Columbia, South Carolina

ACCESS SERVICES TARIFF

Eleventh Revised Page 27.1
Cancels Tenth Revised Page 27.1

EFFECTIVE: June 30, 2021

E7. SPECIAL ACCESS (A.K.A. BELLSOUTH SPA) SERVICE**E7.4 Rate Regulations (Cont'd)****E7.4.1 Types of Rates and Charges (Cont'd)**

A. (Cont'd)

1. Monthly Rates (Cont'd)

- a. An end user or IC subscribes to Derived Data Channel² (a.k.a. BellSouth SPA Derived Data Channel) service using the twenty-four to forty-two month¹ payment plan. The contract plan period is for thirty months. The subscriber terminates the service after twelve months. The total liability charge is thirty months times the monthly rate. The amount is then reduced to reflect the number of months the subscriber has had the service, which in this example is twelve months. Therefore, the Termination Liability Charge is *fifty percent (50%) of this amount* calculated as follows: (C)
- $$\text{Termination Liability Charge} = .50 \times [(30 \text{ months} \times \text{monthly rate}) - (12 \text{ months} \times \text{monthly rate})]$$
- b. A Termination Liability Charge will not be applicable at the date of termination if the customer terminates or disconnects the service prior to fulfilling the period of the contract plan for customer requested changes to a higher order of service covered by the Channel Services Payment Plan¹ as specified in E2.4.9.A.4.b., or IC or end user requested changes to services not covered by the Channel Services Payment Plan¹ that are offered by the Company under a contract payment plan provided that the applicable conditions set forth in E2.4.9.A.4.b. are satisfied.

Contract rates are available for 1.544 Mbps High Capacity (a.k.a. BellSouth SPA DS1) service for variable periods, with rates based on lengths of thirty-six months, sixty months, or eighty-four months¹ under conditions specified in the Channel Service Payment Plan in E2.4 of this Tariff. A Termination Liability Charge is applicable at the date of termination. The applicable charge will be equal to the number of months remaining in the contract times the monthly contract rate. However, Termination Liability Charges will not apply for IC or end user requests for moves of service under CSPP subject to the provisions set forth in E2.4.9.A.8. preceding.

Note 1: Effective May 1, 2019, Customers may not: (1) Establish, convert or renew CSPPs for Derived Data Channel Service, (2) Establish CSPPs greater than 36 months for High Capacity Service, and (3) Convert or renew CSPPs for High Capacity Service.

Note 2: Effective June 30, 2021, this Service will no longer be available for purchase by new or existing customers. In addition, requests to move, add, change, or renew existing service arrangements will not be accepted. Following the expiration of a customer's existing term agreement, service will be provided on a month-to-month basis at the applicable Monthly rates until the service is discontinued. The Company currently plans to discontinue this service on or after June 30, 2024.

(N)
|
(N)

BELLSOUTH
TELECOMMUNICATIONS
SOUTH CAROLINA
ISSUED: June 15, 2021
BY: President - South Carolina
Columbia, South Carolina

ACCESS SERVICES TARIFF

Fifteenth Revised Page 28
Cancels Fourteenth Revised Page 28

EFFECTIVE: June 30, 2021

E7. SPECIAL ACCESS (A.K.A. BELLSOUTH SPA) SERVICE**E7.4 Rate Regulations (Cont'd)****E7.4.1 Types of Rates and Charges (Cont'd)**

A. (Cont'd)

2. Nonrecurring Charges

Nonrecurring charges are one-time charges that apply for specific work activity (i.e., installation or change to an existing service). The types of nonrecurring charges that apply for Special Access (a.k.a. BellSouth SPA) service are:

- Installation of service,
- Installation of optional features and functions, and
- Service rearrangements

The following list identifies the individual Special Access (a.k.a. BellSouth SPA) services provided under Section E7. of this Tariff which are eligible for credit of nonrecurring charges under "Service Installation Guarantee" found in E2.4.10 *of this Tariff*. Customers with these services are not eligible for the Service Installation Guarantee when the requested installation, move or rearrangement service order interval is four days or less as measured from the Application Date of the order.

- Voice Grade⁽³⁾ (a.k.a. BellSouth SPA DS0 VG), (C)
- Wired Music⁽²⁾, (C)
- Digital Data Access (a.k.a. BellSouth SPA DS0 Digital Data) service⁽¹⁾⁽³⁾, (C)
- High Capacity (a.k.a. BellSouth SPA High Capacity) service
- SMARTRing service (a.k.a. BellSouth Dedicated Ring)

Provided, however, that the following services are not eligible for such credit.

- FlexServ service (a.k.a. BellSouth SPA Customer Reconfiguration)
- Derived Data Channel⁽³⁾ (a.k.a. BellSouth SPA Derived Data Channel) service (C)
- BellSouth Metro Ethernet service

a. Installation of Service

Nonrecurring charges apply to each service installed. When one service is ordered and installed, it is billed at the First Service Installed rate. When more than one of the same type of service, between the same locations, for the same customer is ordered and installed at the same time, one at each location is billed at the First Service Installed rate and the others are billed at the Additional Service Installed rate. Nonrecurring charges are per each rate element for Commercial Quality Video (a.k.a. BellSouth SPA Commercial Quality Video) service.

b. Installation of Optional Features and Functions

Nonrecurring charges apply for the installation of some of the optional features and functions available with Special Access (a.k.a. BellSouth SPA) service. The Initial nonrecurring charge applies if the feature or function is installed coincident with the primary service. The Subsequent nonrecurring charge applies if the feature or function is installed after the installation of the primary service.

First and Additional nonrecurring charges are applicable to activate each individual Central Office Channel Interface of a DS1 or DS0 Basic Channelization System⁽³⁾ and are in addition to the nonrecurring charges for the DS1 or DS0 Basic Channelization System⁽³⁾. A "First" Central Office Channel Interface nonrecurring charge is applicable to the first Central Office Channel Interface installed coincident with the installation of a DS1 or DS0 Basic Channelization System⁽³⁾, per service request. The "Additional" nonrecurring charge applies for each additional Central Office Channel Interface, of the same type, ordered and installed at the same location, for the same customer, at the same time, on the same order request. Future requests for a Central Office Channel Interface on an existing DS1 or DS0 Basic Channelization System⁽³⁾ will be treated as new requests and will require "First" and "Additional" Central Office Channel Interface nonrecurring charge application in addition to any other applicable charges. (C)

One nonrecurring charge is applicable for each individual DS1 level central office or customer channel interface, and is in addition to any other applicable charge(s).

The nonrecurring charges for the installation of optional features and functions are set forth in E7.5 following as nonrecurring charges for optional features and functions associated with the specific services.

Note 1: The Data Over Voice Channel optional feature is not eligible for such credit.

Note 2: Effective December 1, 2020, this Service will no longer be available for purchase by new or existing customers, and service agreements may no longer be renewed. In addition, requests to move, add, or change existing service arrangements will not be accepted. Following the expiration of a customer's existing term agreement, service will be provided on a month-to-month basis at the applicable month-to-month rates until the service is discontinued. AT&T currently plans to discontinue this Service on or after December 1, 2021.

Note 3: Effective June 30, 2021, this Service will no longer be available for purchase by new or existing customers. In addition, requests to move, add, change, or renew existing service arrangements will not be accepted. Following the expiration of a customer's existing term agreement, service will be provided on a month-to-month basis at the applicable Monthly rates until the service is discontinued. The Company currently plans to discontinue this service on or after June 30, 2024.

(N)
|
(N)

BELLSOUTH
 TELECOMMUNICATIONS
 SOUTH CAROLINA
 ISSUED: June 15, 2021
 BY: President - South Carolina
 Columbia, South Carolina

ACCESS SERVICES TARIFF

Thirteenth Revised Page 29
 Cancels Twelfth Revised Page 29

EFFECTIVE: June 30, 2021

E7. SPECIAL ACCESS (A.K.A. BELLSOUTH SPA) SERVICE**E7.4 Rate Regulations (Cont'd)****E7.4.1 Types of Rates and Charges (Cont'd)**

A. (Cont'd)

3. Service Rearrangements (Cont'd)

- Change of customer or customer's end user premises address when the change of address is not a result of a physical relocation of equipment,
- Change in billing data (name, address, or contact name or telephone number. The customer of record does not change.)
- Change of customer circuit identification,
- Change of billing account number,
- Change of customer test line number,
- Change of customer or customer's end user contact name or telephone number, and
- Change of jurisdiction.

All other service rearrangements, including physical changes to existing service, will be charged for as follows:

- If the change involves the addition of other customer designated premises to an existing multipoint service, the nonrecurring charge for the Local Channel rate element will apply. The charge(s) will apply only for the location(s) that is being added.

- If the change involves the addition of optional features or functions which have separate nonrecurring charges, the nonrecurring charges for the optional features or functions added will apply.

- If the change involves a customer requested change of data transmission rate for an existing Digital Data Access¹ (a.k.a. BellSouth SPA DS0 Digital Data) Service circuit, the appropriate nonrecurring charge shall be the Speed Change Charge provided in E7.5.5.C.4. following. This charge shall apply per local channel on each circuit where the speed is requested to be changed. The existing circuit will experience out of service time when the speed change work is conducted. (Full nonrecurring charges shall apply for customer requests for changes of data transmission rate where out of service time cannot be tolerated. The customer shall specify the disconnect date for the circuit being replaced.) (C)

- If the change involves changing the type of signaling on a Voice Grade¹ (a.k.a. BellSouth SPA DS0 VG) service, a charge equal to the Voice Grade¹ (a.k.a. BellSouth SPA DS0 VG) Local Channel rate element nonrecurring charge will apply. The charge will apply per service termination affected. (C)

- If the change involves changing (reconfiguring) an existing BellSouth Metro Ethernet service Connection, appropriate charges provided in E7.4.32 following apply.

- If the change involves the addition of a DS3 Network Interface Unit (NIU) to a SMARTRing service (a.k.a. BellSouth SPA Dedicated Ring) the rates and charges shown in E13.3.25.

- For all other changes, including a change of the customer of record involving no physical changes to the service provided or the addition of optional features without separate nonrecurring charges, a charge equal to a Local Channel rate element nonrecurring charge will apply. Only one such charge will apply per service, per change.

4. Transfer of Service

When a change in billing data (e.g., name, address, contact name, or telephone number) is requested in association with a change in the customer of record, transfer of service charges, as set forth in E7.5.13 following will apply. Charges are applied on a Billing Account Number (BAN) and per circuit basis.

E7.4.2 Surcharge for Special Access (a.k.a. BellSouth SPA) Service

A. General

In addition to the rates and charges described in E7.4.1. preceding, there is a monthly surcharge that applies to Special Access (a.k.a. BellSouth SPA) service. The Special Access (a.k.a. BellSouth SPA) Surcharge compensates the Company for use of the local exchange network when Special Access (a.k.a. BellSouth SPA) service is connected to a PBX or equivalent device which is capable of interconnecting the Special Access (a.k.a. BellSouth SPA) service with local exchange service.

The Company will automatically bill the surcharge on each Special Access (a.k.a. BellSouth SPA) service installed irrespective of whether the interconnection capability exists in the customer's premises equipment or in a Centrex Type Services switch unless written certification is received from the customer certifying exemption status as set forth in B. following.

Note 1: Effective June 30, 2021, this Service will no longer be available for purchase by new or existing customers. In addition, requests to move, add, change, or renew existing service arrangements will not be accepted. Following the expiration of a customer's existing term agreement, service will be provided on a month-to-month basis at the applicable Monthly rates until the service is discontinued. The Company currently plans to discontinue this service on or after June 30, 2024.

(N)
 |
 (N)

BELLSOUTH
TELECOMMUNICATIONS
SOUTH CAROLINA
ISSUED: June 15, 2021
BY: President - South Carolina
Columbia, South Carolina

ACCESS SERVICES TARIFF

Seventh Revised Page 32
Cancels Sixth Revised Page 32

EFFECTIVE: June 30, 2021

E7. SPECIAL ACCESS (A.K.A. BELLSOUTH SPA) SERVICE**E7.4 Rate Regulations (Cont'd)****E7.4.6 Mileage Measurement**

- A. The mileage to be used to determine the monthly rate for the Interoffice Channel is calculated on the airline distance between the locations involved i.e., the serving wire centers associated with two customer designated premises, a serving wire center associated with a customer designated premises and a Company hub, a serving wire center associated with a customer designated premises and a WATS serving office, or two Company hubs. The serving wire center associated with a customer designated premises is the serving wire center from which the customer designated premises would normally obtain dial tone.
- B. Mileage is shown in E7.5.2. following in terms of mileage bands. To determine the rate to be billed, first compute the mileage using the V and H coordinates method, as set forth in the National Exchange Carrier Association Tariff F.C.C. No. 4, then find the band into which the computed mileage falls and apply the rates shown for that band. When the calculation results in a fraction of a mile, always round up to the next whole mile before determining the mileage band and applying the rates.
- C. When Hubs are involved, mileage rates are computed and rates applied separately for each section of the Interoffice Channel, i.e., customer designated premises serving wire center to Hub, Hub to Hub and/or Hub to customer designated premises serving wire center. However, when any service is routed through a hub for purposes other than customer specified bridging or channelization (e.g., the Company chooses to so route for test access purposes), rates will be applied only to the distance calculated between the serving wire centers associated with the customer designated premises. For the purpose of applying multipoint charges, the bridging or hubbing locations are determined by that combination of airline distances connecting the serving wire center which will produce the lowest interoffice mileage charges.
- D. SMARTRing[®] service (a.k.a. BellSouth Dedicated Ring) Local Channel, Alternate Central Office Channel and Internodal Channel rates are also distance sensitive. They are measured per quarter airline mile or fraction thereof from the customer's designated premises to the Serving Wire Center, Alternate Central Office, or other Customer Nodes. V&H coordinates are derived for each customer location through the use of longitude and latitude measurements. Using the V&H coordinate method as set forth in the NATIONAL EXCHANGE CARRIER ASSOCIATION, INC. TARIFF FCC. No. 4, compute the mileage, convert to quarter miles, and multiply the appropriate per quarter mile rate by the distance involved. Any portion of a quarter mile will always round up to the next quarter mile before determining the mileage and applying the rate.
- E. The SMARTRing[®] service (a.k.a. BellSouth Dedicated Ring) Interoffice Channel mileage is calculated per quarter airline mile between two directly connected central offices on the ring. Interoffice Channel mileage is computed by using the V&H coordinates method as set forth in the NATIONAL EXCHANGE CARRIER ASSOCIATION, INC. TARIFF FCC. No. 4. To determine the rate to be billed, multiply the appropriate per quarter mile rate by the distance involved. Fractions of a quarter mile always round up to the next quarter mile before determining the mileage and applying the rate.

E7.4.7 Facility Hubs

A customer has the option of ordering Voice Grade² (a.k.a. BellSouth SPA DS0 VG) facilities or digital high capacity facilities (i.e., DS1, DS1C, DS2, or DS3) to a facility Hub for channelizing to individual services requiring lower capacity facilities (e.g., Telegraph² (a.k.a. BellSouth SPA Telegraph), Voice² (a.k.a. BellSouth SPA DS0 VG), Wired Music⁽¹⁾, etc.). (C)

Different locations may be designated as Hubs for different facility capacities, e.g., channelization from digital to digital may occur at one location while channelization from digital to analog may occur at a different location. When ordering, the customer will specify the desired channelization Hub(s) selected from the National Exchange Carrier Association Tariff F.C.C. No. 4. This tariff identifies the type(s) of channelization functions which are available and the serving wire centers at which they are available. (C)

Some of the types of channelization available include the following:

- from higher to lower bit rate
- from digital to voice frequency channels

End to end services may be provided on channels of these facilities to a hub. The transmission performance for the end to end service provided between customer designated premises will be that of the lower capacity or bit rate. For example, when a 1.544 Mbps facility is channelized to voice frequency channels, the transmission performance of the channelized services will be Voice Grade² (a.k.a. BellSouth SPA DS0 VG), not High Capacity (a.k.a. BellSouth SPA High Capacity). (C)

Note 1: Effective December 1, 2020, this Service will no longer be available for purchase by new or existing customers, and service agreements may no longer be renewed. In addition, requests to move, add, or change existing service arrangements will not be accepted. Following the expiration of a customer's existing term agreement, service will be provided on a month-to-month basis at the applicable month-to-month rates until the service is discontinued. AT&T currently plans to discontinue this Service on or after December 1, 2021.

Note 2: Effective June 30, 2021, this Service will no longer be available for purchase by new or existing customers. In addition, requests to move, add, change, or renew existing service arrangements will not be accepted. Following the expiration of a customer's existing term agreement, service will be provided on a month-to-month basis at the applicable Monthly rates until the service is discontinued. The Company currently plans to discontinue this service on or after June 30, 2024.

(N)
|
(N)

BELLSOUTH
TELECOMMUNICATIONS
SOUTH CAROLINA
ISSUED: June 15, 2021
BY: President - South Carolina
Columbia, South Carolina

ACCESS SERVICES TARIFF

Eleventh Revised Page 33
Cancels Tenth Revised Page 33

EFFECTIVE: June 30, 2021

E7. SPECIAL ACCESS (A.K.A. BELLSOUTH SPA) SERVICE

E7.4 Rate Regulations (Cont'd)

E7.4.7 Facility Hubs (Cont'd)

The Company will commence billing the monthly rate for the facility to the Hub on the date specified by the customer on the service order. Individual services utilizing these facilities may be installed coincident with the installation of the facility to the Hub or may be ordered and/or installed at a later date, at the option of the customer. The customer will be billed for a Voice Grade² (a.k.a. BellSouth SPA DS0 VG) or digital Local Channel, Interoffice Channel, Interoffice Channel, if applicable and the Basic Channelization System at the time the facility is installed. DS1 and DS0 Basic Channelization Systems² require a Central Office Channel Interface for activation of each lesser capacity channel. DS3 to DS1 channelization arrangements, for transport of intrastate DS1 service high capacity channels via LightGate (a.k.a. BellSouth SPA Point to Point Network) and SMARTRing services (a.k.a. BellSouth SPA Dedicated Ring), require a DS1 channel interface for activation of each DS1 channel. Individual service rates (by service type) will apply for a Local Channel, additional Interoffice Channel and Central Office Channel Interface(s) (as required), if applicable, for each channelized service. These will be billed to the customer as each individual service is installed.

Cascading channelization occurs when a high capacity analog or digital channel is channelized to provide channels with a lesser capacity and one of the lesser capacity channels is further channelized.

When cascading channelization is performed, whether in the same or a different Hub, a charge for the additional Basic Channelization System and Central Office Channel Interface(s) also applies. A DS1 Basic Channelization System and DDAS² (a.k.a. BellSouth SPA DS0 Digital Data) Central Office Channel Interface are required for high speed or low speed DDAS² (a.k.a. BellSouth SPA DS0 Digital Data) activations when channelized from a DS1 (1.544 Mbps) channel. A DS0 Basic Channelization System² and Subrate Central Office Channel Interface² are required for subrate² activations of 2.4, 4.8 and 9.6 Kbps when channelized from a DS0² (64 Kbps) channel. When cascading channelization is performed at different Hubbing locations, Interoffice Channel charges also apply between the Hubs.

Although not requiring channelization, the Company will designate certain hubs for Wired Music⁽¹⁾ services. A customer can order service(s) between customer designated premises and a hub and will be billed accordingly at the rates set forth in E7.5.4 and E7.5.5 following for the service, as appropriate. The customer will be charged for each such connection made at the rates for Other Labor as set forth in E13.2.5 following. The rates that apply for the service between each customer designated premises and the hub are a Local Channel and Interoffice Channel, if applicable. In addition, for Wired Music⁽¹⁾ services, rates for optional features and functions may be applicable.

E7.4.8 Shared Use Analog and Digital High Capacity (a.k.a. BellSouth SPA High Capacity) Services

Shared use occurs when Special Access (a.k.a. BellSouth SPA) service and BellSouth SWA are provided over the same High Capacity (a.k.a. BellSouth SPA High Capacity) facility through a common interface. When the IC orders Special Access (a.k.a. BellSouth SPA) service, the facility will be ordered and rated as Special Access (a.k.a. BellSouth SPA) service (i.e., Local Channel or Virtual Collocation Cross-Connect, Interoffice Channel, as appropriate, and Basic Channelization System, and Central Office Channel Interface(s), if applicable) until such time as the IC chooses to use a portion of the available capacity for providing BellSouth SWA. As each individual channel is activated for BellSouth SWA, the Special Access (a.k.a. BellSouth SPA) Local Channel rates, Interoffice Channel rates, and Basic Channelization System rates, if applicable, will be reduced accordingly (e.g., 1/24th for a DS1 service, etc.). The IC must place an order for each individual BellSouth SWA channel utilizing the Shared Use Facilities and specify the channel assignment for each such service. BellSouth SWA rates and charges as set forth in E6.8. preceding will apply for each channel of the shared use facility that is used to provide BellSouth SWA. Where Special Access (a.k.a. BellSouth SPA) service is provided utilizing a channel of the shared use facility to the hub, High Capacity (a.k.a. BellSouth SPA High Capacity) rates and charges will apply for the facility to the hub as set forth preceding and individual service rates and charges will apply from the hub to the IC designated premises. The rates and charges that will apply to the portion from the hub to the IC designated premises will be dependent on the specific type of Special Access (a.k.a. BellSouth SPA) service that is provided (e.g., Voice Grade² (a.k.a. BellSouth SPA DS0 VG), Telegraph² (a.k.a. BellSouth SPA Telegraph), etc.). The applicable rates and charges will include a Local Channel and Interoffice Channel, and appropriate channelization elements, if applicable.

Virtual Collocation Cross-Connects provide a means for customers to interconnect their BellSouth Shared Use and Digital High Capacity (a.k.a. BellSouth SPA High Capacity) services to Central Office Collocation arrangements *within the same Central Office*. *Terms, conditions, and rates for Physical Access Collocation Cross-Connects and Virtual Access Collocation Cross-Connects are set forth in Section E13. of this Tariff.*

Note 1: Effective December 1, 2020, this Service will no longer be available for purchase by new or existing customers, and service agreements may no longer be renewed. In addition, requests to move, add, or change existing service arrangements will not be accepted. Following the expiration of a customer's existing term agreement, service will be provided on a month-to-month basis at the applicable month-to-month rates until the service is discontinued. AT&T currently plans to discontinue this Service on or after December 1, 2021.

Note 2: Effective June 30, 2021, this Service will no longer be available for purchase by new or existing customers. In addition, requests to move, add, change, or renew existing service arrangements will not be accepted. Following the expiration of a customer's existing term agreement, service will be provided on a month-to-month basis at the applicable Monthly rates until the service is discontinued. The Company currently plans to discontinue this service on or after June 30, 2024.

(C)

(C)

(C)

(C)

(C)

(C)

(C)

(C)

(N)

(N)

BELLSOUTH
TELECOMMUNICATIONS
SOUTH CAROLINA
ISSUED: June 15, 2021
BY: President - South Carolina
Columbia, South Carolina

ACCESS SERVICES TARIFF

Second Revised Page 33.0.1
Cancels First Revised Page 33.0.1

EFFECTIVE: June 30, 2021

E7. SPECIAL ACCESS (A.K.A. BELLSOUTH SPA) SERVICE

E7.4 Rate Regulations (Cont'd)

E7.4.8 Shared Use Analog and Digital High Capacity (a.k.a. BellSouth SPA High Capacity) Services (Cont'd)

The capability exists for a customer to utilize all or part of a SMARTRing[®] service (a.k.a. BellSouth Dedicated Ring) to transport switched access provided the SMARTRing[®] service (a.k.a. BellSouth Dedicated Ring) channel interface transporting the BellSouth SWA service does not have FlexServ[®] service (a.k.a. BellSouth SPA Customer Reconfiguration) capability. The customer must place an order for each individual BellSouth SWA Channel provided over Dedicated Access service Shared Use Facilities and specify the channel assignment for each such service. The switched traffic would enter and exit the SMARTRing[®] service (a.k.a. BellSouth Dedicated Ring) at Customer and Central Office Nodes on that network. When this occurs, ratcheting of Dedicated Access rate elements (i.e. Nodes, Channel Interfaces, Local Channels, Alternate Central Office Channels, Internodal Channels, or Interoffice Channels) will be based on the number of voice grade¹ (a.k.a. BellSouth SPA DS0 VG) equivalent trunks/lines of that rate element used for BellSouth SWA access. (C)

Reduction factors will be developed to reduce the charges on system level billing as well as the billing on individual DS1, DS3, STS-1, OC-3, and/or OC-12 Channel Interfaces. For ratcheting purposes, the system level charges include Customer Nodes, Central Office Nodes, Local Channels, Alternate Central Office Channels, Internodal Channels, and Interoffice Channels as appropriate to make up a customer's SMARTRing[®] service (a.k.a. BellSouth Dedicated Ring). Individual OC-1, OC-3 and OC-12 Channel Interfaces used in Overlay Ring Arrangements will be ratcheted as system level charges. The system reduction factor will apply to the system level charges.

The system reduction factor will be derived by dividing the number of activated BellSouth SWA access circuits by the voice grade¹ (a.k.a. BellSouth SPA DS0 VG) channel equivalent capacity of the self-healing ring. An OC-1 SMARTRing[®] service (a.k.a. BellSouth Dedicated Ring) has 672 voice grade¹ (a.k.a. BellSouth SPA DS0 VG) equivalent channels. An OC-3 SMARTRing[®] service (a.k.a. BellSouth Dedicated Ring) has 2,016 voice grade¹ (a.k.a. BellSouth SPA DS0 VG) equivalent channels. An OC-3+ or OC-12 SMARTRing[®] service (a.k.a. BellSouth Dedicated Ring) has 8,064 voice grade¹ equivalent channels. An OC-48 SMARTRing[®] service (a.k.a. BellSouth Dedicated Ring) or OC-48+ SMARTRing[®] service (a.k.a. BellSouth Dedicated Ring) with 48 or less activated DS3s has 32,256 voice grade¹ (a.k.a. BellSouth SPA DS0 VG) equivalent channels. However, when an OC-48+ SMARTRing[®] service (a.k.a. BellSouth Dedicated Ring) is used to transport BellSouth SWA service, and more than 48 equivalent DS3s are activated on the service, the factor will be based upon the actual number of activated DS3s times 672 DS0s. A factor for individual DS3 channel interfaces and 28 DS1 channel systems, will be derived by dividing the number of activated BellSouth SWA access circuits associated with the DS3 channel by the voice grade¹ (a.k.a. BellSouth SPA DS0 VG) equivalent capacity of the DS3 channel. A DS3 has 672 voice grade¹ (a.k.a. BellSouth SPA DS0 VG) equivalent channels. For DS1 channel interfaces, a factor is derived by dividing the number of BellSouth SWA access circuits associated with the DS1 channel by the voice grade¹ (a.k.a. BellSouth SPA DS0 VG) equivalent capacity of the DS1 channel, which is 24. Each reduction factor is rounded to four decimal places and then multiplied against the respective monthly charges to determine the reduction amount. (C)

BellSouth SWA rates and charges as set forth in E6.8 preceding will apply for each channel of the shared use facility that is used to provide BellSouth SWA. (C)

E7.4.9 Multijurisdictional WATS Access Line¹ (a.k.a. BellSouth SPA WATS Line) "1+" and "0" IntraLATA Usage (C)

"1+" and "0" intraLATA usage carried over outward WATS Access Lines (a.k.a. BellSouth SPA WATS Line) from this Tariff, having both intra and interstate capability (multijurisdictional) and provided from the BellSouth Telecommunications, Inc. Tariff FCC No. 1 or other appropriate Local Exchange Carrier (LEC) interstate tariff, will be completed over LEC facilities at LEC intraLATA outward WATS rates and subject to rules and regulations applicable to LEC intraLATA outward WATS. Subscribers using a multijurisdictional access line for BellSouth SWA 8XX Toll Free Dialing Ten Digit Screening Service may choose either the Company or the interexchange carrier to complete and bill intraLATA calls according to the appropriate rates, rules and regulations. The "1+" and "0" intraLATA usage will be billed to the customer (end user or IC) where the closed end of the Multijurisdictional WATS Access Line (a.k.a. BellSouth SPA WATS Line) is terminated. Customer billing information must be provided to the Company at the time the Multijurisdictional WATS Access Line (a.k.a. BellSouth SPA WATS Line) is ordered when the Company is used to complete intraLATA calls.

E7.4.10 Reserved for Future Use

E7.4.11 Reserved for Future Use

Note 1: Effective June 30, 2021, this Service will no longer be available for purchase by new or existing customers. In addition, requests to move, add, change, or renew existing service arrangements will not be accepted. Following the expiration of a customer's existing term agreement, service will be provided on a month-to-month basis at the applicable Monthly rates until the service is discontinued. The Company currently plans to discontinue this service on or after June 30, 2024. (N)

Material appearing on this page previously appeared on page(s) 33 of this section.

® Registered Service Mark of BellSouth Intellectual Property Corporation

BELLSOUTH
TELECOMMUNICATIONS
SOUTH CAROLINA
ISSUED: June 15, 2021
BY: President - South Carolina
Columbia, South Carolina

ACCESS SERVICES TARIFF

Fifth Revised Page 33.4
Cancels Fourth Revised Page 33.4

EFFECTIVE: June 30, 2021

E7. SPECIAL ACCESS (A.K.A. BELLSOUTH SPA) SERVICE**E7.4 Rate Regulations (Cont'd)****E7.4.12 FlexServ® Service (a.k.a. BellSouth SPA Customer Reconfiguration) (Cont'd)**

- B. Application of Rates (Cont'd)
 - 2. FlexServ® service (a.k.a. BellSouth SPA Customer Reconfiguration) Options (Cont'd)
 - f. Reconfigurations by the Company Personnel

A nonrecurring charge is applicable on each occasion, when the customer requests Company personnel to perform a reconfiguration or a series of reconfigurations in order to set up point-to-point or multipoint connections, to provide a status report or to establish a conference.

E7.4.13 Derived Data Channel² (a.k.a. BellSouth SPA Derived Data Channel) Service (DDCS)

(C)

- A. Application of Rates

The derived data channel (a.k.a. BellSouth SPA Derived Data Channel) charges provide the central office data/voice multiplexing capability. The customer must also subscribe to a compatible two-wire local exchange line (e.g., business exchange line, ESSX® service main station line). This two-wire exchange line and its associated rates and charges are in addition to the derived data channel rates and charges.

The DS0-B interface charge is applicable for each group of a maximum of twenty multiplexed derived data channels. Each of the twenty channels in a DS0-B interface channel group operates at a bit rate of 2.4 Kbps. The interoffice channel is required when the customer's serving wire center and the serving wire center of the customer's terminating premises are not the same.

E7.4.14 Digital Data Access² (a.k.a. BellSouth SPA DS0 Digital Data) Service (DDAS)

(C)

- A. General

Digital Data Access (a.k.a. BellSouth SPA DS0 Digital Data) service is available on a month-to-month basis or under either of two optional contract plans.
- B. Application of Rates
 - 1. Digital Data Access (a.k.a. BellSouth SPA DS0 Digital Data) service is offered under two contract plans. Contract plan rates are available in payment periods from twenty-four to forty-two months¹ and in payment periods from forty-three to sixty months¹ under conditions specified in the Channel Services Payment Plan in E2.4 of this Tariff. These payment periods are an exception to those listed in E2.4 of this Tariff.

A Termination Liability Charge is applicable at the date of termination if the IC or end user terminates or disconnects the service prior to fulfilling the period of the contract plan, except as follows.

 - a. A Termination Liability Charge will not be applicable at the date of termination if the IC or end user terminates or disconnects the service prior to fulfilling the period of the contract plan for IC or end user requested changes to a higher order of service covered by the Channel Services Payment Plan as specified in E2.4.9.B.4.b, or IC or end user requested changes to services not covered by the Channel Services Payment Plan that are offered by the Company under a contract payment plan provided that applicable conditions set forth in E2.4.9.B.4.b. are satisfied.

Note 1: Effective May 1, 2019, Customers may not convert, renew or establish CSPPs for Digital Data Access Service

Note 2: Effective June 30, 2021, this Service will no longer be available for purchase by new or existing customers. In addition, requests to move, add, change, or renew existing service arrangements will not be accepted. Following the expiration of a customer's existing term agreement, service will be provided on a month-to-month basis at the applicable Monthly rates until the service is discontinued. The Company currently plans to discontinue this service on or after June 30, 2024.

(N)
|
(N)

BELLSOUTH
TELECOMMUNICATIONS
SOUTH CAROLINA
ISSUED: June 15, 2021
BY: President - South Carolina
Columbia, South Carolina

ACCESS SERVICES TARIFF

Sixth Revised Page 33.5
Cancels Fifth Revised Page 33.5

EFFECTIVE: June 30, 2021

E7. SPECIAL ACCESS (A.K.A. BELLSOUTH SPA) SERVICE**E7.4 Rate Regulations (Cont'd)****E7.4.14 Digital Data Access² (a.k.a. BellSouth SPA DS0 Digital Data) Service (DDAS) (Cont'd)**

(C)

B. Application of Rates (Cont'd)

1. (Cont'd)

- b. A Termination Liability Charge will not apply for IC or end user requests for moves of service under CSPP subject to the provisions set forth in E2.4.9.A.8. preceding.

The Termination Liability Charge is determined by multiplying the contracted monthly rate times the number of months in the contract plan, less the contracted monthly rate times the number of months the service has been installed, **multiplied by a factor. The factor is fifty percent (50%) for contracts that have been in effect twelve months or less, or twenty percent (20%) for contracts that have been in effect longer than twelve months.** An example is as follows:

- An IC or end user subscribes to Digital Data Access (a.k.a. BellSouth SPA DS0 Digital Data) service using the twenty-four to forty-two month payment plan¹. The actual duration of the contract plan is for thirty months. The subscriber terminates the service after twelve months. The total liability charge is thirty months times the monthly rate. The amount is then reduced to reflect the number of months the subscriber has had the service, which in this example is twelve months. Therefore, the Termination Liability Charge is **fifty percent (50%) of this amount** calculated as follows:

Termination Liability Charges = $.50 \times [(30 \text{ months} \times \text{monthly rate}) - (12 \text{ months} \times \text{monthly rate})]$

E7.4.15 Zone Pricing

High Capacity (a.k.a. BellSouth SPA DS1) service (1.544 Mbps) is organized into three pricing zones. Rate levels for the Local Channel, Interoffice Channel, and DS1 Basic Channelization will be billed in accordance with the pricing zone assignment of the serving wire center. The pricing zone assignment for each Company serving wire center is specified in the National Exchange Carrier Association (NECA) Tariff F.C.C. No. 4.

Interoffice Channel mileage that is divided between two serving wire centers in differently priced zones will be billed at the higher priced zone rate. Channelization rates will be determined by the location of the channelization arrangement.

Note 1: Effective May 1, 2019, Customers may not convert, renew or establish CSPPs for Digital Data Access Service.

Note 2: Effective June 30, 2021, this Service will no longer be available for purchase by new or existing customers. In addition, requests to move, add, change, or renew existing service arrangements will not be accepted. Following the expiration of a customer's existing term agreement, service will be provided on a month-to-month basis at the applicable Monthly rates until the service is discontinued. The Company currently plans to discontinue this service on or after June 30, 2024.

(N)

(N)

BELLSOUTH
 TELECOMMUNICATIONS
 SOUTH CAROLINA
 ISSUED: June 15, 2021
 BY: President - South Carolina
 Columbia, South Carolina

ACCESS SERVICES TARIFF

Sixth Revised Page 34
 Cancels Fifth Revised Page 34

EFFECTIVE: June 30, 2021

E7. SPECIAL ACCESS (A.K.A. BELLSOUTH SPA) SERVICE

E7.5 Rates And Charges

E7.5.1 Reserved for Future Use

E7.5.2 Telegraph Grade (a.k.a. BellSouth SPA Telegraph) Service^{1,2}

(C)

A. Local Channel

1. Per Point of Termination

	Monthly Rate	Nonrecurring Charge	USOC
(a) Two-Wire	\$24.00	\$-	T6E2X
(b) Four-Wire	48.00	-	T6E4X

B. Interoffice Channel

1. Mileage Bands

	Fixed Monthly Charge	Monthly Charge Per Mile	Nonrecurring Charge	USOC
(a) 0 miles	\$-	\$-	\$-	1L5XX
(b) 1 thru 8 miles	60.00	2.46	-	1L5XX
(c) 9 thru 25 miles	60.00	2.40	-	1L5XX
(d) Over 25 miles	60.00	2.34	-	1L5XX

Note 1: Telegraph Grade (a.k.a. BellSouth SPA Telegraph) service is not available for additions, new installations or moves of service.

Note 2: Effective June 30, 2021, this Service will no longer be available for purchase by new or existing customers. In addition, requests to move, add, change, or renew existing service arrangements will not be accepted. Following the expiration of a customer's existing term agreement, service will be provided on a month-to-month basis at the applicable Monthly rates until the service is discontinued. The Company currently plans to discontinue this service on or after June 30, 2024.

(N)
 |
 (N)

BELLSOUTH
 TELECOMMUNICATIONS
 SOUTH CAROLINA
 ISSUED: June 15, 2021
 BY: President - South Carolina
 Columbia, South Carolina

ACCESS SERVICES TARIFF

Seventh Revised Page 35
 Cancels Sixth Revised Page 35

EFFECTIVE: June 30, 2021

E7. SPECIAL ACCESS (A.K.A. BELLSOUTH SPA) SERVICE

E7.5 Rates And Charges (Cont'd)

E7.5.2 Telegraph Grade (a.k.a. BellSouth SPA Telegraph) Service^{1,3} (Cont'd) (C)

C. Optional Features and Functions

1. Telegraph Bridging

	Monthly Rate	Nonrecurring Charge	USOC
(a) Two-Wire, per port	\$3.60	\$-	BCNT2
(b) Four-Wire, per port	3.60	-	BCNT4

E7.5.3 Voice Grade³ (a.k.a. BellSouth SPA DS0 VG) Service (C)

A. Local Channel

1. Per Point of Termination

a. Voice Grade (a.k.a. BellSouth SPA DS0 VG)

(1) Voice

	Monthly Rate	Nonrecurring First Charge	Additional	USOC
(a) Two-Wire	\$42.00	\$330.00	\$132.00	T6E2X
(b) Four-Wire	66.00	336.00	138.00	T6E4X
(2) Data				
(a) Two-Wire	48.00	360.00	150.00	T6E2X
(b) Four-Wire	72.00	372.00	162.00	T6E4X
(3) Loop Facilities Not Required ²				
(a) Two-Wire	12.00	174.00	97.20	EUC2N
(b) Four-Wire	12.00	174.00	97.20	EUC4N

B. Interoffice Channel

1. Mileage Bands

	Fixed Monthly Charge		Nonrecurring Charge	USOC
	Monthly Charge	Per Mile	Charge	
(a) 0 mile	\$-	\$-	\$-	1L5XX
(b) 1 thru 8 miles	72.00	2.88	120.00	1L5XX
(c) 9 thru 25 miles	72.00	2.88	120.00	1L5XX
(d) Over 25 miles	72.00	2.88	120.00	1L5XX

Note 1: Telegraph Grade (a.k.a. BellSouth SPA Telegraph) service is not available for additions, new installations or moves of service.

Note 2: For connections to Company Centrex Type Services Switches and Equipment considered to be end user premises.

Note 3: Effective June 30, 2021, this Service will no longer be available for purchase by new or existing customers. In addition, requests to move, add, change, or renew existing service arrangements will not be accepted. Following the expiration of a customer's existing term agreement, service will be provided on a month-to-month basis at the applicable Monthly rates until the service is discontinued. The Company currently plans to discontinue this service on or after June 30, 2024.

(N)
 |
 (N)

BELLSOUTH
 TELECOMMUNICATIONS
 SOUTH CAROLINA
 ISSUED: June 15, 2021
 BY: President - South Carolina
 Columbia, South Carolina

ACCESS SERVICES TARIFF

Sixth Revised Page 36
 Cancels Fifth Revised Page 36

EFFECTIVE: June 30, 2021

E7. SPECIAL ACCESS (A.K.A. BELLSOUTH SPA) SERVICE

E7.5 Rates And Charges (Cont'd)

E7.5.3 Voice Grade¹ (a.k.a. BellSouth SPA DS0 VG) Service (Cont'd)

(C)

C. Optional Features and Functions

1. Bridging

a. Voice Bridging

(1) Per port

(a) Two-Wire

(b) Four-Wire

b. Data Bridging

(1) Per port

(a) Two-Wire

(b) Four-Wire

c. Telephoto Bridging

(1) Per port

(a) Two-Wire

(b) Four-Wire

	Monthly Rate	Nonrecurring Charge	USOC
(a) Two-Wire	<i>\$14.40</i>	<i>\$50.40</i>	BCNV2
(b) Four-Wire	<i>16.80</i>	<i>50.40</i>	BCNV4
(a) Two-Wire	<i>24.00</i>	<i>54.00</i>	BCND2
(b) Four-Wire	<i>24.00</i>	<i>54.00</i>	BCND4
(a) Two-Wire	<i>14.40</i>	<i>50.40</i>	BCNF2
(b) Four-Wire	<i>16.80</i>	<i>50.40</i>	BCNF4

Note 1: Effective June 30, 2021, this Service will no longer be available for purchase by new or existing customers. In addition, requests to move, add, change, or renew existing service arrangements will not be accepted. Following the expiration of a customer's existing term agreement, service will be provided on a month-to-month basis at the applicable Monthly rates until the service is discontinued. The Company currently plans to discontinue this service on or after June 30, 2024.

(N)

(N)

BELLSOUTH
 TELECOMMUNICATIONS
 SOUTH CAROLINA
 ISSUED: June 15, 2021
 BY: President - South Carolina
 Columbia, South Carolina

ACCESS SERVICES TARIFF

Seventh Revised Page 37
 Cancels Sixth Revised Page 37

EFFECTIVE: June 30, 2021

E7. SPECIAL ACCESS (A.K.A. BELLSOUTH SPA) SERVICE

E7.5 Rates And Charges (Cont'd)

E7.5.3 Voice Grade¹ (a.k.a. BellSouth SPA DS0 VG) Service (Cont'd)

(C)

C. Optional Features and Functions (Cont'd)

2. Conditioning, Per Point of Termination

	Monthly	Nonrecurring Charge		
	Rate	Initial	Subsequent	USOC
(a) C-Type	<i>\$3.60</i>	<i>\$18.00</i>	<i>\$112.80</i>	X1CPT
(b) Improved Attenuation Distortion	<i>102.00</i>	<i>98.40</i>	<i>204.00</i>	UHW
(c) Improved Envelope Delay Distortion	<i>144.00</i>	<i>98.40</i>	<i>204.00</i>	UHY
(d) Sealing Current	<i>1.20</i>	<i>49.20</i>	<i>138.00</i>	1HBPT
3. Echo Control For Effective Two-Wire Service				
(1) Per Point of Termination				
(a) Improved Return Loss at the Two-Wire Point of Termination	<i>24.00</i>	<i>8.40</i>	<i>342.00</i>	1RL2W
(b) ELEPL2 at the Four-Wire Point of Termination	<i>24.00</i>	<i>8.40</i>	<i>342.00</i>	UHZ
4. Customer Specified Receive Level				
(a) Per two-wire Point of Termination	<i>24.00</i>	<i>3.60</i>	<i>98.40</i>	RLS

Note 1: Effective June 30, 2021, this Service will no longer be available for purchase by new or existing customers. In addition, requests to move, add, change, or renew existing service arrangements will not be accepted. Following the expiration of a customer's existing term agreement, service will be provided on a month-to-month basis at the applicable Monthly rates until the service is discontinued. The Company currently plans to discontinue this service on or after June 30, 2024.

(N)

(N)

BELLSOUTH
 TELECOMMUNICATIONS
 SOUTH CAROLINA
 ISSUED: June 15, 2021
 BY: President - South Carolina
 Columbia, South Carolina

ACCESS SERVICES TARIFF

Ninth Revised Page 38
 Cancels Eighth Revised Page 38

EFFECTIVE: June 30, 2021

E7. SPECIAL ACCESS (A.K.A. BELLSOUTH SPA) SERVICE

E7.5 Rates And Charges (Cont'd)

E7.5.3 Voice Grade⁵ (a.k.a. BellSouth SPA DS0 VG) Service (Cont'd)

(C)

C. Optional Features and Functions (Cont'd)

5. D-Conditioning

		Monthly	Nonrecurring Charge		USOC
		Rate	Initial	Subsequent	
	(a) Per Point of Termination	\$3.60	\$10.80	\$378.00	XDCPT
6.	Telephoto Conditioning				
	(a) Per Point of Termination	3.60	3.60	336.00	XTCPT
7.	Signaling Capability, per Point of Termination				
	(a) Loop ¹	7.20	20.40	354.00	XSS++
	(b) Single Frequency	8.40	31.20	366.00	XSSSF
	(c) E&M ²	12.00	32.40	366.00	XSS++
	(d) Ground ³	7.20	13.20	348.00	XSS++
	(e) Type C	3.60	19.20	354.00	XSSLC
	(f) Other ⁴	7.20	25.20	360.00	XSS++
8.	Improved Termination				
	(a) Per Point of Termination	3.60	3.60	342.00	UGD
9.	Simplex Reversal				
	(a) Per Point of Termination	-	3.60	115.20	UGJ

Note 1: In lieu of ++ substitute LO or LS as appropriate.

Note 2: In lieu of ++ substitute EA, EB, EC or CT as appropriate.

Note 3: In lieu of ++ substitute GO or GS as appropriate.

Note 4: In lieu of ++ substitute LA, LB, LR, RV, DX, DY, EX, AB or AC as appropriate.

Note 5: Effective June 30, 2021, this Service will no longer be available for purchase by new or existing customers. In addition, requests to move, add, change, or renew existing service arrangements will not be accepted. Following the expiration of a customer's existing term agreement, service will be provided on a month-to-month basis at the applicable Monthly rates until the service is discontinued. The Company currently plans to discontinue this service on or after June 30, 2024.

(N)

(N)

BELLSOUTH
 TELECOMMUNICATIONS
 SOUTH CAROLINA
 ISSUED: June 15, 2021
 BY: President - South Carolina
 Columbia, South Carolina

ACCESS SERVICES TARIFF

Fourth Revised Page 38.1
 Cancels Third Revised Page 38.1

EFFECTIVE: June 30, 2021

E7. SPECIAL ACCESS (A.K.A. BELLSOUTH SPA) SERVICE

E7.5 Rates And Charges (Cont'd)

E7.5.3 Voice Grade² (a.k.a. BellSouth SPA DS0 VG) Service (Cont'd)

(C)

D. WATS Access Line² (a.k.a. BellSouth SPA WATS Line)

(C)

The following apply to a WATS Access Line (a.k.a. BellSouth SPA WATS Line) used for interLATA only calling. Rates for all other WATS Access Lines (a.k.a. BellSouth SPA WATS Line) (i.e., combined interLATA/intraLATA calling) are found in the General Subscriber Service Tariff, Section A19.

1. Two-Wire/Four-Wire WATS Access Line (a.k.a. BellSouth SPA WATS Line)
 - a. Local Channels

- (1) Per Point of Termination

	Monthly Rate	Nonrecurring Charge		
		First	Additional	USOC
(a) Per Two-Wire Line	<i>\$42.00</i>	<i>\$330.00</i>	<i>\$132.00</i>	X2W
(b) Per Two-Wire Line ¹	<i>42.00</i>	<i>330.00</i>	<i>132.00</i>	X2L
(c) Per Four-Wire Line	<i>66.00</i>	<i>336.00</i>	<i>138.00</i>	X4W
(d) Per Four-Wire Line ¹	<i>66.00</i>	<i>336.00</i>	<i>138.00</i>	X4L

Note 1: For use with Direct Inward Dial (DID) or DID/DOD Access Service with BellSouth SWA Basic Serving Arrangement for use with Dedicated Access Lines described in E6.3.5.A. and provided in E6.8.3.A.6. of this Tariff.

Note 2: Effective June 30, 2021, this Service will no longer be available for purchase by new or existing customers. In addition, requests to move, add, change, or renew existing service arrangements will not be accepted. Following the expiration of a customer's existing term agreement, service will be provided on a month-to-month basis at the applicable Monthly rates until the service is discontinued. The Company currently plans to discontinue this service on or after June 30, 2024.

(N)

(N)

BELLSOUTH
 TELECOMMUNICATIONS
 SOUTH CAROLINA
 ISSUED: June 15, 2021
 BY: President - South Carolina
 Columbia, South Carolina

ACCESS SERVICES TARIFF

Seventh Revised Page 39
 Cancels Sixth Revised Page 39

EFFECTIVE: June 30, 2021

E7. SPECIAL ACCESS (A.K.A. BELLSOUTH SPA) SERVICE

E7.5 Rates And Charges (Cont'd)

E7.5.3 Voice Grade⁽²⁾ (a.k.a. BellSouth SPA DS0 VG) Service (Cont'd)

(C)

D. WATS Access Line⁽²⁾ (a.k.a. BellSouth SPA WATS Line) (Cont'd)

(C)

- 2. Interoffice Channel
 - a. Mileage Bands
 - (1) Fixed Rate

		Fixed Monthly Charge			
		Monthly Charge	Per Mile	Nonrecurring Charge	USOC
(a)	0 mile	\$-	\$-	\$-	1LFFX
(b)	1 thru 8 miles	72.00	2.88	120.00	1LFFX
(c)	9 thru 25 miles	72.00	2.88	120.00	1LFFX
(d)	Over 25 miles	72.00	2.88	120.00	1LFFX

- 3. Optional Features
 - a. Improved Two-Wire Voice Transmission Specifications
 - (1) For WATS Access Line (a.k.a. BellSouth SPA WATS Line)

		Monthly Rate	Nonrecurring Charge		USOC
			Initial	Subsequent	
(a)	Two-Wire	\$24.00	\$46.80	\$105.60	X2T

- b. WATS Access Line Bridging
 - (1) Per port

		Monthly Rate	Nonrecurring Charge		USOC
			First	Additional	
(a)	Two-Wire	\$14.40	\$50.40		BCNV2
(b)	Four-Wire	16.80	50.40		BCNV4

E7.5.4 Wired Music⁽¹⁾ Service

- A. Local Channel
 - 1. Per Point of Termination

		Monthly Rate	Nonrecurring Charge		USOC
			First	Additional	
(a)	200 to 3500 Hz	\$42.00	\$624.00	\$270.00	T6ECS
(b)	100 to 5000 Hz	54.00	726.00	354.00	T6ECS
(c)	50 to 8000 Hz	60.00	744.00	372.00	T6ECS

(1) Effective December 1, 2020, this Service will no longer be available for purchase by new or existing customers, and service agreements may no longer be renewed. In addition, requests to move, add, or change existing service arrangements will not be accepted. Following the expiration of a customer's existing term agreement, service will be provided on a month-to-month basis at the applicable month-to-month rates until the service is discontinued. AT&T currently plans to discontinue this Service on or after December 1, 2021.

(2) Effective June 30, 2021, this Service will no longer be available for purchase by new or existing customers. In addition, requests to move, add, change, or renew existing service arrangements will not be accepted. Following the expiration of a customer's existing term agreement, service will be provided on a month-to-month basis at the applicable Monthly rates until the service is discontinued. The Company currently plans to discontinue this service on or after June 30, 2024.

(N)
 |
 (N)

BELLSOUTH
 TELECOMMUNICATIONS
 SOUTH CAROLINA
 ISSUED: June 15, 2021
 BY: President - South Carolina
 Columbia, South Carolina

ACCESS SERVICES TARIFF

Eighth Revised Page 41
 Cancels Seventh Revised Page 41

EFFECTIVE: June 30, 2021

E7. SPECIAL ACCESS (A.K.A. BELLSOUTH SPA) SERVICE

E7.5 Rates And Charges (Cont'd)

E7.5.5 Digital Data Access² (a.k.a. BellSouth SPA DS0 Digital Data) Service

(C)

A. Local Channel

1. Per Point of Termination

		Monthly Rate	24 to 42 Months ¹	43 to 60 Months ¹	Nonrecurring Charge		USOC
					First	Add'l	
(a)	2.4 Kbps	\$55.00	\$49.00	\$47.00	\$415.00	\$135.00	T6ECS
(b)	4.8 Kbps	55.00	49.00	47.00	415.00	135.00	T6ECS
(c)	9.6 Kbps	55.00	49.00	47.00	415.00	135.00	T6ECS
(d)	19.2 Kbps	55.00	49.00	47.00	415.00	135.00	T6ECS
(e)	56.0 Kbps	75.00	65.00	60.00	415.00	135.00	T6ECS
(f)	64.0 Kbps	75.00	65.00	60.00	415.00	135.00	T6ECS

2. Hub Termination, per Local Channel

(a)	2.4 Kbps	12.00	11.75	11.50	61.00	41.00	TUTA4
(b)	4.8 Kbps	12.00	11.75	11.50	61.00	41.00	TUTB4
(c)	9.6 Kbps	12.00	11.75	11.50	61.00	41.00	TUTC4
(d)	19.2 Kbps	12.00	11.75	11.50	61.00	41.00	TUTE4
(e)	56.0 Kbps	30.00	28.00	26.00	61.00	41.00	TUTD4
(f)	64.0 Kbps	30.00	28.00	26.00	61.00	41.00	TUTF4

B. Interoffice Channel

1. Fixed monthly rates, each channel 0 miles

		Monthly Rate	24 to 42 Months ¹	43 to 60 Months ¹	Nonrecurring Charge		USOC
					First	Add'l	
(a)	2.4, 4.8, 9.6 and 19.2 Kbps	\$-	\$-	\$-	\$-	\$-	1L5XX
(b)	56.0 and 64.0 Kbps	-	-	-	-	-	1L5XX

2. Each mile or fraction thereof, each channel 0 miles

(a)	2.4, 4.8, 9.6 and 19.2 Kbps	-	-	-	-	-	1L5XX
(b)	56.0 and 64.0 Kbps	-	-	-	-	-	1L5XX

3. Fixed monthly rates, each channel 1-8 miles

(a)	2.4, 4.8, 9.6 and 19.2 Kbps	20.00	19.50	19.00	66.00		1L5XX
(b)	56.0 and 64.0 Kbps	40.00	36.00	34.00	66.00		1L5XX

4. Each mile or fraction thereof, each channel 1-8 miles

(a)	2.4, 4.8, 9.6 and 19.2 Kbps	2.05	1.90	1.75	-		1L5XX
(b)	56.0 and 64.0 Kbps	4.10	3.80	3.10	-		1L5XX

5. Fixed monthly rates, each channel 9-25 miles

(a)	2.4, 4.8, 9.6 and 19.2 Kbps	20.00	19.50	19.00	66.00		1L5XX
(b)	56.0 and 64.0 Kbps	40.00	36.00	34.00	66.00		1L5XX

Note 1: Effective May 1, 2019, Customers may not convert, renew or establish CSPPs for Digital Data Access Service.

Note 2: Effective June 30, 2021, this Service will no longer be available for purchase by new or existing customers. In addition, requests to move, add, change, or renew existing service arrangements will not be accepted. Following the expiration of a customer's existing term agreement, service will be provided on a month-to-month basis at the applicable Monthly rates until the service is discontinued. The Company currently plans to discontinue this service on or after June 30, 2024.

(N)
 |
 (N)

BELLSOUTH
 TELECOMMUNICATIONS
 SOUTH CAROLINA
 ISSUED: June 15, 2021
 BY: President - South Carolina
 Columbia, South Carolina

ACCESS SERVICES TARIFF

Fourth Revised Page 41.1
 Cancels Third Revised Page 41.1

EFFECTIVE: June 30, 2021

E7. SPECIAL ACCESS (A.K.A.BELLSOUTH SPA) SERVICE

E7.5 Rates And Charges (Cont'd)

E7.5.5 Digital Data Access² (a.k.a. BellSouth SPA DS0 Digital Data) Service (Cont'd)

(C)

B. Interoffice Channel (Cont'd)

- 6. Each mile or fraction thereof, 9-25 miles

		Monthly	24 to 42	43 to 60	Nonrecurring	
		Rate	Months¹	Months¹	Charge	USOC
(a)	2.4, 4.8, 9.6 and 19.2 Kbps	\$2.00	\$1.85	\$1.70	\$-	1L5XX
(b)	56.0 and 64.0 Kbps	4.00	3.70	3.00	-	1L5XX
7.	Fixed monthly rates, each channel over 25 miles					
(a)	2.4, 4.8, 9.6 and 19.2 Kbps	20.00	19.50	19.00	66.00	1L5XX
(b)	56.0 and 64.0 Kbps	40.00	36.00	34.00	66.00	1L5XX

Note 1: Effective May 1, 2019, Customers may not convert, renew or establish CSPPs for Digital Data Access Service.

Note 2: Effective June 30, 2021, this Service will no longer be available for purchase by new or existing customers. In addition, requests to move, add, change, or renew existing service arrangements will not be accepted. Following the expiration of a customer's existing term agreement, service will be provided on a month-to-month basis at the applicable Monthly rates until the service is discontinued. The Company currently plans to discontinue this service on or after June 30, 2024.

(N)

(N)

BELLSOUTH
 TELECOMMUNICATIONS
 SOUTH CAROLINA
 ISSUED: June 15, 2021
 BY: President - South Carolina
 Columbia, South Carolina

ACCESS SERVICES TARIFF

Eleventh Revised Page 42
 Cancels Tenth Revised Page 42

EFFECTIVE: June 30, 2021

E7. SPECIAL ACCESS (A.K.A. BELLSOUTH SPA) SERVICE

E7.5 Rates And Charges (Cont'd)

E7.5.5 Digital Data Access⁴ (a.k.a. BellSouth SPA DS0 Digital Data) Service (Cont'd)

(C)

B. Interoffice Channel (Cont'd)

- 8. Each mile or fraction thereof, each channel over 25 miles

		Monthly Rate	24 to 42 Months³	43 to 60 Months³	Nonrecurring Charge	USOC
(a)	2.4, 4.8, 9.6 and 19.2 Kbps	\$1.95	\$1.80	\$1.65	\$-	1L5XX
(b)	56.0 and 64.0 Kbps	3.90	3.60	2.90	-	1L5XX

C. Optional Features and Functions

- 1. Bridging^{1,2}

(a)	Per Port	25.00	24.00	22.00	23.00	BCNDA
-----	----------	--------------	--------------	--------------	--------------	--------------

- 2. Digital Data Secondary Channel Capability, per Local Channel^{1,2}

		Monthly Rate	24 to 42 Months	43 to 60 Months	Nonrecurring Charge	USOC
					Initial Subsequent	
(a)	Each	\$15.00	\$14.00	\$13.00	\$- \$240.00	SFS

Note 1: Not available at all service locations

Note 2: This option is not available with 64.0 Kbps.

Note 3: Effective May 1, 2019, Customers may not convert, renew or establish CSPPs for Digital Data Access Service.

Note 4: Effective June 30, 2021, this Service will no longer be available for purchase by new or existing customers. In addition, requests to move, add, change, or renew existing service arrangements will not be accepted. Following the expiration of a customer's existing term agreement, service will be provided on a month-to-month basis at the applicable Monthly rates until the service is discontinued. The Company currently plans to discontinue this service on or after June 30, 2024.

(N)

(N)

BELLSOUTH
 TELECOMMUNICATIONS
 SOUTH CAROLINA
 ISSUED: June 15, 2021
 BY: President - South Carolina
 Columbia, South Carolina

ACCESS SERVICES TARIFF

Eighth Revised Page 42.1
 Cancels Seventh Revised Page 42.1

EFFECTIVE: June 30, 2021

E7. SPECIAL ACCESS SERVICE

E7.5 Rates And Charges (Cont'd)

E7.5.5 Digital Data Access³ Service (Cont'd)

(C)

C. Optional Features and Functions (Cont'd)

3.

4. Speed Change Charge¹

(a) Per Local Channel

Nonrecurring Charge		USOC
First	Additional	
\$330.00	\$170.00	SCH

E7.5.6 High Capacity Service

A. Local Channel

1. Per Point of Termination - 1.544 Mbps

	Monthly Rate		Nonrecurring Charge		USOC
	Minimum	Maximum	First	Additional	
SEE CURRENT PRICE LIST					
(a) Rate Zone 1	\$120.00	\$200.00	\$675.00	\$310.00	TMECS
(b) Rate Zone 2	120.00	200.00	675.00	310.00	TMECS
(c) Rate Zone 3	120.00	200.00	675.00	310.00	TMECS

2. Per Point of Termination

(a) 3.152 Mbps ²	-	-	-	-	TWT++
(b) 6.312 Mbps ²	-	-	-	-	TWT++
(c) 44.736 Mbps ²	-	-	-	-	TWT++

Note 1: Speed Change Charge is applicable where circuit out of service time during speed change activity is acceptable to customer.

Note 2: ICB rates and charges apply.

Note 3: Effective June 30, 2021, this Service will no longer be available for purchase by new or existing customers. In addition, requests to move, add, change, or renew existing service arrangements will not be accepted. Following the expiration of a customer's existing term agreement, service will be provided on a month-to-month basis at the applicable Monthly rates until the service is discontinued. The Company currently plans to discontinue this service on or after June 30, 2024.

(N)

(N)

BELLSOUTH
 TELECOMMUNICATIONS
 SOUTH CAROLINA
 ISSUED: June 15, 2021
 BY: President - South Carolina
 Columbia, South Carolina

ACCESS SERVICES TARIFF

Tenth Revised Page 45
 Cancels Ninth Revised Page 45

EFFECTIVE: June 30, 2021

E7. SPECIAL ACCESS (A.K.A. BELLSOUTH SPA) SERVICE

E7.5 Rates And Charges (Cont'd)

E7.5.6 High Capacity (a.k.a. BellSouth SPA High Capacity) Service (Cont'd)

- C. Optional Features and Functions
 - 1. Channelization

	Nonrecurring Charge	Monthly Rate		USOC
		SEE CURRENT PRICE LIST Minimum	SEE CURRENT PRICE LIST Maximum	
a. DS3 Channelization				
(1) DS3 to DS1				
(a) Per arrangement ¹	\$-	\$-	\$-	MXB++
b. DS2 Channelization				
(1) DS2 to DS1				
(a) Per arrangement ¹	-	-	-	MXD++
c. DS1C Channelization				
(1) DS1C to DS1				
(a) Per arrangement ¹	-	-	-	MXH++
d. DS1 Channelization				
(1) DS1 Basic Channelization System (DS1 to VG/DS0)				
(a) Rate Zone 1 - Per System	130.00	158.00	263.00	MQ1
(b) Rate Zone 2 - Per System	130.00	158.00	263.00	MQ1
(c) Rate Zone 3 - Per System	130.00	158.00	263.00	MQ1
e. DS0 Channelization ²				
(1) DS0 Basic Channelization System (DS0 to Subrates)				
(Per System)				
(a) Maximum of 20 2.4 Kbps services	130.00	90.00	150.00	QSU24
(b) Maximum of 10 2.4 Kbps services	130.00	90.00	150.00	QSU48
(c) Maximum of 5 9.6 Kbps services	130.00	90.00	150.00	QSU96

Note 1: ICB rates and charges apply.

Note 2: Effective June 30, 2021, this Service will no longer be available for purchase by new or existing customers. In addition, requests to move, add, change, or renew existing service arrangements will not be accepted. Following the expiration of a customer's existing term agreement, service will be provided on a month-to-month basis at the applicable Monthly rates until the service is discontinued. The Company currently plans to discontinue this service on or after June 30, 2024.

(C)

(N)
 |
 (N)

BELLSOUTH
 TELECOMMUNICATIONS
 SOUTH CAROLINA
 ISSUED: June 15, 2021
 BY: President - South Carolina
 Columbia, South Carolina

ACCESS SERVICES TARIFF

Eighth Revised Page 45.1
 Cancels Seventh Revised Page 45.1

EFFECTIVE: June 30, 2021

E7. SPECIAL ACCESS (A.K.A. BELLSOUTH SPA) SERVICE

E7.5 Rates And Charges (Cont'd)

E7.5.6 High Capacity (a.k.a. BellSouth SPA High Capacity) Service (Cont'd)

- C. Optional Features and Functions (Cont'd)
 - 2. Channel Interfaces (Per Interface)
 - a. Sub-DS3 Interfaces
 - DS1 Level Central Office Channel Interface

	Recurring Rate SEE CURRENT PRICE LIST		Nonrecurring Charge	USOC
	Minimum	Maximum		
(1) Asynchronous				
(a) Month-To-Month	\$9.00	\$15.00	\$155.00	1D3CA
(b) 24-48 Months ¹	6.00	10.00	155.00	1D3CA
(c) 49-72 Months ¹	5.00	9.00	155.00	1D3CA
(d) 73-96 Months ¹	4.00	8.00	155.00	1D3CA
(2) Synchronous				
(a) Month-To-Month	\$27.00	\$45.00	\$130.00	1D3CS
(b) 24-48 Months ¹	23.00	39.00	130.00	1D3CS
(c) 49-72 Months ¹	21.00	35.00	130.00	1D3CS
(d) 73-96 Months ¹	19.00	31.00	130.00	1D3CS
b. Sub-DS3 Interfaces				
DS1 Level Customer Channel Interface				
(1) Asynchronous				
(a) Month-To-Month	\$13.00	\$21.00	\$310.00	1D3DA
(b) 24-48 Months ⁽¹⁾	10.00	16.00	310.00	1D3DA
(c) 49-72 Months ⁽¹⁾	10.00	16.00	310.00	1D3DA
(d) 73-96 Months ⁽¹⁾	10.00	16.00	310.00	1D3DA
(2) Synchronous				
(a) Month-To-Month	\$34.00	\$56.00	\$250.00	1D3DS
(b) 24-48 Months ⁽¹⁾	27.00	45.00	250.00	1D3DS
(c) 49-72 Months ⁽¹⁾	25.00	41.00	250.00	1D3DS
(d) 73-96 Months ⁽¹⁾	23.00	38.00	250.00	1D3DS
c. Sub-DS1 Interfaces				
(1) VG/DS0 Level Central Office Channel Interface				

	Recurring Rate SEE CURRENT PRICE LIST		Nonrecurring Charge		USOC
	Minimum	Maximum	First	Additional	
(a) <i>BellSouth SWA</i>	\$0.00	\$0.00	\$0.00	\$0.00	1D1SW
(b) Telegraph ³ (a.k.a. <i>BellSouth SPA Telegraph</i>)	4.00	6.00	7.00	6.00	1D1TE (C)
(c) Voice Grade ³ (a.k.a. <i>BellSouth SPA DSO VG</i>)	5.00	8.00	7.00	6.00	1D1VG (C)
(d) WATS Access Line ³ (a.k.a. <i>BellSouth SPA WATS Line</i>)	5.00	8.00	7.00	6.00	1D1WT (C)
(e) Wired Music ⁽²⁾ - monthly	30.00	45.00	7.00	6.00	1D1PA
(f) Wired Music ⁽²⁾ - daily	3.00	5.00	7.00	6.00	1D1PA
(g) DDAS ³ (a.k.a. <i>BellSouth SPA DSO Digital Data</i>)	11.00	16.00	7.00	6.00	1D1DD (C)

Note 1: Effective May 1, 2019, Customers may not: (1) Establish CSPPs greater than 36 months for High Capacity Service, and (2) Convert or renew CSPPs for High Capacity Service.

Note 2: Effective December 1, 2020, this Service will no longer be available for purchase by new or existing customers, and service agreements may no longer be renewed. In addition, requests to move, add, or change existing service arrangements will not be accepted. Following the expiration of a customer's existing term agreement, service will be provided on a month-to-month basis at the applicable month-to-month rates until the service is discontinued. AT&T currently plans to discontinue this Service on or after December 1, 2021.

Note 3: Effective June 30, 2021, this Service will no longer be available for purchase by new or existing customers. In addition, requests to move, add, change, or renew existing service arrangements will not be accepted. Following the expiration of a customer's existing term agreement, service will be provided on a month-to-month basis at the applicable Monthly rates until the service is discontinued. The Company currently plans to discontinue this service on or after June 30, 2024.

(N)
 |
 (N)

BELLSOUTH
 TELECOMMUNICATIONS
 SOUTH CAROLINA
 ISSUED: June 15, 2021
 BY: President - South Carolina
 Columbia, South Carolina

ACCESS SERVICES TARIFF

Seventh Revised Page 45.2
 Cancels Sixth Revised Page 45.2

EFFECTIVE: June 30, 2021

E7. SPECIAL ACCESS (A.K.A. BELLSOUTH SPA) SERVICE

E7.5 Rates And Charges (Cont'd)

E7.5.6 High Capacity (a.k.a. BellSouth SPA High Capacity) Service (Cont'd)

- C. Optional Features and Functions (Cont'd)
 - 2. Channel Interfaces (Per Interface) (Cont'd)
 - d. Sub-DS0 Interfaces¹
 - (1) Subrate Level Central Office Channel Interface

(C)

		Recurring Rate		Nonrecurring		
		SEE CURRENT PRICE LIST		Charge		
		Minimum	Maximum	First	Additional	USOC
3.	(a) Subrate (2.4, 4.8, & 9.6 Kbps)	\$11.00	\$16.00	\$7.00	\$6.00	1DOSR

- 4. Clear Channel Capability is furnished on a per DS1 service channel basis. Per DS1/1.544 Mbps High Capacity Channel optioned as:

		Monthly	Nonrecurring Charge		
		Rate	Initial	Subsequent	
	(a) Superframe Format (SF)	\$0.00	\$-	\$605.00	CCOSF
	(b) Extended Superframe Format (ESF)	0.00	-	605.00	CCOEF
5.	(DELETED)				

Note 1: Effective June 30, 2021, this Service will no longer be available for purchase by new or existing customers. In addition, requests to move, add, change, or renew existing service arrangements will not be accepted. Following the expiration of a customer's existing term agreement, service will be provided on a month-to-month basis at the applicable Monthly rates until the service is discontinued. The Company currently plans to discontinue this service on or after June 30, 2024.

(N)

(N)

BELLSOUTH
TELECOMMUNICATIONS
SOUTH CAROLINA
ISSUED: June 15, 2021
BY: President - South Carolina
Columbia, South Carolina

ACCESS SERVICES TARIFF

Sixth Revised Page 46.2
Cancels Fifth Revised Page 46.2

EFFECTIVE: June 30, 2021

E7. SPECIAL ACCESS (A.K.A. BELLSOUTH SPA) SERVICE**E7.5 Rates And Charges (Cont'd)****E7.5.15 Derived Data Channel² (a.k.a. BellSouth SPA Derived Data Channel) service****A. Local Channel**

1. Derived Data Channel (a.k.a. BellSouth SPA Derived Data Channel)

	Nonrecurring Charge	Month To Month	24 to 42 Months ¹	43 to 60 Months ¹	USOC
(a) Per channel at 2.4 Kbps	\$450.00	\$17.00	\$13.50	\$11.00	DAXPG

2. DS0-B Interface

(a) Per group of twenty channels at 2.4 Kbps each	330.00	70.00	65.00	62.00	DAXP1
---	--------	-------	-------	-------	-------

B. Interoffice Channel

1. Per group of twenty channels at 2.4 Kbps each

(a) Fixed	90.00	25.00	23.00	22.00	DAXPF
(b) Per mile	-	2.05	1.90	1.75	DAXPM

E7.5.16 FlexServ Service (a.k.a. BellSouth SPA Customer Reconfiguration)**A. Basic FlexServ service (a.k.a. BellSouth SPA Customer Reconfiguration)**

1. DS0 Channel Connections

	Nonrecurring Charge	Month To Month	24 to 48 Months ¹	49 to 72 Months ¹	73 to 96 Months ¹	USOC
(a) Voice Grade Type, per DS0 channel	\$35.00	\$14.90	\$13.70	\$12.70	\$11.90	DSLVA
(b) Digital Type, per DS0 channel	35.00	8.50	7.80	7.25	6.80	DSLDA

2. DS1 Channel Connections

(a) DS0 Switching, per DS1 channel	125.00	110.00	100.00	92.00	85.00	DSL1A
(b) DS1 Switching, per DS1 channel	125.00	65.00	60.00	55.00	52.00	DSL1B
(c) Surveillance - DS1 Level per DS1 channel	125.00	65.00	60.00	55.00	52.00	DSL1S

3. DS3 Channel Connections

(a) Surveillance - DS1 Level, per DS3 channel	125.00	375.00	345.00	320.00	300.00	DSL3S
(b) Surveillance - DS3 Level, per DS3 channel	125.00	150.00	138.00	128.00	120.00	DSL3T

B. FlexServ service (a.k.a. BellSouth SPA Customer Reconfiguration) Options

1. Multipoint Bridging

(a) Voice Grade Connections, per bridging leg	20.00	5.00	4.50	4.40	4.30	FSSF9
(b) Multipoint Junction Unit, per 2.4, 4.8, 9.6 or 56 Kbps channel (must purchase in units of 5)	15.00	6.00	5.25	5.00	4.75	FSSFJ
(c) Multipoint Junction Unit, per 19.2 Kbps channel (must purchase in units of 5)	15.00	9.45	8.90	8.40	7.90	FSSF9

Note 1: Effective May 1, 2019, Customers may not convert, renew or establish CSPPs for Derived Data Channel Service and FlexServ Service.

Note 2: Effective June 30, 2021, this Service will no longer be available for purchase by new or existing customers. In addition, requests to move, add, change, or renew existing service arrangements will not be accepted. Following the expiration of a customer's existing term agreement, service will be provided on a month-to-month basis at the applicable Monthly rates until the service is discontinued. The Company currently plans to discontinue this service on or after June 30, 2024.

(C)

(N)

(N)