

Access Service Tariff

Cause No. PUD 200500456
Order No. 514693
Tracking No.

3rd Revised Sheet 15-1
Replacing 2nd Revised Sheet 15-1

ACCESS SERVICE

	<u>Sheet</u>
15. Network Management Services	15-2
15.1 Network Reconfiguration Service	15-2
15.1.1 General	15-2
15.1.2 Network Reconfiguration Options	15-2
15.1.3 Network Reconfiguration Functions	15-3
(A) Routing/Rerouting	15-3
(B) Renaming	15-3
(C) Special Day Definition	15-3
(D) Resource Verification	15-3
(E) Transaction Log	15-3
(F) Multi-Level Security	15-3
(G) Compatibility Table	15-3
(H) Path Priority	15-3
(I) Reservation Summary Screen	15-3
(J) Simple Commands and Screens	15-4
(K) MACRO Command/Network Modeling	15-5
(L) Variable Bandwidth	15-6
15.1.4 Technical Specifications	15-4
15.1.5 Rate Regulations	15-4
(A) Rate Element Descriptions	15-4
(B) Application of Rates	15-6
(C) Service configurations	15-7
15.1.6 Rates and Charges	15-8
(A) Service Establishment Charge	15-8
(B) Database Modification Charge	15-8
(C) Port Charges	15-8
(D) Reconfigurations Charges	15-8
15.2 This Section of the Access Service Tariff is being removed in its entirety.	

Access Service Tariff

Cause No. PUD
Order No.
Tracking No. OK-18-0058

3rd Revised Sheet 15-2
Replacing 2nd Revised Sheet 15-2

ACCESS SERVICE

15. Network Management Services

The following list matches the Telephone Company's Basic Service Element (BSE) names to the industry standard names for each BSE.

<u>Telephone Company Names</u>	<u>Generic Name of ONA Service</u>
Network Reconfiguration	Network Reconfiguration

15.1 Network Reconfiguration Service¹ (AT)

15.1.1 General

Network Reconfiguration Service is a BSE that permits customers to access a database maintained by the Telephone Company to reconfigure their dedicated network. Customers gain database access through the use of a terminal on their premises without going through normal service order procedures.

Network Reconfiguration Service allows customers direct access to, and control of, their 45 Mbps services, 1.544 Mbps services, subtending channels, and Internodal Facilities (the facilities that connect a Digital Cross-Connect System in one central office with a Digital Cross-Connect System in another central office) without going through normal service order procedures. Network Reconfiguration Service utilizes a central office cross-connect system for the remote reconfiguration of these channels. Customers can reconfigure their dedicated service network from their premises, or they can have the Telephone Company perform the reconfigurations.

Customers will access Network Reconfiguration Service by using a terminal on their premises in conjunction with dedicated lines provided for in Sections 7 and 20, or in conjunction with a local telephone line with a seven digit telephone number.

Network Reconfiguration Service is available at those Hubs where Telephone Company cross-connect systems are located. Network Reconfiguration Hub designations are found in the National Exchange Carrier Association, Inc. Tariff F.C.C. No. 4.

15.1.2 Network Reconfiguration Options

Two network reconfiguration options are available to Network Reconfiguration customers:
- On-demand
- Reservation

The on-demand option will make immediate changes to the network, while the reservation option will be executed at a specified time designated by the customer. Both types of reconfigurations are available whether the customer performs the reconfigurations or requests the Telephone Company to perform them.

¹ Effective December 7, 2018, Network Reconfiguration Service (NRS) will no longer be available for purchase by new or existing customers, and NRS service agreements may no longer be renewed. Effective July 31, 2022, the Telephone Company will no longer accept new requests for physical changes to existing service arrangements including the upgrade or downgrade of access/port speed, installation of new service, or moves to different service addresses. (AT)
(AT)

Access Service Tariff

Cause No. PUD
Order No.
Tracking No. OK-18-0058

3rd Revised Sheet 15-3
Replacing 2nd Revised Sheet 15-3

ACCESS SERVICE

15. Network Management Services (cont'd)

15.1 Network Reconfiguration Service¹ (cont'd)

(AT)

15.1.3 Network Reconfiguration Functions

Network Reconfiguration Service provides the following functions:

- (A) Routing/Rerouting
The routing feature allows customers to select the routes that will be used to connect their circuits between DCSs. The route selection process can be controlled by various parameters according to the customer's needs. Rerouting of circuits off of a failed internodal facility to a working one is also available.
- (B) Renaming
Renaming permits customers to rename their network locations, circuits, and facilities.
- (C) Special Day Definition
Special day definition gives customers the capability to specify circuit reconfiguration on special days, e.g., payday, holidays.
- (D) Resource Verification
Resource verification allows customers to verify the resource availability for the reservation period in their reconfiguration request prior to the system's confirmation or denial of the request.
- (E) Transaction Log
Transaction log provides customers a database log that contains every transaction involving reconfigurations.
- (F) Multi-Level Security
Multi-level security eliminates the unauthorized entry into a customer's circuit network arrangement inventory.
- (G) Compatibility Table
Compatibility table permits customers to view the allowable access line combinations that can be used with Network Reconfiguration Service.
- (H) Path Priority
Path priority gives customers the ability to arrange their circuit paths in order of priority when multiple routes exist.
- (I) Reservation Summary Screen
Reservation summary screen allows customers to view the status of their reconfiguration reservations.

¹ Effective December 7, 2018, Network Reconfiguration Service (NRS) will no longer be available for purchase by new or existing customers, and NRS service agreements may no longer be renewed. Effective July 31, 2022, the Telephone Company will no longer accept new requests for physical changes to existing service arrangements including the upgrade or downgrade of access/port speed, installation of new service, or moves to different service addresses.

(AT)
|
(AT)

ACCESS SERVICE

15. Network Management Services (cont'd)

15.1 Network Reconfiguration Service¹ (cont'd) (AT)

15.1.3 Network Reconfiguration Functions (cont'd)

- (J) Simple Commands and Screens
Simple commands and screens permits customers to use simple commands on screens with easy to use menus.
- (K) MACRO Command/Network Modeling
MACRO command/network modeling (i.e., model request) gives customers the ability to initiate, with one command, multiple two-point cross-connections. Customers can build separate network models, such as daytime models, nighttime models, and disaster recovery models and invoke their activation or switch from one to the other.
- (L) Variable Bandwidth
Variable bandwidth applies to an Internodal Facility and permits it to be used interchangeably to connect full 45 Mbps or 1.544 Mbps services, or to connect one or more individual subtending channels.

15.1.4 Technical Specifications

Services that are cross-connected by Network Reconfiguration Service must have identical technical characteristics to ensure compatibility and proper operations, e.g., Data to Data, Voice to Voice.

Network Reconfiguration Service specifications are delineated in Technical Reference TR-TSY-000366.

15.1.5 Rate Regulations

This section contains information related to the rate elements applicable to Network Reconfiguration Service. Rates and charges associated with the rate elements are listed in 15.3.1.

(A) Rate Element Descriptions

(1) Service Establishment Charge

The Service Establishment charge applies per customer database setup. The customer database setup is a grid, built by the Telephone Company, that contains all the circuits the customer will be able to control and reconfigure. Security, as well as circuit inventory, is built into the grid, permitting the customer control of its own circuits. Also included is the provisioning of customer training. This charge includes the connection of the initial circuits.

¹ Effective December 7, 2018, Network Reconfiguration Service (NRS) will no longer be available for purchase by new or existing customers, and NRS service agreements may no longer be renewed. Effective July 31, 2022, the Telephone Company will no longer accept new requests for physical changes to existing service arrangements including the upgrade or downgrade of access/port speed, installation of new service, or moves to different service addresses. (AT)

Access Service Tariff

Cause No. PUD
Order No.
Tracking No. OK-18-0058

3rd Revised Sheet 15-5
Replacing 2nd Revised Sheet 15-5

ACCESS SERVICE

15. Network Management Services (cont'd)

15.1 Network Reconfiguration Service¹ (cont'd)

(AT)

15.1.5 Rate Regulations (cont'd)

(A) Rate Element Descriptions (cont'd)

(2) Database Modification Charge

This charge applies (per customer contact, or request) each time the customer requests a subsequent modification of its database. A modification can be an addition or deletion of circuits terminating on the cross-connect system, or a rearrangement of the database, e.g., an outside move, a change in the signaling characteristics of a circuit (e.g., from data to voice), a rearrangement of the customer's routing priority between nodes, virtual port establishment, etc.

(3) Port Charges

Port Charges apply per port termination on the cross-connect system. There are three types of charges:

- Subtending Port Charge - applies per subtending channel port termination for all Special Access services (64 Kbps and below or 45 Mbps service) per circuit on the cross-connect system.
- 1.544 Mbps Port Charge - applies for 128 kbps - 1.544 Mbps channel port termination per circuit on the cross-connect system.
- 45 Mbps Port Charge - applies for 45 Mbps channel port termination per circuit on the cross-connect system.

Two Port Charges apply per circuit connecting 2 Network Reconfiguration Hubs or 2 cross-connect systems within the same Network Reconfiguration Hub (with one Port Charge applying at each termination of the circuit).

(4) Reconfiguration Charges

Full 45 Mbps or 1.544 Mbps bandwidth, sub 45 Mbps or 1.544 Mbps bandwidth, contiguous subtending channel groupings (up to and including all 24 subtending channels within a 1.544 Mbps service), contiguous 1.544 Mbps service groupings (up to and including all 28 1.544 Mbps services within a 45 Mbps service), or individual subtending channel or 1.544 Mbps service arrangements are as specified by the customer. This specification limits the parameters within which the service can be reconfigured and defines how reconfiguration charges will apply. If reconfiguration is at the subtending channel, 1.544 Mbps or 45 Mbps level, one reconfiguration charge applies per subtending channel, 1.544 Mbps service or 45 Mbps circuit reconfigured; if reconfiguration is for a previously defined contiguous group of subtending channels, one reconfiguration charge applies per group of DS0s reconfigured; etc. One reconfiguration charge applies per cross-connect and/or disconnect successfully completed in a DCS per request.

¹ Effective December 7, 2018, Network Reconfiguration Service (NRS) will no longer be available for purchase by new or existing customers, and NRS service agreements may no longer be renewed. Effective July 31, 2022, the Telephone Company will no longer accept new requests for physical changes to existing service arrangements including the upgrade or downgrade of access/port speed, installation of new service, or moves to different service addresses.

(AT)

(AT)

Access Service Tariff

Cause No. PUD
Order No.
Tracking No. OK-18-0058

3rd Revised Sheet 15-6
Replacing 2nd Revised Sheet 15-6

ACCESS SERVICE

15. Network Management Services (cont'd)

15.1 Network Reconfiguration Service¹ (cont'd)

(AT)

15.1.5 Rate Regulations (cont'd)

(A) Rate Element Descriptions (cont'd)

(4) Reconfiguration Charges (cont'd)

There are two types of reconfiguration charges:

- For individual reservation or demand request performed by the customer, or for each segment of a model request performed by the customer or Telephone Company.
- For individual reservation or demand requests performed by the Telephone Company at the customer's request.

For example, if a customer wishes to reconfigure a circuit that is routed through two NRS Hub offices (the existing circuit being routed between customer premises A through the two NRS Hub offices to customer premises B, and the customer wishes to reconfigure the circuit to be rerouted between customer premises A through the two NRS Hub offices to customer premises C), two transactions would occur: one transaction to disconnect the circuit between premises A and B, and one transaction to reconnect the circuit between premises A and C. The customer would be billed four NRS charges: two for disconnecting the circuit (one for each disconnect at each NRS Hub), and two for reconnecting the circuit (one for each reconnect at each NRS Hub).

(B) Application of Rates

When Network Reconfiguration Service is used in conjunction with Special Access services, the appropriate regulations, rates and charges as set forth in Section 7 will apply in addition to charges as set forth in 15.3.1:

- One Channel Termination (CT) applies between the customer premises and serving wire center.
- Channel Mileage or Interoffice Mileage, if applicable, applies between the serving wire center and the Telephone Company Network Reconfiguration Hub, or between two Network Reconfiguration Hubs.

Nonrecurring charges, as set forth in Section 7, are also applicable when existing channels must be reterminated in a Network Reconfiguration Port to provide Network Reconfiguration Service.

¹ Effective December 7, 2018, Network Reconfiguration Service (NRS) will no longer be available for purchase by new or existing customers, and NRS service agreements may no longer be renewed. Effective July 31, 2022, the Telephone Company will no longer accept new requests for physical changes to existing service arrangements including the upgrade or downgrade of access/port speed, installation of new service, or moves to different service addresses.

(AT)

(AT)

Access Service Tariff

Cause No. PUD
Order No.
Tracking No. OK-18-0058

3rd Revised Sheet 15-7
 Replacing 2nd Revised Sheet 15-7

ACCESS SERVICE

15. Network Management Services (cont'd)

15.1 Network Reconfiguration Service¹ (cont'd)

(AT)

15.1.5 Rate Regulations (cont'd)

(C) Service Configurations

- (1) The following diagram depicts a typical Network Reconfiguration Network with its applicable rate elements:

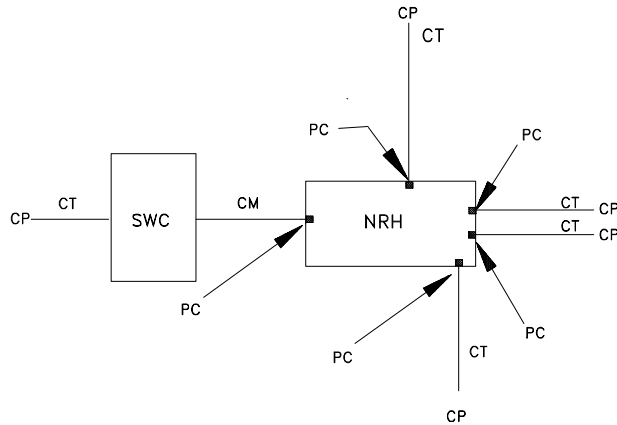

- (2) The following diagram depicts a Network Reconfiguration utilizing two Network Reconfiguration Hubs:

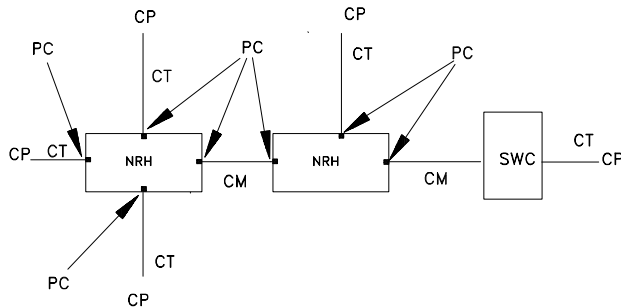

CM = Channel Mileage
 CP = Customer Premises
 CT = Channel Termination
 NRH = Network Reconfiguration Hub
 PC = Port Charge
 SWC = Serving Wire Center

¹ Effective December 7, 2018, Network Reconfiguration Service (NRS) will no longer be available for purchase by new or existing customers, and NRS service agreements may no longer be renewed. Effective July 31, 2022, the Telephone Company will no longer accept new requests for physical changes to existing service arrangements including the upgrade or downgrade of access/port speed, installation of new service, or moves to different service addresses.

(AT)

(AT)

Access Service Tariff

Cause No. PUD
Order No.
Tracking No. OK-18-0058

3rd Revised Sheet 15-8
 Replacing 2nd Revised Sheet 15-8

ACCESS SERVICE

15. Network Management Services (cont'd)

15.1 Network Reconfiguration Service¹ (cont'd) (AT)

15.1.6 Rates and Charges

	<u>USOC</u>	<u>Monthly Rate</u>	<u>Nonrecurring Charge</u>
(A) Service Establishment Charge per Database Setup	FN6DD	---	\$1,690.00
(B) Database Modification Charge per Request.....	FN6DC	---	86.00
(C) Port Charges Per Port Termination			
(1) Subtending Channel Port.....	PT5	\$8.00	9.00
(2) 1.544 Mbps Port.....	PT6	39.00	50.00
(3) 45 Mbps Port.....	D3D	395.00	75.00
(D) Reconfiguration Charges Per Cross-Connect and/or Disconnect successfully completed			
(1) Individual Reservation or Demand Request Performed by the customer; or each segment of a model request performed by customer or Telephone Company		---	.50
(2) Individual Reservation or Demand Request Performed by the Telephone Company at the customer's request		---	11.00

15.2 This section of the Access Service Tariff is being removed in its entirety.

¹ Effective December 7, 2018, Network Reconfiguration Service (NRS) will no longer be available for purchase by new or existing customers, and NRS service agreements may no longer be renewed. Effective July 31, 2022, the Telephone Company will no longer accept new requests for physical changes to existing service arrangements including the upgrade or downgrade of access/port speed, installation of new service, or moves to different service addresses. (AT)