

TARIFF DISTRIBUTION

FILE PACKAGE NO.: MO-21-0033

DATE: August 5, 2021

STATE: MISSOURI

EFFECTIVE DATE: 06/30/2021

TYPE OF DISTRIBUTION: Approved

PURPOSE: Grandfather Metallic, Telegraph, Voice Grade,
WATS, and MegaLink Data Services effective
6/30/21 with targeted sunset 6/30/24.

<u>TARIFF SECTION</u>	<u>PAGE NUMBER</u>	<u>PAGE REVISION</u>
E007	1	0008
E007	1.1	0005
E007	2	0006
E007	3	0005
E007	4	0006
E007	6	0010
E007	7	0002
E007	9	0003
E007	9.1	0003
E007	9.2	0001
E007	11	0007
E007	12	0009
E007	14	0010
E007	15	0003
E007	16	0004
E007	17	0004
E007	18	0003
E007	19	0007
E007	20	0005
E007	21	0004
E007	22	0006
E007	23	0005
E007	24	0004
E007	25	0005
E007	26	0005
E007	27	0006
E007	28	0004
E007	35	0009
E007	36	0007
E007	36.1	0005

E007	37	0013
E007	38	0007
E007	40	0007
E007	41	0008
E007	69	0009
E007	69.1	0004
E007	71	0006
E007	73	0006
E007	74	0004
E007	75.1	0003
E007	75.2	0002
E007	75.6	0003
E007	75.7	0003
E007	75.8	0003
E007	75.9	0003
E007	76	0006
E007	77	0006
E007	78	0006
E007	78.1	0006
E007	79	0006
E007	80	0006
E007	81	0007
E007	82	0007
E007	83	0007
E007	84	0006
E007	93	0007
E007	94	0005
E007	95	0009
E007	96	0005
E007	96.1	0001
E007	96.2	0001
E007	97	0008
E007	100	0006
E007	101	0006
E007	106	0002

P.S.C. Mo. - No. 36
ACCESS SERVICES TARIFF

Southwestern Bell Telephone
Company d/b/a AT&T Missouri

Section 7
8th Revised Sheet 1
Replacing 7th Revised Sheet 1

ACCESS SERVICES

7. SPECIAL ACCESS SERVICE

The following list matches the Telephone Company's Basic Service Element (BSE) names to the industry standard names for each BSE.

<u>Telephone Company Names</u>	<u>Generic Name of ONA Service</u>
Bridging	Bridging
- Central Office Bridging Capability - Telegraph(1) Bridging	(CP)
Clear Channel Capability on 1.544 Mbps	Access To Clear Channel Transmission
Conditioning	Conditioning
Extended Superframe Format	Extended Superframe Conditioning
Multiplexing	Multiplexing - Digital
- Central Office Multiplexing	
Secondary Channel Capability	Secondary Channel Capability

(1) Effective June 30, 2021, this Service will no longer be available for purchase by new or existing customers. In addition, requests to move, add, change, or renew existing service arrangements will not be accepted. Following the expiration of a customer's existing term agreement, service will be provided on a month-to-month basis at the applicable Monthly rates until the service is discontinued. The Company currently plans to discontinue this service on or after June 30, 2024. (AT)

(AT)

ACCESS SERVICES

7. SPECIAL ACCESS SERVICE

7.1 General

Special Access Service with the exception of the WATS Access Line(2) and Network Reconfiguration Service, provides a transmission path to connect customer (IC) designated premises (1), either directly or through a Telephone Company Hub where bridging, multiplexing, Network Reconfiguration Service or Frame Relay Service functions are performed. The WATS Access Line(2), offered under Voice Grade(2) Service, provides a transmission path connecting a customer designated premises with the WATS serving office. Network Reconfiguration Service found in Section 19, following, work in conjunction with Special Access Service allowing customers the ability to reconfigure their circuits. Frame Relay Service is found in Section 16. Special Access Service includes all exchange access not utilizing Telephone Company end-office switches. (CP)

The connections provided by Special Access Service can be either analog or digital. Analog connections are differentiated by spectrum and bandwidth. Digital connections are differentiated by bit rate. (CP)

7.1.1 Channel Types

There are nine types of channels used to provide Special Access Services. Each type has its own characteristics. All are subdivided by one or more of the following:

- Transmission specifications,
- Bandwidth,
- Speed (i.e., bit rate),
- Spectrum.

Customers can order a basic channel and select from a list of available transmission parameters and channel interfaces, those that they desire to meet specific communications requirements.

- (1) Telephone Company Centrex CO-like switches and Telephone Company Answering Service concentrators are considered to be customer premises for purposes of administering regulations and rates contained in this Tariff.
- (2) Effective June 30, 2021, this Service will no longer be available for purchase by new or existing customers. In addition, requests to move, add, change, or renew existing service arrangements will not be accepted. Following the expiration of a customer's existing term agreement, service will be provided on a month-to-month basis at the applicable Monthly rates until the service is discontinued. The Company currently plans to discontinue this service on or after June 30, 2024. (AT)

P.S.C. Mo. - No. 36
ACCESS SERVICES TARIFF

Southwestern Bell Telephone
Company d/b/a AT&T Missouri

Section 7
6th Revised Sheet 2
Replacing 5th Revised Sheet 2

ACCESS SERVICES

7. SPECIAL ACCESS SERVICE-(Continued)

7.1 General-(Continued)

7.1.1 Channel Types-(Continued)

For purposes of ordering channels, each has been identified as a type of Special Access Service. However, such identification is not intended to limit a customer's use of the channel nor to imply that the channel is limited to a particular use. For example, if a customer's equipment is capable of transmitting voice over a channel that is identified as a Metallic(1) Service in this Tariff, there is no restriction against doing so. (CP)

Following is a brief description of each type of channel:

Metallic(1) - A channel for the transmission of low-speed, varying signals at rates up to 30 baud. (CP)

Telegraph Grade(1) - A channel for the transmission of binary signals at rates of 0 to 75 baud or 0 to 150 baud. (CP)

Voice Grade(1) - A channel for the transmission of analog signals within an approximate bandwidth of 300-3000 Hz. (CP)

(RT)

(RT)

MegaLink Data(1) - A channel for the digital transmission of synchronous serial data at rates of 2.4, 4.8, 9.6 or 56.0 kbps. 56 kbps MegaLink Data channels are also provided in conjunction with Frame Relay Service. (CP)

High Capacity - A channel for the transmission of isochronous serial digital data at rates of 1.544, or 44.736 Mbps. High Capacity (1.544 Mbps) channels are also provided in conjunction with Frame Relay Service.

(1) Effective June 30, 2021, this Service will no longer be available for purchase by new or existing customers. In addition, requests to move, add, change, or renew existing service arrangements will not be accepted. Following the expiration of a customer's existing term agreement, service will be provided on a month-to-month basis at the applicable Monthly rates until the service is discontinued. The Company currently plans to discontinue this service on or after June 30, 2024. (AT)

(AT)

ACCESS SERVICES

7. SPECIAL ACCESS SERVICE-(Continued)

7.1 General-(Continued)

7.1.1 Channel Types-(Continued)

Detailed descriptions of each of the channel types are provided in Paragraph 7.2, following.

The customer also has the option of ordering Voice Grade(1) and analog and digital high capacity facilities (i.e., Group, Supergroup, Mastergroup, 1.544 Mbps, 3.152 Mbps, 6.312 Mbps, 44.736 Mbps and 274.176 Mbps) to a Telephone Company Hub for multiplexing to individual channels of a lower capacity or bandwidth. Descriptions of the types of multiplexing available at the Hubs, as well as the number of individual channels which may be derived from each type of facility are set forth in Paragraph 7.2, following. (CP)

Additionally, the customer may specify optional features or BSEs for the individual channels derived from the facility to further tailor the channel to meet specific communications requirements. Descriptions of the optional features, BSEs and functions available are also set forth in Paragraph 7.2, following.

For example, a customer may order a 3.152 Mbps facility from a customer-designated premises to a Telephone Company Hub for multiplexing to two 1.544 Mbps channels. The 1.544 Mbps channels may be further multiplexed at the same or a different Hub to Voice Grade(1) (i.e., Group level) channels or may be extended to other customer designated premises. Optional features and BSEs may be added to either the 1.544 Mbps or Voice Grade(1) channels. (CP)

7.1.2 Rate Categories

There are four basic rate categories which apply to Special Access Service:

- Channel Terminations (described in Paragraph 7.1.2, A., following)
- Channel Mileage (described in Paragraph 7.1.2, B., following)
- Service to Service Through Connect Arrangements (described in Paragraph 7.1.2, C., following)
- Optional Features, BSEs and Functions (described in Paragraph 7.1.2, D., following)

- (1) Effective June 30, 2021, this Service will no longer be available for purchase by new or existing customers. In addition, requests to move, add, change, or renew existing service arrangements will not be accepted. Following the expiration of a customer's existing term agreement, service will be provided on a month-to-month basis at the applicable Monthly rates until the service is discontinued. The Company currently plans to discontinue this service on or after June 30, 2024. (AT)

ACCESS SERVICES

7. SPECIAL ACCESS SERVICE-(Continued)

7.1 General-(Continued)

7.1.2 Rate Categories-(Continued)

A. Channel Termination

The Channel Termination rate category provides for the communications path between a customer designated premises and the serving wire center of that premises or for the communications path within a building which connects a customer's facilities with a customer designated premises without routing through the serving wire center. Included as part of the Channel Termination is a standard channel interface arrangement which defines the technical characteristics associated with the type of facilities to which the access service is to be connected at the Point of Termination (POT) and the type of signaling capability, if any. The signaling capability itself is provided as an optional feature as set forth in Paragraph D., following. One Channel Termination Charge applies per customer designated premises at which the channel is terminated. This charge will apply even if the customer designated premises and the serving wire center are both located in the same Telephone Company building.

B. Channel Mileage

The Channel Mileage rate category provides for the transmission facilities between the serving wire centers associated with two customer designated premises, between a serving wire center associated with a customer designated premises and a Telephone Company Hub, between two Telephone Company Hubs, or between a serving wire center associated with a customer designated premises and the WATS serving office. Channel mileage is portrayed in mileage bands. There are two rates that apply for each band, i.e., a flat rate per band and a rate per mile.

C. Service to Service Through Connect Arrangement

The Service to Service Through Connect Arrangement rate category provides for an interconnection of like services in a Telephone Company Hub or serving wire center as appropriate. This arrangement is an intraoffice connection that is provisioned in lieu of a channel termination to a customer designated premises. The through connection is provided in conjunction with Voice Grade(1) Analog, MegaLink Data(1) and High Capacity services. Additional Channel Mileage would apply if two like services are located in different Hubs or serving wire centers. The customer billed for the through connect arrangement will be responsible for all billing associated with the interconnection. (CP)

- (1) Effective June 30, 2021, this Service will no longer be available for purchase by new or existing customers. In addition, requests to move, add, change, or renew existing service arrangements will not be accepted. Following the expiration of a customer's existing term agreement, service will be provided on a month-to-month basis at the applicable Monthly rates until the service is discontinued. The Company currently plans to discontinue this service on or after June 30, 2024. (AT)

ACCESS SERVICES

7. SPECIAL ACCESS SERVICE

7.1 General (cont'd)

7.1.3 Service Configurations

There are four types of service configurations over which Special Access Services are provided: two-point service, multipoint service, WATS Access Line Service(1) and Service to Service Through Connect Arrangement. (CP)

A. Two-Point Service

A two-point service connects two customer-designated premises, either on a directly connected basis or through a Hub where multiplexing or Network Reconfiguration Service functions are performed. Applicable rate elements are:

- Channel Terminations
- Channel Mileage (as applicable)
- Optional Features, BSEs and Functions (when applicable)

In addition, a Special Access Surcharge as set forth in Paragraph 7.3.2, following, and a Message Station Equipment Recovery Charge as set forth in Paragraph 7.3.3, following, and/or an Inside Wire Recovery Charge as set forth in Paragraph 7.3.9, following, may be applicable.

- (1) Effective June 30, 2021, this Service will no longer be available for purchase by new or existing customers. In addition, requests to move, add, change, or renew existing service arrangements will not be accepted. Following the expiration of a customer's existing term agreement, service will be provided on a month-to-month basis at the applicable Monthly rates until the service is discontinued. The Company currently plans to discontinue this service on or after June 30, 2024.

(AT)
|
(AT)

ACCESS SERVICES

7. SPECIAL ACCESS SERVICE-(Continued)

7.1 General-(Continued)

7.1.3 Service Configurations-(Continued)

A. Two-Point Service-(Continued)

The following diagram depicts a two-point Voice Grade(1) Service connecting two customer designated premises located 15 miles apart. The service is provided with C-Type conditioning. (CP)

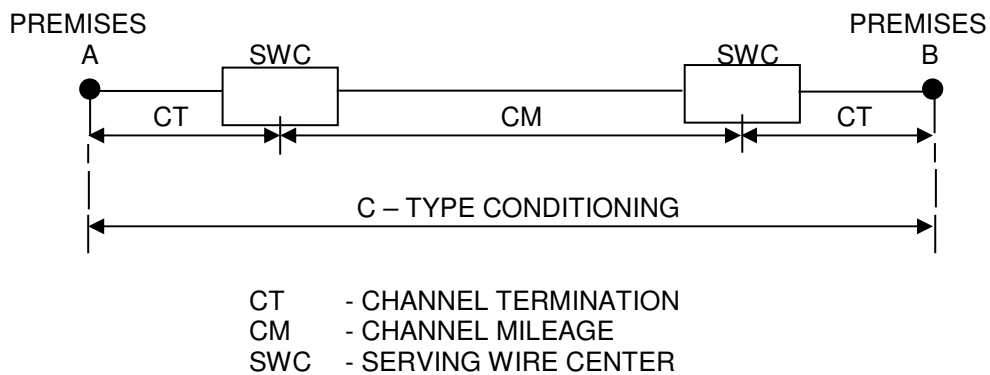

Applicable rate elements are:

- Channel Terminations (2 applicable)
- Channel Mileage (mileage band over 8 to 25 miles)
- C-Type Conditioning Optional Feature (1 per Channel Termination)

(1) Effective June 30, 2021, this Service will no longer be available for purchase by new or existing customers. In addition, requests to move, add, change, or renew existing service arrangements will not be accepted. Following the expiration of a customer's existing term agreement, service will be provided on a month-to-month basis at the applicable Monthly rates until the service is discontinued. The Company currently plans to discontinue this service on or after June 30, 2024. (AT)

ACCESS SERVICES

7. SPECIAL ACCESS SERVICE-(Continued)

7.1 General-(Continued)

7.1.3 Service Configurations-(Continued)

B. Multipoint Service-(Continued)

Example: Voice Grade(1) multipoint service connecting four customer premises via two customer designated bridging hubs. (CP)

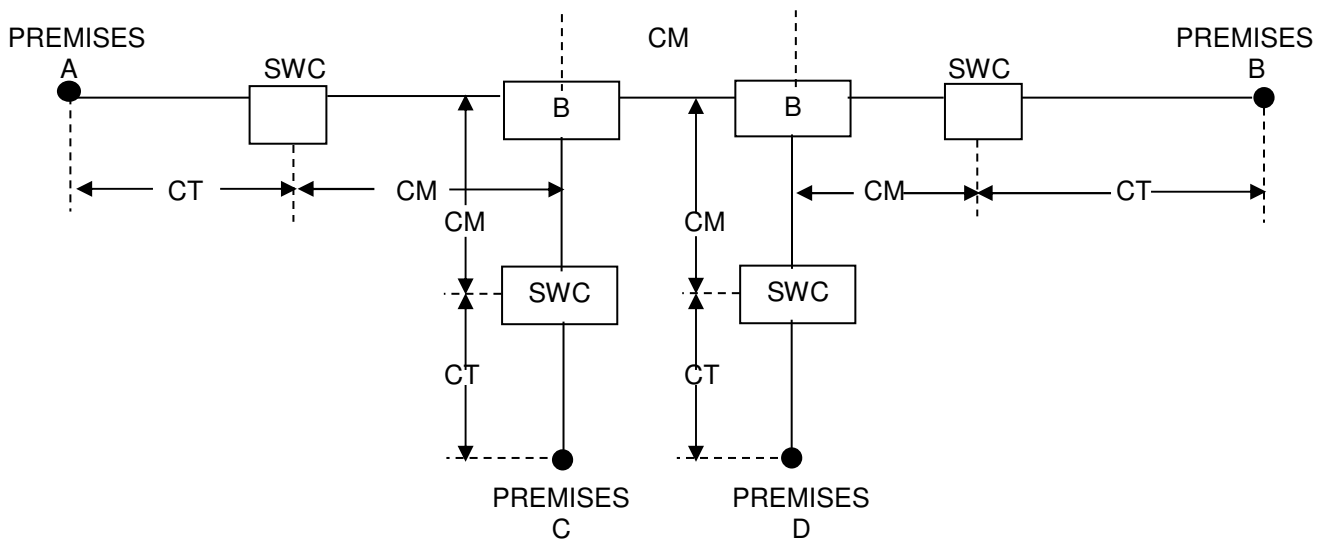

CT - CHANNEL TERMINATION
CM - CHANNEL MILEAGE
B - BRIDGING
SWC - SERVING WIRE CENTER

Applicable rate elements are:

- Channel Terminations (4 applicable)
- Channel Mileage (5 sections, each from appropriate mileage band)
- Bridging Optional Feature (6 applicable, i.e., each bridge port)

(1) Effective June 30, 2021, this Service will no longer be available for purchase by new or existing customers. In addition, requests to move, add, change, or renew existing service arrangements will not be accepted. Following the expiration of a customer's existing term agreement, service will be provided on a month-to-month basis at the applicable Monthly rates until the service is discontinued. The Company currently plans to discontinue this service on or after June 30, 2024.

(AT)
|
(AT)

ACCESS SERVICES

7. SPECIAL ACCESS SERVICE-(Continued)

7.1 General-(Continued)

7.1.3 Service Configurations-(Continued)

C. WATS Access Line Service(1)

(CP)

WATS Access Line (WAL) provides a Voice Grade(1) Channel Termination and Channel Mileage, where appropriate, between the End User premises and the WATS serving office and is used in conjunction with Switched Access Service as set forth in Section 6, Paragraph 6.2.5 and 6.3.6, preceding.

(CP)

The following diagram depicts a WATS Access Line Service connecting a customer designated premises to the WATS serving office. The customer's serving wire center and the WATS serving office are located 10 miles apart.

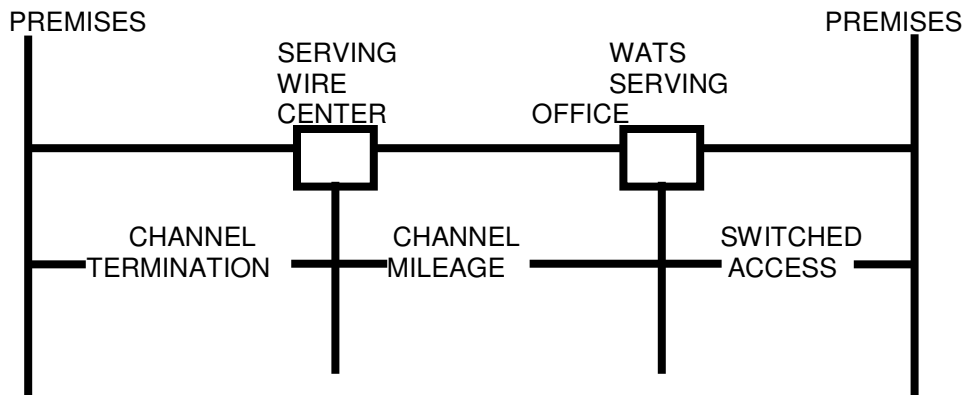

Applicable rate elements for the WATS Access Line are:

- Channel Termination (1 applicable)
- Channel Mileage (mileage band over 8 to 25 miles)
- Optional Features and Functions (when applicable)

In addition, a Special Access Surcharge, as set forth in 7.3.2, following, a Message Station Equipment Recovery Charge as set forth in 7.3.3, following, and/or an Inside Wire Recovery Charge as set forth in 7.3.9, following, may be applicable.

- (1) Effective June 30, 2021, this Service will no longer be available for purchase by new or existing customers. In addition, requests to move, add, change, or renew existing service arrangements will not be accepted. Following the expiration of a customer's existing term agreement, service will be provided on a month-to-month basis at the applicable Monthly rates until the service is discontinued. The Company currently plans to discontinue this service on or after June 30, 2024.

(AT)
|
(AT)

ACCESS SERVICES

7. SPECIAL ACCESS SERVICE-(Continued)

7.1 General-(Continued)

7.1.3 Service Configurations-(Continued)

D. Service to Service Through Connect Arrangement

The following diagram depicts Voice Grade(2) Services, extended from DS1 multiplexed services, utilizing a through connect arrangement in a Telephone Company Hub. (CP)
Additional channel mileage was required to co-terminate the services.

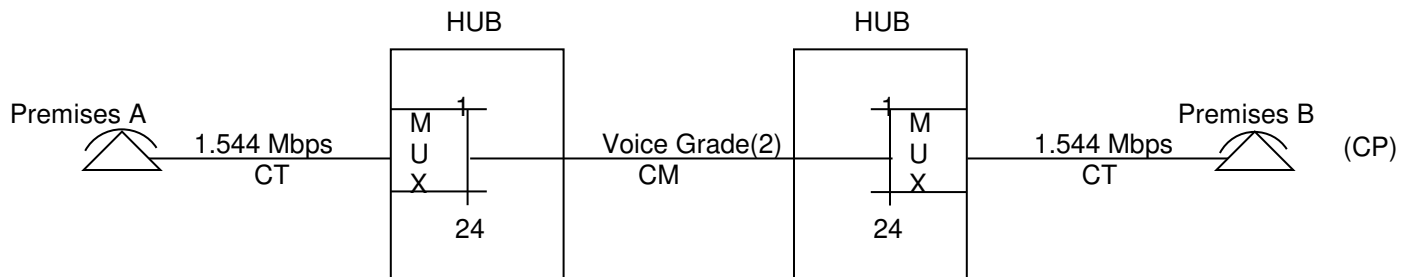

CT - Channel Termination
CM - Channel Mileage
0 - Service to Service Through Connect Arrangement

Applicable Rate Elements are:

- Two 1.544 Mbps Channel Terminations (1)
- Two DS1 to Voice Multiplexers (1)
- Voice Grade(2) Channel Mileage (CP)
- Multiplexer to Multiplexer Service to Service Through Connect Arrangement

- (1) Service already established
- (2) Effective June 30, 2021, this Service will no longer be available for purchase by new or existing customers. (AT)
In addition, requests to move, add, change, or renew existing service arrangements will not be accepted.
Following the expiration of a customer's existing term agreement, service will be provided on a month-to-month basis at the applicable Monthly rates until the service is discontinued. The Company currently plans to discontinue this service on or after June 30, 2024. (AT)

ACCESS SERVICES

7. SPECIAL ACCESS SERVICE-(Continued)

7.1 General-(Continued)

7.1.7 Accepting Testing-(Continued)

- A. For Voice Grade(1) analog services, (including WATS Access Lines)(1) acceptance tests will include tests for loss, three-tone slope, DC continuity, operational signaling, C-notched noise and C-message noise when these parameters are applicable and specified in the order for service. Additionally, for Voice Grade(1) Services, a balance (improved loss) test will be made if the customer has ordered the Improved Return Loss or Improved Equal Level Echo Path Loss optional features. (CP)
- B. For other analog services, acceptance tests will include tests for the parameters applicable to the service and specified in the order for service.
- C. For digital services, acceptance tests will include tests applicable to the service as specified in the technical references listed in Paragraph 7.2, following.

In addition to the above tests, Additional Cooperative Acceptance Testing for Voice Grade(1) Services and Digital to test other parameters, as described in Section 13, Paragraph 13.3.5, B., following, is available at the customer's request. All test results will be made available to the customer upon request. (CP)

7.1.8 Ordering Options and Conditions

Special Access Service is ordered under the Access Order Provisions set forth in Section 5, preceding. Also included in that section are other charges which may be associated with ordering Special Access Service (e.g., Service Date Change Charges, Cancellation Charges, etc.).

- (1) Effective June 30, 2021, this Service will no longer be available for purchase by new or existing customers. In addition, requests to move, add, change, or renew existing service arrangements will not be accepted. Following the expiration of a customer's existing term agreement, service will be provided on a month-to-month basis at the applicable Monthly rates until the service is discontinued. The Company currently plans to discontinue this service on or after June 30, 2024. (AT)

ACCESS SERVICES

7. SPECIAL ACCESS SERVICE-(Continued)

7.2 Service Descriptions

For the purposes of ordering, there are eight categories of Special Access Service. These are:

Metallic(1) (MT)	(CP)
Telegraph Grade(1) (TG)	
Voice Grade(1) (VG)	(CP)
MegaLink Data(1) (DA)	(CP)
High Capacity (HC)	

Each service consists of a basic channel to which a technical specifications package (customized or pre-defined), channel interface(s) and, when desired, optional features, BSEs and functions are added to construct the service desired by the customer. Each of the components of the service are described in this section.

Customized technical specifications packages will be provided where technically feasible. If the Telephone Company determines that the requested parameter specifications are not compatible, the customer will be advised and given the opportunity to change the order.

When a customized channel is ordered the customer will be notified whether Additional Engineering Charges apply. In such cases, the customer will be given an estimate of the hours to be billed before any further action is taken on the order.

The channel description specifies the characteristics of the basic channel and indicates whether the channel is provided between customer designated premises or between a customer designated premises and a Telephone Company Hub where bridging or multiplexing functions are performed.

- (1) Effective June 30, 2021, this Service will no longer be available for purchase by new or existing customers. In addition, requests to move, add, change, or renew existing service arrangements will not be accepted. Following the expiration of a customer's existing term agreement, service will be provided on a month-to-month basis at the applicable Monthly rates until the service is discontinued. The Company currently plans to discontinue this service on or after June 30, 2024.

(AT)
|
(AT)

P.S.C. Mo. - No. 36
ACCESS SERVICES TARIFF

Southwestern Bell Telephone
Company d/b/a AT&T Missouri

Section 7
10th Revised Sheet 14
Replacing 9th Revised Sheet 14

ACCESS SERVICES

7. SPECIAL ACCESS SERVICE-(Continued)

7.2 Service Descriptions-(Continued)

The Telephone Company will maintain existing transmission specifications on services installed prior to the effective date of this Tariff, except that the existing services with performance specifications exceeding the standard listed in this provision will be maintained at the performance levels specified in this Tariff. All services installed after the effective date of this Tariff will conform to the transmission specification standards contained in this Tariff or in the following Technical References for each category of service:

Metallic(1)	TR-NPL-000336	(CP)
Telegraph Grade(1)	TR-NPL-000336	
Voice Grade(1)	TR-TSY-000335	(CP)
		(RT)
		(RT)
MegaLink Data(1)	TR-NPL-000341	(CP)
	PUB 62310	
High Capacity	PUB 76625	
	PUB 62411	
	TR-INS-000342	

- (1) Effective June 30, 2021, this Service will no longer be available for purchase by new or existing customers. In addition, requests to move, add, change, or renew existing service arrangements will not be accepted. Following the expiration of a customer's existing term agreement, service will be provided on a month-to-month basis at the applicable Monthly rates until the service is discontinued. The Company currently plans to discontinue this service on or after June 30, 2024. (AT)
- |
- (AT)

P.S.C. Mo. - No. 36
ACCESS SERVICES TARIFF

Southwestern Bell Telephone
Company d/b/a AT&T Missouri

Section 7
3rd Revised Sheet 15
Replacing 2nd Revised Sheet 15

(CP)ACCESS SERVICES

7. SPECIAL ACCESS SERVICE-(Continued)

7.2 Service Descriptions-(Continued)

7.2.1 Metallic Service(1)

(CP)

A. Basic Channel Description

A metallic channel is an unconditioned two-wire channel capable of transmitting low speed varying signals at rates up to 30 baud. This channel is provided by metallic or equivalent facilities. Metallic channels are provided between customer designated premises or between a customer designated premises and a Telephone Company Hub where bridging functions are performed. Interoffice metallic facilities will be limited in length to a total of five miles per channel.

B. Technical Specifications Packages

<u>Parameter</u>	<u>Package MT-</u>			
	<u>C</u>	<u>1</u>	<u>2</u>	<u>3</u>
DC Resistance Between Conductors	X	X	X	
Loop Resistance	X			X
Shunt Capacitance	X			X

The technical specifications are delineated in Technical Reference
PUB 62502.

- (1) Effective June 30, 2021, this Service will no longer be available for purchase by new or existing customers. In addition, requests to move, add, change, or renew existing service arrangements will not be accepted. Following the expiration of a customer's existing term agreement, service will be provided on a month-to-month basis at the applicable Monthly rates until the service is discontinued. The Company currently plans to discontinue this service on or after June 30, 2024.

(AT)

(AT)

ACCESS SERVICES

7. SPECIAL ACCESS SERVICE-(Continued)

7.2 Service Descriptions-(Continued)

7.2.1 Metallic Service(1)-(Continued)

(CP)

C. Channel Interfaces

Compatible channel interfaces are set forth in Technical References at the end of Paragraph 7.2.

D. Optional Features, BSEs and Functions

1. Central Office Bridging BSE Capability

- a. Three Premises Bridging - Provision of tip-to-tip and ring-to-ring connection in a central office of a metallic pair to a third customer designated premises.
- b. Series Bridging of up to 26 customer designated premises.

The following table shows the technical specifications packages with which the optional features, BSEs and functions are available.

	<u>Available with Technical Specifications Package MT-</u>			
	<u>C</u>	<u>1</u>	<u>2</u>	<u>3</u>
Three Premises Bridging	X	X		X
Series Bridging	X		X	

- (1) Effective June 30, 2021, this Service will no longer be available for purchase by new or existing customers. In addition, requests to move, add, change, or renew existing service arrangements will not be accepted. Following the expiration of a customer's existing term agreement, service will be provided on a month-to-month basis at the applicable Monthly rates until the service is discontinued. The Company currently plans to discontinue this service on or after June 30, 2024.

(AT)
|
(AT)

ACCESS SERVICES

7. SPECIAL ACCESS SERVICE-(Continued)

7.2 Service Descriptions-(Continued)

7.2.2 Telegraph Grade(1) Service

(CP)

A. Basic Channel Description

A telegraph grade channel is an unconditioned channel capable of transmitting binary signals at rates of 0-75 baud or 0-150 baud. This channel is furnished for half-duplex or duplex operation.

Telegraph grade channels are provided between customer designated premises or between a customer designated premises and a Telephone Company Hub.

B. Technical Specifications Packages

Package TG-

<u>Parameter</u>	<u>C</u>	<u>1</u>	<u>2</u>
Telegraph Distortion	X	X	X

The technical specifications are delineated in Technical Reference PUB 62502.

C. Channel Interfaces

Compatible channel interfaces are set forth in Technical References at the end of Paragraph 7.2.

D. Optional Features, BSEs and Functions

1. Telegraph Bridging BSE (two-wire and four-wire)

The following table shows the technical specifications packages with which the optional features, BSEs and functions are available.

Available with Technical Specifications Package TG-

Telegraph Bridging	<u>C</u>	<u>1</u>	<u>2</u>
	X	X	X

- (1) Effective June 30, 2021, this Service will no longer be available for purchase by new or existing customers. In addition, requests to move, add, change, or renew existing service arrangements will not be accepted. Following the expiration of a customer's existing term agreement, service will be provided on a month-to-month basis at the applicable Monthly rates until the service is discontinued. The Company currently plans to discontinue this service on or after June 30, 2024.

(AT)
|
(AT)

**P.S.C. Mo. - No. 36
ACCESS SERVICES TARIFF**

Southwestern Bell Telephone
Company d/b/a AT&T Missouri

Section 7
3rd Revised Sheet 18
Replacing 2nd Revised Sheet 18

ACCESS SERVICES

7. SPECIAL ACCESS SERVICE-(Continued)

7.2 Service Descriptions-(Continued)

7.2.3 Voice Grade(2) Service

(CP)

A. Basic Channel Description

A voice grade channel is a channel which provides voice frequency transmission capability in the nominal frequency range of 300 to 3000 Hz and may be terminated two-wire or four-wire. Voice grade channels are provided between customer designated premises, between a customer designated premises and a Telephone Company Hub, or between a customer designated premises and the WATS serving office.

B. Technical Specifications Packages

Parameter	Package VG-													W*	
	C(1)	1	2	3	4	5	6	7	8	9	10	11	12		
Attenuation															
Distortion	X	X	X	X	X	X	X	X	X	X	X	X	X	X	X
C-Message Noise	X	X	X	X	X	X	X	X	X	X	X	X	X	X	X
Echo Control	X	X	X	X		X		X	X				X	X	X+
Envelope Delay															
Distortion	X						X	X	X	X	X	X	X	X	X
Frequency Shift	X						X	X	X	X	X	X	X	X	X
Impulse Noise	X					X	X	X	X	X	X	X	X	X	X
Intermodulation															
Distortion	X						X	X	X	X	X	X	X	X	X
Loss Deviation	X	X	X	X	X	X	X	X	X	X	X	X	X	X	X
Phase Hits, Gain															
Hits, and															
Dropouts	X														
Phase Jitter	X						X	X	X	X	X	X	X	X	
Signal-to-C															
Message Noise					X										
Signal-to-C															
Notch Noise	X					X	X	X	X	X	X	X	X	X	X

* Denotes WATS Access Lines (WALs)(2)

(CP)

+ When WAL(2) extensions are provided, Echo Control limits are not applicable.

(CP)

(1) The desired parameters are selected by the customer from the list of available parameters.

(2) Effective June 30, 2021, this Service will no longer be available for purchase by new or existing customers. In addition, requests to move, add, change, or renew existing service arrangements will not be accepted. Following the expiration of a customer's existing term agreement, service will be provided on a month-to-month basis at the applicable Monthly rates until the service is discontinued. The Company currently plans to discontinue this service on or after June 30, 2024.

(AT)

(AT)

ACCESS SERVICES

7. SPECIAL ACCESS SERVICE-(Continued)

7.2 Service Descriptions-(Continued)

7.2.3 Voice Grade(2) Service-(Continued) (CP)

B. Technical Specifications Packages-(Continued)

The technical specifications for these parameters are delineated in Technical References set forth at the end of Paragraph 7.2.

C. Channel Interfaces

The following channel interfaces for Voice Grade Service do not require signaling capability: AH, DA, DB, DD, DE, DS, NO, PR and TF.

The following channel interfaces for Voice Grade Service require signaling capability: AB, AC, CT, DX, DY, EA, EB, EC, EX, GO, GS, LA, LB, LC, LO, LR, LS, RV and SF (1).

Combination of channel interfaces DS, GS, and LS for WALs(2) require signaling as defined in Section 6.2.5. (CP)

Compatible channel interfaces and available WAL(2) channel interfaces are set forth in Technical References at the end of Paragraph 7.2. (CP)

D. Analog Service to Service Through Connect Arrangement

Multiplexed Arrangement

This provides for the interconnection of two subtending analog channels derived from DS1 multiplexed services. The through connect will be provisioned in lieu of a typical voice grade channel termination. The ordering customer must provide channel assignments for both. Voice Grade channel mileage is required if the multiplexed services are terminated in two separate Hubs.

(1) This feature is obsolete, and limited to existing installations at existing locations for existing customers as of October 6, 1995.

(2) Effective June 30, 2021, this Service will no longer be available for purchase by new or existing customers. In addition, requests to move, add, change, or renew existing service arrangements will not be accepted. Following the expiration of a customer's existing term agreement, service will be provided on a month-to-month basis at the applicable Monthly rates until the service is discontinued. The Company currently plans to discontinue this service on or after June 30, 2024. (AT)

ACCESS SERVICES

7. SPECIAL ACCESS SERVICE-(Continued)

7.2 Service Descriptions-(Continued)

7.2.3 Voice Grade(1) Service-(Continued) (CP)

E. Optional Features, BSEs and Functions

1. Central Office Bridging BSE Capability

a. Voice Bridging (two-wire and four-wire)

b. Data Bridging (two-wire and four-wire)

(RT)
(RT)

c. Telemetry and Alarm Bridging

(CT)

Split Band, Active Bridging
Passive Bridging
Summation, Active Bridging

2. Central Office Multiplexing BSE

Voice to Telegraph Grade(1) (43-Type Carrier): An arrangement that converts a voice grade channel to telegraph grade(1) channels using frequency division multiplexing. (CP)
(CP)

3. Conditioning BSE

Conditioning provides more specific transmission characteristics for Voice Grade Services. C-type conditioning controls attenuation distortion and envelope delay distortion. Sealing current helps maintain continuity on dry metallic(1) loops. (CP)

For two-point services, the parameters apply to each service. For multipoint services, the parameters apply to each mid-link or end link. C-type conditioning and data capability may be combined on the same service.

(1) Effective June 30, 2021, this Service will no longer be available for purchase by new or existing customers. In addition, requests to move, add, change, or renew existing service arrangements will not be accepted. Following the expiration of a customer's existing term agreement, service will be provided on a month-to-month basis at the applicable Monthly rates until the service is discontinued. The Company currently plans to discontinue this service on or after June 30, 2024. (AT)
|
(AT)

ACCESS SERVICES

7. SPECIAL ACCESS SERVICE-(Continued)

7.2 Service Descriptions-(Continued)

7.2.3 Voice Grade(2) Service-(Continued)

(CP)

E. Optional Features, BSEs and Functions-(Continued)

3. Conditioning BSE-(Continued)

a. C-Type Conditioning (1)

C-type conditioning is provided for the additional control of attenuation distortion and envelope delay distortion on data services. The attenuation distortion and envelope delay distortion specifications for C-type conditioning are:

Attenuation Distortion
(Frequency Response)
Relative to 1004 Hz

Frequency Range (Hz)	Variation (dB)
400-2800	-1.0 to +2.0
300-3000	-1.0 to +3.0
3000-3200	-2.0 to +6.0

Envelope Delay
Distortion

<u>Frequency Range (Hz)</u>	<u>Variation (micro- seconds)</u>
1000-2600	100
800-2600	200
600-2600	300
500-2800	600
500-3000	3000

- (1) This feature is obsolete, and limited to existing installations at existing locations, for existing customers.
 (2) Effective June 30, 2021, this Service will no longer be available for purchase by new or existing customers. In addition, requests to move, add, change, or renew existing service arrangements will not be accepted. Following the expiration of a customer's existing term agreement, service will be provided on a month-to-month basis at the applicable Monthly rates until the service is discontinued. The Company currently plans to discontinue this service on or after June 30, 2024.

(AT)
|
(AT)

ACCESS SERVICES

7. SPECIAL ACCESS SERVICE-(Continued)

7.2 Service Descriptions-(Continued)

7.2.3 Voice Grade(1) Service-(Continued)

(CP)

E. Optional Features, BSEs and Functions-(Continued)

3. Conditioning BSE-(Continued)

b. Sealing Current Conditioning

Sealing current conditioning is provided to help maintain continuity on dry metallic(1) loops. It is usually associated with four-wire DA or NO-type channel interfaces.

(CP)

c. Improved Attenuation Distortion (IAD)

Improved Attenuation Distortion upgrades the frequency versus loss response limits of the channel. The specifications for Improved Attenuation Distortion are delineated in Technical Reference set forth at the end of Paragraph 7.2.

d. C-Conditioning

C-Conditioning upgrades the frequency response and envelope delay distortion limits of the analog data channel. The specifications for C-Conditioning, which are less stringent than C-Type conditioning, are delineated in Technical References set forth at the end of Paragraph 7.2.

e. Improved Envelope Delay Distortion

Improved Envelope Delay Distortion Upgrades the frequency vs. delay response limits of the analog data channel. The specifications for Improved Envelope Delay Distortion are delineated in Technical References set forth at the end of Paragraph 7.2.

- (1) Effective June 30, 2021, this Service will no longer be available for purchase by new or existing customers. In addition, requests to move, add, change, or renew existing service arrangements will not be accepted. Following the expiration of a customer's existing term agreement, service will be provided on a month-to-month basis at the applicable Monthly rates until the service is discontinued. The Company currently plans to discontinue this service on or after June 30, 2024.

(AT)

(AT)

P.S.C. Mo. - No. 36
ACCESS SERVICES TARIFF

Southwestern Bell Telephone
Company d/b/a AT&T Missouri

Section 7
5th Revised Sheet 23
Replacing 4th Revised Sheet 23

ACCESS SERVICES

7. SPECIAL ACCESS SERVICE-(Continued)

7.2 Service Descriptions-(Continued)

7.2.3 Voice Grade Service(1)-(Continued)

(CP)

E. Optional Features, BSEs and Functions-(Continued)

4. Reserved for future use.

(1) Effective June 30, 2021, this Service will no longer be available for purchase by new or existing customers. In addition, requests to move, add, change, or renew existing service arrangements will not be accepted. Following the expiration of a customer's existing term agreement, service will be provided on a month-to-month basis at the applicable Monthly rates until the service is discontinued. The Company currently plans to discontinue this service on or after June 30, 2024.

(AT)

(AT)

ACCESS SERVICES

7. SPECIAL ACCESS SERVICE-(Continued)

7.2 Service Descriptions-(Continued)

7.2.3 Voice Grade(1) Service-(Continued)

(CP)

E. Optional Features, BSEs and Functions-(Continued)

5. Improved Termination

Improved termination at a four-wire point of termination, ordered with either an effective two-wire or effective four-wire channel: Provides for a fixed 600 ohm impedance, variable level range and simplex reversal. Telephone Company equipment is required at the customer's premises where this option is ordered. The improved termination parameters are delineated in Technical References set forth at the end of Paragraph 7.2.

6. Improved Return Loss

Improved return loss at a two-wire point of termination ordered only on effective two-wire channels: Provides for more stringent echo control specifications. In order for this option to be applicable, the transmission path must be four-wire at one POT and two-wire at the other POT. Placement of Telephone Company equipment may be required at the customer's premises with the two-wire POT. The improved return loss parameters are delineated in Technical References set forth at the end of Paragraph 7.2.

7. Data Capability

Data capability provides transmission characteristics suitable for data communications. Specifically, data capability provides for the control of signal to C-notched noise ratio and intermodulation distortion.

The signal to C-notched noise ratio and intermodulation distortion parameters for data capability are:

- Signal to C-notched noise ratio is equal to or greater than 32 dB

- (1) Effective June 30, 2021, this Service will no longer be available for purchase by new or existing customers. In addition, requests to move, add, change, or renew existing service arrangements will not be accepted. Following the expiration of a customer's existing term agreement, service will be provided on a month-to-month basis at the applicable Monthly rates until the service is discontinued. The Company currently plans to discontinue this service on or after June 30, 2024.

(AT)

(AT)

ACCESS SERVICES

7. SPECIAL ACCESS SERVICE-(Continued)

7.2 Service Descriptions-(Continued)

7.2.3 Voice Grade(1) Service-(Continued)

(CP)

E. Optional Features, BSEs and Functions-(Continued)

7. Data Capability-(Continued)

- Intermodulation distortion:
- Signal to second order modulation products (R2) is equal to or greater than 38 dB
- Signal to third order modulation products (R3) is equal to or greater than 42 dB

When a service equipped with data capability is used for voice communications, the quality of the voice transmission may not be satisfactory.

8. Improved Echo Control

Improved Echo Control for two-wire WALs(1) provides more stringent control of reflected signals. Placement of Telephone Company equipment may be required at the customer's premises. The Improved Echo Control specifications are delineated in Technical References set forth at the end of Paragraph 7.2.

(CP)

9. Improved Equal Level Echo Path Loss

Provides improved echo control at four-wire interface for effective two-wire voice grade configurations. Specifications can only be met with limited facility configurations. Improved Equal Level Echo Path Loss specifications are delineated in Technical References set forth at the end of Paragraph 7.2.

- (1) Effective June 30, 2021, this Service will no longer be available for purchase by new or existing customers. In addition, requests to move, add, change, or renew existing service arrangements will not be accepted. Following the expiration of a customer's existing term agreement, service will be provided on a month-to-month basis at the applicable Monthly rates until the service is discontinued. The Company currently plans to discontinue this service on or after June 30, 2024.

(AT)

(AT)

ACCESS SERVICES

7. SPECIAL ACCESS SERVICE-(Continued)

7.2 Service Descriptions-(Continued)

7.2.3 Voice Grade(1) Service-(Continued)

(CP)

E. Optional Features, BSEs and Functions-(Continued)

10. Signaling Capability

Signaling capability provides for the process by which one customer premises alerts another customer premises on the same service with which it wishes to communicate.

11. Selective Signaling Arrangement

An arrangement that permits code selective ringing for up to ten codes on a multipoint service.

12. Transfer Arrangement

An arrangement that affords the customer an additional measure of flexibility in the use of their access channel(s). The arrangement can be utilized to transfer a leg of a Special Access Service to another channel that terminates in either the same or a different customer premises. A key activated or dial-up control service is required to operate the transfer arrangement. A spare line, if required, is not included as part of the option.

The following table shows the technical specifications packages with which the optional features, BSEs and functions are available.

	Available with Technical Specifications Package VG-													
	<u>C</u>	<u>1</u>	<u>2</u>	<u>3</u>	<u>4</u>	<u>5</u>	<u>6</u>	<u>7</u>	<u>8</u>	<u>9</u>	<u>10</u>	<u>11</u>	<u>12</u>	<u>W</u>
C-Type Conditioning (1)	X					X	X	X	X	X	X			
Central Office Bridging Capability	X		X			X	X					X	X	X
Central Office Multiplexing	X						X							
C-Conditioning	X					X	X	X	X	X	X			

(1) This feature is obsolete, and limited to existing installations at existing locations, for existing customers.

(2) Effective June 30, 2021, this Service will no longer be available for purchase by new or existing customers. In addition, requests to move, add, change, or renew existing service arrangements will not be accepted. Following the expiration of a customer's existing term agreement, service will be provided on a month-to-month basis at the applicable Monthly rates until the service is discontinued. The Company currently plans to discontinue this service on or after June 30, 2024.

(AT)
|
(AT)

**P.S.C. Mo. - No. 36
ACCESS SERVICES TARIFF**

Southwestern Bell Telephone
Company d/b/a AT&T Missouri

Section 7
6th Revised Sheet 27
Replacing 5th Revised Sheet 27

ACCESS SERVICES

7. SPECIAL ACCESS SERVICE-(Continued)

7.2 Service Descriptions-(Continued)

7.2.3 Voice Grade(1) Service-(Continued) (CP)

E. Optional Features, BSEs and Functions-(Continued)

Available with Technical
Specifications Package VG-

	<u>C</u>	<u>1</u>	<u>2</u>	<u>3</u>	<u>4</u>	<u>5</u>	<u>6</u>	<u>7</u>	<u>8</u>	<u>9</u>	<u>10</u>	<u>11</u>	<u>12</u>	<u>W</u>	
Data Capability	X						X				X				
Improved Attenuation Distortion (IAD)	X					X	X	X	X	X	X			X	
Improved Echo Control at two-wire WAL(1) point of termination														X+	(CP)
Improved Termination at four-wire point of termina- tion	X	X	X	X	X	X	X	X	X	X	X	X	X		
Improved Return Loss at two-wire point of termina- tion	X	X	X				X								
Improved ELEPL Sealing Current	X	X	X	X	X		X								
Conditioning	X	X				X	X				X		X		
Selective Signal- ing Arrangement	X	X													
Signaling Capability	X	X	X	X				X	X	X				*	
Improved Envelope Delay															
Distortion(IEDD) Transfer	X						X	X	X	X	X	X			
Arrangement	X	X	X	X	X	X	X	X	X	X	X	X	X	X	

* Signaling is provided in conjunction with Switched Access Service.

+ When WAL(1) extensions are provided, Echo Control limits are not applicable. (CP)

(1) Effective June 30, 2021, this Service will no longer be available for purchase by new or existing customers. In addition, requests to move, add, change, or renew existing service arrangements will not be accepted. Following the expiration of a customer's existing term agreement, service will be provided on a month-to-month basis at the applicable Monthly rates until the service is discontinued. The Company currently plans to discontinue this service on or after June 30, 2024. (AT)

P.S.C. Mo. - No. 36
ACCESS SERVICES TARIFF

Southwestern Bell Telephone
Company d/b/a AT&T Missouri

Section 7
4th Revised Sheet 28
Replacing 3rd Revised Sheet 28

ACCESS SERVICES

7. SPECIAL ACCESS SERVICE-(Continued)

7.2 Service Descriptions-(Continued)

7.2.3 Voice Grade(1) Service-(Continued)

(CP)

F. Four-Wire/Two-Wire Conversion

When a customer requests that an effective four-wire channel be terminated with a two-wire channel interface at the customer-designated premises, a four-wire to two-wire conversion is required. The rate for the conversion is included as part of the basic Channel Termination rate.

- (1) Effective June 30, 2021, this Service will no longer be available for purchase by new or existing customers. In addition, requests to move, add, change, or renew existing service arrangements will not be accepted. Following the expiration of a customer's existing term agreement, service will be provided on a month-to-month basis at the applicable Monthly rates until the service is discontinued. The Company currently plans to discontinue this service on or after June 30, 2024.

(AT)

(AT)

ACCESS SERVICES

7. SPECIAL ACCESS SERVICE-(Continued)

7.2 Service Descriptions-(Continued)

7.2.7 MegaLink Data(1) Service

(CP)

A. Basic Channel Description

A MegaLink Data channel is a channel for duplex four-wire transmission of synchronous serial data at the rate of 4.8, 9.6, 19.2, 56.0 kbps or 64 kbps Clear Channel (CC)*. The actual bit rate is a function of the channel interface selected by the customer. The channel provides a synchronous service with timing provided by the Telephone Company through the Telephone Company's facilities to the customer in the received bit stream. MegaLink Data channels are provided between customer-designated premises for two-point service at all speeds or between a customer - designated premises and a Telephone Company digital hub for multipoint or multiplexed service at all speeds except 64 kbps (CC).

(RT)

It is the responsibility of the customer to provide the Channel Service Unit-type equipment or other Network Channel Terminating Equipment associated with the MegaLink Data Channel at the customer premises.

B. Technical Specifications Packages

Package DA-

Parameter	<u>1</u>	<u>2</u>	<u>3</u>	<u>4</u>	<u>5</u>	<u>6</u>
Error-Free Seconds	X	X	X	X	X	X

The Telephone Company will provide a channel capable of meeting a monthly average performance equal to or greater than 99.875 percent error-free seconds (if provided through a Digital Data Hub) while the channel is in service, if it is measured through a CSU equivalent which is designed, manufactured and maintained to conform with the specifications contained in the appropriate technical reference listed in Paragraph 7.2, preceding.

Voltages which are compatible with MegaLink Data Service are delineated in the appropriate technical reference listed in Paragraph 7.2, preceding.

*64 kbps Clear Channel (CC) is offered only where equipment and facilities are available.

(1) Effective June 30, 2021, this Service will no longer be available for purchase by new or existing customers. In addition, requests to move, add, change, or renew existing service arrangements will not be accepted. Following the expiration of a customer's existing term agreement, service will be provided on a month-to-month basis at the applicable Monthly rates until the service is discontinued. The Company currently plans to discontinue this service on or after June 30, 2024.

(AT)

(AT)

**P.S.C. Mo. - No. 36
ACCESS SERVICES TARIFF**

Southwestern Bell Telephone
Company d/b/a AT&T Missouri

Section 7
7th Revised Sheet 36
Replacing 6th Revised Sheet 36

ACCESS SERVICES

7. SPECIAL ACCESS SERVICE-(Continued)

7.2 Service Descriptions-(Continued)

7.2.7 MegaLink Data(1) Service-(Continued) (CP)

C. Channel Interfaces

The following channel interfaces (CI's) define the bit rates that are available for a Digital Data channel:

<u>CI</u>	<u>Bit Rate</u>	(RT)
DU-48	4.8 kbps	
DU-96	9.6 kbps	
DU-19	19.2 kbps	
DU-56	56.0 kbps	
DU-64	64.0 kbps (CC)*	

Compatible channel interfaces are set forth in Technical References at the end of Paragraph 7.2.

D. Service to Service Through Connect Arrangement

This provides the interconnection of two subtending digital data channels derived from DS1 multiplexed services. The through connect will be provisioned in lieu of a typical MegaLink Data channel termination. The through connect will be provisioned for all MegaLink Data speeds; 4.8, 9.6, 19.2, 56 kbps and 64 kbps (CC). The ordering customer must provide channel assignments for both. Channel mileage is required if the multiplexed services are terminated in two separate digital Hubs. (RT)

E. Optional Features, BSEs and Functions

I. Central Office Bridging BSE Capability

2. Transfer Arrangement

An arrangement that affords the customer an additional measure of protection and/or flexibility in the use of their access channel(s) on a 1xN basis. The arrangement can be utilized to transfer a leg of a Special Access Service to either a spare or working channel that terminates in either the same or a different customer premises. This arrangement is only available at a Telephone Company-designated Hub. A Key Activated or Dial-Up Control Service is required to operate the transfer arrangement. A spare line, if required, is not included as a part of the option.

*MegaLink Data Service 64 kbps channel interface is offered only with Clear Channel.

(1) Effective June 30, 2021, this Service will no longer be available for purchase by new or existing customers. In addition, requests to move, add, change, or renew existing service arrangements will not be accepted. Following the expiration of a customer's existing term agreement, service will be provided on a month-to-month basis at the applicable Monthly rates until the service is discontinued. The Company currently plans to discontinue this service on or after June 30, 2024. (AT)

**P.S.C. Mo. - No. 36
ACCESS SERVICES TARIFF**

Southwestern Bell Telephone
Company d/b/a AT&T Missouri

Section 7
5th Revised Sheet 36.1
Replacing 4th Revised Sheet 36.1

ACCESS SERVICES

7. SPECIAL ACCESS SERVICE-(Continued)

7.2 Service Descriptions-(Continued)

7.2.7 MegaLink Data(1) Service-(Continued) (CP)

E. Optional Features, BSEs and Functions (Continued)

3. Secondary Channel Capability BSE

Secondary Channel capability provides for an additional low-speed digital transmission channel within the existing 4.8, 9.6, 19.2 and 56.0 kbps primary channels. It is available as a point-to-point or a multipoint service utilizing a nonrepeated channel termination. The Secondary Channel can be used as a communications channel for the controlling and monitoring of a customer's network. (RT)

The following table shows the technical specifications packages with which the optional features, BSEs and functions are available.

	<u>Available with Technical Specifications Package DA-</u>					
	<u>1</u>	<u>2</u>	<u>3</u>	<u>4</u>	<u>5</u>	<u>6</u>
Central Office Bridging Capability	X	X	X	X	X	
Transfer Arrangement	X	X	X	X	X	X
Secondary Channel Capability	X	X	X	X	X	

(1) Effective June 30, 2021, this Service will no longer be available for purchase by new or existing customers. In addition, requests to move, add, change, or renew existing service arrangements will not be accepted. Following the expiration of a customer's existing term agreement, service will be provided on a month-to-month basis at the applicable Monthly rates until the service is discontinued. The Company currently plans to discontinue this service on or after June 30, 2024. (AT)

|
(AT)

ACCESS SERVICES

7. SPECIAL ACCESS SERVICE

7.2 Service Descriptions (cont'd)

7.2.8 High Capacity Service

A. Basic Channel Description

A High Capacity channel is a channel for the transmission of nominal 64.0 Kbps(1)(2) or 1.544 or 44.736 Mbps isochronous serial data. The actual bit rate and framing format is a function of the channel interface selected by the customer. High Capacity channels are provided (a) between customer designated premises, (b) between a customer designated premises and a Telephone Company Hub, (c) Hub to Hub for Network Reconfiguration Service at 1.544 Mbps transmission or (d) between a Network Reconfiguration Service Hub and a Telephone Company Hub at 1.544 Mbps transmission. (CP)

It is the responsibility of the customer to provide the Network Channel Terminating Equipment associated with the High Capacity channel at the customer's premises. The interim program, for interconnection of such equipment is set forth in Technical Reference PUB AS No. 1.

B. Technical Specifications Packages

Parameters	Package HC-		
	<u>0</u>	<u>1</u>	<u>3</u>
Error-Free Seconds		X	

A channel with technical specifications package HC1 will be capable of an error-free second performance of 98.75 percent over a continuous 24-hour period as measured at the 1.544 Mbps rate through a CSU equivalent which is designed, manufactured and maintained to conform with the specifications contained in Technical References set forth at the end of Paragraph 7.2.

- (1) Available only as a channel of a 1.544 Mbps facility between two Telephone Company designated Hubs. The customer must provide system and channel assignment data.
- (2) Effective June 30, 2021, this Service will no longer be available for purchase by new or existing customers. In addition, requests to move, add, change, or renew existing service arrangements will not be accepted. Following the expiration of a customer's existing term agreement, service will be provided on a month-to-month basis at the applicable Monthly rates until the service is discontinued. The Company currently plans to discontinue this service on or after June 30, 2024.

(AT)
|
(AT)

**P.S.C. Mo. - No. 36
ACCESS SERVICES TARIFF**

Southwestern Bell Telephone
Company d/b/a AT&T Missouri

Section 7
7th Revised Sheet 38
Replacing 6th Revised Sheet 38

ACCESS SERVICES

7. SPECIAL ACCESS SERVICE-(Continued)

7.2 Service Descriptions-(Continued)

7.2.8 High Capacity Service-(Continued)

C. Channel Interfaces

The following channel interfaces (CI's) define the bit rates that are available for a High Capacity channel:

<u>CI</u>	<u>Bit Rate</u>
DS-15(1)(2)	1.544 Mbps (DS1)
DS-44	44.736 Mbps (DS3)

Compatible channel interfaces are set forth in Technical References at the end of Paragraph 7.2.

D. Service to Service Through Connect Arrangement

1. High Capacity Service Arrangement

This provides the interconnection of two DS1 at a Digital Hub.

2. Multiplexed Service Arrangement

This provides the interconnection of two digital channels extended from High Capacity multiplexed services. The through connect will be provisioned in lieu of a typical High Capacity channel termination. The ordering customer must provide channel assignments for both multiplexed services. Channel mileage is required if the multiplexed services are terminated in two separate digital hubs.

- (1) A 64.0 Kbps channel is available as a channel(s) of a 1.544 Mbps facility to a Telephone Company Hub.
- (2) Effective June 30, 2021, 64.0 Kbps will no longer be available for purchase by new or existing customers. In addition, requests to move, add, change, or renew existing service arrangements will not be accepted. Following the expiration of a customer's existing term agreement, service will be provided on a month-to-month basis at the applicable Monthly rates until the service is discontinued. The Company currently plans to discontinue this service on or after June 30, 2024.
- (AT)
|
(AT)

ACCESS SERVICES

7. SPECIAL ACCESS SERVICE-(Continued)

7.2 Service Descriptions-(Continued)

7.2.8 High Capacity Service-(Continued)

E. Optional Features, BSEs and Functions-(Continued)

3. Central Office Multiplexing BSE-(Continued)

b. DS1 to Voice

An arrangement that converts a 1.544 Mbps channel to 24 channels for use with Voice Grade Services. A channel of this DS1 to the Hub can also be used for a MegaLink Data, Metallic Service or WATS Access Lines.

c. DS1 to DSO

An arrangement that converts a 1.544 Mbps channel to 23 64.0 kbps channels utilizing digital time division multiplexing.

d. DSO to Subrate(1)

(CP)

An arrangement that converts a 64.0 kbps channel to subspeeds of up to twenty 2.4 kbps, ten 4.8 kbps or .6 kbps channels using digital time division multiplexing.

4. Clear Channel Capability BSE

Clear Channel Capability is an optional feature that provides the customer with an increase in useable bandwidth from 1.344 Mbps to 1.536 Mbps of an unconstrained data stream across the network. Clear Channel Capability is provided only on 1.544 Mbps High Capacity service and requires the customer signal at the channel interface to conform to Bipolar with Eight Zero Substitution (B8ZS) line code format as set forth in the technical reference for high capacity at the end of Paragraph 7.2. Customer equipment must be compatible with this method of providing the unconstrained signal.

- (1) Effective June 30, 2021, this Service will no longer be available for purchase by new or existing customers. In addition, requests to move, add, change, or renew existing service arrangements will not be accepted. Following the expiration of a customer's existing term agreement, service will be provided on a month-to-month basis at the applicable Monthly rates until the service is discontinued. The Company currently plans to discontinue this service on or after June 30, 2024.

(AT)

(AT)

ACCESS SERVICES

7. SPECIAL ACCESS SERVICE-(Continued)

7.2 Service Descriptions-(Continued)

7.2.8 High Capacity Service-(Continued)

E. Optional Features, BSEs and Functions-(Continued)

The following table shows the technical specifications packages with which the optional features, BSEs and functions are available.

	Available with Technical Specifications Package HC-			
	0	1	3	
Transfer Central Office Multiplexing:		X		
DS3 to DS1			X	
DSI to Voice		X		
DSI to DSO		X		
DSO to Subrate(1)(3)		X		(CP)
Transfer Arrange- ment		X		
Clear Channel Capability		X		
Extended Superframe Format		X		
Power Over the Interface(2)		X		

- (1) Available only on a channel of a 1.544 Mbps facility to a Telephone Company Hub or on a DS0 channel that connects to a customer's Network Reconfiguration Service (NRS) Network that contains a DS1 channel.
- (2) Obsolete, and limited to existing installations at existing locations, for existing customers.
- (3) Effective June 30, 2021, this Service will no longer be available for purchase by new or existing customers. (AT)
In addition, requests to move, add, change, or renew existing service arrangements will not be accepted. Following the expiration of a customer's existing term agreement, service will be provided on a month-to-month basis at the applicable Monthly rates until the service is discontinued. The Company currently plans to discontinue this service on or after June 30, 2024. (AT)

ACCESS SERVICES

7. SPECIAL ACCESS SERVICE-(Continued)

7.3 Rate Regulations-(Continued)

7.3.1 Types of Rates and Charges-(Continued)

B. Nonrecurring Charges-(Continued)

2. Installation of Optional Features, BSEs and Functions

Nonrecurring charges apply for the installation of some of the optional features, BSEs and functions available with Special Access Service. The charge applies whether the feature, BSE or function is installed coincident with the initial installation of service or at any time subsequent to the installation of service.

The optional features and BSEs for which nonrecurring charges apply are:

- Voice Grade(1) Data Capability (CP)
- Voice Grade(1) Improved Attenuation Distortion |
- Voice Grade(1) Improved Echo Control (CP)
- High Capacity Clear Channel Capability

- MegaLink Data(1) Loop Transfer Arrangement (CP)
- MegaLink Data(1) Secondary Channel (CP)

- High Capacity Transfer Arrangement

3. Service Rearrangements

Service Rearrangements are changes to existing (installed) services which do not result in either a change in the minimum period requirements as set forth in Section 5, Paragraph 5.2.6 and 5.2.7, preceding, or a change in the physical location of the point of termination at a customer-designated premises. Changes which result in the establishment of new minimum period obligations are treated as disconnects and starts.

Changes in the physical location of the point of termination are treated as moves and are described and charged for as set forth in Paragraph 7.3.5, following.

The charge to the customer for the service rearrangement is dependent on whether the change is administrative only in nature or involves actual physical change to the service.

Certain administrative changes will be made without charge(s) to the customer. These administrative changes are as follows:

- (1) Effective June 30, 2021, this Service will no longer be available for purchase by new or existing customers. In addition, requests to move, add, change, or renew existing service arrangements will not be accepted. Following the expiration of a customer's existing term agreement, service will be provided on a month-to-month basis at the applicable Monthly rates until the service is discontinued. The Company currently plans to discontinue this service on or after June 30, 2024. (AT)

ACCESS SERVICES

7. SPECIAL ACCESS SERVICE-(Continued)

7.3 Rate Regulations-(Continued)

7.3.1 Types of Rates and Charges-(Continued)

B. Nonrecurring Charges-(Continued)

3. Service Rearrangements-(Continued)

- Change of customer name, (i.e., the customer of record does not change, but rather the customer of record changes its name (e.g., AT&T-Long Lines to AT&T Communications),
- Change of customer or customer's end user premises address when the change of address is not a result of a physical relocation of the service,
- Change in billing date (name, address or contact name or telephone number),
- Change of agency authorization,

- Change of customer test line number,
- Change of customer or customer's end user contact name or telephone number, and
- Change of jurisdiction.

Administrative changes for which nonrecurring charges will apply are set forth as follows:

A change in the customer record (i.e., existing access service is provided and billed to a different entity) is considered an administrative service rearrangement when the new customer assumes liability for all current and prior charges for the service(s) and has complied with the regulations and conditions as set forth in Section 2, Paragraph 2.2.1, preceding, for the assignment and transfer of facilities, and no physical relocation or rearrangement of the service is required.

A nonrecurring charge will apply per circuit on a first and additional basis for the following change or combination of changes requested by the customer on the same Access Order and will be charged as set forth in Paragraph 7.4.10.

- Change of Access Carrier Name abbreviation (ACNA),
- Change of Billing Account Number (BAN) (e.g., a customer requests to aggregate all voice Grade(1) circuits on BAN), (CP)
- Change of customer Circuit Identification (CKR).

- (1) Effective June 30, 2021, this Service will no longer be available for purchase by new or existing customers. In addition, requests to move, add, change, or renew existing service arrangements will not be accepted. Following the expiration of a customer's existing term agreement, service will be provided on a month-to-month basis at the applicable Monthly rates until the service is discontinued. The Company currently plans to discontinue this service on or after June 30, 2024. (AT)

ACCESS SERVICES

7. SPECIAL ACCESS SERVICE-(Continued)

7.3 Rate Regulations-(Continued)

7.3.4 Minimum Periods

Except as specified otherwise, the minimum service period for all services is one month.

7.3.5 Moves

A move involves a change in the physical location of one of the following:

- The Point of Termination at the customer's premises
- The customer's premises

The charges are dependent on the type of move requested by the customer.

A. Moves of the Point of Termination Within the Same Customer Premises

(1) Rollover

A Rollover is a customer initiated move that involves a change of a Point of Termination from an existing service to another existing service within the same customer premises. The Rollover must occur within the same Telephone Company location.

Rollovers may be performed at the following service levels:

- Analog(1)/MegaLink Data(1) to 1.544 Mbps High Capacity (DS1) (CP)
- 1.544 Mbps High Capacity (DS1) to 1.544 High Capacity (DS1)
- 1.544 Mbps High Capacity (DS1) to MegaLink Custom (DS3)

- (1) Effective June 30, 2021, this Service will no longer be available for purchase by new or existing customers. In addition, requests to move, add, change, or renew existing service arrangements will not be accepted. Following the expiration of a customer's existing term agreement, service will be provided on a month-to-month basis at the applicable Monthly rates until the service is discontinued. The Company currently plans to discontinue this service on or after June 30, 2024. (AT)

ACCESS SERVICES

7. SPECIAL ACCESS SERVICE-(Continued)

7.3 Rate Regulations-(Continued)

7.3.7 Facility Hubs

A customer has the option of ordering voice grade(1) facilities of analog or digital high capacity facilities (i.e., Group, Supergroup, Mastergroup, DS1, DS1C, DS2, DS3 or DS4) to a facility Hub for channelizing to individual services requiring lower capacity facilities (i.e., Telegraph(1), Voice(1), Program Audio, etc.). (CP)

Different locations may be designated as Hubs for different facility capacities, i.e., multiplexing from digital to digital may occur at one location while multiplexing from digital to analog may occur at a different location. The customer will select the designated Hubs and their appropriate subtending wire center(s) from the National Exchange Carrier Association, Inc. Tariff filed with the F.C.C.

Some of the types of multiplexing available include the following:

- from higher to lower bit rate
- from higher to lower bandwidth
- from digital to voice frequency channels

End-to-end services may be provided on channels of these facilities to a Hub. The transmission performance for the end-to-end service provided customer designated premises will be that of the lower capacity or bit rate. For example, when a 1.544 Mbps facility is multiplexed to voice frequency channel, the transmission performance of the channelized services will be voice grade(1), not high capacity. (CP)

- (1) Effective June 30, 2021, this Service will no longer be available for purchase by new or existing customers. In addition, requests to move, add, change, or renew existing service arrangements will not be accepted. Following the expiration of a customer's existing term agreement, service will be provided on a month-to-month basis at the applicable Monthly rates until the service is discontinued. The Company currently plans to discontinue this service on or after June 30, 2024. (AT)

ACCESS SERVICES

7. SPECIAL ACCESS SERVICE-(Continued)

7.3 Rate Regulations-(Continued)

7.3.7 Facility Hubs-(Continued)

The Telephone Company will commence billing the monthly rate for the facility to the Hub on the date specified by the customer on the service order. Individual services utilizing these facilities may be installed coincident with the installation of the facility to the Hub, or may be ordered and/or installed at a later date, at the option of the customer. The customer will be billed for a voice grade(1) or a high capacity digital channel termination, channel mileage, when applicable, an Inside Wire Recovery Charge, if applicable, and the multiplexer at the time the facility is installed. Individual service rates, by service type, will apply for a channel termination, additional channel mileage, as required, and an Inside Wire Recovery Charge, if applicable, for each channelized service. These will be billed to the customer as each individual service is installed. The billing must be to the same customer for both parts of the service arrangement.

(CP)

Cascading multiplexing occurs when a high-capacity digital channel is de-multiplexed to provide channels with a lesser capacity and one of the lesser capacity channels is further de-multiplexed. For example, a supergroup facility is de-multiplexed to five group facilities and then one of the group facilities is further de-multiplexed to individual voice grade(1) channels.

(CP)

When cascading multiplexing is performed, whether in the same or a different Hub, a charge for the additional multiplexing unit also applies. When cascading multiplexing is performed at different Hubbing locations, channel mileage charges also apply between the Hubs.

- (1) Effective June 30, 2021, this Service will no longer be available for purchase by new or existing customers. In addition, requests to move, add, change, or renew existing service arrangements will not be accepted. Following the expiration of a customer's existing term agreement, service will be provided on a month-to-month basis at the applicable Monthly rates until the service is discontinued. The Company currently plans to discontinue this service on or after June 30, 2024.

(AT)

(AT)

ACCESS SERVICES

7. SPECIAL ACCESS SERVICE-(Continued)

7.3 Rate Regulations-(Continued)

7.3.8 Shared Use Analog and Digital High Capacity Services-(Continued)
the customer-designated premises will be dependent on the specific
type of Special Access Service that is provided (i.e., Voice Grade(1),
Telegraph(1), etc.) The applicable rates will include a Channel Termi-
nation rate, Channel Mileage rates, if applicable and an Inside Wire
Recovery Charge, if applicable. Rates for optional features and
functions, if any, associated with the service will apply as set forth
in 7.4 following.

(CP)
(CP)

7.3.9 Inside Wire Recovery Charge

The Inside Wire Recovery Charge is a charge to recover that portion
of inside wire cost that is assigned to Special Access Service. In-
side wire is as set forth in the Federal Communications Commission's
Rules and Regulations. Inside wire may be provided in association
with Metallic(1), Telegraph Grade(1), Voice Grade(1), and MegaLink Data(1) Channel
Terminations.

(CP)

Pursuant to CC Docket 83-1145 Memorandum Opinion and Order adopted
by the Federal Communications Commission on March 1, 1985, and re-
leased on March 8, 1985, the charge is assessed only to those cus-
tomers to whom such wiring is provided at a customer-designated
premises. Accordingly, the charge applies on a per Channel Termina-
tion basis for Metallic(1), Telegraph Grade(1), Voice Grade(1), (including WATS
Access Lines(1)) or MegaLink Data(1) Special Access Services unless
all such inside wire is provided by the customer.

(CP)
(CP)

The rate for the Inside Wire Recovery Charge is set forth in 7.4
following.

- (1) Effective June 30, 2021, this Service will no longer be available for purchase by new or existing
customers. In addition, requests to move, add, change, or renew existing service arrangements will
not be accepted. Following the expiration of a customer's existing term agreement, service will be
provided on a month-to-month basis at the applicable Monthly rates until the service is discontinued.
The Company currently plans to discontinue this service on or after June 30, 2024.

(AT)
|
(AT)

P.S.C. Mo. - No. 36
ACCESS SERVICES TARIFF

Southwestern Bell Telephone
Company d/b/a AT&T Missouri

Section 7
2nd Revised Sheet 75.2
Replacing 1st Revised Sheet 75.2

ACCESS SERVICES

7. SPECIAL ACCESS SERVICE-(Continued)

7.3 Rate Regulations-(Continued)

7.3.10 WATS Access Line Service (WALs)(1)

(CP)

When WATS Access Lines are provided the Voice Grade(1) rate elements which apply are WAL Channel Termination (CT) between the customer designated premises and the serving wire center associated with that premises and Channel Mileage (CM) between the serving wire center associated with a customer designated premises and the WATS serving office (when the serving wire center is not a WATS serving office). In addition, the Inside Wire Charge (where appropriate), Special Access Line Surcharge and Message Station Equipment Recovery Charge will apply. (CP)

When extensions (i.e., additional terminations of the service at a different premises in the same or a different LATA) are provided, they are rated in the following manner. Both interLATA and intra-LATA extensions require an additional WAL Channel Termination and Channel Mileage (as needed). In addition, the Inside Wire Charge (where appropriate), Special Access Line Surcharge and Message Station Equipment Recovery Charge will apply.

- (1) Effective June 30, 2021, this Service will no longer be available for purchase by new or existing customers. In addition, requests to move, add, change, or renew existing service arrangements will not be accepted. Following the expiration of a customer's existing term agreement, service will be provided on a month-to-month basis at the applicable Monthly rates until the service is discontinued. The Company currently plans to discontinue this service on or after June 30, 2024.

(AT)

(AT)

**P.S.C. Mo. - No. 36
ACCESS SERVICES TARIFF**

Southwestern Bell Telephone
Company d/b/a AT&T Missouri

Section 7
3rd Revised Sheet 75.6
Replacing 2nd Revised Sheet 75.6

1st Revised Sheet 75.6 was formerly 1st Revised Sheet 75.06 (AT)

ACCESS SERVICES

7. SPECIAL ACCESS SERVICE-(Continued)

7.3 Rate Regulations-(Continued)

7.3.12 MegaLink Data(1) and High Capacity Services (CP)

A. Rate Bands

MegaLink Data(1) and High Capacity Services Channel Termination and Channel Mileage rates will fall within a lower and upper rate band. Only the monthly rates will fall within these rate bands. Written notice of rate change(s) and its effective date will be sent to the Commission within ten (10) days after the effective date. The rate bands are as follows: (CP)

1. MegaLink Data(1) Service Lower Band Upper Band (CP)

a. Channel Termination

	57.00	94.00		(RT)
4.8 kbps				
9.6 kbps	60.00	92.95		
56.0 kbps	115.00	171.35		

b. Channel Mileage Fixed

	None	None		(RT)
4.8 kbps				
Mileage Bands				
0	None	None		
Over 0 to 4	42.75	63.65		
Over 4 to 8	42.75	63.65		
Over 8 to 25	42.75	68.85		
Over 25 to 50	42.75	69.85		
Over 50	42.75	69.85		

(1) Effective June 30, 2021, this Service will no longer be available for purchase by new or existing customers. In addition, requests to move, add, change, or renew existing service arrangements will not be accepted. Following the expiration of a customer's existing term agreement, service will be provided on a month-to-month basis at the applicable Monthly rates until the service is discontinued. The Company currently plans to discontinue this service on or after June 30, 2024. (AT)

**P.S.C. Mo. - No. 36
ACCESS SERVICES TARIFF**

Southwestern Bell Telephone
Company d/b/a AT&T Missouri

Section 7
3rd Revised Sheet 75.8
Replacing 2nd Revised Sheet 75.8

1st Revised Sheet 75.8 was formerly 1st Revised Sheet 75.08 (AT)

ACCESS SERVICES

7. SPECIAL ACCESS SERVICE-(Continued)

7.3 Rate Regulations-(Continued)

7.3.12 MegaLink Data(1) and High Capacity Services-(Continued) (CP)

A. Rate Bands-(Continued)

1. MegaLink Data(1) Service-(Continued) (CP)

	<u>Lower Band</u>	<u>Upper Band</u>
--	-------------------	-------------------

c. Channel Mileage Per Mile-(Continued)

4.8 kbps		
Mileage Bands		
0	None	None
Over 0 to 4	\$ 0.62	\$1.70
Over 4 to 8	0.62	1.70
Over 8 to 25	0.62	1.05
Over 25 to 50	0.62	1.00
Over 50	0.62	1.00

9.6 kbps		
Mileage Bands		
0	None	None
Over 0 to 4	1.10	2.65
Over 4 to 8	1.10	2.65
Over 8 to 25	1.10	2.10
Over 25 to 50	1.10	2.00
Over 50	1.10	2.00

56 kbps		
Mileage Bands		
0	None	None
Over 0 to 4	3.00	8.10
Over 4 to 8	3.00	5.55
Over 8 to 25	3.00	3.60
Over 25 to 50	3.00	3.60
Over 50	3.00	3.60

(1) Effective June 30, 2021, this Service will no longer be available for purchase by new or existing customers. In addition, requests to move, add, change, or renew existing service arrangements will not be accepted. Following the expiration of a customer's existing term agreement, service will be provided on a month-to-month basis at the applicable Monthly rates until the service is discontinued. The Company currently plans to discontinue this service on or after June 30, 2024. (AT)

**P.S.C. Mo. - No. 36
ACCESS SERVICES TARIFF**

Southwestern Bell Telephone
Company d/b/a AT&T Missouri

Section 7
3rd Revised Sheet 75.9
Replacing 2nd Revised Sheet 75.9

1st Revised Sheet 75.9 was formerly 1st Revised Sheet 75.09 (AT)

ACCESS SERVICES

7. SPECIAL ACCESS SERVICE-(Continued)

7.3 Rate Regulations-(Continued)

7.3.12 MegaLink Data(1) and High Capacity Services-(Continued) (CP)

A. Rate Bands-(Continued)

2. High Capacity Service Lower Band Upper Band

a. Channel Termination

1.544 Mbps	\$147.88	\$225.00
------------	----------	----------

b. Channel Mileage Fixed

1.544 Mbps		
Mileage Bands		
0	None	None
Over 0 to 4	46.00	100.00
Over 4 to 8	46.00	100.00
Over 8 to 25	46.00	80.00
Over 25 to 50	46.00	80.00
Over 50	46.00	80.00

c. Channel Mileage Per Mile

1.544 Mbps		
Mileage Bands		
0	None	None
Over 0 to 4	25.00	50.00
Over 4 to 8	25.00	60.00
Over 8 to 25	25.00	60.00
Over 25 to 50	25.00	60.00
Over 50	25.00	60.00

(1) Effective June 30, 2021, this Service will no longer be available for purchase by new or existing customers. In addition, requests to move, add, change, or renew existing service arrangements will not be accepted. Following the expiration of a customer's existing term agreement, service will be provided on a month-to-month basis at the applicable Monthly rates until the service is discontinued. The Company currently plans to discontinue this service on or after June 30, 2024. (AT)

|
(AT)

**P.S.C. Mo. - No. 36
ACCESS SERVICES TARIFF**

Southwestern Bell Telephone
Company d/b/a AT&T Missouri

Section 7
6th Revised Sheet 76
Replacing 5th Revised Sheet 76

ACCESS SERVICES

7. SPECIAL ACCESS SERVICE-(Continued)

7.4 Rates and Charges

7.4.1 Metallic(1) Service

(CP)

	<u>USOC</u>	<u>Monthly Rates</u>	<u>Nonrecurring Charges</u>	
			<u>1st Ckt</u>	<u>Addl. Ckt</u>
A. Channel Termination				
- Per point of termination	T6ECS	\$24.00	113.00	77.00
1. Inside wire charge				
- Per Channel Termination	WMJ	None	None	

B. Channel Mileage

<u>Mileage Bands</u>	<u>USOC</u>	<u>Monthly Rates</u>	
		<u>Fixed</u>	<u>Per Mile</u>
0	1L5XX	None	None
Over 0 to 4	1L5XX	\$12.00	.59
Over 4 to 8	1L5XX	12.00	2.20
Over 8 to 25	1L5XX	11.00	3.28
Over 25 to 50	1L5XX	11.00	3.28
Over 50	1L5XX	11.00	3.28

	<u>USOC</u>	<u>Monthly Rates</u>	<u>Nonrecurring Charges</u>
C. Optional Features, BSEs and Functions			
1. Bridging			
a. Three Premises Bridging			
- Per port	BCNM3	\$5.35	None
b. Series Bridging			
- Per port	BCNMS	5.35	None

(1) Effective June 30, 2021, this Service will no longer be available for purchase by new or existing customers. In addition, requests to move, add, change, or renew existing service arrangements will not be accepted. Following the expiration of a customer's existing term agreement, service will be provided on a month-to-month basis at the applicable Monthly rates until the service is discontinued. The Company currently plans to discontinue this service on or after June 30, 2024.

(AT)
|
(AT)

**P.S.C. Mo. - No. 36
ACCESS SERVICES TARIFF**

Southwestern Bell Telephone
Company d/b/a AT&T Missouri

Section 7
6th Revised Sheet 77
Replacing 5th Revised Sheet 77

ACCESS SERVICES

7. SPECIAL ACCESS SERVICE-(Continued)

7.4 Rates and Charges-(Continued)

7.4.2 Telegraph Grade(1) Service

(CP)

	<u>USOC</u>	<u>Monthly Rates</u>	<u>Nonrecurring Charges</u>	
			<u>1st Ckt</u>	<u>Addl. Ckt</u>
A. Channel Termination				
- Per point of termination				
- Two-Wire	T6E2X	\$38.00	167.00	121.00
- Four-Wire	T6E4X	64.25	167.00	121.00
1. Inside Wire Charge				
- Per Channel Termination	WMJ	None		None

B. Channel Mileage

<u>Mileage Bands</u>	<u>USOC</u>	<u>Monthly Rates</u>	
		<u>Fixed</u>	<u>Per Mile</u>
0	1L5XX	None	None
Over 0 to 4	1L5XX	\$22.75	\$5.80
Over 4 to 8	1L5XX	22.00	5.80
Over 8 to 25	1L5XX	22.00	5.80
Over 25 to 50	1L5XX	23.25	5.80
Over 50	1L5XX	61.00	4.95

	<u>USOC</u>	<u>Monthly Rates</u>	<u>Nonrecurring Charges</u>
1. Telegraph Bridging			
Two-Wire and Four-Wire			
- Per port			
- Two-Wire	BCNT2	\$6.60	None
- Four-Wire	BCNT4	6.60	None

(1) Effective June 30, 2021, this Service will no longer be available for purchase by new or existing customers. In addition, requests to move, add, change, or renew existing service arrangements will not be accepted. Following the expiration of a customer's existing term agreement, service will be provided on a month-to-month basis at the applicable Monthly rates until the service is discontinued. The Company currently plans to discontinue this service on or after June 30, 2024.

(AT)
|
(AT)

**P.S.C. Mo. - No. 36
ACCESS SERVICES TARIFF**

Southwestern Bell Telephone
Company d/b/a AT&T Missouri

Section 7
6th Revised Sheet 78
Replacing 5th Revised Sheet 78

ACCESS SERVICES

7. SPECIAL ACCESS SERVICE-(Continued)

7.4 Rates and Charges-(Continued)

7.4.3 Voice Grade(1) Service (CP)

	<u>USOC</u>	<u>Monthly Rates</u>	<u>Nonrecurring Charges</u>		
			<u>1st Ckt</u>	<u>Addl. Ckt</u>	
A. Channel Termination					
- Per point of termination					
- Two-Wire	T6E2X	\$27.75	\$153.00	113.00	
- Four-Wire	T6E4X	63.75	175.00	129.00	
- Digital WATS Access Line (WAL)*(1)	T6EDX	5.95	134.00	95.00	(CP)
			<u>Nonrecurring Charges</u>		
- Non-jointly provided WATS Access Line (WAL)(1) two-wire	X2H	41.25		75.00	(CP)
- Non-jointly provided WATS Access Line (WAL)(1) four-wire	X4H	65.75		75.00	(CP)
1. Inside Wire Charge					
- Per Channel Termination	WMJ	None		None	

B. Channel Mileage

<u>Mileage Bands</u>	<u>USOC</u>	<u>Monthly Rates</u>	
		<u>Fixed</u>	<u>Per Mile</u>
0	1L5XX	None	None
Over 0 to 4	1L5XX	\$20.00	\$5.30
Over 4 to 8	1L5XX	19.50	5.30
Over 8 to 25	1L5XX	19.00	5.30
Over 25 to 50	1L5XX	18.75	5.30
Over 50	1L5XX	55.75	4.49

*Additive applicable in conjunction with customer ordered Digital High Capacity facility in Paragraph 7.4.7.

(1) Effective June 30, 2021, this Service will no longer be available for purchase by new or existing customers. In addition, requests to move, add, change, or renew existing service arrangements will not be accepted. Following the expiration of a customer's existing term agreement, service will be provided on a month-to-month basis at the applicable Monthly rates until the service is discontinued. The Company currently plans to discontinue this service on or after June 30, 2024. (AT)

**P.S.C. Mo. - No. 36
ACCESS SERVICES TARIFF**

Southwestern Bell Telephone
Company d/b/a AT&T Missouri

Section 7
6th Revised Sheet 78.1
Replacing 5th Revised Sheet 78.1

ACCESS SERVICES

7. SPECIAL ACCESS SERVICE-(Continued)

7.4 Rates and Charges-(Continued)

7.4.3 Voice Grade Service(1)-(Continued)

(CP)

	<u>USOC</u>	<u>Monthly Rates</u>	<u>Nonrecurring Charges</u>	
			<u>1st Ckt</u>	<u>Addl. Ckt</u>
C. Analog Service to Service Through Connect Arrangement				
Multiplexed Arrangement (Derived from a DS1 multiplexer)				
THK		8.05	98.00	87.00
D. Optional Features, BSEs and Functions				
			<u>Nonrecurring Charges</u>	
1. Bridging				
a. Voice Bridging				
Two-Wire/Four-Wire				
- Per port				
	BCNV2	\$5.30	None	
	BCNV4	5.30	None	

(1) Effective June 30, 2021, this Service will no longer be available for purchase by new or existing customers. In addition, requests to move, add, change, or renew existing service arrangements will not be accepted. Following the expiration of a customer's existing term agreement, service will be provided on a month-to-month basis at the applicable Monthly rates until the service is discontinued. The Company currently plans to discontinue this service on or after June 30, 2024.

(AT)
|
(AT)

**P.S.C. Mo. - No. 36
ACCESS SERVICES TARIFF**

Southwestern Bell Telephone
Company d/b/a AT&T Missouri

Section 7
6th Revised Sheet 79
Replacing 5th Revised Sheet 79

ACCESS SERVICES

7. SPECIAL ACCESS SERVICE-(Continued)

7.4 Rates and Charges-(Continued)

7.4.3 Voice Grade(1) Service-(Continued) (CP)

	<u>USOC</u>	<u>Monthly Rates</u>	<u>Nonrecurring Charges</u>
D. Optional Features, BSEs and Functions-(Continued)			
1. Bridging-(Continued)			
b. Data Bridging			
Two-Wire/Four-Wire			
- Per port			
- Two-Wire	BCND2	\$ 5.30	None
- Four-Wire	BCND4	5.30	None

(RT)
|
(RT)

(1) Effective June 30, 2021, this Service will no longer be available for purchase by new or existing customers. In addition, requests to move, add, change, or renew existing service arrangements will not be accepted. Following the expiration of a customer's existing term agreement, service will be provided on a month-to-month basis at the applicable Monthly rates until the service is discontinued. The Company currently plans to discontinue this service on or after June 30, 2024. (AT)
|
(AT)

**P.S.C. Mo. - No. 36
ACCESS SERVICES TARIFF**

Southwestern Bell Telephone
Company d/b/a AT&T Missouri

Section 7
6th Revised Sheet 80
Replacing 5th Revised Sheet 80

ACCESS SERVICES

7. SPECIAL ACCESS SERVICE-(Continued)

7.4 Rates and Charges-(Continued)

7.4.3 Voice Grade(1) Service-(Continued)

(CP)

	<u>USOC</u>	<u>Monthly Rates</u>	<u>Nonrecurring Charges</u>
D. Optional Features, BSEs and Functions-(Continued)			

1. Bridging-(Continued)

(RT)

d. Telemetry and Alarm
Bridging

(RT)

Active Bridging
Channel Connections

Split Band

- Per channel
connected

CNLRX

2.10

None

Summation

- Per channel
connected

BCNSA

3.19

None

(1) Effective June 30, 2021, this Service will no longer be available for purchase by new or existing customers. In addition, requests to move, add, change, or renew existing service arrangements will not be accepted. Following the expiration of a customer's existing term agreement, service will be provided on a month-to-month basis at the applicable Monthly rates until the service is discontinued. The Company currently plans to discontinue this service on or after June 30, 2024.

(AT)

(AT)

**P.S.C. Mo. - No. 36
ACCESS SERVICES TARIFF**

Southwestern Bell Telephone
Company d/b/a AT&T Missouri

Section 7
7th Revised Sheet 81
Replacing 6th Revised Sheet 81

ACCESS SERVICES

7. SPECIAL ACCESS SERVICE-(Continued)

7.4 Rates and Charges-(Continued)

7.4.3 Voice Grade(2) Service-(Continued) (CP)

	<u>USOC</u>	<u>Monthly Rates</u>	<u>Nonrecurring Charges</u>	
D. Optional Features, BSEs and Functions-(Continued)				
1. Bridging-(Continued)				
d. Telemetry and Alarm Bridging-(Continued)				
Passive Bridging Channel Connections				
- Per channel connected	BCNTP	\$.83	None	
2. Conditioning				
- Per point of termination				
C-Type(1)	X1CPT	42.25	None	
C-Conditioning		.27	None	
Sealing Current				
- Per point of termination	1HBPT	None	None	
3. Improved Attenuation Distortion (IAD)				
- Per WAL(2) point of termination	ORA	6.90	177.00	(CP)
- Per point of termination	UHW	.54	None	

(1) This feature is obsolete, and limited to existing installations at existing locations, for existing customers.
(2) Effective June 30, 2021, this Service will no longer be available for purchase by new or existing customers. (AT)
In addition, requests to move, add, change, or renew existing service arrangements will not be accepted.
Following the expiration of a customer's existing term agreement, service will be provided on a month-to-month basis at the applicable Monthly rates until the service is discontinued. The Company currently plans to discontinue this service on or after June 30, 2024. (AT)

**P.S.C. Mo. - No. 36
ACCESS SERVICES TARIFF**

Southwestern Bell Telephone
Company d/b/a AT&T Missouri

Section 7
7th Revised Sheet 82
Replacing 6th Revised Sheet 82

ACCESS SERVICES

7. SPECIAL ACCESS SERVICE-(Continued)

7.4 Rates and Charges-(Continued)

7.4.3 Voice Grade(1) Service-(Continued)

	<u>USOC</u>	<u>Monthly Rates</u>	<u>Nonrecurring Charges</u>	
D. Optional Features, BSEs and Functions-(Continued)				
4. Improved Return Loss				
- Per two-wire point of termination	1RL2W	\$5.40	None	
5. Improved Termination				
- Per four-wire point of termination	1RI4W	5.40	None	
6. Improved Echo Control				
- Per Two-Wire WAL(1) point of termination	ORH	None	\$172.00	(CP)
7. Improved equal Level Echo Path Loss				
- Per Point of termination	UHZ	None	None	
8. Multiplexing				
Voice to Telegraph Grade (43-Type Carrier)(1)				(CP)
- Per arrangement	MQX	52.20	None	
9. Data Capability				
- Per point of termination	XDCPT	7.25	\$236.00	
10. Improved Envelope Delay Distortion (IEDD)				
- per point of termination	UHY	47.90	None	

(1) Effective June 30, 2021, this Service will no longer be available for purchase by new or existing customers. In addition, requests to move, add, change, or renew existing service arrangements will not be accepted. Following the expiration of a customer's existing term agreement, service will be provided on a month-to-month basis at the applicable Monthly rates until the service is discontinued. The Company currently plans to discontinue this service on or after June 30, 2024. (AT)

Issued: May 28, 2021

By CRAIG UNRUH, President - Missouri
St. Louis, Missouri

Effective: June 30, 2021

**P.S.C. Mo. - No. 36
ACCESS SERVICES TARIFF**

Southwestern Bell Telephone
Company d/b/a AT&T Missouri

Section 7
7th Revised Sheet 83
Replacing 6th Revised Sheet 83

ACCESS SERVICES

7. SPECIAL ACCESS SERVICE-(Continued)

7.4 Rates and Charges-(Continued)

7.4.3 Voice Grade(1) Service-(Continued)

(CP)

	<u>USOC</u>	<u>Monthly Rates</u>	<u>Nonrecurring Charges</u>
D. Optional Features, BSEs and Functions-(Continued)			
11. Signaling Capability			
- Per point of termination	XSS++	\$20.75	None
- In lieu of ++, substitute appropriate two digit code from following list to specify type of signaling.			
AB			
AC			
CT			
DX			
DY			
EA			
EB			
EC			
EX			
GO			
GS			
LA			
LB			
LC			
LO			
LR			
LS			
RV			
SF			

(1) Effective June 30, 2021, this Service will no longer be available for purchase by new or existing customers. In addition, requests to move, add, change, or renew existing service arrangements will not be accepted. Following the expiration of a customer's existing term agreement, service will be provided on a month-to-month basis at the applicable Monthly rates until the service is discontinued. The Company currently plans to discontinue this service on or after June 30, 2024.

(AT)
|
(AT)

**P.S.C. Mo. - No. 36
ACCESS SERVICES TARIFF**

Southwestern Bell Telephone
Company d/b/a AT&T Missouri

Section 7
6th Revised Sheet 84
Replacing 5th Revised Sheet 84

ACCESS SERVICES

7. SPECIAL ACCESS SERVICE-(Continued)

7.4 Rates and Charges-(Continued)

7.4.3 Voice Grade(3) Service-(Continued) (CP)

	<u>USOC</u>	<u>Monthly Rates</u>	<u>Nonrecurring Charges</u>
D. Optional Features, BSEs and Functions-(Continued)			
12. Selective Signaling Arrangement			
Per point of termination	USZ	\$15.90	None
13. Transfer Arrangement (key activated(1))			
Per four port arrangement including control channel termination(2)	USY	32.10	None
Per five port arrangement including control channel termination(2)	US5	28.70	None

- (1) The key activated control channel is rated as a metallic channel termination (use USOC T6EME in lieu of T6ECS) and channel mileage, if applicable (use USOC 1L5MX in lieu of 1L5XX).
- (2) An additional Channel Termination Charge will apply whenever a spare channel is configured as a leg to the customer premises. Additional Channel Mileage Charges will also apply when the transfer arrangement is not located in the customer premises serving wire center.
- (3) Effective June 30, 2021, this Service will no longer be available for purchase by new or existing customers. In addition, requests to move, add, change, or renew existing service arrangements will not be accepted. Following the expiration of a customer's existing term agreement, service will be provided on a month-to-month basis at the applicable Monthly rates until the service is discontinued. The Company currently plans to discontinue this service on or after June 30, 2024.

(AT)
|
(AT)

**P.S.C. Mo. - No. 36
ACCESS SERVICES TARIFF**

Southwestern Bell Telephone
Company d/b/a AT&T Missouri

Section 7
7th Revised Sheet 93
Replacing 6th Revised Sheet 93

ACCESS SERVICES

7. SPECIAL ACCESS SERVICE-(Continued)

7.4 Rates and Charges-(Continued)

7.4.6 MegaLink Data(2) Service

(CP)

	<u>USOC</u>	<u>Monthly Rates</u>	<u>Nonrecurring Charges</u>	
			<u>1st Ckt</u>	<u>Addl. Ckt</u>
A. Channel Termination				
- Per point of termination				
(RT)				
- 4.8 kbps(1)				
- 9.6 kbps(1)				
- 19.2 kbps	T6ECS	132.15	273.00	208.00
- 56.0 kbps(1)				
- 64.0 kbps (CC)	T6ECS	197.05	324.00	247.00

			<u>Nonrecurring Charges</u>	
1. Inside Wire Charge				
- Per Channel Termination				
	WMJ	None	None	

	<u>USOC</u>	<u>Monthly Rates</u>	
		<u>Fixed</u>	<u>Per Mile</u>

B. Channel Mileage

1. 2.4 kbps(1)

(1) See Supplemental Schedule for current effective rates.

(2) Effective June 30, 2021, this Service will no longer be available for purchase by new or existing customers. In addition, requests to move, add, change, or renew existing service arrangements will not be accepted. Following the expiration of a customer's existing term agreement, service will be provided on a month-to-month basis at the applicable Monthly rates until the service is discontinued. The Company currently plans to discontinue this service on or after June 30, 2024.

(AT)
|
(AT)

**P.S.C. Mo. - No. 36
ACCESS SERVICES TARIFF**

Southwestern Bell Telephone
Company d/b/a AT&T Missouri

Section 7
5th Revised Sheet 94
Replacing 4th Revised Sheet 94

ACCESS SERVICES

7. SPECIAL ACCESS SERVICE-(Continued)

7.4 Rates and Charges-(Continued)

7.4.6 MegaLink Data(2) Service-(Continued)

(C)(CP)

USOC	Monthly Rates	
	Fixed	Per Mile

B. Channel Mileage-(Continued)

2. 4.8 kbps(1)

3. 9.6 kbps(1)

4. 19.2 kbps

Mileage Bands

0	1L5XX	None	None
Over 0 to 4	1L5XX	\$126.30	\$2.85
Over 4 to 8	1L5XX	126.30	2.85
Over 8 to 25	1L5XX	126.30	2.85
Over 25 to 50	1L5XX	126.30	2.85
Over 50	1L5XX	126.30	2.85

(1) See Supplemental Schedule for current effective rates.

(2) Effective June 30, 2021, this Service will no longer be available for purchase by new or existing customers. In addition, requests to move, add, change, or renew existing service arrangements will not be accepted. Following the expiration of a customer's existing term agreement, service will be provided on a month-to-month basis at the applicable Monthly rates until the service is discontinued. The Company currently plans to discontinue this service on or after June 30, 2024.

(AT)
|
(AT)

**P.S.C. Mo. - No. 36
ACCESS SERVICES TARIFF**

Southwestern Bell Telephone
Company d/b/a AT&T Missouri

Section 7
9th Revised Sheet 95
Replacing 8th Revised Sheet 95

ACCESS SERVICES

7. SPECIAL ACCESS SERVICE-(Continued)

7.4 Rates and Charges-(Continued)

7.4.6 MegaLink Data(2) Service-(Continued)

(CP)

	<u>USOC</u>	<u>Monthly Rates</u>	
		<u>Fixed</u>	<u>Per Mile</u>
B. Channel Mileage-(Continued)			
5. 56 kbps(1)			
6. 64 kbps (CC)			
<u>Mileage Bands</u>			
0	1L5XX	None	None
Over 0 to 4	1L5XX	\$184.75	\$ 9.35
Over 4 to 8	1L5XX	184.75	9.35
Over 8 to 25	1L5XX	184.75	9.35
Over 25 to 50	1L5XX	184.75	9.35
Over 50	1L5XX	184.75	9.35

	<u>USOC</u>	<u>Monthly Rates</u>	<u>Nonrecurring Charges</u>	
			<u>1st Ckt</u>	<u>Addl. Ckt</u>
C. Service to Service Through Connect Arrangement				
Interconnection of two subtending digital channels (Derived from DS1 multi-plexers)				
	THK	None	\$91.00	\$81.00

D. Optional Features, BSEs and Functions

	<u>Nonrecurring Charges</u>		
1. Bridging			
- Per port	BCNDA	\$19.50	None

(1) See Supplemental Schedule for current effective rates.

(2) Effective June 30, 2021, this Service will no longer be available for purchase by new or existing customers. In addition, requests to move, add, change, or renew existing service arrangements will not be accepted. Following the expiration of a customer's existing term agreement, service will be provided on a month-to-month basis at the applicable Monthly rates until the service is discontinued. The Company currently plans to discontinue this service on or after June 30, 2024.

(AT)
|
(AT)

**P.S.C. Mo. - No. 36
ACCESS SERVICES TARIFF**

Southwestern Bell Telephone
Company d/b/a AT&T Missouri

Section 7
5th Revised Sheet 96
Replacing 4th Revised Sheet 96

ACCESS SERVICES

7. SPECIAL ACCESS SERVICE-(Continued)

7.4 Rates and Charges-(Continued)

7.4.6 MegaLink Data(4) Service-(Continued)

(CP)

D. Optional Features, BSEs and Functions-(Continued)

	<u>USOC</u>	<u>Monthly Rates</u>	<u>Nonrecurring Charges</u>
2. Loop Transfer Arrangement (key activated(1)) - Per four port arrangement(2)	XTD	\$64.25	\$40.00
3. Secondary Channel Capability - Per Channel termination	SCA	12.00	125.00(3)

(1) The key activated control channel is rated as a metallic channel termination (use USOC T6EME in lieu of T6ECS) and channel mileage, if applicable (use USOC 1L5MX in lieu of 1L5XX).

(2) An additional Channel Termination Charge will apply whenever a spare channel is configured as a leg to the customer's premises. Additional channel mileage charges will also apply when the transfer arrangement is not located in the customer premises serving wire center.

(3) Nonrecurring charge applies only if secondary channel capability is installed subsequent to initial installation of MegaLink channel termination.

(4) Effective June 30, 2021, this Service will no longer be available for purchase by new or existing customers. (AT)
In addition, requests to move, add, change, or renew existing service arrangements will not be accepted. Following the expiration of a customer's existing term agreement, service will be provided on a month-to-month basis at the applicable Monthly rates until the service is discontinued. The Company currently plans to discontinue this service on or after June 30, 2024. (AT)

**P.S.C. Mo. - No. 36
ACCESS SERVICES TARIFF**

Southwestern Bell Telephone
Company d/b/a AT&T Missouri

Section 7
1st Revised Sheet 96.1
Replacing Original Sheet 96.1

ACCESS SERVICES

MEGALINK DATA(1) SERVICE

(CP)

	<u>USOC</u>	<u>Monthly Rates</u>	<u>Nonrecurring Charges</u>	
			<u>1st Ckt</u>	<u>Addl. Ckt</u>
A. Channel Termination				
- Per point of termination				

- 4.8 kbps	T6ECS	94.00	279.00	213.00	(RT)
- 9.6 kbps	T6ECS	92.95	274.00	209.00	
- 56.0 kbps	T6ECS	171.35	324.00	249.00	

	<u>USOC</u>	<u>Monthly Rates</u>	
		<u>Fixed</u>	<u>Per Mile</u>
B. Channel Mileage			

1. 2.4 kbps

Mileage Bands

0	1L5XX	None	None
Over 0 to 4	1L5XX	\$62.75	\$2.25
Over 4 to 8	1L5XX	67.00	1.20
Over 8 to 25	1L5XX	70.45	.75
Over 25 to 50	1L5XX	73.85	.60
Over 50	1L5XX	76.85	.55

2. 4.8 kbps

Mileage Bands

0	1L5XX	None	None
Over 0 to 4	1L5XX	\$ 63.65	\$1.70
Over 4 to 8	1L5XX	63.65	1.70
Over 8 to 25	1L5XX	68.85	1.05
Over 25 to 50	1L5XX	69.85	1.00
Over 50	1L5XX	69.85	1.00

Pursuant to Section 392.510.3, R.S.Mo. 1994

(1) Effective June 30, 2021, this Service will no longer be available for purchase by new or existing customers. (AT)
In addition, requests to move, add, change, or renew existing service arrangements will not be accepted.
Following the expiration of a customer's existing term agreement, service will be provided on a month-to-month basis at the applicable Monthly rates until the service is discontinued. The Company currently plans to discontinue this service on or after June 30, 2024. (AT)

Issued: May 28, 2021

By CRAIG UNRUH, President - Missouri
St. Louis, Missouri

Effective: June 30, 2021

**P.S.C. Mo. - No. 36
ACCESS SERVICES TARIFF**

Southwestern Bell Telephone
Company d/b/a AT&T Missouri

Section 7
1st Revised Sheet 96.2
Replacing Original Sheet 96.2

ACCESS SERVICES

MEGALINK DATA(1) SERVICE

(CP)

	<u>USOC</u>	<u>Monthly Rates</u>	
		<u>Fixed</u>	<u>Per Mile</u>
B. Channel Mileage-(Continued)			
3. 9.6 kbps			
<u>Mileage Bands</u>			
0	1L5XX	None	None
Over 0 to 4	1L5XX	\$ 87.55	\$2.65
Over 4 to 8	1L5XX	87.75	2.65
Over 8 to 25	1L5XX	91.95	2.10
Over 25 to 50	1L5XX	94.55	2.00
Over 50	1L5XX	94.55	2.00

4. 56 kbps

Mileage Bands

0	1L5XX	None	None
Over 0 to 4	1L5XX	\$134.85	\$8.10
Over 4 to 8	1L5XX	145.15	5.55
Over 8 to 25	1L5XX	160.65	3.60
Over 25 to 50	1L5XX	160.65	3.60
Over 50	1L5XX	161.00	3.60

Pursuant to Section 392.510.3, R.S.Mo. 1994

(1) Effective June 30, 2021, this Service will no longer be available for purchase by new or existing customers. (AT)
In addition, requests to move, add, change, or renew existing service arrangements will not be accepted.
Following the expiration of a customer's existing term agreement, service will be provided on a month-to-month basis at the applicable Monthly rates until the service is discontinued. The Company currently plans to discontinue this service on or after June 30, 2024. (AT)

Issued: May 28, 2021

By CRAIG UNRUH, President - Missouri
St. Louis, Missouri

Effective: June 30, 2021

**P.S.C. Mo. - No. 36
ACCESS SERVICES TARIFF**

Southwestern Bell Telephone
Company d/b/a AT&T Missouri

Section 7
8th Revised Sheet 97
Replacing 7th Revised Sheet 97

ACCESS SERVICES

7. SPECIAL ACCESS SERVICE-(CONTINUED)

7.4 Rates and Charges-(Continued)

7.4.7 High Capacity Service

	<u>USOC</u>	<u>Monthly Rates</u>	<u>Nonrecurring Charges</u>	
			<u>1st Ckt</u>	<u>Addl. Ckt</u>
A. Channel Termination				
- Per point of termination				
- 1.544 Mbps(1)				
- 44.736 Mbps	TWT++	ICB	ICB	ICB

	<u>USOC</u>	<u>Monthly Rates</u>	
		<u>Fixed</u>	<u>Per Mile</u>

B. Channel Mileage

1. 64 Kbps(2)(3)

(CP)

Mileage Bands

0	1L5TC	None	None
Over 0 to 4	1L5XX	56.65	\$2.50
Over 4 to 8	1L5XX	57.50	2.40
Over 8 to 25	1L5XX	57.60	2.40
Over 25 to 50	1L5XX	57.00	2.35
Over 50	1L5XX	57.00	2.35

(1) See Supplemental Schedule for current effective rates.

(2) Available only as a channel of a 1.544 Mbps facility to a SWBT Digital Data Hub or as a cross connect of two channels of two 1.544 Mbps facilities to a Digital Data Hub(s). The customer must provide system and channel assignment data.

(3) Effective June 30, 2021, this Service will no longer be available for purchase by new or existing customers. In addition, requests to move, add, change, or renew existing service arrangements will not be accepted. Following the expiration of a customer's existing term agreement, service will be provided on a month-to-month basis at the applicable Monthly rates until the service is discontinued. The Company currently plans to discontinue this service on or after June 30, 2024.

(AT)
|
(AT)

**P.S.C. Mo. - No. 36
ACCESS SERVICES TARIFF**

Southwestern Bell Telephone
Company d/b/a AT&T Missouri

Section 7
6th Revised Sheet 100
Replacing 5th Revised Sheet 100

ACCESS SERVICES

7. SPECIAL ACCESS SERVICE-(Continued)

7.4 Rates and Charges-(Continued)

7.4.7 High Capacity Service-(Continued)

	<u>USOC</u>	<u>Monthly Rates</u>	<u>Nonrecurring Charges</u>
D. Optional Features, BSEs and Functions			

1. Multiplexing

DS3 to DS1

- Per arrangement	MXB++	ICB	None
-------------------	-------	-----	------

DS1 to Voice(1)

- Per arrangement	MQ1	\$200.00	None
-------------------	-----	----------	------

DS1 to DSO

- Per arrangement	QMU	600.00	None
-------------------	-----	--------	------

DSO to Subrates(2)

- Per arrangement

(CP)

- Up to twenty 2.4 kbps services

	QSU24	147.00	None
--	-------	--------	------

- Up to ten 4.8 kbps services

	QSU48	291.20	None
--	-------	--------	------

- Up to five 9.6 kbps services

	QSU96	556.30	None
--	-------	--------	------

(1) A channel of this DS1 to the Hub can be used for a MegaLink Data Service.

(2) Effective June 30, 2021, this Service will no longer be available for purchase by new or existing customers. In addition, requests to move, add, change, or renew existing service arrangements will not be accepted. Following the expiration of a customer's existing term agreement, service will be provided on a month-to-month basis at the applicable Monthly rates until the service is discontinued. The Company currently plans to discontinue this service on or after June 30, 2024.

(AT)

(AT)

**P.S.C. Mo. - No. 36
ACCESS SERVICES TARIFF**

Southwestern Bell Telephone
Company d/b/a AT&T Missouri

Section 7
6th Revised Sheet 101
Replacing 5th Revised Sheet 101

ACCESS SERVICES

7. SPECIAL ACCESS SERVICE-(Continued)

7.4 Rates and Charges-(Continued)

7.4.7 High Capacity Service-(Continued)

	<u>USOC</u>	<u>Monthly Rates</u>	<u>Nonrecurring Charges</u>
D. Optional Features, BSEs and Functions-(Continued)			
2.			
3. Transfer Arrangement (key activated(2)(5))			
- Per four port arrangement including control channel termination(3)	USV	241.50	235.00
4. Clear Channel Capability			
- Per 1.544 Mbps High Capacity Channel Termination	CLR	30.00	88.00(4)

- (2) The key activated control channel is rated as a metallic channel termination (use USOC T6EME in lieu of T6ECS) and channel mileage, if applicable (use USOC 1L5MX in lieu of 1L5XX).
- (3) An additional Channel Termination Charge will apply whenever a spare channel is configured as a leg to the customer's premises. Additional channel mileage charges will also apply when the transfer arrangement is not located in the customer premises serving wire center.
- (4) This charge applies to installing clear channel capability coincident with the initial installation of the 1.544 Mbps service. Installation of this option to existing 1.544 Mbps service will be charged \$135.00 nonrecurring charge.
- (5) Effective June 30, 2021, Metallic Service will no longer be available for purchase by new or existing customers. In addition, requests to move, add, change, or renew existing service arrangements will not be accepted. Following the expiration of a customer's existing term agreement, service will be provided on a month-to-month basis at the applicable Monthly rates until the service is discontinued. The Company currently plans to discontinue this service on or after June 30, 2024.

(AT)
|
(AT)

**P.S.C. Mo. - No. 36
ACCESS SERVICES TARIFF**

Southwestern Bell Telephone
Company d/b/a AT&T Missouri

Section 7
2nd Revised Sheet 106
Replacing 1st Revised Sheet 106

ACCESS SERVICES

7. SPECIAL ACCESS SERVICE-(Continued)

7.4 Rates and Charges-(Continued)

7.4.12 Administrative Charges

1. Access Order Charges		<u>Nonrecurring Charges</u> (See Section 5)	
2. Service Arrangement Charge	<u>USOC</u>	<u>Nonrecurring Charges</u> <u>1st Ckt</u> <u>Addl. Ckt</u>	
- Per circuit(1) on the same Access Order for one or and combination of the following changes:			
- Access Carrier Name Abbreviation (ACNA). . . .		\$10.00	\$6.00
- Billing Account Number (BAN).		11.00	6.00
- Customer Circuit ID (CKR).		9.00	5.00

7.4.13 Rollover

	<u>USOC</u>	<u>Nonrecurring Charges</u> <u>1st Ckt</u> <u>Addl. Ckt</u>		
- Analog(2)/MegaLink Data(2) to 1.544 Mbps High Capacity - per service rolled over	NRBRA	\$110.00	\$80.00	(CP)
- 1.544 Mbps High Capacity to 1.544 Mbps High Capacity - per service rolled over	NRBRH	\$115.00	\$85.00	
- 1.544 Mbps High Capacity to MegaLink Custom - per service rolled over	NRBR1	\$115.00	\$85.00	

(1) Each leg of a multipoint service will be treated as a separate circuit and charges applied as described in Paragraph 7.3.1.

(2) Effective June 30, 2021, this Service will no longer be available for purchase by new or existing customers. In addition, requests to move, add, change, or renew existing service arrangements will not be accepted. Following the expiration of a customer's existing term agreement, service will be provided on a month-to-month basis at the applicable Monthly rates until the service is discontinued. The Company currently plans to discontinue this service on or after June 30, 2024. (AT)
|
(AT)