

BELLSOUTH
TELECOMMUNICATIONS, INC.
KENTUCKY
ISSUED: April 1, 1993
BY: M. H. Greene, President - KY
Louisville, Kentucky

ACCESS SERVICES TARIFF

PSC KY. TARIFF 2E
Second Revised Page 1
Cancels First Revised Page 1
EFFECTIVE: May 1, 1993

E2. GENERAL REGULATIONS

CONTENTS

E2.1	Undertaking Of The Company	1
E2.1.1	Scope	1
E2.1.2	Limitations	1
E2.1.3	Liability	1
E2.1.4	Provision Of Services	3
E2.1.5	Installation And Termination Of Service	3
E2.1.6	Maintenance Of Services	3
E2.1.7	Changes And Substitutions	3
E2.1.8	Refusal And Discontinuance Of Service	4
E2.1.9	Limitation Of Use Of Metallic Facilities	4
E2.1.10	Notification Of Service-Affecting Activities	4
E2.1.11	Coordination With Respect To Network Contingencies	4
E2.1.12	Provision And Ownership Of Telephone Numbers	4.1
E2.2	Use	5
E2.2.1	Interference Or Impairment	5
E2.2.2	Unlawful Use	5
E2.3	Obligations Of The Customer	5
E2.3.1	Damages	5
E2.3.2	Ownership Of Facilities And Theft	5
E2.3.3	Equipment Space And Power	5
E2.3.4	Reserved For Future Use	5
E2.3.5	Reserved For Future Use	5
E2.3.6	Availability For Testing	5
E2.3.7	Balance	6
E2.3.8	Design Of Customer Services	6
E2.3.9	References To The Company	6
E2.3.10	Reserved For Future Use	6
E2.3.11	Claims And Demands For Damages	6
E2.3.12	Reserved For Future Use	6

(M)

Material previously appearing on this page now appears on page(s) 1.1 of this section

BELLSOUTH
 TELECOMMUNICATIONS
 KENTUCKY
 ISSUED: January 4, 2012
 BY: Mary Pat Regan, President - KY
 Louisville, Kentucky

ACCESS SERVICES TARIFF

PSC KY. TARIFF 2E
 Second Revised Page 1.1
 Cancels First Revised Page 1.1
 EFFECTIVE: January 19, 2012

E2. GENERAL REGULATIONS

CONTENTS

E2.3	Obligations Of The Customer (Cont'd)	5	
E2.3.13	Coordination With Respect To Network Contingencies	6	
E2.3.14	Jurisdictional Report Requirements	7	
E2.3.15	Determination Of Intrastate Charges For Mixed Interstate and Intrastate Access Service	9	
E2.3.16	Sectionalization - Trouble Reporting	9	
E2.3.17	Reserved For Future Use	9	
E2.3.18	Reserved For Future Use	9	
E2.3.19	800 Number Reporting	9	
E2.3.20	Identification and Rating of VoIP-PSTN Traffic	9	(T)
E2.3.21	Utilization of Alternative Access Providers	9.4	(T)

BELLSOUTH
TELECOMMUNICATIONS
KENTUCKY
ISSUED: June 30, 2020
BY: Hood Harris, President
Louisville, Kentucky

ACCESS SERVICES TARIFF

PSC KY. TARIFF 2E
Tenth Revised Page 2
Cancels Ninth Revised Page 2
EFFECTIVE: July 15, 2020

E2. GENERAL REGULATIONS

CONTENTS

E2.4	Payment Arrangements And Credit Allowances	9.1	
E2.4.1	Payment Of Rates, Charges And Deposits	9.1	
E2.4.2	Minimum Periods	11.1	
E2.4.3	Cancellation Of An Order For Service	12	
E2.4.4	Credit Allowance For Service Interruptions	12	
E2.4.5	Reserved For Future Use	14	
E2.4.6	Re-establishment Of Service Following Fire, Flood Or Other Occurrence	14	
E2.4.7	Title Or Ownership Rights	15	
E2.4.8	Billing Of Access Services Provided by Multiple Companies	15	
E2.4.9	Optional Payment Plan	18	
E2.4.10	Service Installation Guarantee	18.2.1	
E2.4.11	Provision For Certain State And Local Taxes And Fees	18.2.1	
E2.5	Connections	18.3	
E2.5.1	General	18.3	
E2.6	Definitions	18.3	
E2.7	Special Promotions	28	
E2.7.1	Regulations	28	
E2.7.2	Reserved For Future Use	28	
E2.8	Reserved For Future Use	28	
E2.9	Reserved For Future Use	28	
E2.10	Reserved For Future Use	28	
E2.11	Trademarks and Servicemarks Protection	28	
E2.11.1	Use of Trademarks and Servicemarks	28	
E2.12	TDM to IP Transition	29	(N)
E2.12.1	General TDM to IP Transition Provisions	29	(N)

BELLSOUTH
 TELECOMMUNICATIONS
 KENTUCKY
 ISSUED: June 17, 2013
 BY: Tony Taylor, Executive Director
 Louisville, Kentucky

ACCESS SERVICES TARIFF

PSC KY. TARIFF 2E
 Fifth Revised Page 1
 Cancels Fourth Revised Page 1
 EFFECTIVE: July 2, 2013

E2. GENERAL REGULATIONS**E2.1 Undertaking Of The Company****E2.1.1 Scope**

- A. The Company does not undertake to transmit messages under this Tariff.
- B. The Company shall be responsible only for the installation, operation and maintenance of the services it provides.
- C. The Company will, for maintenance purposes, test its services only to the extent necessary to detect and/or clear troubles.
- D. Services are provided 24 hours daily, seven days per week, except as set forth in other applicable sections of this Tariff.
- E. The Company does not warrant that its facilities and services meet standards other than those set forth in this Tariff.

E2.1.2 Limitations

- A. The customer may not assign or transfer the use of services provided under this Tariff, except as provided herein. Where there is no interruption of use or relocation of the services, such assignment or transfer may be made to:
 1. Another customer, whether an individual, partnership, association or corporation, provided the assignee or transferee assumes all outstanding indebtedness for such services, and the unexpired portion of the minimum period and the termination liability applicable to such services, if any; or
 2. A court appointed receiver, trustee or other person acting pursuant to law in bankruptcy, receivership, reorganization, insolvency, liquidation or other similar proceedings, provided the assignee or transferee assumes the unexpired portion of the minimum period and the termination liability applicable to such services, if any.

In all cases of assignment or transfer, the written acknowledgement of the Company is required prior to such assignment or transfer. Such acknowledgement shall be made within 15 days from the receipt of notification. All regulations and conditions contained in this Tariff shall apply to such assignee or transferee.

The assignment or transfer of services does not relieve or discharge the assignor or transferor from remaining jointly or severally liable with the assignee or transferee for any obligations existing at the time of the assignment or transfer.

- B. The use and restoration of services shall be in accordance with Part 64, Subpart D, Appendix A, of the Federal Communications Commission's Rules and Regulations, which specifies the priority system for such activities.
- C. Subject to compliance with the rules mentioned in B. preceding, the services offered herein will be provided to customers on a first-come, first-served basis.
- D. Terms and conditions for central office interconnection of collocator-provided Company leased equipment are set forth in Tariff F.C.C. No. 1, Section 20. Virtual Collocation Cross-Connect rates and charges are provided in Section 6 of Tariff FCC No. 1 and Section E7. of this intrastate Tariff for each service allowed under collocation guidelines.

(D)
 (C)

E2.1.3 Liability

- A. The Company's liability, if any, for its willful misconduct is not limited by this Tariff. With respect to any other claim or suit, by a customer, or by any others, for damages associated with the installation, provision, preemption, termination, maintenance, repair or restoration of service, and subject to the provisions of B. through H. following, the Company's liability, except as set forth in E2.1.3 following, if any, shall not exceed an amount equal to the proportionate charge for the service for the period during which the service was affected. This liability for damages shall be in addition to any amounts that may otherwise be due the customer under this Tariff as a Credit Allowance for a Service Interruption.
- B. The Company shall not be liable for any act or omission of any other carrier or customer providing a portion of a service, nor shall the Company for its own act or omission hold liable any other carrier or customer providing a portion of a service.

BELLSOUTH
TELECOMMUNICATIONS, INC.
KENTUCKY
ISSUED: March 9, 1998
BY: E.C. Roberts, Jr., President - KY
Louisville, Kentucky

ACCESS SERVICES TARIFF

PSC KY. TARIFF 2E
Second Revised Page 2
Cancels First Revised Page 2
EFFECTIVE: April 9, 1998

E2. GENERAL REGULATIONS**E2.1 Undertaking Of The Company (Cont'd)****E2.1.3 Liability (Cont'd)**

- C.** The Company is not liable for damages to the customer premises resulting from the furnishing of a service, including the installation and removal of equipment and associated wiring, unless the damage is caused by the Company's negligence. (T)
- D.** The Company shall be indemnified, defended and held harmless by the end user against any claim, loss or damage arising from the end user's use of services offered under this Tariff, involving: (T)
1. Claims for libel, slander, invasion of privacy, or infringement of copyright arising from the end user's own communications;
 2. Claims for patent infringement arising from the end user's acts combining or using the service furnished by the Company in connection with facilities or equipment furnished by the end user or IC or;
 3. All other claims arising out of any act or omission of the end user in the course of using services provided pursuant to this Tariff.
- E.** The Company shall be indemnified, defended and held harmless by the IC against any claim, loss or damage arising from the IC's use of services offered under this Tariff, involving: (T)
1. Claims for libel, slander, invasion of privacy, or infringement of copyright arising from the IC's own communications;
 2. Claims for patent infringement arising from the IC's acts combining or using the service furnished by the Company in connection with facilities or equipment furnished by the end user or IC or;
 3. All other claims arising out of an act or omission of the IC in the course of using services provided pursuant to this Tariff.
- F.** The Company does not guarantee or make any warranty with respect to its services when used in an explosive atmosphere. The Company shall be indemnified, defended and held harmless by the customer from any and all claims by any person relating to such customer's use of services so provided. (T)
- G.** No license under patents (other than the limited license to use) is granted by the Company or shall be implied or arise by estoppel, with respect to any service offered under this Tariff. The Company will defend the customer against claims of patent infringement arising solely from the use by the customer of services offered under this Tariff and will indemnify such customer for any damages awarded based solely on such claims. (T)
- H.** The Company's failure to provide or maintain services under this Tariff shall be excused by labor difficulties, governmental orders, civil commotions, criminal actions taken against the Company, acts of God and other circumstances beyond the Company's reasonable control, subject to the Credit Allowance for Service Interruptions as set forth in E2.4.4 following. (T)
- I.** Should any federal, state or local jurisdiction determine that sales, use, gross receipts or any other taxes (including interest, penalties and surcharges thereon) are due by the Company as a result of the Company's purchase of accounts receivable, the Company will advise the customer and the customer shall be liable for any such tax, interest, penalties and surcharge and the customer shall immediately reimburse the Company the amount of such tax, interest, penalties and surcharge paid by the Company. If the customer disagrees with the Company's determination that any taxes are due by the Company or disagrees with an assessment of any tax, penalty, surcharge and interest due by the Company as a result of the Company's purchase of accounts receivable, the customer shall, at its option and expense (including immediate payment of any such assessment), have the right to seek a ruling as to the inapplicability of any such tax or to protest any assessment and participate in any legal challenge to such assessment, but shall be liable for any tax, penalty, surcharge and interest ultimately determined to be due. (T)
- J.** Unauthorized Computer Intrusion (N)
- The Company's liability, if any, for its willful misconduct is not limited by this section of this Tariff. With respect to any other claim or suit by a subscriber, common carrier, reseller, or any other party for damages caused by, or associated with, any unauthorized computer intrusion, including but not limited to the input of damaging information such as a virus, time bomb, any unauthorized access, interference, alteration, destruction, theft of, or tampering with, a Company computer, switch, data, database, software, information, network or other similar system, the Company's liability, if any, shall not exceed an amount equal to the proportionate charge by the Company for the service for the period during which the service provided by the Company was affected or so utilized. (N)
- Each subscriber of the Company shall be responsible for providing appropriate security measures to protect the subscriber's computer, data, or telecommunications network. (N)

BELLSOUTH
TELECOMMUNICATIONS
KENTUCKY
ISSUED: July 18, 2019
BY: Hood Harris, President
Louisville, Kentucky

ACCESS SERVICES TARIFF

PSC KY. TARIFF 2E
Sixth Revised Page 3
Cancels Fifth Revised Page 3
EFFECTIVE: August 2, 2019

E2. GENERAL REGULATIONS

E2.1 Undertaking Of The Company (Cont'd)

E2.1.3 Liability (Cont'd)

K. Transmission of Data

The Company shall not be held liable for any damage, harm or loss of data caused by the subscriber using the Company's voice-grade telephone access lines and/or facilities for the transmission of data. Voice-grade lines are primarily conditioned to handle data speeds up to 9.6 kilobits per second (kbps). The Company's liability shall be limited to errors or damages to the transmission of voice messages over these facilities, and the liability shall be limited to an amount equal to the proportionate amount of the Company's billing for the period of service during which the errors or damages occur.

The Company's liability for damages or errors caused during the transmission of data over any of the Company's data facilities shall be limited to an amount equal to the proportionate charge for the service for the period during which the service was affected.

L. Errors or Damages Caused by System Date Limitations

The Company's liability for errors or damages resulting from the inability of the Company's systems to process dates, such as the Year 2000, shall be limited to an amount equal to the proportionate amount of the Company's billing for the period of service during which the errors or damages occur.

M. Unauthorized Devices

The Company shall not be held liable or responsible for any damage or harm that may occur as the result of unauthorized devices or the failure of the Company to detect unauthorized devices on the subscriber's line.

E2.1.4 Provision Of Services

The Company, to the extent that such services are or can be made available with reasonable effort, and after provision has been made for the Company's telephone exchange services, will provide to the customer upon reasonable notice services offered in other applicable sections of this Tariff at rates and charges specified therein.

The Company may discontinue certain Company services in geographic areas for which the Company has no customers subscribing to those services. (N)

E2.1.5 Installation And Termination Of Services

The Access Services provided under this Tariff will (A) include any entrance cable or drop wiring and wire or intrabuilding cable to that point where provision is made for termination of the Company's outside distribution network facilities at a suitable location inside a customer-designated premises and (B) will be installed by the Company to such Point of Termination. Each Access Service has only one Point of Termination per customer premises. Any additional terminations beyond such Point of Termination is the sole responsibility of the customer. The Point of Termination is an inherent part of BellSouth SWA and Special Access (a.k.a. BellSouth SPA) services, therefore, the preceding does not preclude the customer's ability to have each Point of Termination moved as set forth in E7.4.5 following.

E2.1.6 Maintenance Of Services

The services provided under this Tariff shall be maintained by the Company. The customer or others may not rearrange, move, disconnect, remove or attempt to repair any facilities provided by the Company other than by connection or disconnection to any interface means used, except with the written consent of the Company.

E2.1.7 Changes And Substitutions

Except as provided for equipment and systems subject to F.C.C. Part 68 Regulations at 47 C.F.R. Section 68.110(b), the Company may, where such action is reasonably required in the operation of its business:

- A. Substitute, change or rearrange any facilities used in providing service under this Tariff, including but not limited to:
 1. Substitution of different metallic facilities,
 2. Substitution of carrier or derived facilities for metallic facilities used to provide other than metallic facilities, and
 3. Substitution of metallic facilities for carrier or derived facilities used to provide other than metallic facilities,

Page reformatted pursuant to 807 KAR 5:011—Tariffs, Section 3 (4).

BELLSOUTH
TELECOMMUNICATIONS
KENTUCKY
ISSUED: June 17, 2013
BY: Tony Taylor, Executive Director
Louisville, Kentucky

ACCESS SERVICES TARIFF

PSC KY. TARIFF 2E
Fourth Revised Page 4
Cancels Third Revised Page 4
EFFECTIVE: July 2, 2013

E2. GENERAL REGULATIONS**E2.1 Undertaking Of The Company (Cont'd)****E2.1.7 Changes And Substitutions (Cont'd)**

- B. Change minimum protection criteria,
- C. Change operating or maintenance characteristics of facilities, or
- D. Change operations or procedures of the Company.

In case of any such substitution, change or rearrangement, the transmission parameters will be within the range as set forth in Section 6 of Tariff FCC No. 1 and Section E7. of this intrastate Tariff. The Company shall not be responsible if any such substitution, change or rearrangement renders any customer furnished services obsolete or requires modification or alteration thereof or otherwise affects their use or performance. If such substitution, change or rearrangement materially affects the operating characteristics of the facility, the Company will provide reasonable notification to the customer in writing. Reasonable time will be allowed for any redesign and implementation required by the change in operating characteristics. The Company will work cooperatively with the customer to determine reasonable notification requirements.

E2.1.8 Refusal And Discontinuance Of Service

- A. Unless the provisions of E2.2.1.B. or E2.5. following apply, if a customer fails to comply with E2.1.6. preceding or E2.2.2., E2.3.1., **E2.3.6.**, **E2.3.7.**, **E2.3.14.** or E2.4. following, including any payments to be made by it on the dates and times herein specified, the Company may, on thirty (30) days written notice by Certified U.S. Mail **or Overnight Delivery** to the person designated by that customer to receive such notices of noncompliance, refuse additional applications for service and/or refuse to complete any pending orders for service by the noncomplying customer at any time thereafter. If the Company does not refuse additional applications for service on the date specified in the thirty (30) days notice, and the customer's noncompliance continues, nothing contained herein shall preclude the Company's right to refuse additional applications for service to the noncomplying customer without further notice.
- B. Unless the provisions of E2.2.1.B. or E2.5. following apply, if the customer fails to comply with E2.1.6. preceding or E2.2.2., E2.3.1., **E2.3.6.**, **E2.3.7.**, **E2.3.14.** or E2.4. following, including any payments to be made by it on the dates and times herein specified, the Company may, on thirty (30) days written notice by Certified U. S. Mail **or Overnight Delivery** to the person designated by that customer to receive such notices of noncompliance, discontinue the provision of the services to the noncomplying customer at any time thereafter. In the case of such discontinuance, all applicable charges, including termination charges, shall become due. If the Company does not discontinue the provision of the services involved on the date specified in the thirty (30) days notice, and the customer's noncompliance continues, nothing contained herein shall preclude the Company's right to discontinue the provision of the services to the noncomplying customer without further notice.
- C. In addition to and not in limitation of the provisions of E2.1.8.A. and E2.1.8.B. preceding, unless the provisions of E2.2.1.B. or E2.5. following apply, if a customer fails to comply with E2.4.1.A. or with E2.4.1.B.3. following, including any payment to be made by it on the dates and times herein specified, the Company may take actions specified in E2.1.8.A. and E2.1.8.B. on fifteen (15) calendar days written notice, such notice period to start the day after the notice is rendered by Certified Mail or Overnight Delivery, if the customer has not complied with respect to amounts due in a subject bill and either:
 1. The Company has within seven (7) business days of the subject bill date:
 - a. Mailed via the United States Postal Service (USPS) to the customer the subject bill in paper or CDROM form, or
 - b. Overnight service delivered to the customer the subject bill in Magnetic Tape form, or
 - c. Electronically Transmitted to the customer the subject bill.

The Company will maintain records sufficient to validate the date upon which a subject bill was rendered to the customer.

Page reformatted pursuant to 807 KAR 5:011—Tariffs, Section 3 (4).

BELLSOUTH
TELECOMMUNICATIONS
KENTUCKY
ISSUED: June 17, 2013
BY: Tony Taylor, Executive Director
Louisville, Kentucky

ACCESS SERVICES TARIFF

PSC KY. TARIFF 2E
First Revised Page 4.1
Cancels Original Page 4.1
EFFECTIVE: July 2, 2013

E2. GENERAL REGULATIONS

E2.1 Undertaking Of The Company (Cont'd)

E2.1.8 Refusal And Discontinuance Of Service (Cont'd)

C. (Cont'd)

2. The Company has rendered the subject bill, using one of the media described in 1. above, to the customer more that thirty (30) calendar days before notice under this section has been rendered.

In all other cases, the Company will give thirty (30) calendar days written notice pursuant to E2.1.8.A. of E2.1.8.B.. Action will not be taken with regard to the subject bill if the customer cures the noncompliance prior to the expiration of the fifteen (15) or thirty (30) calendar day notice period, as applicable.

E2.1.9 Limitation Of Use Of Metallic Facilities

Signals applied to the metallic facility shall conform to the limitations set forth in Technical Reference Publication AS No. 1. In the case of application of dc telegraph signaling systems, the customer shall be responsible, at its expense, for the provision of current limiting devices to protect the Company facilities from excessive current due to abnormal conditions and for the provision of noise mitigation networks when required to reduce excessive noise.

E2.1.10 Notification Of Service-Affecting Activities

The Company will provide the customer reasonable notification of service-affecting activities that may occur in normal operation of its business. Such activities may include, but are not limited to, equipment or facilities additions, removals or rearrangements, routine preventive maintenance and major switching machine change-out. Generally, such activities are not individual customer service specific, they affect many customer services. No specific advance notification period is applicable to all service activities. The Company will work cooperatively with the customer to determine the notification requirements.

E2.1.11 Coordination With Respect To Network Contingencies

The Company intends to work cooperatively with the customer to develop network contingency plans in order to maintain maximum network capability following natural or man-made disasters that affect telecommunications services.

This includes developing plans for originating or terminating traffic associated with mass calling events directed to end users served from specific end offices. Where it is determined that such non-random calling generates problems on the Telephone Company's Common Transport network, the Telephone Company will work cooperatively with the customer to relieve the traffic congestion. Remedial measures may include isolation of the customer from the Telephone Company network in the impacted area for the duration of the problem or until the customer notifies the Telephone Company that the problem has been resolved.

E2.1.12 Provision And Ownership Of Telephone Numbers

The Company reserves the reasonable right to assign, designate or change telephone numbers, any other call number designations associated with Access Service, or the Company serving central office prefixes associated with such numbers, when necessary in the conduct of its business. Should it become necessary to *make a* change in such number(s), the Company will furnish to the customer 6 months notice, by Certified U.S. Mail, of the effective date and an explanation of the reason(s) for such change(s).

Page reformatted pursuant to 807 KAR 5:011—Tariffs, Section 3 (4).

(M)

(M)

BELLSOUTH
TELECOMMUNICATIONS, INC.
KENTUCKY

ISSUED: February 16, 1990
BY: M. H. Greene, President - KY
Louisville, Kentucky

ACCESS SERVICES TARIFF

PSC KY. TARIFF 2E
First Revised Page 5
Cancels Original Page 5
EFFECTIVE: September 17, 1990

E2. GENERAL REGULATIONS

E2.2 Use

E2.2.1 Interference Or Impairment

- A. The characteristics and methods of operation of any circuits, facilities or equipment provided by other than the Company and associated with the facilities utilized to provide services under this Tariff shall not interfere with or impair service over any facilities of the Company, its affiliated companies, or its connecting and concurring carriers involved in its services, cause damage to their plant, impair the privacy of any communications carried over their facilities or create hazards to the employees of any of them or the public.
- B. Except as provided for equipment or systems subject to the F.C.C. Part 68 Rules in 47 C.F.R. Section 68.108, if such characteristics or methods of operation are not in accordance with A. preceding, the Company will, where practicable, notify the customer that temporary discontinuance of the use of a service may be required; however, where prior notice is not practicable, nothing contained herein shall be deemed to preclude the Company's right to temporarily discontinue forthwith the use of a service if such action is reasonable under the circumstances. In case of such temporary discontinuance, the customer will be promptly notified and afforded the opportunity to correct the condition which gave rise to the temporary discontinuance. During such period of temporary discontinuance, credit allowance for service interruptions as set forth in E2.4.4.A. and B. following is not applicable. (T)

E2.2.2 Unlawful Use

The service provided under this Tariff shall not be used for an unlawful purpose.

E2.3 Obligations Of The Customer

E2.3.1 Damages

The customer shall reimburse the Company for damages to Company facilities utilized to provide services under this Tariff caused by the negligence or willful act of the customer or resulting from the customer's improper use of the Company facilities, or due to malfunction of any facilities or equipment provided by other than the Company. Nothing in the foregoing provision shall be interpreted to hold one customer liable for another customer's actions. The Company will, upon reimbursement for damages, cooperate with the customer in prosecuting a claim against the person causing such damage and the customer shall be subrogated to the right of recovery by the Company for the damages to the extent of such payment.

E2.3.2 Ownership Of Facilities And Theft

Facilities utilized by the Company to provide service under the provisions of this Tariff shall remain the property of the Company. Such facilities shall be returned to the Company by the customer, whenever requested, within a reasonable period following the request in as good condition as reasonable wear will permit.

E2.3.3 Equipment Space And Power

The customer shall furnish or arrange to have furnished to the Company, at no charge, equipment space and electrical power required by the Company to provide services under this Tariff at the points of termination of such services. The selection of ac or dc power shall be mutually agreed to by the customer and the Company. The customer shall also make necessary arrangements in order that the Company will have access to such spaces at reasonable times for installing, testing, repairing or removing Company services. (T)

E2.3.4 Reserved For Future Use (T)

E2.3.5 Reserved For Future Use (T)

E2.3.6 Availability For Testing (T)

The services provided under this Tariff shall be available to the Company at times mutually agreed upon in order to permit the Company to make tests and adjustments appropriate for maintaining the services in satisfactory operating condition. Such tests and adjustments shall be completed within a reasonable time. No credit will be allowed for any interruptions involved during such tests and adjustments.

BELLSOUTH
TELECOMMUNICATIONS, INC.
KENTUCKY
ISSUED: February 16, 1990
BY: M. H. Greene, President - KY
Louisville, Kentucky

ACCESS SERVICES TARIFF

PSC KY. TARIFF 2E
First Revised Page 6
Cancels Original Page 6
EFFECTIVE: September 17, 1990

E2. GENERAL REGULATIONS

E2.3 Obligations Of The Customer (Cont'd)

E2.3.7 Balance (T)

All signals for transmission over the services provided under this Tariff shall be delivered by the customer balanced to ground except for ground start, duplex (DX) and McCulloh-Loop (Alarm System) type signaling and dc telegraph transmission at speeds of 75 baud or less.

E2.3.8 Design Of Customer Services (T)

Subject to the provisions of E2.1.7 preceding, the customer shall be solely responsible, at its own expense, for the overall design of its services and for any redesigning or rearrangement of its services which may be required because of changes in facilities, operations or procedures of the Company, minimum protection criteria or operating or maintenance characteristics of the facilities.

E2.3.9 References To The Company (T)

The customer may advise End Users that certain services are provided by the Company in connection with the service the customer furnishes to its End Users; however, the customer shall not represent that the Company jointly participates in the customer's services.

E2.3.10 Reserved For Future Use (T)

E2.3.11 Claims And Demands For Damages (T)

- A. With respect to claims of patent infringement made by third persons, the customer shall defend, indemnify, protect and save harmless the Company from and against all claims arising out of the combining with, or use in connection with, the services provided under this Tariff, any circuit, apparatus, system or method provided by the customer.
- B. The customer shall defend, indemnify and save harmless the Company from and against any suits, claims, losses or *demands*, including punitive damages, attorney's fees and court costs by third persons arising out of the construction, installation, operation, maintenance, or removal of the customer's circuits, facilities, or equipment connected to the Company's services provided under this Tariff including, without limitation, Workmen's Compensation claims, actions for infringement of copyright and/or unauthorized use of program material, libel and slander actions based on the content of communications transmitted over the customer's circuits, facilities or equipment, and proceedings to recover taxes, fines, or penalties for failure of the customer to obtain or maintain in effect any necessary certificates, permits, licenses, or other authority to acquire or operate the services provided under this Tariff; provided, however, the foregoing indemnification shall not apply to suits, claims, and demands to recover damages for damage to property, death, or personal injury unless such suits, claims or demands are based on the tortious conduct of the customer, its officers, agents or employees.
- C. The customer shall defend, indemnify and save harmless the Company from and against any suits, claims, losses or damages, including punitive damages, attorney fees and court costs by the customer or third parties arising out of any act or omission of the customer in the course of using services provided under this Tariff.

E2.3.12 Reserved For Future Use (T)

E2.3.13 Coordination With Respect To Network Contingencies (T)

The customer shall, in cooperation with the Company, coordinate in planning the actions to be taken to maintain maximum network capability following natural or man-made disasters which affect telecommunications services.

BELLSOUTH
 TELECOMMUNICATIONS
 KENTUCKY
 ISSUED: June 17, 2013
 BY: Tony Taylor, Executive Director
 Louisville, Kentucky

ACCESS SERVICES TARIFF

PSC KY. TARIFF 2E
 Eighteenth Revised Page 7
 Cancels Seventeenth Revised Page 7
 EFFECTIVE: July 2, 2013

E2. GENERAL REGULATIONS

E2.3 Obligations Of The Customer (Cont'd)

E2.3.14 Jurisdictional Report Requirements¹

A. Jurisdictional Reports

1. Percent Interstate Usage (PIU)

- a. The interstate usage is to be developed as though every call that originates from a calling location (as designated by the calling station number) within the same as that in which the called station (as designated by the called station number) is situated is an intrastate communication and every call for which the point of origination (as designated by the calling station number) is in a state other than that where the called station (as designated by the called station number) is situated is an interstate communication. The manner in which a call is routed through the telecommunications network does not affect the jurisdiction of a call, i.e., a call between two points within the same state is an intrastate communication even if the call is routed through another state.
- b. When the Company receives sufficient call detail to permit it to determine the jurisdiction of originating and terminating access minutes of use, the Company will bill according to these actual minutes of use and will not use customer reported Percent Interstate Usage (PIU) factors.

The Company developed percent interstate usage for access minutes of use will be determined at a statewide level. The interstate percentage will be developed on a monthly basis by end office, when the access minutes are measured by dividing the measured interstate originating or terminating access minutes (the access minutes where the calling number is in one state and the called number is in another state) by the total originating or terminating access minutes.

The Company will bill according to actual measured minutes of use or messages for all services listed in c. and 5. following, with the exception of those listed following:

- BellSouth SWA Local Channel
- BellSouth SWA Dedicated Interoffice Channel
- BellSouth Inward Operator Service
- BellSouth Billing Name and Address
- Channelization Equipment
- DNALs² associated with BellSouth SWA LSBSA

Where the Company receives insufficient call detail to identify the calling station to determine the jurisdiction, the Company will charge the applicable rates for terminating BellSouth SWA as set forth in this Tariff. There may be a percentage of usage where it is not possible to know, and therefore to send to BellSouth, the needed originating information. Accordingly, BellSouth will charge the terminating BellSouth SWA rate for only those minutes lacking originating information from all SWA customers, currently **19.22%** (the "floor"). For example, if 30% of a customer's minutes sent to BellSouth do not contain sufficient originating information to allow BellSouth to determine the originating location, then BellSouth would apply the provisions of this tariff to those minutes exceeding the "floor", or **10.78%** in this example.

Note 1: Except where indicated herein, references to BellSouth SWA FGs will also include the applicable BellSouth SWA Basic Serving Arrangement as detailed in the matrix in Section 6.1.3 of Tariff FCC No. 1 (e.g., the term BellSouth SWA FGA represents both BellSouth SWA FGA and BellSouth SWA LSBSA). (C)

Note 2: Where BellSouth SWA LSBSA is provisioned with a DNAL, the DNAL rates should be apportioned between interstate and intrastate using the same PIU factor as applied to the associated BellSouth SWA LSBSA. (C)

Page reformatted pursuant to 807 KAR 5:011—Tariffs, Section 3 (4).

BELLSOUTH
TELECOMMUNICATIONS
KENTUCKY
ISSUED: June 17, 2013
BY: Tony Taylor, Executive Director
Louisville, Kentucky

ACCESS SERVICES TARIFF

PSC KY. TARIFF 2E
Ninth Revised Page 7.1
Cancels Eighth Revised Page 7.1
EFFECTIVE: July 2, 2013

E2. GENERAL REGULATIONS

E2.3 Obligations Of The Customer (Cont'd)

E2.3.14 Jurisdictional Report Requirements¹ (Cont'd)

A. Jurisdictional Reports (Cont'd)

1. Percent Interstate Usage (PIU) (Cont'd)

b.(Cont'd)

BellSouth will recalculate the overall SWA customer average “floor” quarterly. In addition, subsequent reviews or audits of specific customer usage may result in a new “floor” for that customer.

In the event that BellSouth applies the intrastate terminating access rate to calls without sufficient originating information as provided in this tariff, BellSouth’s access customers will have the opportunity to request backup documentation of BellSouth’s basis for such application, and further request that BellSouth change the application of the intrastate access rate upon a showing of why the intrastate rate should not be applied.

For the purpose of this tariff, where the customer is a *Third-Party Provider* (“*Third-Party Provider*”) of CCS7 services to its customers (“Third Party Customers”), the *Third-Party Provider* will develop its projected PIU factor based upon a weighted average of the PIUs of its Third Party Customers’ end user traffic in accordance with the procedures described below. *A Third-Party Provider may elect to have the Company determine the weighted PIU and in so doing the Third-Party Provider shall name and identify their Third Party Customers. In the event a Third Party Provider does not provide a projected PIU or does not elect to have the Company determine the PIU, a 50 percent PIU will be utilized for that Third-Party Provider, until such time as the Company obtains sufficient data to develop the PIU as specified in c. following.* In the event a Third Party Customer does not provide a projected PIU, a 50 percent PIU will be utilized for that Third Party Customer.

The customer will provide in its initial order the projected Percent Interstate Usage (PIU) at a statewide level on a local exchange company specific basis. When the customer computes the PIU it will subtract the developed PIU from 100 and the difference is the percent intrastate usage. The sum of the interstate and intrastate percentages will equal 100 percent. A PIU of less than 100 percent is not allowed where the service is not available as an intrastate access service. The projected PIU may include up to two decimals.

The Company will designate the number obtained by subtracting the projected interstate furnished by the customer from 100 (100 – customer percentage – intrastate percentage) as the projected intrastate percentage of use.

Note 1: Except where indicated herein, references to BellSouth SWA FGs will also include the applicable BellSouth SWA Basic Serving Arrangement as detailed in the matrix in Section 6.1.3 of Tariff FCC No. 1 (e.g., the term BellSouth SWA FGA represents both BellSouth SWA FGA and BellSouth SWA LSBSA). (C)
(C)

Page reformatted pursuant to 807 KAR 5:011—Tariffs, Section 3 (4).

BELLSOUTH
TELECOMMUNICATIONS
KENTUCKY
ISSUED: August 5, 2016
BY: Hood Harris, President
Louisville, Kentucky

ACCESS SERVICES TARIFF

PSC KY. TARIFF 2E
Seventh Revised Page 7.1.1
Cancels Sixth Revised Page 7.1.1
EFFECTIVE: August 20, 2016

E2. GENERAL REGULATIONS**E2.3 Obligations of The Customer (Cont'd)****E2.3.14 Jurisdictional Report Requirements (Cont'd)****A. Jurisdictional Reports (Cont'd)****1. Percent Interstate Usage (PIU) (Cont'd)**

c. When a customer initially orders service(s), as defined in the following, the customer will state in its order the Percent Interstate Usage (PIU) separately for each, as set forth in a. and b. preceding.

- BellSouth SWA FGA
- BellSouth SWA FGB
- BellSouth SWA FGD
- BellSouth SWA 500 Service
- 700 Service
- BellSouth SWA 8XX Toll Free Dialing Ten Digit Screening Service
- BellSouth SWA 900 Service
- BellSouth CCS7 Access Arrangement
- Switched Local Channel
- BellSouth SWA Dedicated Interoffice Channel
- Channelization Equipment
- DNALs¹ associated with BellSouth SWA LSBSA
- BellSouth Billing Name and Address

(D)

The Percent Interstate Usage (PIU) factors associated with BellSouth SWA FGA, BellSouth SWA FGB, BellSouth SWA FGD, BellSouth SWA 500, 700, BellSouth SWA 8XX Toll Free Dialing Ten Digit Screening service and BellSouth SWA 900, this PIU will also apply to all associated elements and services, e.g. Carrier Common Line, Local Switching, BellSouth SWA Common Interoffice Channel, Interconnection, Access Tandem Switching, Common Trunk Port Service and minute of use based multiplexer rate elements, where applicable.

Note 1: Where BellSouth SWA LSBSA is provisioned with a DNAL, the DNAL rates should be apportioned between interstate and intrastate using the same PIU factor as applied to the associated BellSouth SWA LSBSA.

Page reformatted pursuant to 807 KAR 5:011—Tariffs, Section 3 (4).

BELLSOUTH
TELECOMMUNICATIONS
KENTUCKY
ISSUED: June 17, 2013
BY: Tony Taylor, Executive Director
Louisville, Kentucky

ACCESS SERVICES TARIFF

PSC KY. TARIFF 2E
Sixth Revised Page 7.2
Cancels Fifth Revised Page 7.2
EFFECTIVE: July 2, 2013

E2. GENERAL REGULATIONS**E2.3 Obligations of the Customer (Cont'd)****E2.3.14 Jurisdictional Report Requirements (Cont'd)****A. Jurisdictional Reports (Cont'd)****1. Percent Interstate Usage (PIU) (Cont'd)**

The customer will provide a single factor as the projected Percent Interstate Usage (PIU) to apportion the usage between interstate and intrastate. This factor will be applied to the following categories:

- Switched Local Channel
- BellSouth SWA Dedicated Interoffice Channel
- Channelization Equipment

The PIU category, BellSouth SWA Local Channel, includes Dedicated End Office Trunk Port Service and Dedicated Tandem Trunk Port Service charges and other flat rated charges not specifically covered by other PIU categories.

The PIU factor provided for each of the foregoing facilities categories (Switched Local Channel, BellSouth SWA Dedicated Interoffice Channel and Channelization Equipment) will reflect the combination of all traffic types which traverse such facility category.

When Special Access (a.k.a. BellSouth SPA) service is provided on a BellSouth SWA facility, e.g., Special Access (a.k.a. BellSouth SPA) DS1 on a BellSouth SWA DS3, the facility will be apportioned between BellSouth SWA and Special Access (a.k.a. BellSouth SPA). The jurisdiction of the Special Access (a.k.a. BellSouth SPA) service shall reflect the composite of the jurisdiction of the lower capacity services, if any, of which it is comprised.

The customer shall compute the PIU using the following formula (rounded to a whole percentage).

$$\frac{\text{Total Interstate Originating Minutes}}{\text{Total Originating Minutes}} + \frac{\text{Total Interstate Terminating Minutes}}{\text{Total Terminating Minutes}}$$

Note 1: Except where indicated herein, references to BellSouth SWA FGs will also include the applicable BellSouth SWA Basic Serving Arrangement as detailed in the matrix in Section 6.1.3 of Tariff FCC No. 1 (e.g., the term BellSouth SWA FGA represents both BellSouth SWA FGA and BellSouth SWA LSBSA)

(M)

(C)

(C)

(M)

Page reformatted pursuant to 807 KAR 5:011—Tariffs, Section 3 (4).

BELLSOUTH
TELECOMMUNICATIONS
KENTUCKY
ISSUED: June 17, 2013
BY: Tony Taylor, Executive Director
Louisville, Kentucky

ACCESS SERVICES TARIFF

PSC KY. TARIFF 2E
Thirteenth Revised Page 8
Cancels Twelfth Revised Page 8
EFFECTIVE: July 2, 2013

E2. GENERAL REGULATIONS

E2.3 Obligations Of The Customer (Cont'd)

E2.3.14 Jurisdictional Report Requirements¹ (Cont'd)

A. Jurisdictional Reports (Cont'd)

2. For BellSouth Directory Assistance Access, the Company developed PIU for BellSouth SWA FGD terminating will apply.
3. *For BellSouth CCS7 Access Arrangement, the customer must state in its order the PIU anticipated as specified in c. preceding. The PIU reported will then be applied to the rates for Signaling Connections and Terminations to arrive at the amount the customer is billed for intrastate usage of these facilities each month. In addition, the PIU will be applied to the total messages and the resulting figure multiplied by the appropriate rate per message to determine the amount that the customer will be billed for intrastate usage. Subsequent PIU factors will be reported as required in (5) following.*
4. *Effective July 1, 2001, the customer will update the jurisdictional report associated with BellSouth CCS7 Access Arrangement, when both intrastate and interstate service is provided.*

Effective October 1, 2000, the customer will provide a single factor as the projected Percent Interstate Usage (PIU) to apportion the usage between interstate and intrastate. This PIU will apply to the following categories: Switched Local Channel, BellSouth SWA Dedicated Interoffice Channel and Channelization Equipment.

Effective July 1, 2000, the customer's projected Percent Interstate Usage (PIU) will be provided at a statewide level on a local exchange company specific basis.

Effective on the first of January, April, July and October of each year the customer will update the interstate and intrastate jurisdictional report. The customer will forward to the Company, to be received no later than 30 days after the first of each such month, a revised report for all services showing the interstate and intrastate percentage of use for the past three months ending the last day of December, March, June and September, respectively, for each service arranged for interstate use. The revised report will serve as the basis for the next three months billing, and will be effective on the bill date for that service. If the customer does not supply an updated quarterly report, the Company will assume the percentage interstate usage to be the same PIU as provided in the last quarterly report accepted by the Company. If an audit has been completed and an updated quarterly report has not been submitted subsequent to the audit, the Company will assume the PIU factors to be the most recent audited results. For those cases in which a quarterly report has never been received from the customer, the Company will assume the PIU factors to be the most recent audit results or to be the same as provided in the order for service if no audit has been performed.

5. When mixed interstate and intrastate Special Access (a.k.a. BellSouth SPA) service is provided, the jurisdiction will be determined as follows:
 - If the IC's estimate of the interstate traffic on the service involved constitutes 10 percent or less of the total traffic on that service, the service will be provided in accordance with the applicable rules and regulations of this Tariff.
 - If the IC's estimate of the interstate traffic on the service involved constitutes more than 10 percent of the total traffic on that service, the service will be provided in accordance with the applicable rules and regulations of the BellSouth Telecommunications, LLC Tariff FCC No. 1.

The IC shall keep records from which the percentage of interstate and intrastate use was estimated and upon request of the Company make the records available for inspection as reasonably necessary for purposes of verification of the percentages. The IC shall supply the data within 30 days of the Company request.

Note 1: Except where indicated herein, references to BellSouth SWA FGs will also include the applicable BellSouth SWA Basic Serving Arrangement as detailed in the matrix in Section 6.1.3 of Tariff FCC No. 1 (e.g., the term BellSouth SWA FGA represents both BellSouth SWA FGA and BellSouth SWA LSBSA). (C)

BELLSOUTH
 TELECOMMUNICATIONS
 KENTUCKY
 ISSUED: June 17, 2013
 BY: Tony Taylor, Executive Director
 Louisville, Kentucky

ACCESS SERVICES TARIFF

PSC KY. TARIFF 2E
 Ninth Revised Page 8.1
 Cancels Eighth Revised Page 8.1
 EFFECTIVE: July 2, 2013

E2. GENERAL REGULATIONS

E2.3 Obligations Of The Customer (Cont'd)

E2.3.14 Jurisdictional Report Requirements¹ (Cont'd)

B. Jurisdictional Report Verification

1. When a customer provides a projected interstate usage percent as set forth in A. preceding, or when a billing dispute arises or a regulatory commission questions the projected interstate percentage for BellSouth SWA, the Company may, by written request, require the customer to provide the data the customer used to determine the projected interstate percentage. *In the case of a third-party provider of CCS7 service to Third Party Customers as described in A. preceding, the data will include the data provided by the Third Party Customers.* This written request will be considered the initiation of the audit. The customer shall supply the data to an independent auditor within thirty days of the Company request. The customer shall keep records of call detail from which the percentage of interstate and intrastate use can be ascertained as set forth in C. following and upon request of the Company make the records available for inspection at an agreed upon location during normal business hours as reasonably necessary for purposes of verification of the percentages. The Company will audit data from one quarter unless a longer period is requested by the customer and agreed to by the Company. Changes to the reported PIU will not be made for the test period. If the customer does not provide the requested data to the Company or independent auditor within thirty (30) days of the notice of audit, the customer will be in violation of this Tariff and subject to E2.1.8 preceding.
2. For BellSouth SWA service, verification audits may be conducted no more frequently than once per year except in extreme circumstances. The Company and customer will attempt to limit the audit to a reasonable time to effectively complete the audit. The Company and customer shall respond promptly to requests generated during the audit to ensure timely completion of the audit.

The Company will work cooperatively with other Local Exchange Companies to develop joint audits of a customer in an effort to limit a customer's total state PIU audit to one per year.

3. Audits may be conducted by: (a) an independent auditor under contract to the Company; (b) a mutually agreed upon independent auditor; or (c) an independent auditor selected and paid for by the customer. If the customer selects option (c), where it pays for its own independent audit, the selected auditor must certify that the audit was performed following FCC procedures for measuring interstate and intrastate traffic as established by Commission Orders, and provide to the Company a report with supporting documentation to verify such procedures.

Note 1: Except where indicated herein, references to BellSouth SWA FGs will also include the applicable BellSouth SWA Basic Serving Arrangement as detailed in the matrix in Section 6.1.3 Tariff FCC No. 1 (e.g., the term BellSouth SWA FGA represents both BellSouth SWA FGA and BellSouth SWA LSBSA). (C)
 (C)

BELLSOUTH
 TELECOMMUNICATIONS
 KENTUCKY
 ISSUED: June 17, 2013
 BY: Tony Taylor, Executive Director
 Louisville, Kentucky

ACCESS SERVICES TARIFF

PSC KY. TARIFF 2E
 Second Revised Page 8.2
 Cancels First Revised Page 8.2
 EFFECTIVE: July 2, 2013

E2. GENERAL REGULATIONS

E2.3 Obligations Of The Customer (Cont'd)

E2.3.14 Jurisdictional Report Requirements¹ (Cont'd)

B. Jurisdictional Report Verification (Cont'd)

4. If a billing dispute arises or a regulatory commission questions the projected interstate percentage for Special Access (*a.k.a. BellSouth SPA*) service, the Company will ask the customer to provide the data the customer uses to determine the projected interstate percentage. The customer shall supply the data within thirty days of the Company request to an independent auditor. The customer shall keep records from which the percentage was determined and upon request of the Company make the records available for inspection as reasonably necessary for purposes of verification of the percentages.

C. Maintenance of Customer Records for *BellSouth SWA*

1. The customer shall retain for a minimum of six (6) months call detail records that substantiate the interstate percent provided to the Company as set forth in A. preceding for *BellSouth SWA* service. Such records shall consist of a. and b., (if applicable,) following:
 - a. All call detail records such as workpapers and/or backup documentation including paper, magnetic tapes or any other form of records for billed customer traffic, call information including call terminating address (i.e., called number), the call duration, all originating and terminating trunk groups or access lines over which the call is routed, and the point at which the call enters the customer's network and;
 - b. If the customer has a mechanized system in place that calculated the PIU, then a description of that system and the methodology used to calculate the PIU must be furnished and any other pertinent information (such as but not limited to flowcharts, source code, etc.) relating to such system must also be made available.

D. Audit Results for *BellSouth SWA*

1. Audit results will be furnished to the customer via Certified U.S. Mail (return receipt requested.) The Company will adjust the customer's PIU based upon the audit results. The PIU resulting from the audit shall be applied to the usage for the quarter the audit was completed, the usage for the quarter prior to completion of the audit, and to the usage for the two (2) quarters following the completion of the audit. After that time, the customer may report a revised PIU pursuant to A. preceding. If the revised PIU submitted by the customer represents a deviation, five percentage points or more, from the audited PIU, and that deviation is not due to identifiable reasons, the provisions in B. preceding will be applied.
2. Both credit and debit adjustments will be made to the customer's interstate and intrastate access charges for the specified period to accurately reflect the usage for the customer's account consistent with Section E2.4.1 following.
3. If, as a result of an audit conducted by an independent auditor, under contract to the Company, a customer is found to have overstated the PIU by twenty percentage points or more, the Company shall require reimbursement from the customer for the cost of the audit. Such bill(s) shall be due and paid in immediately available funds thirty days from receipt and shall carry a late payment penalty as set forth in E2.4.1 following.

Note 1: Except where indicated herein, references to *BellSouth SWA FGs* will also include the applicable *BellSouth SWA* Basic Serving Arrangement as detailed in the matrix in Section 6.1.3 of Tariff FCC No. 1 (e.g., the term *BellSouth SWA* FGA represents both *BellSouth SWA* FGA and *BellSouth SWA* LSBSA).

(C)

BELLSOUTH
 TELECOMMUNICATIONS
 KENTUCKY
 ISSUED: June 17, 2013
 BY: Tony Taylor, Executive Director
 Louisville, Kentucky

ACCESS SERVICES TARIFF

PSC KY. TARIFF 2E
 Second Revised Page 8.3
 Cancels First Revised Page 8.3
 EFFECTIVE: July 2, 2013

E2. GENERAL REGULATIONS

E2.3 Obligations Of The Customer (Cont'd)

E2.3.14 Jurisdictional Report Requirements¹ (Cont'd)

E. Contested Audits

1. When a PIU audit is conducted by an independent auditor selected by the Company, the audit results will be furnished to the customer by Certified U.S. Mail (return receipt requested). The customer may contest the audit results based on substantive cause by providing written notification, by Certified U.S. Mail (return receipt requested), to the Company within thirty (30) calendar days from the date the audit report is furnished to the customer by Certified U.S. Mail. When a PIU audit is conducted by an independent auditor selected by the customer, the audit results will be furnished to the Company by Certified U.S. Mail (return receipt requested). The Company may contest the audit results by providing written notification, by Certified U.S. Mail (return receipt requested), to the customer within thirty (30) calendar days from the date the audit report is furnished to the Company by Certified U.S. Mail.
2. Contested audits may be resolved by a neutral arbitrator mutually agreed upon by the Company and the customer. Arbitration is an option provided in addition to the customer's existing right to file a complaint or legal action in a court of law or at the Commission for resolution of the dispute. The arbitration hearing will be conducted in a state or location within the Company operating territory where the customer maintains a principle or significant presence, as mutually agreed upon by both parties, or a state and location within the Company operating territory that is mutually agreed upon by both parties. The arbitration proceeding shall be governed by the law (both statutory and case) of the state in which the arbitration hearing is held, including, but not limited to, the Uniform Arbitration Act, as adopted in that state. The arbitration shall determine the customer's PIU based on A. preceding.
3. Prior to the arbitration hearing, each party shall notify the arbitrator of the PIU percentage which that party believes to be correct. The arbitrator, in deciding, may adopt the PIU percentage of either party or may adopt a PIU percentage different from those proposed by the parties. If the arbitrator adopts a PIU percentage proposed by one of the parties, the other party (whose PIU percentage was not adopted) shall pay all costs of the arbitration. If the arbitrator adopts a PIU percentage higher than either of the PIU percentages proposed by the parties, then the party proposing the lower PIU percentage shall pay all costs of the arbitration. If the arbitrator adopts a PIU percentage lower than either of the PIU percentages proposed by the parties, then the party proposing the higher PIU percentage shall pay all costs of the arbitration. If the arbitrator adopts a PIU percentage which falls between the two percentages adopted by the parties, then the parties shall each pay one-half of the arbitration costs.
4. Absent written notification, within the time frame noted above, the customer must comply with the provisions set forth in D. preceding. If the customer fails to comply with these provisions, the Company may refuse additional applications for service and/or refuse to complete any and all pending orders for service or may discontinue the provision of the services to the customer as specified in E2.1.8 preceding.

Note 1: Except where indicated herein, references to *BellSouth SWA FGs* will also include the applicable *BellSouth SWA* Basic Serving Arrangement as detailed in the matrix in Section 6.1.3 of Tariff FCC No. 1 (e.g., the term *BellSouth SWA* FGA represents both *BellSouth SWA* FGA and *BellSouth SWA* LSBSA).

(C)

(C)

BELLSOUTH
TELECOMMUNICATIONS
KENTUCKY
ISSUED: June 17, 2013
BY: Tony Taylor, Executive Director
Louisville, Kentucky

ACCESS SERVICES TARIFF

PSC KY. TARIFF 2E
Eighth Revised Page 9
Cancels Seventh Revised Page 9
EFFECTIVE: July 2, 2013

E2. GENERAL REGULATIONS

E2.3 Obligations Of The Customer (Cont'd)

E2.3.15 Determination Of Intrastate Charges For Mixed Interstate And Intrastate Access Service¹

- A. When mixed interstate and intrastate Access Service is provided, all charges (i.e., nonrecurring, monthly and/or usage) including optional feature and Basic Service Element (BSE) charges, will be prorated between interstate and intrastate. The percentage provided in the reports as set forth in E2.3.14.A. preceding will serve as the basis for prorating the charges. The percentage of an Access Service to be charged as intrastate is applied in the following manner:
1. For monthly and nonrecurring chargeable rate elements, multiply the percent intrastate use times the quantity of chargeable elements times the stated tariff rate per element.
 2. For usage sensitive (i.e., access minutes and calls) chargeable rate elements, multiply the percent intrastate use times the actual use (i.e., measured or Company assumed average use) times the stated tariff rate.

The intrastate percentage will change as revised usage reports are submitted or as lines or trunks are added or removed as set forth in E2.3.14 preceding.

E2.3.16 Sectionalization - Trouble Reporting

The customer will be responsible for reporting troubles, sectionalized to Company facilities and/or equipment. When troubles cannot be clearly sectionalized to the Company facilities and/or equipment, the Company will test cooperatively or independently to assist in trouble sectionalization.

Responsibility for payment of additional charges will apply as set forth in Section E13.

E2.3.17 Reserved For Future Use

E2.3.18 Reserved For Future Use

E2.3.19 800 Number Reporting

For *BellSouth SWA 8XX Toll Free Dialing* Ten Digit Screening service the customer will be responsible for reporting to the Company or directly to the Service Management System 800 numbers that are in service in the Company serving area and the activation date of every 800 number assigned.

Additionally, the provision of *BellSouth SWA 8XX Toll Free Dialing* Ten Digit Screening service, provided from Section 6 of Tariff FCC No. 1, requires the customer's subscription to basic *BellSouth 8XX Number Administration* service features found in Section E13. of this Tariff or as an alternative the provision of those features by other responsible organizations or through direct access by the customer to the Service Management System.

(C)
(C)

Page reformatted pursuant to 807 KAR 5:011—Tariffs, Section 3 (4).

BELLSOUTH
TELECOMMUNICATIONS
KENTUCKY
ISSUED: April 28, 2014
BY: Hood Harris, President
Louisville, Kentucky

ACCESS SERVICES TARIFF

PSC KY. TARIFF 2E
Fifth Revised Page 9.1
Cancels Fourth Revised Page 9.1
EFFECTIVE: May 28, 2014

E2. GENERAL REGULATIONS**E2.3 Obligations Of The Customer (Cont'd)****E2.3.20 Identification and Rating of VoIP-PSTN Traffic****(A) Scope**

This Section applies to VoIP-PSTN Traffic exchanged between the Company and the customer in time division multiplexing ("TDM") format that originates and/or terminates in Internet protocol ("IP") format. VoIP-PSTN traffic originates and/or terminates in IP format if it originates from and/or terminates to an end-user customer of a service that requires Internet protocol-compatible customer premises equipment.⁽¹⁾

- (1) This Section governs the identification of originating and terminating intrastate toll VoIP-PSTN traffic and facilities to which switched access rates apply (unless the parties have agreed otherwise) in accordance with the transitional Inter-carrier Compensation framework for VoIP-PSTN traffic adopted by the Federal Communications Commission in its Report and Order, FCC Release No. 11-161 (Nov. 18, 2011) ("FCC Order"). Specifically, this Section establishes the method that will be used to identify the percentage of the customer's intrastate access traffic that will be treated as intrastate toll VoIP-PSTN traffic (referred to in this tariff as "Relevant VoIP-PSTN Traffic").
- (2) This Section applies to originating and terminating intrastate switched access minutes of use ("MOU") and facility rate elements of all Access customers.
- (3) The customer shall not modify its reported PIU factor to account for the VoIP-PSTN Traffic for MOU and facility rate elements.

(B) Rating of VoIP-PSTN Traffic

The Relevant VoIP-PSTN Traffic exchanged between the customer and the Company or another provider and facility rate elements identified in accordance with this tariff section will be billed at rates equal to the Company's applicable tariffed interstate switched access rates as specified in BellSouth Telecommunications LLC Tariff F.C.C. No. 1 unless the corresponding intrastate rate is lower. If the intrastate rate is lower, then that rate will be used for billing. Hereafter, these billed rates will be referred to in this tariff as the relevant "VoIP Rates."

(C) Calculation and Application of Percent-VoIP-Usage Factors⁽²⁾

The Company will determine the number of Relevant VoIP-PSTN Traffic originating MOU and the originating facility rate elements effective July 1, 2014 to which VoIP Rates will be applied under subsection (B), above, by applying the Percent VoIP Usage ("PVU") factor to the originating intrastate access MOU and the facilities between the Company and the customer. The PVU factors will be derived and applied as follows:

- (1) Although the Company has taken the position that this tariff, by its own terms, already applies to VoIP-PSTN traffic, as defined herein, the Company has included this Section in the tariff out of an abundance of caution to prevent any claim that it does not so apply, and to implement the decision by the Federal Communications Commission in its Report and Order in WC Docket Nos. 10-90, etc., FCC Release No. 11-161 (Nov. 18, 2011) ("FCC Order") that VoIP-PSTN access traffic should be exchanged at interstate access rates (unless the parties have agreed otherwise). By its terms, the FCC Order is prospective only, and does not address preexisting law with regard to the applicability of inter-carrier compensation or the enhanced service providers ("ESP") exemption to VoIP-PSTN Traffic. Including this section in the tariff in no way alters or otherwise affects the applicability of this tariff to VoIP-PSTN Traffic before the effective date of the FCC Order.
- (2) Consistent with FCC regulations (47 CFR 51.913(a)), for the period of July 2012 through June 2014 Intrastate VoIP originating usage and originating dedicated facilities charges are required to be at the Intrastate rate and rate structure. Effective July 1, 2013, the Terminating usage and dedicated facilities are at the Interstate rate structure and the lower of the Interstate or Intrastate rates.

BELLSOUTH
TELECOMMUNICATIONS
KENTUCKY
ISSUED: April 28, 2014
BY: Hood Harris, President
Louisville, Kentucky

ACCESS SERVICES TARIFF

PSC KY. TARIFF 2E
Third Revised Page 9.2
Cancels Second Revised Page 9.2
EFFECTIVE: May 28, 2014

E2. GENERAL REGULATIONS**E2.3 Obligations Of The Customer (Cont'd)**E2.3.20 Identification and Rating of VoIP-PSTN Traffic (Cont'd)(C) Calculation and Application of Percent-VoIP-Usage Factors (Cont'd)

(1) The customer will calculate and furnish to the Company a factor (the "PVUC") on an Access Customer Name Abbreviation ("ACNA") basis which would aggregate traffic from all Carrier Identification Code ("CIC") or Operating Company Numbers ("OCNs") associated with the ACNA. This PVUC represents the percentage (whole number) of the originating intrastate access MOU that the customer receives from the Company end users in the state which is sent from the Company that is terminated in IP format at the customer's end user. This PVUC shall be based on information such as the number of the customer's retail VoIP subscriptions in the state (e.g., as reported on FCC Form 477), traffic studies, actual call detail, or other relevant and verifiable information satisfactory to the Company. (C)

(2) The Company will calculate and periodically update a (the "PVUT") VOIP usage factor for the Company. This factor (percentage) is calculated on an individual state basis: the intrastate originating minutes delivered to the customer which were originated in IP format by the Company's end users divided by the total intrastate originating access MOU that the Company delivered to the customer's end users. This PVUT shall be based on information such as the number of the customer's retail VoIP subscriptions in the state (e.g., as reported on FCC Form 477), traffic studies, actual call detail, or other relevant and verifiable information. (C)

(3) The Company will develop a customer Percent VoIP Usage ("PVU") factor combining the customer's PVUC factor with the Company's PVUT factor. (T)

a) The PVU calculation below is applied when the Company does not bill based on actual call detail records for the Company's intrastate IP traffic at VoIP Rates. (T)

$PVU = PVUC + [PVUT \times (1 - PVUC)]$ is applied to the Company's end user's originating intrastate MOU and facility rate elements (C)

Example: The customer reported that their PVUC as 40%. The Company's PVUT is 10%. This results in the following:

$PVU = 40\% \text{ plus } (10\% \text{ times } (1 - 40\%)) = 46\%$

This means that 46% of the originating intrastate MOU exchanged between the Company's end users and the customer will be rated at VoIP Rates. (C)

b) The PVU calculation below is applied when the Company bills are based on the actual originating call detail records for the Company's intrastate IP traffic at VoIP Rates. (T)

The formula for usage will be as follows:

$PVU = PVUC \times (1 - PVUT)$ applied to the Company's TDM end user's originating intrastate MOU. (C)

$PVU = PVUC + [PVUT \times (1 - PVUC)]$ applied to the facility rate elements.

BELLSOUTH
TELECOMMUNICATIONS
KENTUCKY
ISSUED: April 28, 2014
BY: Hood Harris, President
Louisville, Kentucky

ACCESS SERVICES TARIFF

PSC KY. TARIFF 2E
Third Revised Page 9.3
Cancels Second Revised Page 9.3
EFFECTIVE: May 28, 2014

E2. GENERAL REGULATIONS**E2.3 Obligations Of The Customer (Cont'd)**E2.3.20 Identification and Rating of VoIP-PSTN Traffic (Cont'd)(C) Calculation and Application of Percent VoIP Usage Factors (Cont'd)

(3) (Cont'd)

(b) (Cont'd)

Example: The Company has identified that there were 10,500 originating intrastate MOU from the Company's IP end users and delivered to the customer's end users. The customer reported that their PVUC as 40%. The Company's PVUT is 10%. This results in the following: (C)

$$PVU = 40\% \text{ times } (1-10\%) = 36\%$$

This means that 36% of the originating intrastate MOU exchanged between the Company's TDM end users and the customer will be rated at VoIP Rates and the originating intrastate 10,500 MOU will also be rated at VoIP Rates. (C)

For the originating facility rate elements, the formula that is applied to the intrastate dedicated facilities is as follows: (C)

$$PVU = 40\% \text{ plus } (10\% \text{ times } (1-40\%)) = 46\%$$

Therefore, 46% of the originating intrastate facilities will be rated at VoIP Rates. (C)

- (4) The Company will apply the customer's PVUC to originating traffic exchanged between the third party providers (e.g. Independent Company and local exchange carrier) subtending the Company's access tandem and the customer. (C)

The customer may elect to provide a different factor ("PVUC3") that represents the originating VoIP-PSTN traffic that is exchanged between the third party providers and the customer (C)

- (5) If the customer does not furnish the Company with a PVUC pursuant to the preceding paragraph (C) (1), the Company will utilize a customer PVUC of 0%. (C)

(D) PVU Factor Updates

The customer may update the PVUC factor quarterly using the method set forth in Subsection (C)(1) and (4), above. If the customer chooses to submit such updates, it shall forward to the Company, no later than 15 days after the first day of January, April, July and/or October of each year, a revised PVUC factor based on data for the prior three months, ending the last day of December, March, June and September, respectively. The Company will use the revised PVUC to calculate a revised PVU. The revised PVU factor will only apply prospectively and serve as the basis for billing until superseded by a new PVU.

The customer must update the PVUC factor no later than June 1, 2014 to reflect the use of originating VOIP traffic as delineated in Subsection (C)(1) and (4) or the Company will utilize a customer PVUC of 0%. (C)

(E) PVU Factor Verification

Not more than twice in any year, the Company may ask the customer to verify the PVUC factor furnished to the Company. The customer shall comply, and shall reasonably provide the records and other information used to determine their PVUC, as specified in section (C) (1), and (4), above. The customer shall retain and maintain (for verification purposes) the records and other information used to determine the PVUC, for at least 12 months after the PVUC is filed (or longer if any other section of the Company's tariffs or applicable law requires a longer period). The verification process shall be conducted consistent with the provisions in Section 2.3.10(B) (D) (E) of BellSouth Telecommunications LLC Tariff F.C.C. No. 1.

BELLSOUTH
TELECOMMUNICATIONS
KENTUCKY
ISSUED: June 17, 2013
BY: Tony Taylor, Executive Director
Louisville, Kentucky

ACCESS SERVICES TARIFF

PSC KY. TARIFF 2E
First Revised Page 9.4
Cancels Original Page 9.4
EFFECTIVE: July 2, 2013

E2. GENERAL REGULATIONS

E2.3 Obligations Of The Customer (Cont'd)

E2.3.20 Identification and Rating of VoIP-PSTN Traffic (Cont'd)

(F) Verification Process

The Telephone Company will review these customer-provided PVUC records referenced in (E), above. If the review results represent what the Telephone Company considers to be a substantial deviation from the customer's previously reported PVUC or if the PVUC appears unreasonable as compared to other related types of data, the Telephone Company will contact the customer within 30 days. This deviation issue will be dealt with in one of the following ways. The current PVUC will continue to be utilized until resolution from either of the 2 methods below.

- 1) The Telephone Company and the customer will come to an agreement as to an appropriate PVUC within 30 days of the provision of the PVUC records.
- 2) Within 90 days of the receipt of these records, the Telephone Company will review or audit these records. If these PVUC records are not available or these records are not substantive enough to calculate a PVUC, then a PVUC factor of zero will be assigned. This zero PVUC will be utilized until either a PVUC can be agreed upon between the Telephone Company and the customer or an audit can be completed utilizing records acceptable for an audit conclusion. When an audit has been completed employing the records acceptable for an audit conclusion, the PVUC resulting from the audit will be employed until the next customer-provided PVUC is available as referenced in the (D) or (E) procedures above.

(M)

(M)

E2.3.21 Utilization of Alternative Access Providers

When the customer of record for an access service utilizes the service(s) of an alternative access provider, it will be the obligation of the customer to monitor the actions of the alternative access provider to insure that the customer's desired service interconnections and grades of service are maintained.

Note 1: Except where indicated herein, references to *BellSouth SWA FGs* will also include the applicable *BellSouth SWA* Basic Serving Arrangement as detailed in the matrix in Section 6.1.3 of Tariff FCC No. 1 (e.g., the term *BellSouth SWA* FGA represents both *BellSouth SWA* FGA and *BellSouth SWA* LSBSA).

E2.4 Payment Arrangements And Credit Allowances

E2.4.1 Payment Of Rates, Charges And Deposits

- A. The Company will, in order to safeguard its interests, only require a customer which has a proven history of late payments to the Company or does not have established credit to make a deposit prior to or at any time after the provision of a service to the customer to be held by the Company as a guarantee of the payment of rates and charges.

The Company will notify the customer of a deposit requirement by Certified Mail or Overnight Delivery. The customer will be required to make payment of such deposit prior to the provision of new service in those cases where the customer has not established credit with the Company, or otherwise within fifteen (15) days of such notice for customers with existing services. Such notice period will start the day after the notice is rendered by Certified Mail or Overnight Delivery.

Page reformatted pursuant to 807 KAR 5:011—Tariffs, Section 3 (4).

BELLSOUTH
 TELECOMMUNICATIONS
 KENTUCKY
 ISSUED: June 17, 2013
 BY: Tony Taylor, Executive Director
 Louisville, Kentucky

ACCESS SERVICES TARIFF

PSC KY. TARIFF 2E
 Original Page 9.5

EFFECTIVE: July 2, 2013

E2. GENERAL REGULATIONS**E2.4 Payment Arrangements And Credit Allowances**

(M)

E2.4.1 Payment Of Rates, Charges And Deposits

No such deposit will be required of a customer which is a successor of a company which has established credit and has no history of late payments to the Company. Such deposit may not exceed the actual or estimated rates and charges for the service for a two month period. The fact that a deposit has been made in no way relieves the customer from complying with the Company's regulations as to the prompt payment of bills. At such time as the provision of the service to the customer is terminated, the amount of the deposit will be credited to the customer's account and any credit balance which may remain will be refunded.

Such a deposit will be refunded or credited to the customer's account when the customer has established credit or, in any event, after the customer has established a one-year prompt payment record at any time prior to the termination of the provision of the service to the customer. In case of a cash deposit, for the period the deposit is held by the Company, the customer will receive simple interest at the same percentage rate as that set forth in B.3.b.(1) or (2) following whichever is lower. The rate will be compounded daily for the number of days from the date the customer's deposit is received by the Company to and including the date such deposit is credited to the customer's account or the date the deposit is refunded by the Company. Should a deposit be credited to the customer's account, as indicated preceding, no interest will accrue on the deposit from the date such deposit is credited to the customer's account.

(M)

Page reformatted pursuant to 807 KAR 5:011—Tariffs, Section 3 (4).

BELLSOUTH
TELECOMMUNICATIONS
KENTUCKY
ISSUED: January 17, 1997
BY: Hood Harris, President
Louisville, Kentucky

ACCESS SERVICES TARIFF

PSC KY. TARIFF 2E
Third Revised Page 10
Cancels Second Revised Page 10
EFFECTIVE: February 16, 1997

E2. GENERAL REGULATIONS**E2.4 Payment Arrangements And Credit Allowances (Cont'd)****E2.4.1 Payment Of Rates, Charges And Deposits (Cont'd)**

- B.** The Company shall bill on a current basis all charges incurred by and credits due to the customer under this Tariff attributable to services, including, but not limited to maintenance of service as set forth in E13.3.1 following, established or discontinued during the preceding billing period. In addition, the Company shall bill in advance charges for all services to be provided during the ensuing billing period except for charges associated with service usage and for the Federal Government which will be billed in arrears. The bill day (i.e., the billing date of a bill for a customer for Access Service under this Tariff), the period of service each bill covers and the payment date will be as follows:
1. For End User Access service and for **BellSouth Equal Access Subscription** service, the Company will establish a bill day each month for each end user account. The bill will cover End User Access service charges for the ensuing billing period except for End User Access service for the Federal Government which will be billed in arrears. Any applicable **BellSouth Equal Access Subscription** charges, any know unbilled charges for prior periods and any known unbilled adjustments for prior periods for the End User Access service and **BellSouth Equal Access Subscription** service will be applied to this bill. Such bills are due when rendered. (T)
 2. For services other than End User Access service and **BellSouth Equal Access Subscription** service, the Company will establish a bill day each month for each customer account. The customer will receive a monthly bill for services provided by the Company. The bill will include the subscriber's billing account number, the due date of the bill, the amount due, the period of time covered by the bill, and itemized charges as appropriate. The bill will cover nonusage sensitive service charges for the ensuing billing period for which the bill is rendered, any known unbilled nonusage sensitive charges for prior periods and unbilled usage charges for the period after the last bill day through the current bill day. Any known unbilled usage charges for prior periods and any known unbilled adjustments will be applied to this bill. Payment for such bills is due as set forth in 3. following. If payment is not received by the payment date, as set forth in 3. following in immediately available funds, a late payment penalty will apply as set forth in 3. following. (T)
 3. Payment Due Date
 - a. All bills dated as set forth in 2. preceding for service, other than End User Access service and **BellSouth Equal Access Subscription** service, provided to the customer by the Company are due on the payment due date. The payment due date is the date which is 31 days after the bill day or by the next bill date (i.e., same date in the following month as the bill date), whichever is the shortest interval, except as provided herein, and are payable in immediately available funds. If such payment date would cause payment to be due on a Saturday, Sunday or Holiday (i.e., New Year's Day, Independence Day, Labor Day, Thanksgiving Day, Christmas Day, and a day when Washington's Birthday, Memorial Day or Columbus Day is legally observed), payment for such bills will be due from the customer as follows:

If such payment date falls on a Sunday or on a Holiday which is observed on a Monday, the payment due date shall be the first non-Holiday day following such Sunday or Holiday. If such payment due date falls on a Saturday or on a Holiday which is observed on Tuesday, Wednesday, Thursday or Friday, the payment due date shall be the last non-Holiday day preceding such Saturday or Holiday.
 - b. Further, if any portion of the payment is received by the Company after the payment due date as set forth in a. preceding, or if any portion of the payment is received by the Company in funds which are not immediately available to the Company, then a late payment penalty shall be due to the Company. The late payment penalty shall be the portion of the payment not received by the payment due date times a late factor. The late factor shall be the lesser of:
 - (1) The highest finance charge (in decimal value) which may be levied by law for commercial transactions or public utilities, compounded daily for the number of days from the first date to and including the last date of the period involved, or
 - (2) 0.000590 per day, compounded daily for the number of days from the first date to and including the last date of the period involved.

BELLSOUTH
TELECOMMUNICATIONS
KENTUCKY
ISSUED: June 17, 2013
BY: Tony Taylor, Executive Director
Louisville, Kentucky

ACCESS SERVICES TARIFF

PSC KY. TARIFF 2E
Fourth Revised Page 11
Cancels Third Revised Page 11
EFFECTIVE: July 2, 2013

E2. GENERAL REGULATIONS**E2.4 Payment Arrangements And Credit Allowances (Cont'd)****E2.4.1 Payment Of Rates, Charges And Deposits (Cont'd)****B. (Cont'd)**

- c. In the event of a billing dispute, the customer must submit a documented claim for the disputed amount. If the dispute is submitted on or before the payment due date or within 90 days after the payment due date and the disputed amount is paid prior to the resolution of the dispute, any interest credits due the customer upon resolution of the dispute shall be calculated from the date of the overpayment to the resolution date. If the dispute is submitted more than 90 days after the payment due date and the disputed amount is paid prior to resolution of the dispute, and interest credits due the customer upon resolution of the dispute shall be calculated from the dispute date or the date the payment is made, whichever occurs later, to the resolution date. The Company will resolve the dispute and assess interest credits or late payment penalties to the customer as follows.

If the dispute is resolved in favor of the Company and the customer has paid the disputed amount on or before the payment due date, no credits or late payment penalties will apply to the disputed amount.

If the dispute is resolved in favor of the Company and the customer has withheld the disputed amount, any payments withheld pending settlement of the dispute shall be subject to the late payment penalty as set forth in b. preceding.

If the dispute is resolved in favor of the customer and the customer has withheld the disputed amount, no credits or late payment penalties will apply to the disputed amount.

If the dispute is resolved in favor of the customer and the customer has paid the disputed amount, the customer will receive a credit from the Company for the disputed amount times a penalty factor as set forth preceding. The penalty factor shall be the lesser of:

If the billing dispute is resolved in favor of the customer, no late payment penalty will apply to the disputed amount. In addition, if the customer disputes the billed amount and pays the total amount (i.e., the nondisputed amount and the disputed amount) on or before the payment date and the billing dispute is resolved in the favor of the customer, the customer will receive a credit for a disputed amount penalty from the Company if the billing dispute is not resolved within 10 working days following the payment date or the date the customer furnishes to the Company documentation to support its claim plus 10 working days, whichever date is the later date. The disputed amount penalty shall be the disputed amount resolved in the customer's favor times a penalty factor. The penalty factor shall be the lesser of:

- (1) The highest interest rate (in decimal value) which may be levied by law for commercial transactions or public utilities, compounded daily for the number of days from the first date to and including the last date of the period involved, or
- (2) 0.000590 per day, compounded daily for the number of days from the first date to and including the last date of the period involved.

If a customer's traffic terminates to an end office via an alternative Tandem Service Provider (TSP), any terminating usage dispute for that end office must identify the quantity of MOUs the customer's records indicate to be terminated via an alternative TSP.

Upon receipt of the dispute involving usage terminated via an alternative TSP, the Company will verify that the disputed bill accurately represents the information provided to the Company pursuant to Section 6.6.5 of Tariff FCC No. 1, within 5 days of receipt of a dispute notification. (C)

If the billing agrees with the billing data received pursuant to Section 6.6.5 of Tariff FCC No. 1, the Company will refer the dispute to the entity providing the billing date information within 16 days from the date the dispute was received. (C)

Page reformatted pursuant to 807 KAR 5:011—Tariffs, Section 3 (4).

BELLSOUTH
 TELECOMMUNICATIONS
 KENTUCKY
 ISSUED: June 17, 2013
 BY: Tony Taylor, Executive Director
 Louisville, Kentucky

ACCESS SERVICES TARIFF

PSC KY. TARIFF 2E
 First Revised Page 11.0.0.1
 Cancels Original Page 11.0.0.1
 EFFECTIVE: July 2, 2013

E2. GENERAL REGULATIONS**E2.4 Payment Arrangements And Credit Allowances (Cont'd)****E2.4.1 Payment Of Rates, Charges And Deposits (Cont'd)****B. (Cont'd)**

c. (Cont'd)

The provider of the billing data information will investigate the claim and reply to the Company within 15 days of the referral.

The provider of the billing data information, the customer and the Company will work cooperatively to resolve any remaining discrepancies.

If the entity providing the billing data information fails to cooperate with the Company to resolve billing disputes involving usage billed based on the billing data information received, the Company may refuse to accept future billing data information and bill the full terminating charges for all usage to the alternative TSP.

The terms and conditions in E2.4.1.B.3.c. preceding still apply except for the following:

- If the Company accurately billed the usage as contained in the billing data information provided to it, the Company will not be liable for any interest due the customer for overpayment if the dispute is resolved in the customer's favor.

- C. When a payment for Access Service Charges billed under this Tariff is due to the Company from the customer as set forth in B.3. preceding on the same payment date that a Purchase of Accounts Receivable net purchase amount is due to the customer from the Company as set forth in E8.2.3 following, the Company may, with at least 31 days notice to the customer, net the payment for customer Access Service Charges with the net purchase amount. The Company will pay the net amount to the customer on the payment date when such net amount is due to the customer or require the customer to pay to the Company the net amount when such net amount is due to the Company. If either party does not make the payment on the payment date, a late payment penalty as set forth in E8.2.3.A.3. following or B.3. preceding, whichever is appropriate, applies.

(M)

(M)

Page reformatted pursuant to 807 KAR 5:011—Tariffs, Section 3 (4).

BELLSOUTH
TELECOMMUNICATIONS
KENTUCKY
ISSUED: January 17, 1997
BY: Hood Harris, President
Louisville, Kentucky

ACCESS SERVICES TARIFF

PSC KY. TARIFF 2E
First Revised Page 11.0.1
Cancels Original Page 11.0.1
EFFECTIVE: February 16, 1997

E2. GENERAL REGULATIONS**E2.4 Payment Arrangements And Credit Allowances (Cont'd)****E2.4.1 Payment Of Rates, Charges And Deposits (Cont'd)**

- D.** Adjustments for the quantities of services established or discontinued in any billing period beyond the minimum period set forth for services in other sections of this Tariff will be prorated based on number of days the customer had service during the billing period times 1/30th the monthly rate. Billing for service begins on the day following the date of installation and shall accrue through and including the day service is discontinued. The Company will, upon request and if available, furnish such detailed information as may reasonably be required for verification of any bill, including information relative to the development of the subscriber line ratio.
- E.** When a rate as set forth in this Tariff is shown to more than two decimal places, the charges will be determined using the rate shown. The resulting amount will then be rounded to the nearest penny (i.e., rounded to two decimal places).
- F.** When more than one copy of a customer bill for services provided under the provisions of this Tariff is furnished to the customer, an additional charge applies for each additional copy of the bill as set forth in E13.3.6. following.
- G.** The dispute date is the date the customer presents sufficient documentation to support the claim. Sufficient documentation consist of the following information, where such information is relevant to the dispute and reasonably available to the customer:
1. **Special Access (a.k.a. BellSouth SPA)** (T)
 - The nature of the dispute (i.e., incorrect rate, incorrect circuit type etc.), including the basis for the customer's belief that the bill is incorrect.
 - The billing account number(s) assigned by the Company.
 - The amount of money in dispute.
 - The date of the bill in dispute.
 2. **BellSouth SWA (Non-Usage)** (T)
 - The nature of the dispute (i.e., incorrect rate etc.), including the basis for the customer's belief that the bill is incorrect.
 - The billing account number(s) assigned by the Company.
 - The amount of money in dispute.
 - The date of the bill in dispute.
 3. **BellSouth SWA (Usage)** (T)
 - The nature of the dispute (i.e., incorrect rate, incorrect minutes of use, etc.), including the basis for the customer's belief that the bill is incorrect.
 - The type of usage (i.e., originating or terminating).
 - The Company end office where the minutes of use originated or terminated (if applicable).
 - The number of minutes in dispute.
 - The billing account number(s) assigned by the Company.
 - The amount of money in dispute.
 - The date of the bill.

BELLSOUTH
 TELECOMMUNICATIONS, INC.
 KENTUCKY
 ISSUED: February 7, 2005
 BY: E.C. Roberts, Jr., President - KY
 Louisville, Kentucky

ACCESS SERVICES TARIFF

PSC KY. TARIFF 2E
 Fifth Revised Page 11.1
 Cancels Fourth Revised Page 11.1
 EFFECTIVE: March 9, 2005

E2. GENERAL REGULATIONS**E2.4 Payment Arrangements And Credit Allowances (Cont'd)****E2.4.1 Payment Of Rates, Charges And Deposits (Cont'd)**

- H.** The Company and the customer shall work cooperatively to resolve the dispute.
 If additional information from the customer would assist in resolving the dispute, the customer may be requested to provide additional information relevant to the dispute and reasonably available to the customer. This data may include, but is not limited to summarized usage data by time of day. The request for such additional information shall not affect the dispute date established pursuant to F. preceding.
- I.** For purposes of E2.4.1.B.3.c. preceding, the resolution date is the date on which the Company completes the investigation of the dispute, and the Company's service representative notifies the customer of the disposition and notes the customer's account or when the Company forwards the amount of credit to the customer, depending upon customer preference.
- J.** At the option of the IC or end user, all nonrecurring charges associated with a Standard or Negotiated Interval Access Order may be billed over a three month period subject to the following:
- 50 percent of the total nonrecurring charges will be billed in the first monthly billing period after the charges are incurred, and 25 percent of the total nonrecurring charges plus an Extended Billing Plan Charge will be billed in each of the following two monthly billing periods.
 - The Extended Billing Plan Charge is calculated at a rate of 1.0 percent per month or 12 percent annually, on the unbilled balance of the nonrecurring charges.
 - The IC or end user must request extended billing at the time the Access Service request is placed for a Standard or Negotiated Interval Access Order.
 - If the IC or end user disconnects service before the expiration of the plan period, all unbilled charges plus the Extended Billing Plan Charge, if applicable, will be included in the final bill rendered.
 - If the IC or end user fails to make any of the payments on the payment due date as set forth in E2.4.1. preceding, late payment charges as specified in E2.4.1. preceding will apply.

E2.4.2 Minimum Periods

- A.** The minimum period for which services are provided and for which rates and charges are applicable is one month except for those services as set forth in *E7.4.32.A.1.*, E7.7, E8.2.1.E.2., E8.2.2.E.2., E13.3.5.F.1.b., c. and d., and E29.1.2 of this Tariff. (C)

BELLSOUTH
TELECOMMUNICATIONS
KENTUCKY
ISSUED: December 16, 2022
BY: Cyndi Gallagher, Director – External Affairs

ACCESS SERVICES TARIFF

PSC KY. TARIFF 2E
Tenth Revised Page 12
Cancels Ninth Revised Page 12
EFFECTIVE: January 1, 2023

E2. GENERAL REGULATIONS**E2.4 Payment Arrangements And Credit Allowances (Cont'd)****E2.4.2 Minimum Periods (Cont'd)**

- B. The minimum period for which service is provided and for which rates and charges are applicable for a Specialized Service or Arrangement provided on an individual case basis, as set forth in E12. following, is one month unless a different minimum period is established with the individual case filing.
- C. When a service is discontinued prior to the expiration of the minimum period, charges are applicable whether the service is used or not, as follows:
 1. When a service with a one month minimum period is discontinued prior to the expiration of the minimum period, a one month charge will apply at the rate level in effect at the time service is discontinued.
 2. Except for High Capacity (a.k.a. BellSouth SPA High Capacity) Individual Case Basis (ICB) services and associated channelization listed in Sections E7. and E12., and for Channel Services Payment Plan(s) (CSPP), when a service with a minimum period greater than one month is discontinued prior to the expiration of the minimum period, the applicable charge will be the lesser of the Company's total nonrecoverable costs less the net salvage value for the discontinued service, or the total monthly charges, at the rate level in effect at the time service is discontinued, for the remainder of the minimum period.
 3. When a High Capacity (a.k.a. BellSouth SPA High Capacity) Individual Case Basis (ICB) Service(s) and associated channelization listed in Sections E7. and E12. is disconnected prior to the expiration of the minimum period, the termination charge as specified in the High Capacity (a.k.a. BellSouth SPA High Capacity) Individual Case Basis filing will apply.
 4. When channel equipment and or facilities are disconnected from a customer network, prior to the expiration of a Channel Services Payment Plan period, a termination charge under conditions specified in E2.4.9 will apply.
- D. The minimum service periods for BellSouth Custom Network services and applicable rates and charges are provided in E7.7 for each arrangement. Regulations and applicable charges for disconnects and moves of service prior to the expiration of the minimum period are also specified in E7.7.

E2.4.3 Cancellation Of An Order For Service

Provisions for the cancellation of an Access Order for BellSouth SWA or Special Access (a.k.a. BellSouth SPA) service are set forth in E5.2.4 following.

E2.4.4 Credit Allowance For Service Interruptions**A. General**

A service is interrupted when it becomes unusable to the customer because of a failure of a facility component used to furnish service under this Tariff or in the event that the protective controls applied by the Company result in the complete loss of service by the customer as set forth in Section 6.5.1 of Tariff FCC No. 1. An interruption period starts when the customer reports the interruption to the Company, and ends when the service is operative.

B. When a Credit Allowance Applies

In case of an interruption to any service, allowance for the period of interruption, if not due to the negligence of the customer, shall be as follows:

1. For BellSouth SWA Dedicated Interoffice Channels, Channelization Equipment and Switched Local Channel, Dedicated End Office Trunk Port Service and Dedicated Tandem Trunk Port Special Access (a.k.a. BellSouth SPA) services, no credit shall be allowed for an interruption of less than thirty minutes. The customer shall be credited for an interruption of thirty minutes or more at the rate of 1/1440 of the monthly charges for the facility or service for each period of thirty minutes or major fraction thereof that the interruption continues. (D)

BELLSOUTH
TELECOMMUNICATIONS, INC.
KENTUCKY
ISSUED: January 30, 1998
BY: E.C. Roberts, Jr., President - KY
Louisville, Kentucky

ACCESS SERVICES TARIFF

PSC KY. TARIFF 2E
Third Revised Page 12.1
Cancels Second Revised Page 12.1
EFFECTIVE: February 1, 1998

E2. GENERAL REGULATIONS**E2.4 Payment Arrangements And Credit Allowances (Cont'd)****E2.4.4 Credit Allowance For Service Interruptions (Cont'd)****B. When a Credit Allowance Applies (Cont'd)**

1. (Cont'd)

The monthly charges used to determine the credit shall be as follows:

- a. The monthly charge shall be the total of all the monthly rate element charges associated with the service:
 - (1) For BellSouth SWA Transport: Local Channel, *Dedicated End Office Trunk Port Service and Dedicated Tandem Trunk Port Service*, BellSouth SWA Dedicated Interoffice Channel, Channelization Equipment (if applicable), and any Optional Features and Functions. (C)
 - (2) For Special Access (a.k.a. BellSouth SPA) two-point services: two Local Channels, Interoffice Channel and Optional Features and Functions.
- b. For multipoint services, the monthly charge shall be only the total of all the monthly rate element charges associated with that portion of the service that is inoperative (i.e., a local channel per customer premises, interoffice channel and optional features and functions.)

BELLSOUTH
 TELECOMMUNICATIONS
 KENTUCKY
 ISSUED: December 16, 2022
 BY: Cyndi Gallagher, Director – External Affairs

ACCESS SERVICES TARIFF

PSC KY. TARIFF 2E
 Ninth Revised Page 13
 Cancels Eighth Revised Page 13
 EFFECTIVE: January 1, 2023

E2. GENERAL REGULATIONS

E2.4 Payment Arrangements And Credit Allowances (Cont'd)

E2.4.4 Credit Allowance For Service Interruptions (Cont'd)

B. When a Credit Allowance Applies (Cont'd)

1. (Cont'd)

- c. For Special Access (a.k.a. BellSouth SPA) services, the monthly charge shall be the total of all the monthly rate element charges associated with that portion of the service that is inoperative. When the facility which is channelized or the Basic Channelization System itself is inoperative, the monthly charge shall be the total of all the monthly rate element charges associated with the service (i.e., the local channel, interoffice channel and optional features and functions, including the Basic Channelization System on the facility to the Hub, and the local channels, interoffice channels and their associated Central Office Channel Interface(s) and optional features and functions on the individual services from the Hub). When the service which rides a channel of the channelized facility is inoperative, the monthly charge shall be the total of all the monthly rate element charges associated with that portion of the service from the Hub to a customer premises (i.e., local channels, interoffice channel, Central Office Channel Interface, and optional features and functions).
- d. For BellSouth SWA channelized services, the monthly charge shall be the total of all monthly rate element charges associated with that portion of the service that is inoperative. When the facility which is channelized or the Basic Channelization System itself is inoperative, the monthly charge shall be the total of all the monthly rate element charges associated with the service (e.g., the Switched Local Channel, Switched Interoffice Channels, Channelization Equipment, including the Basic Channelization System on the facility to the Hub, if applicable).

2. *Reserved For Future Use*

(T)(D)

BELLSOUTH
TELECOMMUNICATIONS
KENTUCKY
ISSUED: October 30, 2014
BY: Hood Harris, President
Louisville, Kentucky

ACCESS SERVICES TARIFF

PSC KY. TARIFF 2E
Sixth Revised Page 13.1
Cancels Fifth Revised Page 13.1
EFFECTIVE: November 14, 2014

E2. GENERAL REGULATIONS**E2.4 Payment Arrangements And Credit Allowances (Cont'd)****E2.4.4 Credit Allowance For Service Interruptions (Cont'd)****B. When a Credit Allowance Applies (Cont'd)**

3. For BellSouth® SWA service and BellSouth Directory Assistance Access service, usage sensitive rate elements no credit shall be allowed for an interruption of less than twenty-four hours. The customer shall be credited for an interruption of twenty-four hours or more at the rate applicable for the service involved, for each period of twenty-four hours or major fraction thereof that the interruption continues. In the case of service billed based upon actual usage, no credit allowance is applicable.
4. The credit allowance(s) for an interruption or for a series of interruptions shall not exceed
 - a. the sum of the monthly rates or
 - b. the assumed minutes of use charge for the service interrupted in any one monthly billing period.
5. For certain Special Access (a.k.a. BellSouth® SPA) services (Wideband Digital, WD1-3; Digital Data Access (a.k.a. BellSouth® SPA DS0 Digital Data), DA1-4; and High Capacity (a.k.a. BellSouth® SPA High Capacity), HC1), any period during which the error performance is below that specified for the service will be considered as an interruption.
6. Service interruptions for Specialized Service or Arrangements provided under the provisions of Section E12. *of this Tariff* shall be administered in the same manner as those set forth in E2.4.4. unless other regulations are specified with the Individual Case Basis filing.
7. For the channels used with BellSouth Managed Shared Ring service, failure by the Company to meet the performance guarantee described in E7.5.1 of this Tariff will prompt the credit described in that Section. The combined total of the credit allowance during a month for failure to meet the performance guarantee in E7.5.1 *of this Tariff* for BellSouth® Managed Shared Ring in Section 6.7.21 of Tariff FCC No. 1 of this intrastate Tariff, as applicable, and the credit for service interruption contained in this section shall not exceed the monthly rate for the portion of the service affected. (D)
8. For BellSouth® Wavelength service, a credit for a service interruption of thirty minutes or more per occasion shall be 100 percent of the monthly charges for the BellSouth® Wavelength service. A customer must report the outage in order to receive service outage credit. The total credit received in any month shall not exceed the monthly rate for the service. (D)

C. When A Credit Allowance Does Not Apply

No credit allowance will be made for:

1. Interruptions caused by the negligence of the customer.
2. Interruptions of a service due to the failure of equipment or systems provided by the customer or others.
3. Interruptions of a service during any period in which the Company is not afforded access to the premises where the service is terminated.

BELLSOUTH
TELECOMMUNICATIONS, INC.
KENTUCKY
ISSUED: February 16, 1990
BY: M. H. Greene, President - KY
Louisville, Kentucky

ACCESS SERVICES TARIFF

PSC KY. TARIFF 2E
First Revised Page 14
Cancels Original Page 14
EFFECTIVE: September 17, 1990

E2. GENERAL REGULATIONS

E2.4 Payment Arrangements And Credit Allowances (Cont'd)

E2.4.4 Credit Allowance For Service Interruptions (Cont'd)

C. When A Credit Allowance Does Not Apply (Cont'd)

4. Interruptions of a service when the customer has released that service to the Company for maintenance purposes, to make rearrangements, or for the implementation of an order for a change in the service during the time that was negotiated with the customer prior to the release of that service. Thereafter, a credit allowance as set forth in B. preceding applies.
5. Interruptions of a service which continue because of the failure of the customer to authorize replacement of any element of special construction, as set forth in Section E14 for Special Construction. The period for which no credit allowance is made begins on the seventh day after the customer receives the Company's written notification of the need for such replacement and ends on the day after receipt by the Company of the customer's written authorization for such replacement.
6. Periods when the customer elects not to release the service for testing and/or repair and continues to use it on an impaired basis.
7. Periods of temporary discontinuance as set forth in E2.2.1.B. preceding.
8. An interruption or a group of interruptions, resulting from a common cause, for amounts less than one dollar.
9. Periods of interruption as set forth in E13.3.1.

D. Use of an Alternative Service Provided by the Company

Should the customer elect to use an alternative service provided by the Company during the period that a service is interrupted, the customer must pay the tariffed rates and charges for the alternative service used.

E. Temporary Surrender of a Service

In certain instances, the customer may be requested by the Company to surrender a service for purposes other than maintenance, testing or activity relating to a service order. If the customer consents, a credit allowance will be granted. The credit allowance will be 1/1440 of the monthly rate for each period of 30 minutes or fraction thereof that the service is surrendered. In no case will the credit allowance exceed the monthly rate for the service surrendered in any one monthly billing period.

E2.4.5 Reserved For Future Use (T)

E2.4.6 Reestablishment Of Service Following Fire, Flood Or Other Occurrence (T)

A. Nonrecurring Charges Do Not Apply

Charges do not apply for the reestablishment of service following a fire, flood or other occurrence attributed to an Act of God provided that: (T)

1. The service is of the same type as was provided prior to the fire, flood or other occurrence.
2. The service is for the same customer.
3. The service is at the same location on the same premises.
4. The reestablishment of service begins within 60 days after Company service is available. (The 60 day period may be extended a reasonable period if the renovation of the original location on the premises affected is not practical within the allotted time period.) (T)

B. Nonrecurring Charges Apply

Nonrecurring Charges apply for establishing service at a different location on the same premises or at a different premises pending reestablishment of service at the original location. (T)

BELLSOUTH
TELECOMMUNICATIONS
KENTUCKY
ISSUED: October 31, 2013
BY: Hood Harris, President
Louisville, Kentucky

ACCESS SERVICES TARIFF

PSC KY. TARIFF 2E
Sixth Revised Page 15
Cancels Fifth Revised Page 15
EFFECTIVE: November 14, 2013

E2. GENERAL REGULATIONS**E2.4 Payment Arrangements And Credit Allowances (Cont'd)****E2.4.7 Title Or Ownership Rights**

- A. The payment of rates and charges by customers for the services offered under the provisions of this Tariff does not assign, confer or transfer title or ownership rights to proposals or facilities developed or utilized, respectively, by the Company in the provision of such services.

E2.4.8 Billing of Access Service Provided By Multiple Companies

The Company will adhere to the standards for billing of access service by multiple companies that are set forth in reference documents Ordering and Billing Forum: Multiple Exchange Carrier Access Billing (MECAB) and Ordering and Billing Forum: Multiple Exchange Carrier Ordering and Design (MECOD).

A. Feature Group A (FGA) Service¹

1. When a Feature Group A (*or LSBSA²*) Switched Access Service is ordered by a customer where one end of the Transport element is in the Company's operating territory and the other end is in another Exchange Telephone Company's operating territory, the Exchange Telephone Company in whose territory *FGA dial-tone office* is located, accept the order. In addition, the Exchange Telephone Company in whose territory the *customer's serving wire center* is located must also receive a copy of the order from the customer. The Exchange Telephone Company that accepts the order will then determine the charges involved, arrange to provide the Access Service ordered and bill the charges in accordance with its Access Service Tariff.

Upon agreement of the Exchange Telephone Companies involved in the provision of FGA service, the dedicated portion of FGA service (i.e., Switched Dedicated Interoffice Channel, Switched Local Channel and Channelization Equipment) will be billed in accordance with the provisions of B. and C. following. For non-dedicated portions of FGA service, including the Interconnection charge, the rates of the billing Company will apply.

(DELETED)

B. Single Bill Arrangements**1. General**

If agreed to by the Exchange Telephone Companies involved in the provision of the service, a single bill *arrangement* will be *provided* for *FGB¹, FGD and the dedicated portions of* FGA. In the event that the Exchange Telephone Companies involved agree to change from one billing arrangement to another, the customer will be notified at least 30 days prior to the effective date of such change. (D)

Note 1: Except where indicated herein, references to Feature Groups will also include the applicable Basic Serving Arrangement (BSA) as detailed in the matrix in Section 6.1.3 of Tariff FCC No. 1 (e.g., the term FGA represents both FGA and Line Side Basic Service Arrangement (LSBSA)).

Note 2: Where LSBSA is provisioned with a DNAL E2.4.8 shall also apply to the DNAL.

BELLSOUTH
TELECOMMUNICATIONS
KENTUCKY
ISSUED: October 31, 2013
BY: Hood Harris, President
Louisville, Kentucky

ACCESS SERVICES TARIFF

PSC KY. TARIFF 2E
Fifth Revised Page 15.1
Cancels Fourth Revised Page 15.1
EFFECTIVE: November 14, 2013

E2. GENERAL REGULATIONS**E2.4 Payment Arrangements And Credit Allowances (Cont'd)****E2.4.8 Billing of Access Service Provided by Multiple Companies (Cont'd)****B. Single Bill Arrangements (Cont'd)**

2. Ordering

The customer shall place its access service request with each Exchange Telephone Company involved in the provision of the service.

3. Rating and Billing of Service

The billing company will be as agreed to by the Exchange Telephone Companies involved in the provision of the service. The single bill arrangement may be provided under the following single bill alternatives if agreed to by such companies.

- a. The billing company will bill and collect all appropriate charges in accordance with the regulations, rates and charges in its Access Services Tariff, or
- b. The billing company will bill and collect all appropriate charges in accordance with the rates and charges in its access tariff, for the portion of the service it provides, and in accordance with the rates and charges of the access tariffs of the other Exchange Telephone Companies involved, for the portion of the service which they provide. ***The Interconnection Charge of the end office Telephone Company will apply.*** The bill will separately identify each company's rates and charges, or
- c. The billing company will bill and collect all appropriate charges in accordance with the rates and charges in the access tariffs of the other involved Exchange Telephone Companies, as forwarded to it by such companies for the portion of the service they provide, and in accordance with the rates and charges in its own access tariff for the portion of the service it provides. ***The Interconnection Charge of the end office Telephone Company will apply.*** The bill will separately identify each company's rates and charges.

For b. and c. preceding, the charges billed for the portion of service provided by this Company are determined as set forth in C.3.a., b. and c. following. For nonrecurring charges, one hundred percent of this Company's charge shall apply.

C. Multiple Bill Arrangements

1. General

Separate bills will be rendered by the Exchange Telephone Companies for ***FGB¹, FGD and the dedicated portions of FGA*** Access Service if the administration of a single bill arrangement, as set forth in E2.4.8.B., is not agreed upon by the companies involved. In the event that the Exchange Telephone Companies involved agree to change from one billing arrangement to another, the customer will be notified at least 30 days prior to the effective date of such change. (D)

2. Ordering

The customer shall place its access service request with each Exchange Telephone Company involved in the provision of the service.

Note 1: Except where indicated herein, references to Feature Groups will also include the applicable Basic Serving Arrangement (BSA) as detailed in the matrix in Section 6.1.3 of Tariff FCC No. 1 (e.g., the term FGA represents both FGA and Line Side Basic Service Arrangement (LSBSA)).

BELLSOUTH
TELECOMMUNICATIONS
KENTUCKY
ISSUED: June 17, 2013
BY: Tony Taylor, Executive Director
Louisville, Kentucky

ACCESS SERVICES TARIFF

PSC KY. TARIFF 2E
Tenth Revised Page 16
Cancels Ninth Revised Page 16
EFFECTIVE: July 2, 2013

E2. GENERAL REGULATIONS**E2.4 Payment Arrangements And Credit Allowances (Cont'd)****E2.4.8 Billing of Access Service Provided by Multiple Companies (Cont'd)****C. Multiple Bill Arrangements (Cont'd)****3. Rating and Billing of Service**

Each company will provide its portion of the Access Service based on the regulations, rates and charges contained in its Access Services Tariff, subject to the following rules, as appropriate:

- a. The charges billed by this Company for mileage sensitive rate elements, e.g., BellSouth SWA Transport, Special Access (a.k.a. BellSouth SPA) service Interoffice Channel or BellSouth Directory Assistance Access Transport, are determined as follows:

- (1) The total mileage for the service is computed using the V&H Coordinate Method set forth in Section E10.
- (2) A billing factor is determined from the NATIONAL EXCHANGE CARRIER ASSOCIATION, INC. TARIFF F.C.C. NO. 4 directly.¹
- (3) This Company's rates and charges are then multiplied by the appropriate quantity(ies) and the billing factor to obtain the charges for this Company.

An example of this methodology is shown in 4. following.

- b. The application of nondistance sensitive rate elements varies according to the rate structure and the location of the facilities involved:

- (1) When rates and charges are listed on a per point of termination basis, this Company's rates will be billed for the termination(s) within this Company's operating territory.
- (2) When rates and charges are listed on a per unit basis (e.g., central office bridging or channelization), this Company's rates and charges will apply for units located in this Company's operating territory. For switched access common transport between a Company access tandem and an end office of another company, 50% of this company's Common Transport DS3 to DS1 Multiplexer rate, as set forth in Section 6.8.1(B) of Tariff FCC No. 1, and this company's Directory Transport DS3 to DS1 Multiplexer rate, as set forth in Section E9.5.3(A)(2)(g) shall apply. (C)
- (3) When rates and charges are developed on an individual case basis, such rates will be developed for the portion of the service provided by this Company. (C)
- (4) When rates and charges are listed on a per service basis, this Company's rates and charges are allocated based upon the ratio of points on the access circuit that this company owns, in relation to the total number of points on the circuit.
- (5) For Special Access (a.k.a. BellSouth SPA) service, Interoffice Channel fixed rates, fifty percent of the Company's rate will apply for each end of the Interoffice Channel that this Company provides.

For example:

If the Interoffice Channel fixed rate is \$11.80, and this Company provides only one end of the Interoffice Channel, the rate would be fifty percent of \$11.80, or \$5.90.

If this Company does not provide either end of the Interoffice Channel, this Company's Interoffice Channel fixed rate shall not apply.

- (6) For Switched Interoffice Channel Facility Termination rates, fifty percent of this Company's rate will apply for each end of the Switched Interoffice Channel that this Company provides.

Note 1: See Tariff Addendum, Section 2 (FCC #4, sec 80A) or Section 3 (FCC #4, sec 80B).

BELLSOUTH
 TELECOMMUNICATIONS
 KENTUCKY
 ISSUED: June 17, 2013
 BY: Tony Taylor, Executive Director
 Louisville, Kentucky

ACCESS SERVICES TARIFF

PSC KY. TARIFF 2E
 Third Revised Page 16.1
 Cancels Second Revised Page 16.1
 EFFECTIVE: July 2, 2013

E2. GENERAL REGULATIONS**E2.4 Payment Arrangements And Credit Allowances (Cont'd)****E2.4.8 Billing of Access Service Provided by Multiple Companies (Cont'd)****C. Multiple Bill Arrangements (Cont'd)****3. Rating and Billing of Service (Cont'd)****b. (Cont'd)****(6) (Cont'd)**

For example:

If the BellSouth SWA Dedicated Interoffice Channel Facility Termination rate is \$15.00, and this Company provides only one end of this BellSouth SWA Dedicated Interoffice Channel, the rate would be fifty percent of \$15.00, or \$7.50.

If this Company does not provide either end of the Switched Interoffice Channel, this Company's Switched Interoffice Channel Facility Termination rate shall not apply.

- c. For nonrecurring charges, one-hundred percent of this Company's charge shall apply; *provided, however, that for installation charges pursuant to Section 6.8.1 (E) of Tariff FCC No. 1, only fifty percent of this Company's installation charges will apply where, for trunk installations this Company owns neither the involved end office or access tandem, or for line side installations this Company does not own the Feature Group A dial tone office.* (C)

BELLSOUTH
TELECOMMUNICATIONS, INC.
KENTUCKY
ISSUED: October 22, 1993
BY: M. H. Greene, President - KY
Louisville, Kentucky

ACCESS SERVICES TARIFF

PSC KY. TARIFF 2E
Fourth Revised Page 17
Cancels Third Revised Page 17
EFFECTIVE: February 1, 1994

E2. GENERAL REGULATIONS

E2.4 Payment Arrangements And Credit Allowances (Cont'd)

E2.4.8 Billing of Access Service Provided by Multiple Companies (Cont'd)

C. Multiple Bill Arrangements (Cont'd)

4. Multiple Bill Example¹ for Switched Transport Rate Elements

- a. Assume **Switched Dedicated/Common Transport** is ordered to an End Office in the operating territory of Company A. The **customer** premises is located in the operating territory of Company B.

- (1) Switched Dedicated Transport

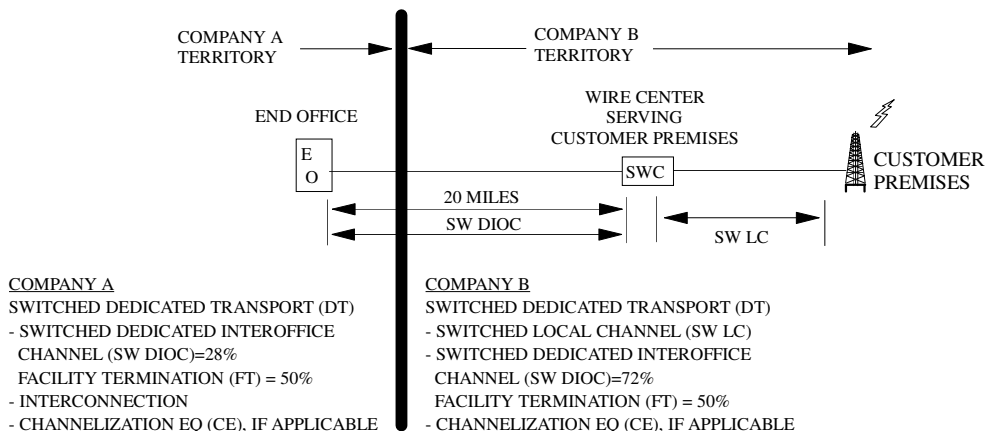

Assume 20 Miles of Switched Dedicated Transport (DT); Assume 8,000 minutes of use; Assume billing factor from NECA No. 4 of 28% for Company A and 72% for Company B.

COMPANY A - DT = \$1.00 per mile
FT = \$25.00 per month
INTERC = \$.002 per mou

DT 20 mi x \$1.00 x 28% = \$ 5.60
FT \$25.00 x 50% = \$12.50
INTERC. \$.002 x 8,000 mou = \$16.00

Note 1: Rates used in each example are for example purposes only.

BELLSOUTH
 TELECOMMUNICATIONS, INC.
 KENTUCKY
 ISSUED: October 22, 1993
 BY: M. H. Greene, President - KY
 Louisville, Kentucky

ACCESS SERVICES TARIFF

PSC KY. TARIFF 2E
 Original Page 17.1

EFFECTIVE: February 1, 1994

E2. GENERAL REGULATIONS

E2.4 Payment Arrangements And Credit Allowances (Cont'd)

E2.4.8 Billing of Access Service Provided by Multiple Companies (Cont'd)

C. Multiple Bill Arrangements (Cont'd)

4. Multiple Bill Example¹ for Switched Transport Rate Elements (Cont'd)

a. (Cont'd)

COMPANY A SWITCHED TRANSPORT = \$34.10

Company B -

FT = \$15.00 per month
SWLC = \$10.00 per month

DT = \$.50 per mile

SWLC = \$ 10.00
FT \$15.00 x 50% = \$ 7.50
DT 20 mi x \$.50 x 72% = \$ 7.20

COMPANY B SWITCHED TRANSPORT = \$24.70

Note 1: Rates used in each example are for example purposes only.

(T)
 (C)
 (C)
 (C)
 (C)
 (C)
 (C)
 (C)
 (C)
 (C)
 (N)

BELLSOUTH
 TELECOMMUNICATIONS, INC.
 KENTUCKY
 ISSUED: July 31, 1998
 BY: E.C. Roberts, Jr., President - KY
 Louisville, Kentucky

ACCESS SERVICES TARIFF

PSC KY. TARIFF 2E
 First Revised Page 17.2
 Cancels Original Page 17.2
 EFFECTIVE: August 1, 1998

E2. GENERAL REGULATIONS

E2.4 Payment Arrangements And Credit Allowances (Cont'd)

E2.4.8 Billing of Access Service Provided by Multiple Companies (Cont'd)

C. Multiple Bill Arrangements (Cont'd)

4. Multiple Bill Example¹ for Switched Transport Rate Elements (Cont'd)

a. (Cont'd)

(2) Switched Common Transport

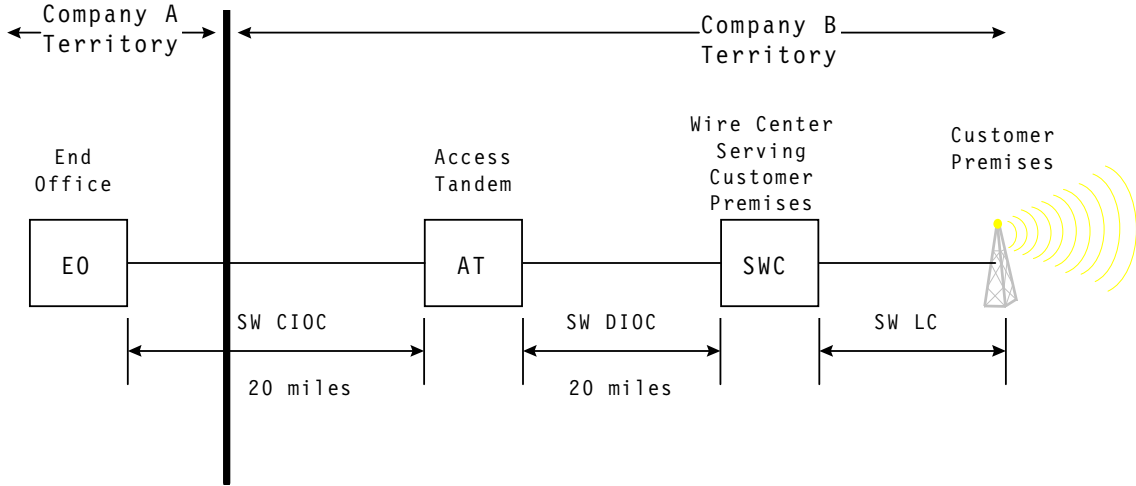

Company A
 Switched Common Transport (CT)
 -Switched Common Interoffice Channel (SW CIOC) = 28%
 -Facility Termination (FT) = 50%
 Interconnection

Company B
 Switched Local Channel (SW LC)
 Switched Common Transport (CT)
 -Sw'd Common Interoffice Ch (SW CIOC) = 72%
 -Facility Termination = 50%
 Switched Dedicated Interoffice Ch (SW DIOC)
 -Sw'd Ded'd Interoffice Ch (SW DIOC) = 100%
 -Facility Termination = 100%
 Access Tandem Switching (AT SW)
 Channelization EQ (CE), if applicable

Assume 20 miles of Switched Common Transport (CT); **20 miles of Switched Dedicated Transport (DT)**; and 8,000 minutes of use. **Further**, assume a billing factor from NECA 4 of 28% for Company A and 72% for Company B.

COMPANY A - CT = \$.0001 per mou/per mile
 CT FT = \$.0001 per mou
 INTERC. = \$.002 per mou

INTERC.	\$.002 x 8,000 mou	= \$16.00
CT	20 mi x \$.0001 x 8,000 mou x 28%	= \$ 4.48
CT FT	\$.0001 x 8,000 mou x 50%	= \$.40

COMPANY A SWITCHED TRANSPORT = \$20.88

Note 1: Rates used in each example are for example purposes only, and do not include multiplexing, tandem trunk ports and end office trunk ports.

BELLSOUTH
 TELECOMMUNICATIONS, INC.
 KENTUCKY
 ISSUED: July 31, 1998
 BY: E.C. Roberts, Jr., President - KY
 Louisville, Kentucky

ACCESS SERVICES TARIFF

PSC KY. TARIFF 2E
 First Revised Page 17.3
 Cancels Original Page 17.3
 EFFECTIVE: August 1, 1998

E2. GENERAL REGULATIONS

E2.4 Payment Arrangements And Credit Allowances (Cont'd)

E2.4.8 Billing of Access Service Provided by Multiple Companies (Cont'd)

C. Multiple Bill Arrangements (Cont'd)

4. Multiple Bill Example¹ for Switched Transport Rate Elements (Cont'd)

a. (Cont'd)

COMPANY B - CT		= \$.0003 per mou/per mile	
CT FT		= \$.0001 per mou	(C)
AT Switching		= \$.00005 per mou	
SWLC		= \$10.00	
DT		= \$2.00 per mile	(N)
DT FT		= \$30.00 per month	(N)
SWLC		= \$10.00	
AT SW	\$\$.00005 x \$8.000 mou	= \$.40	
CT	20 mi. x \$.0001 x 8.000 mou x 72%	= \$11.52	
CT FT	\$.0001 x 8.000 mou x 50%	= \$.40	(C)
DT	20 mi. x \$ 2.00	= \$40.00	(N)
DT FT		= \$30.00	(N)
COMPANY B SWITCHED TRANSPORT		= \$ 92.32	(C)

Note 1: Rates used in each example are for example purposes only *and do not include multiplexing, tandem trunk ports and end office trunk ports* (C)

BELLSOUTH
TELECOMMUNICATIONS
KENTUCKY
ISSUED: March 1, 2024
By: Tricia Conway Tariff Administrator

ACCESS SERVICES TARIFF

PSC KY. TARIFF 2E
Seventh Revised Page 18
Cancels Sixth Revised Page 18
EFFECTIVE: March 17, 2024

E2. GENERAL REGULATIONS**E2.4 Payment Arrangements And Credit Allowances (Cont'd)****E2.4.9 Optional Payment Plan****A. Channel Services Payment Plan****1. General**

- a. The regulations specified herein are applicable to specific facilities as indicated in the appropriate sections of this Tariff for channel services.
- b. Facilities furnished under the Channel Services Payment Plan (CSPP) are subject to all general regulations applicable to the provision of service by the Company as stated elsewhere in this Tariff except as noted herein.
- c. The CSPP is a payment plan which allows customers to pay fixed rates for channel equipment and/or facilities over variable contractual payment periods. A specific monthly rate applies for the duration of each period as follows or as specified otherwise in this Tariff.
 - (1) 36 month Term Payment Plan - payment periods may be selected from 24 months to 48 months in length, at 36 month rates and charges.^{1, 2, 3}
 - (2) 60 month Term Payment Plan - payment periods may be selected from 49 months to 72 months in length, at 60 month rates and charges.^{1, 2}
 - (3) 84 month Term Payment Plan - payment periods may be selected from 73 months to 96 months in length, at 84 month rates and charges.^{1, 2}
- d. When the customer extends service beyond a 96 month² service period, the 84 month² Term Payment Plan (or the longest available tariffed service period) rates will apply.
- e. When the customer orders service to be provided under a CSPP arrangement, the customer must designate to the Company the payment plan and the service period desired, e.g. 84 month² Term Payment Plan and 96 months².

(C)

2. Application of Rates and Charges

- a. Rates stabilized under a CSPP arrangement are exempt from Company-initiated increases, however, decreases for any rate element will automatically flow through to the customer. Effective with this Tariff, customers under a CSPP arrangement will be billed the lower of their existing CSPP rates or the current CSPP rates for their service arrangement.
- b. In the event that all or any part of a service is disconnected at customer request prior to expiration of any selected payment period of greater than one month's duration, the customer will be required to pay a termination charge as stated in that service's section of this Tariff.
- c. When customers renew or change the length of their payment period, the rates applicable for the new period are those currently in effect at the time of the renewal or change in the length of the payment period.
- d. Recurring rates and nonrecurring charges apply according to the appropriate schedules for services offered as associated items to Channel Services, and are filed elsewhere in this Tariff.
- e. Customer requests for inside moves of service will not affect the contract period.
- f. A change in jurisdiction will not constitute a disconnect of service provided the new CSPP arrangement is a minimum 24 month^{2, 3} service period or equals/exceeds the remaining service period, whichever is greater, provided the new CSPP arrangement is for the same customer at the same location for the same capacity service.

(C)

Note 1: Effective March 23, 2019, Customers may not: (1) Establish CSPPs for Digital Data Access Service, Derived Data Channel Service, and FlexServ Service, (2) Establish CSPPs greater than 36 months for High Capacity Service, and (3) Convert or renew CSPPs for Digital Data Access Service, Derived Data Channel Service, FlexServ Service and High Capacity Service.

Note 2: Effective November 1, 2022, customers may not establish new term plans of greater than 24 months for High Capacity Service Channel Service Payment Plans.

Note 3: Effective March 17, 2024, customers may not establish new term plans of greater than month-to-month for High Capacity Service Channel Service Payment Plans.

(N)

BELLSOUTH
TELECOMMUNICATIONS
KENTUCKY
ISSUED: March 1, 2024
By: Tricia Conway Tariff Administrator

ACCESS SERVICES TARIFF

PSC KY. TARIFF 2E
Seventh Revised Page 18.1
Cancels Sixth Revised Page 18.1
EFFECTIVE: March 17, 2024

E2. GENERAL REGULATIONS**E2.4 Payment Arrangements And Credit Allowances (Cont'd)****E2.4.9 Optional Payment Plan (Cont'd)****A. Channel Services Payment Plan (Cont'd)****3. Additions**

- a. Additions of services or rate elements for activating spare or unused capacities of a service under a CSPP arrangement will be considered part of the existing CSPP arrangement.
- b. Additions of services or rate elements, i.e. new local channels, interoffice channels, etc., other than for activating spare or unused capacities, must be under a new CSPP arrangement at rates and charges as specified in 2. preceding.
- c. Termination charges for premature disconnection of added contractual services will apply as set forth under Disconnects as stated in 4. following.
- d. Additions under CSPP are exempt from Company initiated rate changes for all payment periods longer than one month. However, decreases for any rate element will automatically flow through to the customer.
- e. Nonrecurring charges, as specified in this Tariff, will apply to the added channel services.

4. Disconnects

- a. When a service or rate element, included under a CSPP arrangement, is disconnected prior to expiration of the selected service period, termination liability charges apply as set forth in the rate regulations in this Tariff for such service. Remaining services or rate elements will not be affected by such disconnections.
- b. When a tariffed service under a CSPP arrangement is disconnected prior to the expiration of a selected service period as a result of a change of Tariff jurisdiction and/or a customer requested change to a higher order of a separately tariffed service, termination liability charges will not apply when:

- the service period of the new CSPP arrangement^{1, 2} for the higher order of service is a minimum 24 month service period or equals/exceeds the remaining service period of the disconnected arrangement, whichever is greater, and (C)
- the service orders to install the new higher order of service and disconnect the old service are related together and there is no lapse in service between installation of the higher order of service and disconnection of the existing service, and
- the service orders are for the same customer at the same location

For the purposes of determining a higher order of service, the following ranking will be used (Analog Voice Grade (a.k.a. BellSouth SPA DS0 VG) = lowest, Channels for use with BellSouth Managed Shared Ring service = Highest):

- Analog Voice Grade (a.k.a. BellSouth SPA DS0 VG) Services
- DS0 (a.k.a. BellSouth SPA DS0 VG) Services
- DS1 High Capacity (a.k.a. BellSouth SPA DS1) Service^{1, 2} (C)
- Channels for use with BellSouth Managed Ring service

5. Moves of Equipment

- a. The appropriate nonrecurring charges for inside moves for items associated with channel services as specified in this and other Tariffs are applicable. This type movement will not affect the contract period.
- b. Customer requests for moves of services(s) under CSPP, other than inside moves, will be subject to the conditions stated in 11. following.

Note 1: Effective November 1, 2022, customers may not establish new term plans of greater than 24 months for High Capacity Service Channel Service Payment Plans.

Note 2: Effective March 17, 2024, customers may not establish new term plans of greater than month-to-month for High Capacity Service Channel Service Payment Plans. (N)

BELLSOUTH
TELECOMMUNICATIONS, INC.
KENTUCKY

ACCESS SERVICES TARIFF

PSC KY. TARIFF 2E
Original Page 18.1.1

ISSUED: August 26, 1994
BY: M. H. Greene, President - KY
Louisville, Kentucky

EFFECTIVE: September 26, 1994

E2. GENERAL REGULATIONS

E2.4 Payment Arrangements And Credit Allowances (Cont'd)

E2.4.9 Optional Payment Plan (Cont'd)

A. Channel Services Payment Plan (Cont'd)

6. Requests for Changes in Length of Optional Payment Period (M)
 - a. Subsequent to the establishment of a contract with a CSPP period, and prior to the completion of that period, the existing payment period may be replaced by: (M)
 - (1) A currently offered payment period at the current rates, with a length equal to or longer than the time remaining in the existing service agreement, subject to the following conditions: (M)
 - No credit will be given for payments made during the formerly selected period. (M)
 - The new payment period begins with the *new CSPP effective* date. (M)
 - No termination charge applies for the remaining portion of the former payment period. (M)
 - Nonrecurring charges will not be reapplied. (M)
 - (2) A currently offered payment period at the current rates, with a length shorter than the time remaining in the existing service agreement, subject to the following conditions: (M)
 - No credit will be given for payments made during the formerly selected period. (M)
 - The new payment period begins with the *new CSPP effective date*. (M)
 - A termination charge applies for the remaining portion of the former payment period. (M)
 - Nonrecurring charges will not be reapplied. (M)

Material appearing on this page previously appeared on page(s) 18.1 of this section

BELLSOUTH
TELECOMMUNICATIONS
KENTUCKY
ISSUED: March 1, 2024
By: Tricia Conway Tariff Administrator

ACCESS SERVICES TARIFF

PSC KY. TARIFF 2E
Eighth Revised Page 18.2
Cancels Seventh Revised Page 18.2
EFFECTIVE: March 17, 2024

E2. GENERAL REGULATIONS**E2.4 Payment Arrangements And Credit Allowances (Cont'd)****E2.4.9 Optional Payment Plan (Cont'd)****A. Channel Services Payment Plan (Cont'd)****7. Renewal Options**

- a. The customer has the following renewal^{1, 2, 3} options: (C)
- (1) Prior to completion of the current payment period, any period available under the CSPP may be selected at the rates in effect for new customers at the time of the renewal.^{1, 2, 3} The customer will be charged the current rate for the newly selected payment period, commencing the day following completion of the prior payment period. (C)
 - (2) Service may be continued on a month-to-month basis at the current rate for the one-month payment period, unless otherwise specified in this Tariff. The customer has no additional service commitment and, consequently, when service is terminated will not be subject to any termination charge. The one-month service will be subject to Company-initiated rate adjustments when approved by the appropriate regulatory authority.
 - (3) If the customer does not elect an additional payment period or does not request discontinuance of service, service will be continued at the monthly rate currently in effect for the month-to-month payment rate, under the terms specified in (2) preceding.
- b. Nonrecurring charges are not applicable for services renewed under the CSPP. Any new services added at the time of renewal will be subject to all appropriate nonrecurring charges.
- c. The Company may discontinue or change any or all renewal options with approval of the appropriate regulatory authority.
- d. When a customer renews a CSPP arrangement, the rates and charges in effect on the first day of service of the renewal will apply.
- e. Recognition of previous service will be given to customers who renew an existing CSPP arrangement, for the same or larger system(s) and all associated rate elements at the same location(s), provided that the length of the new CSPP arrangement is a minimum 24 month service period or equals/exceeds the remaining service period of the original CSPP arrangement, whichever is greater. An example of a larger system is the renewal of an Analog Voice Grade (a.k.a. BellSouth SPA DS0 Digital Data) service with a DS1 High Capacity (a.k.a. BellSouth SPA DS1) service.
- f. Recognition of previous service will be given to month-to-month customers with a service date of January 1, 1994 or later who convert to a CSPP arrangement, provided the minimum service period has been met. For customers whose service date is January 1, 1994 or earlier, recognition will be given for the previous service back to January 1, 1994. For customers whose service date is later than January 1, 1994, recognition for the previous service will be given back to the actual service date.
- g. To determine the appropriate CSPP Payment Plan for the renewed arrangement, recognition of service will consist of the sum of months in service of the completed service arrangement and the sum of the months of the proposed service period of the CSPP arrangement. For example, a CSPP arrangement for a 36-month^{2, 3} service period under the 36 month Term Payment Plan is renewed for 24 months with no changes at the end of the 36 month^{2, 3} period. The sum of months for the completed and proposed service periods would equal 60 months^{2, 3} and would be billed under the 60 month^{2, 3} Term Payment Plan. Another example is a Month-to-Month customer, in service for 15 months, who wishes to convert to a 60-month^{2, 3} CSPP arrangement with no changes. The combined service period of the Month-to-Month arrangement and the CSPP arrangement is equal to 75 months, which would be billed under the 84 month^{2, 3} Term Payment Plan. (C)

Note 1: Effective March 23, 2019, Customers may not: (1) Establish CSPPs for Digital Data Access Service, Derived Data Channel Service, and FlexServ Service, (2) Establish CSPPs greater than 36 months for High Capacity Service, and (3) Convert or renew CSPPs for Digital Data Access Service, Derived Data Channel Service, FlexServ Service and High Capacity Service.

Note 2: Effective November 1, 2022, customers may not establish new term plans of greater than 24 months for High Capacity Service Channel Service Payment Plans.

Note 3: Effective March 17, 2024, customers may not establish new term plans of greater than month-to-month for High Capacity Service Channel Service Payment Plans. (N)

BELLSOUTH
TELECOMMUNICATIONS, INC.
KENTUCKY
ISSUED: August 26, 1994
BY: M. H. Greene, President - KY
Louisville, Kentucky

ACCESS SERVICES TARIFF

PSC KY. TARIFF 2E
Original Page 18.2.0.1

EFFECTIVE: September 26, 1994

E2. GENERAL REGULATIONS

E2.4 Payment Arrangements And Credit Allowances (Cont'd)

E2.4.9 Optional Payment Plan (Cont'd)

A. Channel Services Payment Plan (Cont'd)

8. Transfer of Service (N)
 - a. Service may be transferred to a new customer at the same location upon prior written concurrence by the new customer as specified in this Tariff. This does not constitute a disconnect of service or a discontinuance of an existing CSPP arrangement. The new customer will be subject to all provisions and equipment configurations currently in effect for the previous customer. Regulations concerning transfer of service between subscribers as stated in other sections of this Tariff also apply under CSPP. (N)
9. Prepayment (N)
 - a. For payment periods longer than one month, the customer may prepay the total outstanding recurring monthly rates. The prepayment of monthly rates in no way constitutes a purchase and the Company retains full ownership of all services covered by the prepayment. The following conditions apply: (N)
 - (1) Customers who prepay six months or more will have an allowance applied. The prepayment factor to be used for each month prepaid will be revised periodically by the Company. (N)
 - (2) Monthly rates for all services covered by a single Letter of Election must be prepaid. Monthly rates must be prepaid for services added subsequently and placed on the same Letter of Election (i.e., customer-elected coterminous option) with a prepaid system. (N)
 - (3) Customers who change the length of a prepaid payment period will be credited any unused portion of the prepayment, subject to termination charges as specified in 4. preceding. (N)
 - (4) Customers who prematurely disconnect will have termination charges deducted from the prepaid amount and any balance credited to their bill. (N)
10. Exception to Termination Liability For State, County, and Municipal Governments (N)
 - a. In the event that all or any part of the service is disconnected at customer request prior to expiration of any selected payment period of greater than one month's duration, the customer will be required to pay a termination charge as stated in the service tariffs. The Tariffs provisions concerning termination liability for recurring charges only shall be inapplicable to any state, county or municipal governmental entity when there is in effect, as a result of action by such entity and through a duly constituted legislative, administrative body: (N)
 - (1) a statute; (N)
 - (2) an ordinance; (N)
 - (3) a policy directive; or (N)
 - (4) a constitutional provision (N)

which restricts or prohibits an additional contractual payment for early termination of a contract by any such entity, or agency thereof, due to an unavailability of funding. When service is being provided and funding to the governmental entity for such service becomes unavailable, the governmental entity may cancel the service without additional payment obligation. Provided however, that if the governmental entity cancels the service for any reason other than the unavailability of funds, the termination liability provisions in the Tariff shall apply. (N)

BELLSOUTH
 TELECOMMUNICATIONS
 KENTUCKY
 ISSUED: December 16, 2022
 BY: Cyndi Gallagher, Director – External Affairs

ACCESS SERVICES TARIFF

PSC KY. TARIFF 2E
 Third Revised Page 18.2.0.2
 Cancels Second Revised Page 18.2.0.2
 EFFECTIVE: January 1, 2023

E2. GENERAL REGULATIONS**E2.4 Payment Arrangements And Credit Allowances (Cont'd)****E2.4.9 Optional Payment Plan (Cont'd)****A. Channel Services Payment Plan (Cont'd)****11. Moves of Service(s) under CSPP**

Termination Liability Charges will not apply to customer requests for moves of service under CSPP from one location to another location subject to the following:

- a. The original and new premises locations must be in Company territory within the same state.
- b. The move from the original location to the new location must be completed within thirty days of the original premises disconnect date.
- c. No lapse in billing will occur for moves of service under CSPP.
- d. Orders to disconnect the existing service and reestablish it at the new location must be related.
- e. Any local channels, interoffice channels, and/or optional features and functions from the original location that are not reestablished at the new location will be subject to applicable Termination Liability charges.
- f. Any additions made at the new location will be treated as coterminous additions in accordance with 3. preceding.
- g. All regulations and charges for changes made to the service coincident to the move shall apply.
- h. All appropriate nonrecurring charges for moves of service under CSPP as specified elsewhere in this Tariff will apply.
- i. Moves of service that involve a change of jurisdiction, e.g., intraLATA to intrastate, intrastate to interstate, etc. will not be treated as a disconnect of service with regard to Termination Liability charge application. The customer must subscribe to a payment arrangement offered in the appropriate tariff which is a minimum 24-month service period or equals/exceeds the remaining contract period, whichever is greater.

B. *Reserved For Future Use*

(T)
 (D)

BELLSOUTH
TELECOMMUNICATIONS
KENTUCKY
ISSUED: December 16, 2022
BY: Cyndi Gallagher, Director – External Affairs

ACCESS SERVICES TARIFF

PSC KY. TARIFF 2E
Third Revised Page 18.2.0.3
Cancels Second Revised Page 18.2.0.3
EFFECTIVE: January 1, 2023

E2. GENERAL REGULATIONS

E2.4 Payment Arrangements And Credit Allowances (Cont'd)

E2.4.9 Optional Payment Plan (Cont'd)

B. *Reserved For Future Use* (Cont'd)

(T)

(D)

BELLSOUTH
TELECOMMUNICATIONS
KENTUCKY

ACCESS SERVICES TARIFF

PSC KY. TARIFF 2E
First Revised Page 18.2.0.3.1
Cancels Original Page 18.2.0.3.1
EFFECTIVE: January 1, 2023

ISSUED: December 16, 2022

BY: Cyndi Gallagher, Director – External Affairs

E2. GENERAL REGULATIONS

E2.4 Payment Arrangements And Credit Allowances (Cont'd)

E2.4.9 Optional Payment Plan (Cont'd)

B. *Reserved For Future Use* (Cont'd)

(T)

(D)

BELLSOUTH
TELECOMMUNICATIONS
KENTUCKY

ACCESS SERVICES TARIFF

PSC KY. TARIFF 2E
First Revised Page 18.2.0.4
Cancels Original Page 18.2.0.4
EFFECTIVE: January 1, 2023

ISSUED: December 16, 2022

BY: Cyndi Gallagher, Director – External Affairs

E2. GENERAL REGULATIONS

E2.4 Payment Arrangements And Credit Allowances (Cont'd)

E2.4.9 Optional Payment Plan (Cont'd)

B. *Reserved For Future Use* (Cont'd)

(T)

(D)

BELLSOUTH
TELECOMMUNICATIONS
KENTUCKY

ACCESS SERVICES TARIFF

PSC KY. TARIFF 2E
First Revised Page 18.2.0.5
Cancels Original Page 18.2.0.5
EFFECTIVE: January 1, 2023

ISSUED: December 16, 2022

BY: Cyndi Gallagher, Director – External Affairs

E2. GENERAL REGULATIONS

E2.4 Payment Arrangements And Credit Allowances (Cont'd)

E2.4.9 Optional Payment Plan (Cont'd)

B. *Reserved For Future Use* (Cont'd)

(T)

(D)

BELLSOUTH
 TELECOMMUNICATIONS
 KENTUCKY
 ISSUED: June 17, 2013
 BY: Tony Taylor, Executive Director
 Louisville, Kentucky

ACCESS SERVICES TARIFF

PSC KY. TARIFF 2E
 Third Revised Page 18.2.0.6
 Cancels Second Revised Page 18.2.0.6
 EFFECTIVE: July 2, 2013

E2. GENERAL REGULATIONS**E2.4 Payment Arrangements and Credit Allowances (Cont'd)****E2.4.9 Optional Payment Plan (Cont'd)**

C. Transport Payment Plan (TPP)

1. General

- a. The regulations and terms specified herein are applicable only to BellSouth Dedicated Ring, SMARTRing service (a.k.a. BellSouth Dedicated Ring), **BellSouth Metro Ethernet service** and/or BellSouth Wavelength service access services as indicated in the rate regulations in Section 6 of Tariff FCC No. 1 and Sections E7. and E29. of this intrastate Tariff. (C)
- b. The TPP allows customers to pay stabilized monthly rates for fixed service periods selected by the customer. The three payment plans offered are as follows:
 - (1) Payment Plan A, service periods may be selected from 12 months to 36 months in length.
 - (2) Payment Plan B, service periods may be selected from 37 months to 60 months in length.
 - (3) Payment Plan C, service periods may be selected from 61 months to 96 months in length.
- c. For conversions to the TPP arrangement, the number of months under the TPP arrangement must equal or exceed the number of months remaining under the CSPP arrangement.
- d. Termination liability charges and nonrecurring charges will not apply when a CSPP customer converts to a TPP arrangement.
- e. When the customer renews a TPP arrangement and the sum of months in service added to the new contract period is greater than the number of months for which the service is available under a TPP, the current Payment Plan C rates will apply.
- f. When the customer orders service to be provided under a TPP arrangement, the customer must designate to the Company the payment plan desired.
- g. Rates stabilized under a TPP arrangement are exempt from Company initiated increases, however, decreases for any rate element will automatically be reflected in the rates charged to the customer.
- h. Conversions of BellSouth Wavelength service, LightGate service (a.k.a. BellSouth SPA Point to Point Network), BellSouth Dedicated Ring and/or SMARTRing service (a.k.a. BellSouth Dedicated Ring) TPP arrangements to a higher order of CSPP service are allowed.

2. Application of Rates

- a. The stabilized monthly recurring rates as set forth in Section 6 of Tariff FCC No. 1 and Sections E7. and E29. of this intrastate Tariff are set as of the Application Date for BellSouth Dedicated Ring, SMARTRing service (a.k.a. BellSouth Dedicated Ring), **BellSouth Metro Ethernet service** and/or BellSouth Wavelength service provided that the actual service date does not exceed the latter of the following: (C)
 - (1) the Service Date under a standard service interval, or
 - (2) the earliest date by which service can be made available to the customer by the Company.
- b. If the customer desires a service date later than as provided in a. preceding, the stabilized monthly recurring rates in effect on the service date are applicable.

Page reformatted pursuant to 807 KAR 5:011—Tariffs, Section 3 (4).

BELLSOUTH
 TELECOMMUNICATIONS
 KENTUCKY
 ISSUED: June 17, 2013
 BY: Tony Taylor, Executive Director
 Louisville, Kentucky

ACCESS SERVICES TARIFF

PSC KY. TARIFF 2E
 Original Page 18.2.0.6.1

EFFECTIVE: July 2, 2013

E2. GENERAL REGULATIONS**E2.4 Payment Arrangements and Credit Allowances (Cont'd)****E2.4.9 Optional Payment Plan (Cont'd)****C. Transport Payment Plan (TPP) (Cont'd)****3. Additions**

- a. Additions of services or rate elements, to existing BellSouth Dedicated Ring and/or SMARTRing service (a.k.a. BellSouth Dedicated Ring) systems, to activate spare or unused capacities, must be activated under the same rate plan as the existing TPP arrangement. BellSouth Dedicated Ring and/or SMARTRing service (a.k.a. BellSouth Dedicated Ring) channel interfaces must be activated as set forth in Section 6 Tariff FCC No. 1 and Section E7. of this intrastate Tariff.

(M)
 (C)
 (C)

4. Disconnects

- a. Except as provided in b. through f. following, when a BellSouth Wavelength service, BellSouth Dedicated Ring, *BellSouth Metro Ethernet service* and/or SMARTRing service (a.k.a. BellSouth Dedicated Ring) rate element is disconnected prior to being in service for a 12-month period, (e.g., the minimum term for a Plan A TPP), the termination liability charge will be derived by multiplying the difference in rates between the current month-to-month rate and the rate for the TPP arrangement selected. For example, a customer subscribes to a TPP for 24 months (Plan A) and terminates service after 10 months. The termination liability charge will be applied by multiplying the number of months in service (10) by the difference between the month-to-month and Plan A monthly rates. With the exception of Renewal Options in 7. following, a four month minimum service period for BellSouth Wavelength service, BellSouth Dedicated Ring, *BellSouth Metro Ethernet service* and/or SMARTRing service (a.k.a. BellSouth Dedicated Ring) TPP customers will be applicable and all month-to-month regulations will be applicable.

(M)

Page reformatted pursuant to 807 KAR 5:011—Tariffs, Section 3 (4).

BELLSOUTH
TELECOMMUNICATIONS
KENTUCKY
ISSUED: October 30, 2014
BY: Hood Harris, President
Louisville, Kentucky

ACCESS SERVICES TARIFF

PSC KY. TARIFF 2E
Fourth Revised Page 18.2.0.7
Cancels Third Revised Page 18.2.0.7
EFFECTIVE: November 14, 2014

E2. GENERAL REGULATIONS**E2.4 Payment Arrangements and Credit Allowances (Cont'd)****E2.4.9 Optional Payment Plan (Cont'd)**

C. Transport Payment Plan (Cont'd)

4. Disconnects (Cont'd)

a. (Cont'd)

When a BellSouth Wavelength service, BellSouth Dedicated Ring, *BellSouth Metro Ethernet service* or SMARTRing service (a.k.a. BellSouth Dedicated Ring) TPP customer disconnects a rate element prior to the 12 month TPP minimum, all current month-to-month nonrecurring charges associated with the BellSouth Wavelength service rate elements, BellSouth Dedicated Ring, *BellSouth Metro Ethernet service* or the SMARTRing service (a.k.a. BellSouth Dedicated Ring) ring level rate elements will apply.

BellSouth Dedicated Ring and SMARTRing service (a.k.a. BellSouth Dedicated Ring) service ring level rate elements are defined as following: Local Channel, Interoffice Channel, Internodal Channel, Alternate Central Office Channel, Customer Node and Central Office Node. BellSouth Wavelength service rate elements are defined as Wavelength Channels.

- b. Except as provided in c. through f. following, when a BellSouth Wavelength service, BellSouth Dedicated Ring, *BellSouth Metro Ethernet service* or SMARTRing service (a.k.a. BellSouth Dedicated Ring) TPP customer disconnects services or rate elements prior to the minimum number of months for the plan period selected, termination liability charges will apply. The termination liability charge will be derived at the time of disconnection by taking the difference between the rate for the TPP period for which the customer subscribed, and the rate for the TPP period that the customer's completed service would otherwise qualify, and multiplying the difference by the number of months service the customer completed under a TPP. For example, a customer subscribes to a TPP for 73 months (Plan C) and terminates service after 20 months (Plan A). The termination liability charge will be applied by multiplying the number of months in service (20) by the difference between the Plan A and Plan C monthly rates. When a BellSouth Wavelength service, BellSouth Dedicated Ring, *BellSouth Metro Ethernet service* or SMARTRing service (a.k.a. BellSouth Dedicated Ring) customer disconnects service after the minimum number of months for the TPP arrangement selected but prior to the actual expiration date of the TPP arrangement, termination liability charges do not apply.
- c. When a TPP arrangement is disconnected prior to the expiration of a plan period due to a customer requested change to a higher order of service at the same location, or to expand or upgrade an existing service, termination liability charges will not apply when:
- (1) the customer has completed at least 6 months of the originally selected TPP service period, and
 - (2) the service period of the new arrangement for the new service is equal to or longer than the remaining service period of the disconnected arrangement, and
 - (3) the service orders to install the new service and disconnect the old service are related together and received by the Company at the same time, and there is no lapse in service between installation of the higher order of service and disconnection of the existing service, and
 - (4) the capacity of the new service is equal to or greater than the existing service. For converting LightGate service (a.k.a. BellSouth SPA Point to Point Network) to SMARTPath service DS3 Transport service (a.k.a. BellSouth SPA DS3 Shared Ring), the capacity of the LightGate service (a.k.a. BellSouth SPA Point to Point Network) is considered to be the quantity of DS3s activated on the LightGate service (a.k.a. BellSouth SPA Point to Point Network). *Specific changes of BellSouth Metro Ethernet service that are considered to be the same or higher order of service are set forth in E7.4.32 of this Tariff.*

For the purposes of determining a higher order of service in all payment plans, the following ranking will be used (Analog Voice Grade (a.k.a. BellSouth SPA DS0 VG) service=lowest, SMARTRing service (a.k.a. BellSouth Dedicated Ring)=highest):

- Analog Voice Grade (a.k.a. BellSouth SPA DS0 VG) services
- DS0 (a.k.a. BellSouth SPA DS0 Digital Data) Services
- DS1 (a.k.a. BellSouth SPA DS1) Services
- SMARTPath service (a.k.a. BellSouth SPA DS1 Shared Ring)
- BellSouth Wavelength service
- SMARTRing service (a.k.a. BellSouth Dedicated Ring)/BellSouth Dedicated Ring/ Channels for use with BellSouth Managed Shared service

- d. A termination liability charge will not apply to disconnects of channel interfaces associated with LightGate service (a.k.a. BellSouth SPA Point to Point Network), BellSouth Dedicated Ring and/or SMARTRing services (a.k.a. BellSouth Dedicated Ring).

(D)

BELLSOUTH
TELECOMMUNICATIONS
KENTUCKY
ISSUED: July 2, 2015
BY: Hood Harris, President
Louisville, Kentucky

ACCESS SERVICES TARIFF

PSC KY. TARIFF 2E
Second Revised Page 18.2.0.8
Cancels First Revised Page 18.2.0.8
EFFECTIVE: July 17, 2015

E2. GENERAL REGULATIONS**E2.4 Payment Arrangements and Credit Allowances (Cont'd)****E2.4.9 Optional Payment Plan (Cont'd)**

C. Transport Payment Plan (Cont'd)

4. Disconnects (Cont'd)

- e. Disconnects, moves, or rearrangements involving the removal of the following BellSouth Dedicated Ring and SMARTRing[®] service (a.k.a. BellSouth[®] Dedicated Ring) rate elements, local channel, interoffice channel, customer node and central office node, to allow the placement of additional nodes and channels for existing customers where the total number of nodes does not decrease, will not be subject to termination liability charges.
- f. A change of jurisdiction from interstate to intrastate service constitutes a disconnection of service for which termination charges are applicable. However, if such service continues between the same serving locations, and the customer enters into a new TPP arrangement in the intrastate jurisdiction for the same or larger service capacity and associated rate elements for a service period equal to or greater than the service period remaining under the interstate TPP arrangement, no interstate termination liability charge will be applicable.
- g. Termination liability charges will not apply to any OC-3+ SMARTRing service (a.k.a. BellSouth SPA Dedicated Ring) disconnected on or after July 4, 2015. (N)

5. Moves of Service Under TPP

- a. Moves to a different building will be treated as a discontinuance and start of service and all associated nonrecurring charges will apply as stated in Sections E7.4.5 and E29.1.4, except as provided in c. following. A four month minimum service period must be satisfied for all service rate elements serving the original building location. (T)
- b. Moves of service within the same building will not constitute a disconnection of service for purposes of the application of termination liability charges. Current month-to-month nonrecurring charges specified in Sections E7.4.5 and E29.1.4 are applicable. (T)
- c. Termination Liability Charges will not apply to customer requests for moves of service to a different building subject to the following conditions:
 - (1) The move from the original location to the new location must be completed within thirty days of the original premises disconnect date. For LightGate[®] service systems (a.k.a. BellSouth[®] SPA Point to Point Network), the new customer premises must be served by the same serving wire center as the original location.
 - (2) No lapse in billing will occur for moves of service under a TPP arrangement.
 - (3) Orders to disconnect the existing service and reestablish it at the new location must be related together and received by the Company at the same time.
 - (4) Any additions made at the new location will be handled in accordance with (3) preceding.
 - (5) All regulations and charges for changes made to the service coincident with the move will apply.
 - (6) All appropriate nonrecurring charges for moves of service as specified in Sections E7.4.5 and E29.1.4 will apply. (T)

Any rate elements or quantities for local channels, interoffice channels, *wavelength channels* and/or optional features and functions from the original location that are not reestablished at the new location will be subject to applicable Termination Liability Charges.

6. Requests for Changes in Length of Service Period

- a. Subsequent to the establishment of a TPP arrangement, and prior to the completion of the selected service period for that arrangement, the TPP arrangement may be replaced by a new TPP arrangement at rates and charges in effect on the first day of service under the new TPP arrangement, subject to the following conditions:
 - (1) No credit will be given for payments made under the original TPP arrangement, except for credits allowed under 9.a. following.
 - (2) The service period selected for the new TPP arrangement begins on the new TPP effective date but not later than the expiration date of the TPP being replaced.
 - (3) Nonrecurring charges do not apply for existing services.
 - (4) If the new TPP arrangement has a service period shorter in length than the time remaining under the service period for the existing TPP arrangement, the change to the new TPP arrangement constitutes a disconnection of the existing TPP arrangement for which termination liability charges apply.

BELLSOUTH
TELECOMMUNICATIONS, INC.
KENTUCKY
ISSUED: February 7, 2005
BY: E.C. Roberts, Jr., President - KY
Louisville, Kentucky

ACCESS SERVICES TARIFF

PSC KY. TARIFF 2E
Second Revised Page 18.2.0.9
Cancels First Revised Page 18.2.0.9
EFFECTIVE: March 9, 2005

E2. GENERAL REGULATIONS**E2.4 Payment Arrangements and Credit Allowances (Cont'd)****E2.4.9 Optional Payment Plan (Cont'd)**

C. Transport Payment Plan (Cont'd)

7. Renewal Options

- a. When a service period under an existing CSPP or TPP arrangement is completed, the customer may select a new TPP arrangement at rates and charges in effect on the first day of service under the new TPP arrangement, continue service under the month-to-month rates, or discontinue service with no termination liability charge. If the customer does not elect to either discontinue service or continue service under a new TPP arrangement, service will be continued under month-to-month rates. The TPP customer of record will have a 60-day grace period after which current month-to-month rates will apply. The stabilized monthly recurring rates as set forth in Sections E7. and E29. of this Tariff remain in effect during the 60-day grace period.
- b. Any new services added to a customer's network or changes to existing services at the time of renewal will be subject to all appropriate nonrecurring charges and four month minimum service period requirements.
- c. When a customer renews a TPP arrangement, the rates and charges in effect on the first day of service of the renewal will apply.
- d. To determine the appropriate TPP Payment Plan for the renewed arrangement, recognition of service will consist of the sum of months in service of the completed service arrangement and the sum of months of the proposed service period of the TPP arrangement.
- e. Recognition of previous service will be given to customers who renew an existing TPP arrangement, for the same or larger system(s) and all associated rate elements at the same location(s), provided that the length of the new TPP arrangement is equal to or greater than the remaining service period of the original TPP arrangement. Recognition for satisfying the four month service period will be given for renewals of the same size systems, rings, and all associated rate elements. Conversion to larger systems and rings will incur new four month minimum service requirements.
- f. Recognition of previous service will be given to month-to-month customers who convert to a TPP arrangement, for the same or larger system(s) and all associated rate elements at the same location(s), provided the four month minimum service period for that service has been met.
- g. Recognition of previous service will be given to TPP customers who convert from CSPP arrangements provided the customer is the original customer of record at the time of transfer.
- h. When an existing BellSouth Wavelength service, BellSouth Dedicated Ring, *BellSouth Metro Ethernet service* and/or SMARTRing service (a.k.a. BellSouth SPA Dedicated Ring) customer has completed the selected TPP commitment period and the service reverts to month-to-month service, only the month-to-month service will receive recognition for determining the appropriate TPP arrangement or any subsequent TPP arrangement. (C)

8. Transfer of Service

- a. Service transferred to a new customer at the same location in accordance with E2.1.2 preceding does not constitute a disconnect of service or a discontinuance of an existing TPP arrangement.

9. Prepayment

- a. Upon entering into a TPP arrangement, the customer may prepay the outstanding recurring monthly rates in whole or in part for all rate elements included in the TPP arrangement. The following conditions apply:
 - (1) A prepayment allowance will be applied to the amount prepaid for each given month equal to 0.6666 percent per month compounded monthly for the number of months the payment is advanced.
 - (2) The customer may elect the percentage of the monthly rates to be prepaid, provided however, the same percentage shall apply to all rate elements included in the TPP arrangement for all months remaining in the service period.
 - (3) This same prepayment percentage will apply in the event the customer adds services to an existing TPP arrangement subsequent to the establishment of the service.
 - (4) When a customer who has prepaid recurring monthly rates replaces the existing TPP arrangement with a new TPP arrangement, the customer will be credited with that portion of the prepayment amount, representing a prepayment of the monthly recurring rates remaining in the existing TPP arrangement.
 - (5) Customers who disconnect service and incur termination liability charges, such charges shall be deducted from the unused prepaid balance. The remaining prepaid balance, if any, will be credited to their bill.

BELLSOUTH
 TELECOMMUNICATIONS
 KENTUCKY
 ISSUED: June 17, 2013
 BY: Tony Taylor, Executive Director
 Louisville, Kentucky

ACCESS SERVICES TARIFF

PSC KY. TARIFF 2E
 Ninth Revised Page 18.2.1
 Cancels Eighth Revised Page 18.2.1
 EFFECTIVE: July 2, 2013

E2. GENERAL REGULATIONS**E2.4 Payment Arrangements And Credit Allowances (Cont'd)****E2.4.10 Service Installation Guarantee**

- A. The Company assures that orders for services to which the Service Installation Guarantee applies will be installed and available for customer use no later than the Service Date as specified in E5.2.4.B following. The Service Installation Guarantee is applicable only as specified in Section 6.7.1 of Tariff FCC No. 1 and Section E7.4.1.A of this intrastate Tariff. (C)
- B. The failure of the Company to meet this commitment will result in the credit of an amount equal to the nonrecurring charges associated with the individual service having the missed Service Date being applied to the customer's bill. The credit will include only nonrecurring charges associated with the services specified in Section 6.7.1 of Tariff FCC No. 1 and Section E7.4.1.A of this intrastate Tariff for which nonrecurring charges are applicable. The nonrecurring charges will be credited at the rate at which they were billed. The credit will not be provided if a credit of the same nonrecurring charge for the same service is provided under any other provisions of this Tariff. (C)
- C. Service Installation Guarantees do not apply:
 - 1. when failure to meet the Service Date occurs because of:
 - a. any act or omission, which shall include an accurate and complete service order from this customer, any other customer or any third party, or of any other entity providing a portion of a service,
 - b. labor difficulties, governmental orders, civil commotions, criminal actions against the Company, acts of God, war, or other circumstances beyond the Company's control,
 - c. unavailability of the customer's facilities and/or equipment,
 - 2. to service requiring Special Construction as set forth in Section E14 following,
 - 3. to Specialized Service or Arrangements or Individual Case Basis filings,
 - 4. for jointly provisioned services except as stipulated *in* 5 following
 - 5. to BellSouth SWA or Special Access (a.k.a. BellSouth SPA) installation, moves and arrangements of service with an agreed upon service date interval of four business days or less following the Application Date of the service order.

In addition, Service Installation Guarantees will not apply during a declared National Emergency. Priority installation of National Security Emergency Preparedness (NSEP) telecommunications services shall take precedence.

E2.4.11 Provision For Certain State And Local Taxes And Fees

- A. Effective June 1, 2007, the Company will add to the bills of subscribers a surcharge to recover the KY Gross Revenues Tax (GRT) imposed by KRS 136.616. This will appear as a separate line item on the customer's bill and will read: KY GRT Surcharge.

BELLSOUTH
TELECOMMUNICATIONS, INC.
KENTUCKY
ISSUED: November 13, 1998
BY: E.C. Roberts, Jr., President - KY
Louisville, Kentucky

ACCESS SERVICES TARIFF

PSC KY. TARIFF 2E
Ninth Revised Page 18.3
Cancels Eighth Revised Page 18.3
EFFECTIVE: December 14, 1998

E2. GENERAL REGULATIONS

E2.5 Connections

E2.5.1 General

- A. Equipment and Systems (i.e., terminal equipment, multiline terminating systems and communications systems) may be connected with BellSouth SWA and Special Access (a.k.a. BellSouth SPA) service furnished by the Company where such connection is made in accordance with the provisions specified in Technical Reference Publication AS No. 1 and in E2.1 preceding.

E2.6 Definitions

Certain terms used herein are defined as follows:

ACCESS CODE

The term "Access Code" denotes a uniform seven digit code assigned by the Company to an individual customer. The seven digit code has the form 101XXXX, 950-0XXX or 950-1XXX.

ACCESS MINUTES

The term "Access Minutes" denotes that usage of exchange facilities in intrastate service for the purpose of calculating chargeable usage. On the originating end of an intrastate call, usage is measured from the time the originating End User's call is delivered by the Company to and acknowledged as received by the customer's facilities connected with the originating exchange. On the terminating end of an intrastate call, usage is measured from the time the call is received by the End User in the terminating exchange. Timing of usage at both originating and terminating ends of an intrastate call shall terminate when the calling or called party disconnects, whichever event is recognized first in the originating and terminating end exchanges, as applicable.

ACCESS ORDER

The term "Access Order" denotes a request for service received by the Company from a customer or the customer's authorized agent.

ACCESS TANDEM

The term "Access Tandem" denotes a Company switching system that provides a concentration and distribution function for originating or terminating traffic between end offices and a customer's premises.

ACCESS TANDEM NETWORK

The term "Access Tandem Network" denotes the network of trunk groups for originating and/or terminating BellSouth SWA traffic between a single access tandem and Company subtending end offices.

ACCESS TANDEM SWITCHING

Access Tandem Switching denotes a rate element which is assessed for switching a customer's traffic through the Access Tandem.

ALTERNATE CENTRAL OFFICE

The term "Alternate Central Office" denotes a wire center other than the serving wire center of the location of a customer node associated with BellSouth Dedicated Ring and SMARTRing[®] service (a.k.a. BellSouth Dedicated Ring).

ANSWER/DISCONNECT SUPERVISION

The term "Answer/Disconnect Supervision" denotes the transmission of the switch trunk equipment supervisory signal (off-hook or on-hook) to the customer's point of termination as an indication that the called party has answered or disconnected.

ATM

The term Asynchronous Transfer Mode (ATM) denotes one of the general class of packet switching technologies that relay traffic via an address contained within the packet (referred to in ATM as cells). ATM is a switching method in which information does not occur periodically with respect to some reference such as a frame pattern. (N)

ATM CELL

The term ATM cell denotes the fixed length packets utilized in ATM cell-based switching services. An ATM cell is 53 bytes long, consisting of a five-byte header containing the address and a fixed 48-byte information field. (N)

ATM CELL-BASED SWITCHING

The term ATM cell-based switching denotes the transfer of fixed length ATM cells as opposed to variable length frames used in other packet switching technologies. (N)

ATTENUATION DISTORTION

The term "Attenuation Distortion" denotes the difference in loss at specified frequencies relative to the loss at 1004 Hz, unless otherwise specified.

BALANCE (100 TYPE) TEST LINE

The term "Balance (100 Type) Test Line" denotes an arrangement in an end office which provides for balance and noise testing. (M)

BELLSOUTH
TELECOMMUNICATIONS
KENTUCKY
ISSUED: August 5, 2016
BY: Hood Harris, President
Louisville, Kentucky

ACCESS SERVICES TARIFF

PSC KY. TARIFF 2E
Tenth Revised Page 19
Cancels Ninth Revised Page 19
EFFECTIVE: August 20, 2016

E2. GENERAL REGULATIONS

E2.6 Definitions (Cont'd)

BASIC SERVICE ELEMENT

The term Basic Service Element denotes an optional network capability associated with a BellSouth SWA Basic Serving Arrangement.

BELLSOUTH CUSTOM NETWORK SERVICE

The term "BellSouth Custom Network Service" refers to the provisioning of custom-designed networks composed of various Special Access (a.k.a. BellSouth SPA) services. The rates and regulations for such networks, or arrangements, are found in E7.7.

BELLSOUTH DIRECTORY ASSISTANCE (INTRASTATE)

The term "BellSouth Directory Assistance" denotes the provision of telephone numbers by a Company operator when the operator location is accessed by a customer by dialing (NPA) 555-1212.

BELLSOUTH DIRECTORY ASSISTANCE LOCATION (INTERSTATE)

The term "BellSouth Directory Assistance Location" denotes a Company office where Company equipment first receives the BellSouth Directory Assistance call from a customer's premises and selects the first operator position to respond to the BellSouth Directory Assistance call.

BELLSOUTH OPERATOR SERVICES SYSTEM LOCATION

The term "BellSouth Operator Services System Location" (OSS location) denotes a Company office where Company equipment routes or receives IC Operator Services calls to or from the IC location.

BELLSOUTH SWA BASIC SERVING ARRANGEMENT

The term BellSouth SWA Basic Serving Arrangement denotes the connection of a customer to and through the BOCs networks, and should be considered the fundamental connection to those networks.

BELLSOUTH SWA COMMON TRANSPORT

The term "BellSouth SWA Common Transport" denotes the transmission of the customer's switched access traffic between the customer's serving wire center and the customer's designated Company end office (when BellSouth SWA Common Transport is ordered by the customer and traffic is switched through the Access Tandem), between the Access Tandem and the end office, between the BellSouth SWA FGA dial tone office and the end office (for terminating traffic) and, between the end office which serves as the host office for a remote switching system or module (RSS or RSM) and the RSS or RSM.

BELLSOUTH SWA DEDICATED TRANSPORT

The term "BellSouth SWA Dedicated Transport" denotes the transmission of the customer's switched access traffic utilizing dedicated facilities between the customer's serving wire center (SWC) and customer designated points, i.e. SWC to a Company Facility Hub (Hub), SWC to an Access Tandem, SWC to a customer designated end office, Hub to an Access Tandem, Hub to Hub, and Hub to an end office.

BELLSOUTH SWA FGD AND BELLSOUTH SWA TSBSA 3

The term "BellSouth SWA FGD and BellSouth SWA TSBSA 3" denotes the signaling system which is used, by equal access end offices, to transmit originating information and address digits to the customer's premises. Features of this system include overlap outpulsing, identification of the type of call, identification of the ten-digit telephone number of the calling party, and acknowledgment wink supervisory signals.

BELLSOUTH WATS SERVING OFFICE

The term "BellSouth SWA WATS Serving Office" denotes a telephone company designated serving wire center where switching, screening and/or recording functions are performed in connection with the closed-end of BellSouth SWA WATS or BellSouth SWA WATS-type services.

BILLING PERIOD

Each Billing Period is considered to have 30 days.

BIPOLAR WITH 8 ZERO SUBSTITUTION (B8ZS)

The term "Bipolar with 8 Zero Substitution" (B8ZS) denotes a line code which allows transport of an all zero octet over a DS1/1.544 Mbps High Capacity channel. B8ZS enables Clear Channel Capability on DS1/1.544 Mbps High Capacity service.

(D)
|
(D)

BELLSOUTH
TELECOMMUNICATIONS, INC.
KENTUCKY
ISSUED: May 16, 2001
BY: E.C. Roberts, Jr., President - KY
Louisville, Kentucky

ACCESS SERVICES TARIFF

PSC KY. TARIFF 2E
Fifth Revised Page 19.0.1
Cancels Fourth Revised Page 19.0.1
EFFECTIVE: June 15, 2001

E2. GENERAL REGULATIONS**E2.6 Definitions (Cont'd)****BIT**

The term "Bit" denotes the smallest unit of information in the binary system of notation.

BUSINESS DAY

The term "Business Day" denotes the times of day that a company is open for business. Generally, in the business community, these are 8:00 or 9:00 A.M. to 5:00 or 6:00 P.M., respectively, with an hour for lunch, Monday through Friday, resulting in a standard forty (40) hour work week. However Business Day hours for the Company may vary based on Company Policy, union contract and location.

CALL

The term "Call" denotes a customer attempt for which the complete address code (e.g., 0-, 911, or 10 digits) is provided to the serving dial tone office or in the case of BellSouth SWA 8XX Toll Free Dialing Ten Digit Screening service or BellSouth SWA 900 service when the address code is provided to the office performing the translation or screening function.

CARRIER IDENTIFICATION CODE (CIC)

The term "Carrier Identification Code" (CIC) denotes a unique access identification code that is assigned to an Interexchange Carrier for use with BellSouth SWA FGB (three digit access identification code) and/or BellSouth SWA FGD (four digit access identification code) service.

CARRIER OR COMMON CARRIER

See Interexchange Carrier

CCS

The term "CCS" denotes a hundred call seconds which is a standard unit of traffic load that is equal to 100 seconds of usage or capacity of a group of servers (e.g., trunks).

CCS7 SIGNALING CONNECTION

The CCS7 Signaling Connection provides a 56 kbps facility dedicated to a single customer which originates at the customer's signaling point of interconnection in a LATA and terminates at a Company Signaling Transfer Point (STP) selected by the Company. This facility, connecting the customer to a BellSouth STP, is ordered to a Company FSPOI within the same LATA as the customer's signaling point of interconnection. (N)

CCS7 SIGNALING TERMINATION

The CCS7 Signaling Termination provides a dedicated point of interface at a Company STP for a customer's CCS7 Signaling Connection. (N)

CCS7 ACCESS ARRANGEMENT

CCS7 Signaling Arrangement Usage refers to messages traversing the Company's CCS7 Signaling network for call set-up (ISUP) and non-call set-up (TCAP) purposes. (N)

CENTRAL OFFICE

The term "Central Office" denotes a local Company switching system where Telephone Exchange Service customer station loops are terminated for purposes of interconnection to each other and to trunks.

CENTRAL OFFICE PREFIX

The term "Central Office Prefix" denotes the first three digits (NXX) of the seven digit telephone number assigned to customer's Telephone Exchange Service when dialed on a local basis.

CENTRALIZED AUTOMATIC REPORTING ON TRUNKS TESTING

The term "Centralized Automatic Reporting on Trunks Testing" denotes a type of testing which includes the capacity for measuring operational and transmission parameters.

CENTREX TYPE SERVICES

Central office based non-transport arrangements which permit abbreviated internal calling, and inward and outward calling from station lines associated with ESSX-1 service, ESSX[®] service, Digital ESSX[®] service, MultiServ[®] service, MultiServ[®] PLUS service, and BellSouth[®] Centrex service.

BELLSOUTH
TELECOMMUNICATIONS, INC.
KENTUCKY
ISSUED: May 16, 2001
BY: E.C. Roberts, Jr., President - KY
Louisville, Kentucky

ACCESS SERVICES TARIFF

PSC KY. TARIFF 2E
Second Revised Page 19.1
Cancels First Revised Page 19.1
EFFECTIVE: June 15, 2001

E2. GENERAL REGULATIONS

E2.6 Definitions (Cont'd)

CHANNEL(S)

The term "Channel(s)" denotes an electrical or photonic, in the case of fiber optic-based transmission systems, communications path between two or more points of termination.

CHANNEL SERVICE UNIT

The term "Channel Service Unit" denotes equipment which performs one or more of the following functions: termination of a digital facility, regeneration of digital signals, detection and/or correction of signal format errors and remote loop back.

CHANNELIZATION EQUIPMENT

Equipment which derives individual channels of voice and/or data from a higher capacity to a lower capacity or bandwidth or vice versa.

(N)

(N)

BELLSOUTH
 TELECOMMUNICATIONS
 KENTUCKY
 ISSUED: June 17, 2013
 BY: Tony Taylor, Executive Director
 Louisville, Kentucky

ACCESS SERVICES TARIFF

PSC KY. TARIFF 2E
 Twelfth Revised Page 20
 Cancels Eleventh Revised Page 20
 EFFECTIVE: July 2, 2013

E2. GENERAL REGULATIONS**E2.6 Definitions (Cont'd)****CHANNELIZE**

The term "Channelize" denotes the process of multiplexing-demultiplexing wider bandwidth or higher speed channels into narrower band-width or lower speed channels, and vice versa.

CLEAR CHANNEL CAPABILITY

The term "Clear Channel Capability" denotes the ability to transport twenty-four, 64Kbps channels over a 1.544 Mbps High Capacity service via B8ZS line code format.

C-MESSAGE NOISE

The term "C-Message Noise" denotes the frequency weighted average noise within an idle voice channel. The frequency weighting, called C-message, is used to simulate the frequency characteristic of the 500-type telephone set and the hearing of the average subscriber.

C-NOTCHED NOISE

The term "C-Notched Noise" denotes the C-message frequency weighted noise on a voice channel with a holding tone, which is removed at the measuring end through a notch (very narrow band) filter.

(DELETED)**COMMON LINE**

The term "Common Line" denotes a line, trunk, pay telephone line or other facility provided under the General Subscriber Service Tariff of the Company, terminated on a central office switch. A common line-residence is a line or trunk provided under the residence regulations of the General Subscriber Service Tariff. A common line-business is a line provided under the business regulations of the General Subscriber Service Tariff.

COMMUNICATIONS SYSTEM

The term "Communications System" denotes channels and other facilities which are capable of communications between terminal equipment provided by other than the Company.

COMPANY

Whenever used in this Tariff, the term "Company" or the name South Central Bell Telephone Company denotes BellSouth Telecommunications, LLC

(C)

CUSTOMER(S)

The term "Customer(s)" denotes any individual, partnership, association, joint-stock company, trust, corporation, or governmental entity or other entity which subscribes to the services offered under this Tariff, including both Interexchange Carriers (ICs) and End Users except in Section 6 of Tariff FCC No. 1, BellSouth SWA service, where "Customer(s)" denotes Interexchange Carriers (ICs), Enhanced Service Providers (ESPs), End Users for BellSouth SWA FGA FX/ONAL service, and 500 Service Providers for BellSouth SWA 500 service.

(C)

BELLSOUTH
TELECOMMUNICATIONS
KENTUCKY
ISSUED: January 17, 1997
BY: Hood Harris, President
Louisville, Kentucky

ACCESS SERVICES TARIFF

PSC KY. TARIFF 2E
Third Revised Page 20.1
Cancels Second Revised Page 20.1
EFFECTIVE: February 16, 1997

E2. GENERAL REGULATIONS**E2.6 Definitions (Cont'd)**

DATA TRANSMISSION (107 TYPE) TEST LINE

The term "Data Transmission (107 Type) Test Line" denotes an arrangement which provides for a connection to a signal source which provides test signals for one-way testing of data and voice transmission parameters.

DECIBEL

The term "Decibel" denotes a unit used to express relative difference in power, usually between acoustic or electric signals, equal to ten (10) times the common logarithm of the ratio of two signal powers.

DECIBEL REFERENCE NOISE C-MESSAGE WEIGHTING

The term "Decibel Reference Noise C-Message weighting" denotes noise power measurements with C-Message Weighting in decibels relative to a reference 1000 Hz tone of 90 dB below 1 milliwatt.

DECIBEL REFERENCE NOISE C-MESSAGE REFERENCED TO 0

The term "Decibel Reference Noise C-Message Referenced to 0" denotes noise power in "Decibel Reference Noise C-Message Weighting" referred to or measured at a zero transmission level point.

(M)

DEMARICATION POINT

The point of demarcation and/or interconnection between Company communications facilities and terminal equipment, protective apparatus or wiring at a subscriber's premises. Company-installed facilities at, or constituting, the demarcation point shall consist of wire or a jack conforming to Subpart F of Part 68 of the Federal Communications Commission's rules. "Premises" as used herein generally means a dwelling unit, other building or a legal unit of real property such as a lot on which a dwelling unit is located, as determined by the Company's reasonable and nondiscriminatory standard operating practices.

DETAIL BILLING

The term "Detail Billing" denotes the listing of each message and/or rate element for which charges to a customer are due on a bill prepared by the Company.

BELLSOUTH
 TELECOMMUNICATIONS, INC.
 KENTUCKY
 ISSUED: April 21, 2000
 BY: E.C. Roberts, Jr., President - KY
 Louisville, Kentucky

ACCESS SERVICES TARIFF

PSC KY. TARIFF 2E
 Fourth Revised Page 21
 Cancels Third Revised Page 21
 EFFECTIVE: May 21, 2000

E2. GENERAL REGULATIONS**E2.6 Definitions (Cont'd)****DS0**

This denotes a channel service expressed in terms of its digitally encoded data bit rate in accordance with the North American hierarchy of digital signal levels. It is generally referred to as having a 64 Kbps transmission data rate signal; however, customer transmitted bit rates are limited to 56 Kbps. The required format and interface specifications are contained in BellSouth Technical Reference TR-NPL-000341.

DS1

This denotes a channel service expressed in terms of its digitally encoded data bit rate in accordance with the North American hierarchy of digital signal levels. It has a 1.544 Mbps transmission data rate, and provides for the two-way simultaneous transmission of isochronous timed, Bipolar Return-to-Zero (BPRZ) bit stream format. Unframed signal formats are not permitted or compatible with Company equipment. The required format and interface specifications are contained in BellSouth Technical Reference TR-NPL-000054.

DUAL TONE MULTIFREQUENCY ADDRESS SIGNALING

The term "Dual Tone Multifrequency Address Signaling" denotes a type of signaling that is an optional feature of BellSouth SWA FGA and BellSouth SWA LSBSA. It may be utilized when BellSouth SWA FGA or BellSouth SWA LSBSA is being used in the terminating direction (from the point of interface with the customer to the local exchange end office). An office arranged for Dual Tone Multifrequency Signaling would expect to receive address signals from the customer in the form of Dual Tone Multifrequency signals.

ECHO CONTROL

The term "Echo Control" denotes the control of reflected signals in a telephone transmission path.

ECHO PATH LOSS

The term "Echo Path Loss" denotes the measure of reflected signal at a 4-wire point of termination without regard to the send and receive Transmission Level Point.

ECHO RETURN LOSS

The term "Echo Return Loss" denotes a frequency weighted measure of return loss over the middle of the voiceband (approximately 500 to 2500 Hz), where talker echo is most annoying.

EFFECTIVE 2-WIRE

The term "Effective 2-Wire" denotes a condition which permits the simultaneous transmission in both directions over a channel, but it is not possible to insure independent information transmission in both directions. Effective 2-wire channels may be terminated with 2-wire or 4-wire interfaces.

EFFECTIVE 4-WIRE

The term "Effective 4-Wire" denotes a condition which permits the simultaneous independent transmission of information in both directions over a channel. The method of implementing effective 4-wire transmission is at the discretion of the Company (physical, time domain, frequency-domain separation or echo cancellation techniques). Effective 4-wire channels may be terminated with a 2-wire interface at the customer's premises. However, when terminated 2-wire, simultaneous independent transmission cannot be supported because the 2-wire interface combines the transmission paths into a single path.

EGRESS CIRCUITS

The term "Egress Circuits" denotes the facility used to transport the customer's dialed BellSouth® Remote Access Service traffic to the customer's designated location once it has been collected and aggregated by the remote access server.

(N)

(N)

BELLSOUTH
TELECOMMUNICATIONS
KENTUCKY
ISSUED: August 5, 2016
BY: Hood Harris, President
Louisville, Kentucky

ACCESS SERVICES TARIFF

PSC KY. TARIFF 2E
Fifth Revised Page 21.1
Cancels Fourth Revised Page 21.1
EFFECTIVE: August 20, 2016

E2. GENERAL REGULATIONS

E2.6 Definitions (Cont'd)

END OFFICE SWITCH

The term "End Office Switch" denotes a local Company switching system where Telephone Exchange Service customer station loops are terminated for purposes of interconnection to trunks. Included are Remote Switching Modules and Remote Switching Systems served by a host office in a different wire center.

END USER

The term "End User" denotes any customer of an intrastate telecommunications service that is not a carrier, except that a carrier other than a company shall be deemed to be an "end user" when such carrier uses a telecommunications service for administrative purposes and a person or entity that offers telecommunications services exclusively as a reseller shall be deemed to be an "End User" if all resale transmission offered by such reseller originate on the premises of such reseller.

ENHANCED SERVICE PROVIDER (ESP)

An ESP provides enhanced and/or information services which are defined as those services offered over the Company's common carrier facilities and which employ computer processing applications that: act on the format, content, code, protocol, or similar aspects of the end user's transmitted information; provide the end user additional, different, or restructured information; or involve end user interaction with stored information.

ENTRANCE FACILITY

See Switched Local Channel.

ENTRY SWITCH

See First Point of Switching.

ENVELOPE DELAY DISTORTION

The term "Envelope Delay Distortion" denotes a measure of the linearity of the phase versus frequency of a channel.

(D)
|
(D)

BELLSOUTH
 TELECOMMUNICATIONS, INC.
 KENTUCKY
 ISSUED: May 16, 2001
 BY: E.C. Roberts, Jr., President - KY
 Louisville, Kentucky

ACCESS SERVICES TARIFF

PSC KY. TARIFF 2E
 Fifth Revised Page 22
 Cancels Fourth Revised Page 22
 EFFECTIVE: June 15, 2001

E2. GENERAL REGULATIONS**E2.6 Definitions (Cont'd)****EQUAL LEVEL ECHO PATH LOSS**

The term "Equal Level Echo Path Loss" (ELEPL) denotes the measure of Echo Path Loss (EPL) at a 4-wire interface which is corrected by the difference between send and receive Transmission Level Point (TLP). (ELEPL = EPL - TLP (send) + TLP (receive)).

EXCHANGE

The term "Exchange" denotes a unit generally smaller than a Local Access and Transport Area, established by the Company for the administration of communications service in a specified area which usually embraces a city, town or village and its environs. It consists of one or more central offices together with the associated facilities used in furnishing communications service within that area. One or more designated exchanges comprised a given Local Access and Transport Area.

EXPECTED MEASURED LOSS (EML)

The term "Expected Measured Loss" denotes a calculated loss which specifies the end-to-end 1004-Hz loss on a terminated test connection between two readily accessible manual or remote test points. It is the sum of the inserted connection loss and test access loss including any test pads.

FACILITY SIGNALING POINT OF INTERCONNECTIONS (FSPOI)

The term "Facility Signaling Point Of Interconnection" denotes a Company-designated ordering point within a Company LATA to which customers may order CCS7 Signaling Connections. (N)

FIELD IDENTIFIER

The term "Field Identifier" denotes two to four characters that are used on service orders to convey specific instructions. Field Identifiers may or may not have associated data. Selected Field Identifiers are used in Company billing systems to generate nonrecurring charges. (N)

FIRST-COME, FIRST-SERVED

The term "First-Come, First-Served" denotes a procedure followed when the first order received will be the first order processed.

FIRST POINT OF SWITCHING

The term "First Point of Switching" denotes the first Company location at which switching occurs on the terminating path of a call proceeding from the customer premises to the terminating end office and, at the same time, the last Company location at which switching occurs on the originating path of a call proceeding from the originating end office to the customer premises.

FREQUENCY SHIFT

The term "Frequency Shift" denotes the change in the frequency of a tone as it is transmitted over a channel.

GRANDFATHERED

The term "Grandfathered" denotes Terminal Equipment, Multiline Terminating Systems, and Protective Circuitry directly connected to the facilities utilized to provide services under the provisions of this Tariff, and which are considered grandfathered under Part 68 of the F.C.C.'s Rules and Regulations.

HOST OFFICE

The term "Host Office" denotes an electronic switching system which provides call processing capabilities for one or more Remote Modules or Remote Systems.

HUB

The term "Hub" denotes a Company designated location at which services are either joined together (as in a bridging hub) or where services are multiplexed or demultiplexed (as in a Hi-Capacity hub).

BELLSOUTH
 TELECOMMUNICATIONS, INC.
 KENTUCKY
 ISSUED: April 21, 2000
 BY: E.C. Roberts, Jr., President - KY
 Louisville, Kentucky

ACCESS SERVICES TARIFF

PSC KY. TARIFF 2E
 Eighth Revised Page 23
 Cancels Seventh Revised Page 23
 EFFECTIVE: May 21, 2000

E2. GENERAL REGULATIONS**E2.6 Definitions (Cont'd)****IMMEDIATELY AVAILABLE FUNDS**

The term "Immediately Available Funds" denotes a corporate or personal check drawn on a bank account and funds which are available for use by the receiving party on the same day on which they are received and include U.S. Federal Reserve bank wire transfers, U.S. Federal Reserve notes (paper cash), U.S. coins, U.S. Postal Money Orders and New York Certificates of Deposit.

IMPEDANCE BALANCE

The term "Impedance Balance" denotes the method of expressing Echo Return Loss and Singing Return Loss at a four-wire interface whereby the gains and/or loss of the four-wire portion of the transmission path, including the hybrid, are not included in the specification.

IMPULSE NOISE

The term "Impulse Noise" denotes any momentary occurrence of the noise on a channel over a specified level threshold. It is evaluated by counting the number of occurrences, which exceed the threshold.

INDIVIDUAL CASE BASIS

The term "Individual Case Basis" denotes a condition in which the regulations, if applicable, rates and charges for an offering under the provisions of this Tariff are developed based on the circumstances in each case.

INGRESS CIRCUITS

The term "Ingress Circuits" denotes the facility used to transport the customer's incoming dialed BellSouth® Remote Access Service traffic, e.g. Primary Rate ISDN. (N)

INSERTED CONNECTION LOSS

The term "Inserted Connection Loss" denotes the 1004 Hz power difference (in dB) between the maximum power available at the originating end and the actual power reaching the terminating end through the inserted connection. (N)

INTEGRATED SERVICES DIGITAL NETWORK USER PART (ISDNUP)

An SS7 protocol which provides internetwork signaling to support circuit control, ISDN access signaling and specialized subscriber facilities.

INTERCONNECTION

Interconnection denotes the several Interconnection rate elements that apply to BellSouth SWA minutes of use. Separate rate elements are applicable for originating and terminating minutes of use. Additionally, separate rate elements are applicable when the customer utilizes Company-provided transport facilities versus those service applications where there are no Company transport facilities utilized.

INTEREXCHANGE CARRIER (IC) OR INTEREXCHANGE COMMON CARRIER

The terms "Interexchange Carrier (IC)" or "Interexchange Common Carrier" denotes any individual, partnership, association, joint-stock company trust, governmental entity or corporation engaged for hire in intrastate communications by wire or radio, between two or more exchanges.

INTERMODULATION DISTORTION

The term "Intermodulation Distortion" denotes a measure of the nonlinearity of a channel. It is measured using four tones, and evaluating the ratios (in dB) of the transmitted composite four -tone signal power to the second-order products of the tones (R2), and the third-order products of the tones (R3).

INTERSTATE COMMUNICATIONS

The term "Interstate Communications" denotes both interstate and foreign communications.

INTRASTATE COMMUNICATIONS

The term "Intrastate Communications" denotes any communications within the state subject to oversight by the state regulatory commission as provided by the laws of the state.

BELLSOUTH
TELECOMMUNICATIONS
KENTUCKY
ISSUED: March 3, 1997
BY: Hood Harris, President
Louisville, Kentucky

ACCESS SERVICES TARIFF

PSC KY. TARIFF 2E
First Revised Page 23.1
Cancels Original Page 23.1
EFFECTIVE: April 1, 1997

E2. GENERAL REGULATIONS**E2.6 Definitions (Cont'd)**

LINE CONTROLLED PAY STATIONS

The term "Line Controlled Pay Stations" denotes line controlled pay stations utilizing Telephone Company serving central office equipment for the necessary call processing features required for pay telephone traffic. Traffic from these stations will be completed to the customer over BellSouth SWA TSBSA 3 trunks which must be equipped with the Coin Sent-Paid Capability optional feature.

(N)

(N)

LINE SIDE CONNECTION

The term "Line Side Connection" denotes a connection of a transmission path to the line side of a local exchange switching system.

LOCAL ACCESS AND TRANSPORT AREA

The term "Local Access and Transport Area" denotes a geographic area established for the provision and administration of communications service. It encompasses one or more designated exchanges, which are grouped to serve common social, economic and other purposes.

LOCAL CALLING AREA

The term "Local Calling Area" denotes a geographical area, as defined in the Company's General Subscriber Service Tariff, in which an end user (Telephone Exchange Service Subscriber) may complete a call without incurring MTS charges.

BELLSOUTH
 TELECOMMUNICATIONS
 KENTUCKY
 ISSUED: March 3, 1997
 BY: Hood Harris, President
 Louisville, Kentucky

ACCESS SERVICES TARIFF

PSC KY. TARIFF 2E
 Fifth Revised Page 24
 Cancels Fourth Revised Page 24
 EFFECTIVE: April 1, 1997

E2. GENERAL REGULATIONS**E2.6 Definitions (Cont'd)**

LOCAL TANDEM SWITCH

The term "Local Tandem Switch" denotes a local Company switching unit by which local or access telephonic communications are switched to and from an End Office Switch.

LOCATION PROVIDER

*The term "Location Provider" denotes the person or persons having a legal authority to permit the **Payphone Service Provider** to place pay telephones on their premises.* (C)

LOOP AROUND TEST LINE

The term "Loop Around Test Line" denotes an arrangement utilizing a Company central office to provide a means to make certain two-way transmission tests on a manual basis. This arrangement has two central office terminations, each reached by means of separate telephone numbers and does not require any specific customer premises equipment. Equipment subject to this test arrangement is at the discretion of the customer.

LOSS DEVIATION

The term "Loss Deviation" denotes the variation of the actual loss from the designed value.

MAJOR FRACTION THEREOF

The term "Major Fraction Thereof" is any period of time in excess of 1/2 of the stated amount of time. As an example, in considering a period of 24 hours, a major fraction thereof would be any period of time in excess of 12 hours exactly. Therefore, if a given service is interrupted for a period of thirty-six hours and fifteen minutes, the customer would be given a credit allowance for twenty-four hour periods for a total of forty-eight hours.

MARITIME RADIO COMMON CARRIERS (MRCCs)

The term "Maritime Radio Common Carriers (MRCCs)" denotes carriers which are regulated under Part 81 of the Federal Communications Commission's Rules and Regulations.

MESSAGE

The term "Message" denotes a "call" as defined preceding.

MILLIWATT (102 TYPE) TEST LINE

The term "Milliwatt (102 Type) Test Line" denotes an arrangement in an end office which provides a 1004 Hz tone at 0 dBm0 for one-way transmission measurements towards the customer's premises from the Company end office.

MINUTES OF USE (See Access Minutes)

MOBILE TELEPHONE SWITCHING OFFICE (MTSO)

The term "Mobile Telephone Switching Office (MTSO)" denotes a Cellular Mobile Carrier (CMC) switching system that is used to terminate mobile stations for purposes of interconnection to each other and to trunks interfacing with the public switched network.

NETWORK CHANNEL INTERFACE (NCI) CODE UPDATE

The term "Network Channel Interface (NCI) Code Update" denotes the manual or mechanical activity performed to update the NCI code on each sub-DS1 level circuit riding a DS1 High Capacity (a.k.a. BellSouth SPA DS1) service that is converted (rolled over) to a DS3 High Capacity (a.k.a. BellSouth SPA DS3) service.

NETWORK CONTROL SIGNALING

The term "Network Control Signaling" denotes the transmission of signals used in the telecommunications system which perform functions such as supervision (control, status, and charge signals), address signaling (e.g., dialing), calling and called number identifications, rate of flow, service selection error control and audible tone signals (call progress signals indicating re-order or busy conditions, alerting, coin denominations, coin collect and coin return tones) to control the operation of the telecommunications system.

BELLSOUTH
 TELECOMMUNICATIONS
 KENTUCKY
 ISSUED: January 4, 2012
 BY: Mary Pat Regan, President - KY
 Louisville, Kentucky

ACCESS SERVICES TARIFF

PSC KY. TARIFF 2E
 Fifth Revised Page 24.1
 Cancels Fourth Revised Page 24.1
 EFFECTIVE: January 19, 2012

E2. GENERAL REGULATIONS**E2.6 Definitions (Cont'd)**

NETWORK INTERFACE

Network Interface is a standard jack provided by the Company as a part of exchange access, *BellSouth SWA* WATS, or Private Line Services for the connection of customer terminal equipment and premises wiring to the telephone network. The Network Interface will be located at the demarcation point.

NONSYNCHRONOUS TEST LINE

The term "Nonsynchronous Test Line" denotes an arrangement in step-by-step end offices which provides operational tests which are not as complete as those provided by the synchronous test lines, but which can be made more rapidly.

NORTH AMERICAN NUMBERING PLAN

The term "North American Numbering Plan" denotes a three -digit area or Numbering Plan Area code and a seven -digit telephone number made up of a three -digit Central Office code plus a four -digit station number.

OFF-HOOK

The term "Off-hook" denotes the active condition of *BellSouth SWA* or a Telephone Exchange Service line.

ON-HOOK

The term "On-hook" denotes the idle condition of *BellSouth SWA* or a Telephone Exchange Service line.

OPEN CIRCUIT TEST LINE

The term "Open Circuit Test Line" denotes an arrangement in an end office which provides an ac open circuit termination of a trunk or line by means of an inductor of several Henries.

OPERATING COMPANY NUMBER denotes a four-character alphanumeric identifier used to determine the company of the NPA- (N)
 NXX code-holders. (N)

OPERATOR SERVICES SYSTEM

The term "Operator Services System" (OSS) denotes the switching equipment, facilities, operator positions and software components utilized for the provision of Operator Services.

OPERATOR SERVICES SYSTEM SERVING AREA

The term "Operator Services System Serving Area" (OSS serving area) denotes the geographic operational domain of an Operator Services System.

BELLSOUTH
TELECOMMUNICATIONS, INC.
KENTUCKY
ISSUED: April 21, 2000
BY: E.C. Roberts, Jr., President - KY
Louisville, Kentucky

ACCESS SERVICES TARIFF

PSC KY. TARIFF 2E
Seventh Revised Page 25
Cancels Sixth Revised Page 25
EFFECTIVE: May 21, 2000

E2. GENERAL REGULATIONS**E2.6 Definitions (Cont'd)****ORIGINATING DIRECTION**

The term "Originating Direction" denotes the use of Access Service for the origination of calls from an End User premises to an IC premises.

OVERLAP OUTPUTPULSING

The term "Overlap Outputpulsing" denotes the feature of the BellSouth SWA FGD and BellSouth SWA TSBSA 3 Signaling System which permits initiation of pulsing to the customer's premises before the calling subscriber has completed dialing an originating call.

PAY TELEPHONE LINE

The term "Pay Telephone Line" denotes facilities provided by the Company which connect pay telephone stations to the Local Exchange Network.

PAYPHONE SERVICE PROVIDER

The term "Payphone Service Provider" denotes one who provides payphone service, which is the provision of public or semi-public pay telephones, the provision of inmate telephone service in correctional institutions and any ancillary services.

PHASE JITTER

The term "Phase Jitter" denotes the unwanted phase variations of a signal.

POINT OF TERMINATION

The term "Point of Termination" denotes the point of demarcation, within a customer-designated premises at which the Company's responsibility for the provision of Access Service ends.

PREMISES

The term "Premises" denotes a building, or a portion of a building in a multitenant building, or buildings on continuous property (except Railroad Right-of-Way, etc.) not separated by a public highway, except for an end user that offers Telecommunications Services exclusively as a reseller. This term is not to be limited to one building, but applies as well to a complex, or campus-type configuration of buildings.

PURE RESELLER

The term "Pure Reseller" denotes a customer authorized by the Public Service Commission to purchase intrastate telecommunications services for the purpose of reselling MTS, BellSouth SWA WATS or MTS/BellSouth SWA WATS-Like services to its end users.

Pure Resellers may provide access to their systems through BellSouth SWA 800 WATS or BellSouth SWA FGA, BellSouth SWA FGB, BellSouth SWA FGD, BellSouth SWA LSBSA or BellSouth SWA TSBSA 1 or BellSouth SWA TSBSA 3 services. They may transport traffic over resold MTS, BellSouth SWA WATS or MTS/BellSouth SWA WATS-Like Services. Pure Resellers may not originate and terminate a call within the LATA over BellSouth SWA service.

RADIO COMMON CARRIERS (RCC)

The term "Radio Common Carriers (RCC)" denotes carriers which are regulated under Part 22 of the Federal Communications Commission's Rules and Regulations.

REGISTERED EQUIPMENT

The term "Registered Equipment" denotes the customer's premises equipment which complies with and has been approved within the Registration Provisions of Part 68 of the F.C.C.'s Rules and Regulations.

REMOTE ACCESS SERVER

The term "Remote Access Server" denotes equipment that aggregates the customer's BellSouth® Remote Access Service dial traffic and transports it to the customer's designated location over their egress circuits.

(N)

(N)

REMOTE SWITCHING MODULES AND/OR REMOTE SWITCHING SYSTEMS

The term "Remote Switching Modules and/or Remote Systems" denotes small, remotely controlled electronic end office switches which obtain their call processing capability from an ESS-type Host Office.

RETURN LOSS

The term "Return Loss" denotes a measure of the similarity between the two impedances at the junction of two transmission paths. The higher the return loss, the higher the similarity.

BELLSOUTH
 TELECOMMUNICATIONS, INC.
 KENTUCKY
 ISSUED: May 16, 2001
 BY: E.C. Roberts, Jr., President - KY
 Louisville, Kentucky

ACCESS SERVICES TARIFF

PSC KY. TARIFF 2E
 Tenth Revised Page 26
 Cancels Ninth Revised Page 26
 EFFECTIVE: June 15, 2001

E2. GENERAL REGULATIONS**E2.6 Definitions (Cont'd)****SECONDARY CHANNEL**

The term "Secondary Channel" denotes the offering of a companion digital transmission capability over the same physical facility as the primary channel at a lower bit rate. Terminal equipment required to support secondary channel capability must be provided by the customer.

SERVICE ACCESS CODE

The term "Service Access Code (SAC)" denotes the 700, 800 and 900 NXX numbers administered by Bell Communications Research as part of the North American Numbering Plan.

SERVICE INSTALLATION GUARANTEE

The term "Service Installation Guarantee" denotes a program under which the Company will provide a credit to the customer's account for certain services in those instances when the Service Date is not met due to Company reasons.

SERVICE SWITCHING POINT (SSP)

The term "Service Switching Point" (SSP) denotes a node in a CCS7 Signaling System that formulates and receives signaling messages. (N)

SERVING WIRE CENTER

The term "Serving Wire Center" denotes the wire center from which the customer designated premises would normally obtain dial tone from the Company. (N)

SEVEN DIGIT MANUAL TEST LINE

The term "Seven Digit Manual Test Line" denotes an arrangement which allows the customer to select balance, milliwatt and synchronous test lines by manually dialing a seven digit number over the associated access connection.

SHARED NETWORK ARRANGEMENT

The term "Shared Network Arrangement" denotes a service offering whereby multiple customers may connect on a channelized high capacity service and the Company will undertake to maintain separate records for each customer's portion of the shared network.

SHORT CIRCUIT TEST LINE

The term "Short Circuit Test Line" denotes an arrangement in an end office, which provides for an ac short circuit termination of the trunk or line by means of a capacitor of at least four microfarads.

SHORTAGE OF FACILITIES OR EQUIPMENT

The term "Shortage of Facilities or Equipment" denotes a condition which occurs when the Company does not have appropriate cable, switching capacity, bridging or channelization equipment, etc., necessary to provide the Access Service requested by the customer.

SIGNAL-TO-C-NOTCHED NOISE RATIO

The term "Signal-to-C-Notched Noise Ratio" denotes the ratio in dB of a test signal to the corresponding C-Notched Noise.

SIGNAL TRANSPORT POINT (STP)

The term "Signal Transfer Point" denotes a signaling point which routes and/or transfers signaling messages through the common channel signaling network.

SIGNALING POINT CODE

The term "Signaling Point Code" denotes a binary code uniquely identifying a signaling point in a signaling network. This code is used, depending upon its position in the label, either as a destination point code, identifying the intended destination of the message, or as an originating point code, identifying the originating point of the message.

SIGNALING POINT OF INTERCONNECTION (SPOI)

The term Signaling Point of Interconnection (SPOI) denotes the location where a Company-provided CCS7 Signaling Connection terminates at a customer location. (N)

BELLSOUTH
 TELECOMMUNICATIONS
 KENTUCKY
 ISSUED: August 5, 2016
 BY: Hood Harris, President
 Louisville, Kentucky

ACCESS SERVICES TARIFF

PSC KY. TARIFF 2E
 Ninth Revised Page 26.1
 Cancels Eighth Revised Page 26.1
 EFFECTIVE: August 20, 2016

E2. GENERAL REGULATIONS

E2.6 Definitions (Cont'd)

SINGING RETURN LOSS

The term "Singing Return Loss" denotes the frequency weighted measure of return loss at the edges of the voiceband (200 to 500 Hz and 2500 to 3200 Hz), where singing (instability) problems are most likely to occur.

SPECIAL ORDER

The term "Special Order" denotes an order for a Billing and Collection Service or an order for a *BellSouth* Directory Assistance *Access* service.

SUBTENDING END OFFICE OF AN ACCESS TANDEM

The term "Subtending End Office of an Access Tandem" denotes an end office that has final trunk group routing through that tandem.

SWITCHED LOCAL CHANNEL

The Switched Local Channel denotes a *BellSouth SWA* Transport facility between the customer's serving wire center and the customer's premises.

SYNCHRONOUS TEST LINE

The term "Synchronous Test Line" denotes an arrangement in an end office which performs marginal operational tests of supervisory and ring-tripping functions.

TELEPHONE COMPANY ANSWERING SERVICE CONCENTRATOR

The term "Telephone Company Answering Service Concentrator" denotes a device located in a central office of the Company which concentrates incoming calls to some number of Telephone Answering Service's client lines to some smaller number of trunks/channels connected to the customer's premises equipment.

TERMINATING DIRECTION

The term "Terminating Direction" denotes the use of Access Service for the completion of calls from an IC premises to an End User premises.

TERMINATION LIABILITY CHARGE

The term "Termination Liability Charge" when used in connection with specially constructed facilities denotes the portion of the Maximum Termination Liability that is applied as a nonrecurring charge when all services are discontinued prior to the expiration of the specified liability period. The term "Termination Liability" as used in connection with the application of termination charges for access services denotes the discontinuance, either at the request of the customer or by the Company under its regulations concerning cancellation for cause, of service or facilities (including channels and station equipment) provided by the Company.

TRADITIONAL SIGNALING

The term "Traditional Signaling" denotes the Intermachine Signaling System which has been traditionally used in North America for the purpose of transmitting the called number's address digits from the originating end office to the switching machine which will terminate the call. In this system, all of the dialed digits are received by the originating switching machine, a path is selected, and the sequence of supervisory signals and outpulsed digits is initiated. No overlap outpulsing, ten digit ANI or ANI information digits are included in this signaling sequence. Acknowledgment wink is required from the terminating switch machine except when the originating switch machine is SXS.

TRAFFIC

The term "traffic" denotes a volume of customer access minutes of use or calls.

TRAFFIC OPERATOR POSITION SYSTEM (TOPS) TANDEM

The term "Traffic Operator Position System" (TOPS tandem) denotes a Company office where Company equipment routes or receives IC Operator Services calls to or from the IC location. A TOPS tandem is also known as an OSS location.

(D)

BELLSOUTH
TELECOMMUNICATIONS
KENTUCKY
ISSUED: August 5, 2016
BY: Hood Harris, President
Louisville, Kentucky

ACCESS SERVICES TARIFF

PSC KY. TARIFF 2E
Eighth Revised Page 27
Cancels Seventh Revised Page 27
EFFECTIVE: August 20, 2016

E2. GENERAL REGULATIONS**E2.6 Definitions (Cont'd)****TRANSACTIONS CAPABILITIES APPLICATION PART (TCAP) MESSAGES**

The term "TCAP Message" relates to the application of TIA Interim Standard 41 (Sub-systems 005-010) for the transmission of non-call associated messages over the BellSouth SWA CCSAC network.

TRANSMISSION MEASURING (105 TYPE) TEST LINE/RESPONDER

The term "Transmission Measuring (105 Type) Test Line/Responder" denotes an arrangement in an end office which provides far-end access to a responder and permits two-way loss and noise measurements to be made on trunks from a near end office.

TRANSMISSION PATH

The term "Transmission Path" denotes an electrical path capable of transmitting signals within the range of the service offering, e.g., a voice grade transmission path is capable of transmitting voice frequencies within the approximate range of 300 to 3000 Hz. A transmission path is comprised of physical or derived channels consisting of any form or configuration of facilities typically used in the telecommunications industry.

TRUNK

The term "Trunk" denotes a communications path connecting two switching systems in a network, used in the establishment of an end-to-end connection.

TRUNK GROUP

The term "Trunk Group" denotes a set of trunks which are traffic engineered as a unit for the establishment of connections between switching systems in which all of the communications paths are interchangeable.

TRUNK-SIDE CONNECTION

The term "Trunk-Side Connection" denotes the connection of a transmission path to the trunk side of a local exchange switching system.

TWO-WIRE TO FOUR-WIRE CONVERSION

The term "Two-Wire to Four-Wire Conversion" denotes an arrangement which converts a four-wire transmission path to a two-wire transmission path to allow a four-wire facility to terminate in a two-wire entity (e.g., a central office switch).

UNIFORM SERVICE ORDER CODE

The term "Uniform Service Order Code" denotes a three or five character alphabetic, numeric, or an alphanumeric code that identifies a specific item of service or equipment. Uniform Service Order Codes are used in the Company billing system to generate recurring rates and nonrecurring charges.

UNUSABLE SERVICE

A customer's service is considered unusable when it becomes inoperative to the customer because of a failure of a facility component used to furnish service under this Tariff or when service fails to meet the technical performance specifications as set forth by this Tariff.

VIRTUAL COLLOCATION CROSS-CONNECT

A "Virtual Collocation Cross-Connect" provides for central office interconnection of collocater-provided Company leased transmission equipment to BellSouth SWA and Special Access (a.k.a. BellSouth SPA) services.

V AND H COORDINATES METHOD

The term "V and H Coordinates Method" denotes a method of computing airline miles between two points by utilizing an established formula which is based on the vertical (V) and horizontal (H) coordinates of the two points.

BELLSOUTH
 TELECOMMUNICATIONS, INC.
 KENTUCKY
 ISSUED: November 6, 2003
 BY: E.C. Roberts, Jr., President - KY
 Louisville, Kentucky

ACCESS SERVICES TARIFF

PSC KY. TARIFF 2E
 Eighth Revised Page 28
 Cancels Seventh Revised Page 28
 EFFECTIVE: December 6, 2003

E2. GENERAL REGULATIONS**E2.6 Definitions (Cont'd)****WIRE CENTER**

A "Wire Center" is a Company facility that houses Company equipment necessary for the provision of switched and non-switched telephone service to customers in a defined geographical area. The facility is identified with V&H coordinates and is assigned one or more NXX's for use in providing switched services to customers located in the specified geographical area. The Company equipment located at a Wire Center may consist of switching equipment or non-switched equipment working with a distant host switch as well as equipment used to terminate dedicated non-switched services. Wire Centers capable of terminating access facilities are designated by the Company.

500 SERVICE PROVIDER

The term "500 Service Provider" refers to a customer purchasing BellSouth SWA 500 service for use in the provision of Personal Communication Service. A 500 Service Provider must have been assigned a 500 NXX by the North American Numbering Plan Administrator.

800 DATABASE

The term "800 Database" refers to the use of database technology to determine to which access customer an originating 800 call is to be delivered. With the exception of 800 calls to Canada, Bermuda, and the Bahamas, the 800 Database routes calls to an access customer based on the dialed ten digit 800 number.

E2.7 Special Promotions**E2.7.1 Regulations**

- A. The Company may offer special promotions of new or existing services or products upon thirty (30) days notification to the Commission. These promotions are a temporary waiver of certain recurring, nonrecurring and/or usage charges or a one-time credit to a customer's account. Promotions will be offered on a completely nondiscriminatory basis with each subscriber in the classification of service and area for which the promotion is offered having an equal opportunity for participation. In the event that a promotion occurs during any other scheduled promotion, the customer may choose only one of the available promotions in which to participate. Notification will include the time period in which the promotion is to be conducted as well as the terms and conditions.

E2.7.2 Reserved For Future Use

(T)

E2.8 Reserved For Future Use**E2.9 Reserved For Future Use****E2.10 Reserved For Future Use****E2.11 Trademarks and Servicemarks Protection**

(T)

E2.11.1 Use of Trademarks and Servicemarks

(T)

Trademarks and Servicemarks owned by BellSouth Intellectual Property Corporation may not be used by any entity concurring in or providing services pursuant to this Tariff except under an express written license agreement with BellSouth Intellectual Property Marketing Corporation.

(T)

BELLSOUTH
 TELECOMMUNICATIONS
 KENTUCKY
 ISSUED: December 16, 2022
 BY: Cyndi Gallagher, Director – External Affairs

ACCESS SERVICES TARIFF

PSC KY. TARIFF 2E
 First Revised Page 29
 Cancels Original Page 29
 EFFECTIVE: January 1, 2023

E2. GENERAL REGULATIONS

E2.12 TDM to IP Transition

E2.12.1 General TDM to IP Transition Provisions

As a result of evolving network technology, the Telephone Company is able to offer new, advanced services. At the same time, certain older services will no longer be available in some geographic areas, as those services are no longer technically or economically feasible. The table below identifies services that have been withdrawn, by wire center and exchange, along with additional information related to these service withdrawals.

<u>Product Name</u>	<u>Reference</u>
Metallic (aka BellSouth SPA Metallic) Service	E7.2.1
Telegraph Grade (aka BellSouth SPA Telegraph) Service	E7.2.2
Voice Grade (aka BellSouth SPA DS0 VG) Service	E7.2.3
Digital Data Access (aka BellSouth SPA DS0 Digital Data) Service	E7.2.7
High Capacity (aka BellSouth SPA High Capacity) Service (64 kbps, 3.152 and 6.312 Mbps)	E7.2.8
Derived Data Channel (aka BellSouth SPA Derived Data Channel) Service	E7.2.15
FlexServ Service (aka BellSouth SPA Customer Reconfiguration)	E7.4.12

(D)

<u>Effective Date</u>	<u>Wire Center</u>	<u>Exchange</u>	<u>Other Information</u>
07/15/2020	PIVLKYMA	Pineville	Distribution Area 4203PA