

ACCESS SERVICE

7 - Special Access (a.k.a. BellSouth SPA) Service

7.1 General

Special Access (a.k.a. BellSouth SPA) service provides a transmission path to connect customer designated premises or a customer designated premises either directly or through a Telephone Company Hub where channelization functions is performed. Special Access (a.k.a. BellSouth SPA) service includes all exchange access not utilizing Telephone Company end office switches.

7.1.1 Channel Types

Descriptions of each of the channel types are provided in Part 11, Section 7.2 of this guidebook.

7.1.2 Rate Categories

The following rate categories apply to Special Access (a.k.a. BellSouth SPA) Service:

- Local Channels
- Interoffice Channels
- Optional Features and Functions
- SMARTRing service (a.k.a. BellSouth SPA Dedicated Ring) rate categories
- Fast Packet Access Services
- Optical Transport Access Services

(A) Local Channel

In general, the Local Channel rate category provides for the communications path between a customer-designated premises and the serving wire center of that premises. Included as part of the Local Channel is a standard channel interface arrangement which defines the technical characteristics associated with the type of facilities to which the access service is to be connected at the Point of Termination (POT) and the type of signaling capability, if any. The signaling capability itself is provided as an optional feature as set forth in Section 7.1.2(C). One Local Channel charge will apply per customer-designated premises at which the channel is terminated. This charge will also apply where the customer designated premises and the serving Wire Center are collocated in a Telephone Company building. This charge will also apply where both customer-designated premises are in the same building, or where the service is provided without physically traversing the serving wire center. The charge also applies where the designated premises is served from a wire center other than the one from which the customer would normally obtain dial tone, i.e., an alternate serving wire center. (T)

(B) Interoffice Channel

The Interoffice Channel rate category provides for the transmission facilities between the serving wire centers associated with two customer-designated premises, between a serving wire center associated with a customer-designated premises and a Telephone Company Hub or between two Telephone Company Hubs. A serving wire center associated with a customer-designated premises may be either the wire center from which the customer would normally obtain dial tone or an alternate serving wire center. An Interoffice Channel is portrayed in mileage bands. There are two rates that apply for each band, i.e., a flat rate per band and a rate per mile.

ACCESS SERVICE

7 - Special Access (a.k.a. BellSouth SPA) Service

7.1 General

7.1.2 Rate Categories

(C) Optional Features and Functions

The Optional Features and Functions rate category provides for optional features and functions, which may be added to a Special Access (a.k.a. BellSouth SPA) service to improve its quality or utility to meet specific communications requirements. These are not necessarily identifiable with specific equipment, but rather represent the end result in terms of performance characteristics which may be obtained. These characteristics may be obtained by using various combinations of equipment.

Although the equipment necessary to perform a specified function may be installed at various locations along the path of the service, they will be charged for as a single rate element.

Examples of Optional Features and Functions that are available include, but are not limited to, the following:

- Hubbing Functions
- Conditioning
- Transfer Arrangements
- BellSouth SPA Customer Network Management (CNM) - FlexServ Service

A Hub is a Telephone Company designated serving wire center at which bridging or channelization functions are performed. The bridging functions performed are to connect three or more customer designated premises in a multipoint arrangement. The channelization functions are to channelize analog or digital facilities to individual services requiring a lower capacity or bandwidth. National Exchange Carrier Association, Inc. Tariff F.C.C. No. 4 identifies serving wire centers, Hub locations and the type of bridging or multiplexing functions available.

(T)
(T)

ACCESS SERVICE

7 - Special Access (a.k.a. BellSouth SPA) Service

7.1 General

7.1.2 Rate Categories

(D) Self-healing Multi-nodal Alternate Route Topology Ring
(SMARTRing) Service (a.k.a. BellSouth SPA Dedicated Ring)

(1) Customer Node

Customer Nodes provide ring switching capabilities at customer designated locations other than Telephone Company Premises that are part of SMARTRing service (a.k.a. BellSouth SPA Dedicated Ring). This rate element offers OC-3, OC-3+, OC-12, OC-48, OC-48+, OC-192, or OC-192+ network capacities. An OC-1 network capacity is available only in an Overlay Ring Arrangement riding the customer's host OC-12, OC-48, or OC-48+ SMARTRing service (a.k.a. BellSouth SPA Dedicated Ring) installed on or after June 3, 1994. A summary of the channel interfaces available with each node are specified in Section 7.2.11(A). (D) (T)

OC-24 SMARTRing service (a.k.a. BellSouth SPA Dedicated Ring) customer nodes are only available to existing CSPP customers or under month-to-month arrangements.

(2) Customer Channel Interface

A Customer Channel Interface provides DS1, DS3, STS-1 electrical channelization and/or OC-3, OC-12, OC-48 and/or 1000 Mbps optical channelization that may take place at each Customer Node of SMARTRing service(a.k.a. BellSouth SPA Dedicated Ring). The Customer Channel Interface rate element applies for every interface capacity that originates or terminates at a Customer Node. A summary of the channel interfaces available with each node are specified in Section 7.2.11(A). (T)

(D)
|
(D)

ACCESS SERVICE

7 - Special Access (a.k.a. BellSouth SPA) Service

7.1 General

7.1.2 Rate Categories

(D) Self-healing Multi-nodal Alternate Route Topology Ring
(SMARTRing) Service (a.k.a. BellSouth SPA Dedicated Ring)

(3) Central Office Node

Central Office Nodes provide ring switching capabilities at Telephone Company Central Offices that are a part of SMARTRing service (a.k.a. BellSouth SPA Dedicated Ring). This rate element offers OC-3, OC-3+, OC-12, OC-48, OC-48+, OC-192, and OC-192+ network capacities. An OC-1 network capacity is available only in an Overlay Ring Arrangement riding the customer's host OC-12, OC-48 or OC-48+ SMARTRing service (a.k.a. BellSouth SPA Dedicated Ring) installed on or after June 3, 1994. A summary of the channel interfaces available with each node are specified in Section 7.2.11(A).

(T)
(D)

(D)
(D)
(D)

(4) Central Office Channel Interface

A Central Office Channel Interface provides DS1, DS3, STS-1 electrical channelization and/or OC-3, OC-12, OC-48 and/or 1000 Mbps optical channelization that may take place at each Central Office Node located on SMARTRing service (a.k.a. BellSouth SPA Dedicated Ring). The Central Office Channel Interface rate element applies for every interface capacity that originates or terminates at a Central Office Node. A summary of the channel interfaces available with each node are specified in Section 7.2.11(A).

(T)

(D)
|
(D)

ACCESS SERVICE

7 - Special Access (a.k.a. BellSouth SPA) Service

7.1 General

7.1.2 Rate Categories

(D) Self-healing Multi-nodal Alternate Route Topology Ring
(SMARTRing) Service (a.k.a. BellSouth SPA Dedicated Ring)

(4) Central Office Channel Interface

Customers with DS3 or STS-1 interfaces at the Customer Node electing to connect with DS1 services at a Central Office Node, must obtain a 28-DS1 Channel System.

(5) Local Channel

The Local Channel rate category provides for the communications path between a Customer Node and the serving wire center of the premises where located. Charges for Local Channels apply as described in Section 7.1.2(A). It is available with all capacities of SMARTRing service (a.k.a. BellSouth SPA Dedicated Ring) except OC-1. (T)

(6) Alternate Central Office Channel

The Alternate Central Office Channel provides for the communications path between a customer node and an alternate central office. It is available with all capacities of SMARTRing service (a.k.a. BellSouth SPA Dedicated Ring) except OC-1.

(7) Interoffice Channel

The Interoffice Channel provides for the communications path between directly connected Telephone Company central offices located on a SMARTRing service (a.k.a. BellSouth SPA Dedicated Ring). It is available with all capacities of SMARTRing service (a.k.a. BellSouth SPA Dedicated Ring) except OC-1. This rate element does not apply where Central Office Nodes are adjacently connected in the same Central Office on the same SMARTRing service (a.k.a. BellSouth SPA Dedicated Ring) for the purpose of providing additional node capacity.

ACCESS SERVICE

7 - Special Access (a.k.a. BellSouth SPA) Service

7.1 General

7.1.2 Rate Categories

(D) Self-healing Multi-nodal Alternate Route Topology Ring
(SMARTRing) (a.k.a. BellSouth SPA Dedicated Ring) Service

(8) Internodal Channel

The Internodal Channel (INC) provides for the communications path between two directly connected Customer Nodes of a given SMARTRing service (a.k.a. BellSouth SPA Dedicated Ring) located (a) in the same Serving Wire Center area or (b) in the same Office Park/Campus Environment or contiguous property, located in contiguous Serving Wire Center areas. It is available with all capacities of SMARTRing service (a.k.a. BellSouth SPA Dedicated Ring) except OC-1. This rate element does not apply where Customer Nodes are adjacently connected in the same building on the same SMARTRing service (a.k.a. BellSouth SPA Dedicated Ring) for the purpose of providing additional node capacity.

(9) Channel Interface Capacity Reallocation

Channel Interface Capacity Reallocation allows the customer to reallocate STS-1, DS3 and/or DS1 capacity interfaces at each node subsequent to the initial service installation.

(10) The SMARTRing service (a.k.a. BellSouth SPA Dedicated Ring) Rearrangement rate category applies when the customer adds BellSouth Customer Network Management Service options to an existing OC-1, OC-3, OC-3+ OC-12, OC-48, OC-48+, OC-192 or OC-192+ SMARTRing service (a.k.a. BellSouth SPA Dedicated Ring), installed on or after June 3, 1994. These charges do not apply when BellSouth Customer Network Management Service is added to an existing SMARTRing service (a.k.a. BellSouth SPA Dedicated Ring) installed prior to June 3, 1994, and the entire ring is being upgraded to a new SMARTRing service (a.k.a. BellSouth SPA Dedicated Ring) at the same time.

ACCESS SERVICE

7 - Special Access (a.k.a. BellSouth SPA) Service

7.1 General

7.1.3 Service Configurations

There are four types of service configurations over which Special Access (a.k.a. BellSouth SPA) services are provided: link service, two-point service, multipoint service, and SMARTRing service (a.k.a. BellSouth SPA Dedicated Ring).

A change from one Special Access (a.k.a. BellSouth SPA) Service configuration to another will be treated as a discontinuance of existing service and an installation of a new service as set forth in 5.6 of this guidebook, except for BellSouth SPA CNM - FlexServ Service reconfigurations service or link service configurations.

(A) Link Service

A link is a service configuration provided as a DS3 or DS1 channel of a LightGate service (a.k.a. BellSouth SPA Point to Point Network) local channel and/or interoffice channel. DS3 or DS1 channels provided in a LightGate service (a.k.a. BellSouth SPA Point to Point Network) interoffice channel must either be combined with corresponding DS3 or DS1 channels in a LightGate service (a.k.a. BellSouth SPA Point to Point Network) local channel system to form a single link, or they may be provided on a stand-alone link basis with BellSouth SPA CNM - FlexServ Service or SMARTRing service (a.k.a. BellSouth SPA Dedicated Ring).

Individual links may be installed, maintained in service, and subsequently disconnected without affecting other links connected to them. Disconnection of a link, which forms a part of a two-point service configuration, necessitates the disconnection of the non-link service elements in the two-point configuration also.

ACCESS SERVICE

7 - Special Access (a.k.a. BellSouth SPA) Service

7.1 General

7.1.3 Service Configurations

(A) Link Service

Applicable rate elements are:

- One LightGate service (a.k.a. BellSouth Point to Point Network) Local Channel and/or LightGate service (a.k.a. BellSouth Point to Point Network) Interoffice Channel
- Optional Features and Functions (when applicable).

(1) Synchronous Transport

The following diagram depicts Link service(s) connecting customer premises "A" with several locations.

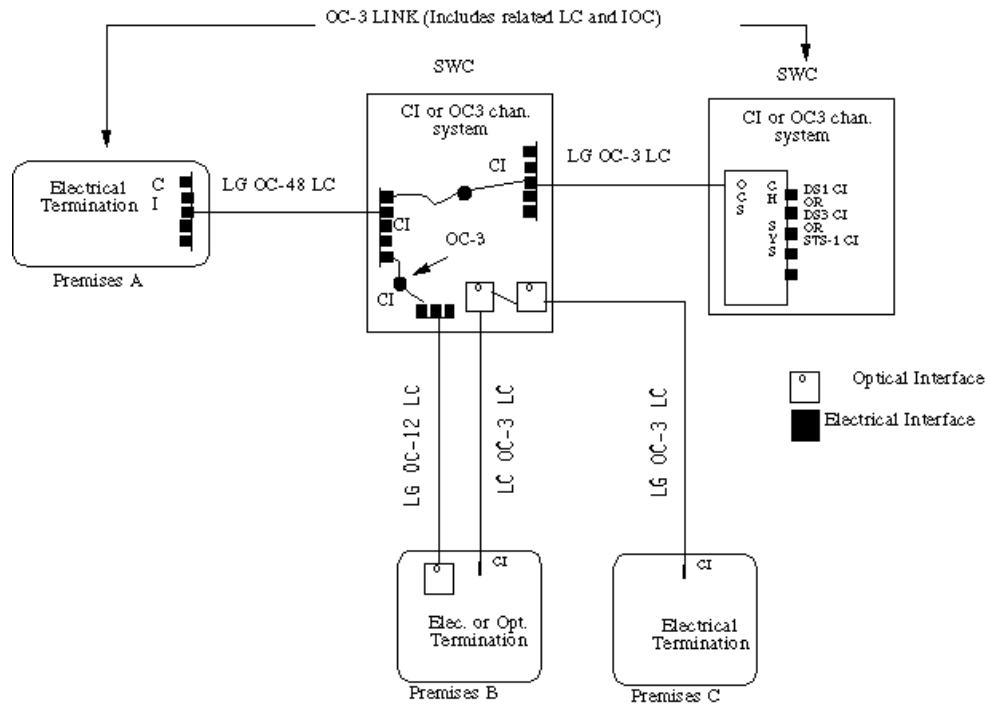

Rate elements applicable to this diagram are:

- Local Channels [LC] (OC-3 with opt. SWC termination, OC-12 opt. cust. termination, OC-48 electrical)
- Interoffice Channels [IOC] (OC-3)
- Electrical Channel Interface [CI] (OC-3)
- OC-3 Channel System [CS] (OC-3)
- Electrical Channel Interface [CI] (DS1)
- Electrical Channel Interface [CI] (DS3)
- Electrical Channel Interface [CI] (STS-1)

ACCESS SERVICE

7 - Special Access (a.k.a. BellSouth SPA) Service

7.1 General

7.1.3 Service Configurations

(B) Two-Point Service

A two-point service connects two customer designated premises, either on a directly connected basis, through a Hub where multiplexing functions are performed, or through BellSouth SPA CNM - FlexServ Service or an optional feature for BellSouth SPA CNM - FlexServ Service.

Applicable rate elements are:

- Local Channels
- Interoffice Channels (as applicable)
- Optional Features and Functions (when applicable)

In addition, a Special Access (a.k.a. BellSouth SPA) Surcharge and a Message Station Equipment Recovery Charge provided in this guidebook may be applicable.

ACCESS SERVICE

7 - Special Access (a.k.a. BellSouth SPA) Service

7.1 General

7.1.3 Service Configurations

(C) Multipoint Service

Multipoint service connects three or more customer designated premises through a BellSouth Hub. There is no limitation on the number of mid-links available with multipoint service. However, when more than three mid-links are provided in tandem, the quality of the service may be degraded. A mid-link is a channel between Hubs (i.e., bridging locations). Only certain types of Special Access (a.k.a. BellSouth SPA) service are provided as multipoint service. These are so designated in the Service Descriptions set forth in this guidebook.

Multipoint service utilizing a customized technical specifications package as set forth in this guidebook will be provided when technically possible. If BellSouth determines that the requested characteristics for a multipoint service are not compatible, the customer will be advised and given the opportunity to change the order.

When ordering, the customer will specify the desired bridging Hub(s) selected from National Exchange Carrier Association, Inc. Tariff F.C.C. No. 4. This tariff identifies the type(s) of bridging functions which are available and the serving wire centers at which they are available. (T)

Applicable Rate Elements are:

- Local Channels (one per customer designated premises)
- Interoffice Channels (as applicable between serving wire centers associated with two customer designated premises, between a serving wire center and a Hub, or between Hubs)
- Bridging
- Additional Optional Features (when applicable)

In addition, a Special Access (a.k.a. BellSouth SPA) Surcharge as set and a Message Station Equipment Recovery Charge as set forth in this guidebook may be applicable.

ACCESS SERVICE

7 - Special Access (a.k.a. BellSouth SPA) Service

7.1 General7.1.3 Service Configurations(D) SMARTRing Service (a.k.a. BellSouth SPA Dedicated Ring)

The SMARTRing service (a.k.a. BellSouth SPA Dedicated Ring) configuration utilizes a multi-nodal ring architecture which is specified jointly by the Telephone Company and the customer. The minimum configuration provides dedicated DS3 and/or DS1 digital services and must include at least three nodes. The three nodes may all be Central Office Nodes in Telephone Company Central Offices, or the three nodes may be a Central Office Node in a Telephone Company Central Office, a Customer Node at a customer's designated location and the third node may be either a Central Office Node or a node at another customer designated location. Additional nodes for either arrangement may be any combination thereof. The maximum number of nodes will be determined based on equipment capability. The nodes are connected by SMARTRing service (a.k.a. BellSouth SPA Dedicated Ring) Local Channels, Alternate Central Office Channels, Interoffice Channels and Internodal Channels as applicable. SMARTRing service (a.k.a. BellSouth SPA Dedicated Ring) may be connected to other DS3/DS1 services only at Central Office Nodes. With OC-12 SMARTRing service (a.k.a. BellSouth SPA Dedicated Ring) installed on or after June 3, 1994, and with OC-48 and OC-48+ SMARTRing service (a.k.a. BellSouth SPA Dedicated Ring) the customer may request an OC-1 and/or OC-3 Overlay Ring Arrangement riding the customer's host OC-12, OC-48, or OC-48+ SMARTRing service (a.k.a. BellSouth SPA Dedicated Ring). With OC-48 or OC-48+ SMARTRing service (a.k.a. BellSouth SPA Dedicated Ring), the customer may request an OC3+ and/or OC-12 Overlay Ring Arrangement riding the customer's host OC-48 SMARTRing service (a.k.a. BellSouth SPA Dedicated Ring). With OC-192+ SMARTRing service (a.k.a. BellSouth SPA Dedicated Ring), the customer may request an OC3+, OC-12, OC-48, and/or OC-48+ Overlay Ring Arrangement riding the customer's host OC-192+ SMARTRing service (a.k.a. BellSouth SPA Dedicated Ring). With OC-192 SMARTRing service (a.k.a. BellSouth SPA Dedicated Ring), the customer may request an OC3+, OC-12 and/or OC-48 Overlay Ring Arrangement riding the customer's host OC-192 SMARTRing service (a.k.a. BellSouth SPA Dedicated Ring). In an Overlay Ring Arrangement, node and channel configuration requirements apply to the host SMARTRing service (a.k.a. BellSouth SPA Dedicated Ring).

Applicable rate elements for this service are:

- Customer Node (at least one for configurations other than three Central Office Node arrangement)
- Customer Channel Interface (one for each originating/terminating activated DS1, DS3, STS-1, OC-3, OC-12, OC-48 and/or 1000 Mbps for each Customer Node)
- Central Office Node (at least one for configurations other than three Central Office Node arrangement)
- Central Office Channel Interface (one for each originating/terminating activated DS1, DS3, STS-1, OC-3 and/or OC-12, OC-48 and/or 1000 Mbps for each Central Office Node or one for each 28 DS1 Channel System and associated DS1 Channel Interfaces for each activated DS3)

ACCESS SERVICE

7 - Special Access (a.k.a. BellSouth SPA) Service

7.1 General

7.1.3 Service Configurations

(D) SMARTRing Service (a.k.a. BellSouth SPA Dedicated Ring)

Applicable rate elements for this service are:

- Local Channel
(at least one for each Customer Node which is directly connected to the serving wire center)
- Alternate Central Office Channel
(at least one for each Customer Node which is directly connected to an Alternate Central Office)
- Internodal Channel
(one for each path between two directly connected customer nodes)
- Interoffice Channel
(one for each path between each two directly connected Telephone Company Central Offices)
- Channel Interface Capacity Reallocation (one per node per occurrence)
- SMARTRing service (a.k.a. BellSouth SPA Dedicated Ring) Rearrangement (Surveillance, per Node, per SMARTRing service (a.k.a. BellSouth SPA Dedicated Ring) rearranged; Reconfiguration, per STS-1 group, per Node)

ACCESS SERVICE

7 - Special Access (a.k.a. BellSouth SPA) Service

7.1 General

7.1.3 Service Configurations

(D) SMARTRing Service (a.k.a. BellSouth SPA Dedicated Ring)

Example: SMARTRing service (a.k.a. BellSouth SPA Dedicated Ring) OC-3 capacity.

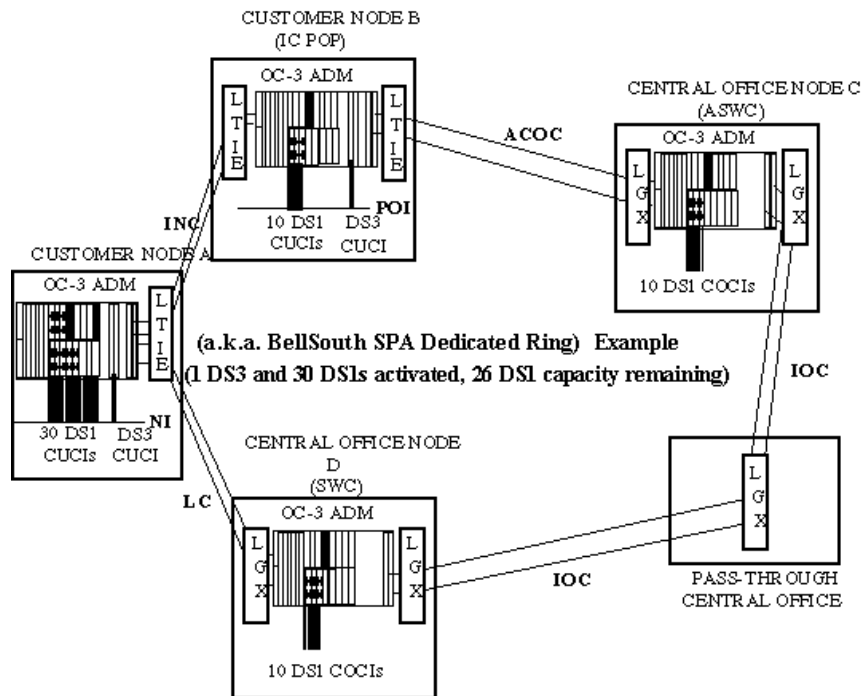

For this example the following rate elements are applicable:

- 2 Customer Nodes
- 2 Central Office Nodes
- 1 Local Channel
- 1 Internodal Channel
- 1 Alternate Central Office Channel
- 2 Interoffice Channels
- 2 DS3 Customer Channel Interfaces
- 40 DS1 Customer Channel Interfaces
- 20 DS1 Central Office Channel Interfaces

ACCESS SERVICE

7 - Special Access (a.k.a. BellSouth SPA) Service

7.1 General

7.1.3 Service Configurations

(D) SMARTRing Service (a.k.a. BellSouth SPA Dedicated Ring)

Example: SMARTRing service (a.k.a. BellSouth SPA Dedicated Ring) OC-12 capacity.

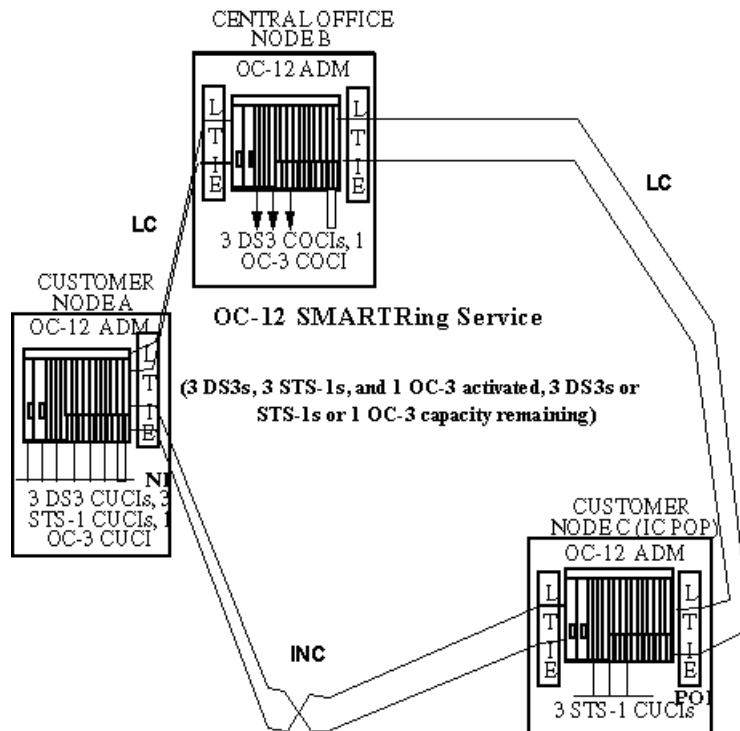

For this example the following rate elements are applicable:

- 2 Customer Nodes
- 1 Central Office Node
- 2 Local Channels
- 1 Internodal Channel
- 3 DS3 Customer Channel Interfaces
- 3 DS3 Central Office Channel Interfaces
- 6 STS-1 Customer Channel Interfaces¹
- 1 OC-3 Customer Channel Interface¹
- 1 OC-3 Central Office Channel Interface¹

* Note 1: Available with SMARTRing service (a.k.a. BellSouth SPA Dedicated Ring) installed on or after June 3, 1994.

ACCESS SERVICE

7 - Special Access (a.k.a. BellSouth SPA) Service

7.1 General

7.1.3 Service Configurations

(D) SMARTRing Service (a.k.a. BellSouth SPA Dedicated Ring)

Example: SMARTRing service (a.k.a. BellSouth SPA Dedicated Ring)
OC-3+ capacity.

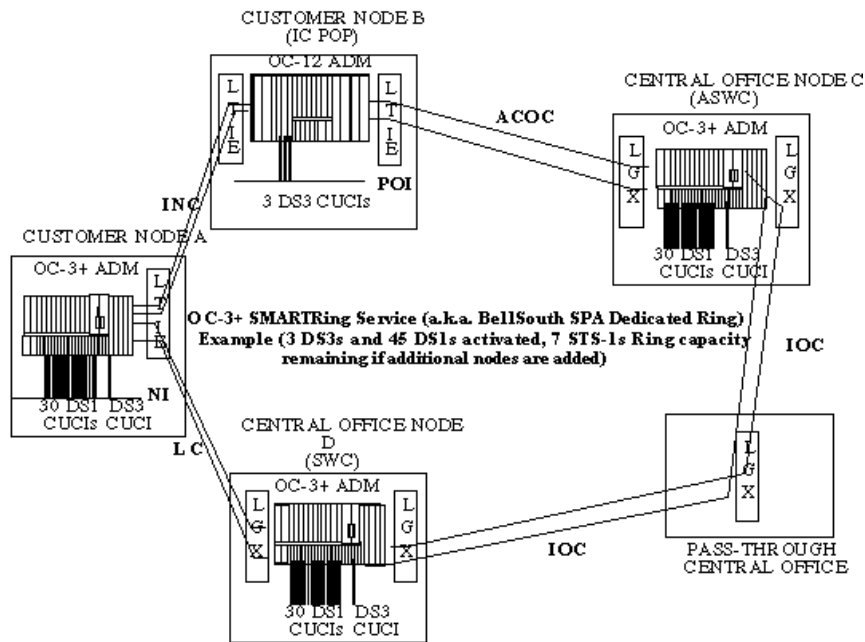

For this example the following rate elements are applicable:

- 2 Customer Nodes
- 2 Central Office Nodes
- 1 Local Channel
- 1 Internodal Channel
- 1 Alternate Central Office Channel
- 2 Interoffice Channels
- 4 DS3 Customer Channel Interfaces
- 2 DS3 Central Office Channel Interfaces
- 30 DS1 Customer Channel Interfaces
- 60 DS1 Central Office Channel Interfaces

ACCESS SERVICE

7 - Special Access (a.k.a. BellSouth SPA) Service

7.1 General

7.1.3 Service Configurations

(D) SMARTRing (a.k.a. BellSouth SPA Dedicated Ring) Service

Example: SMARTRing (a.k.a. BellSouth SPA Dedicated Ring) service OC-48 capacity.

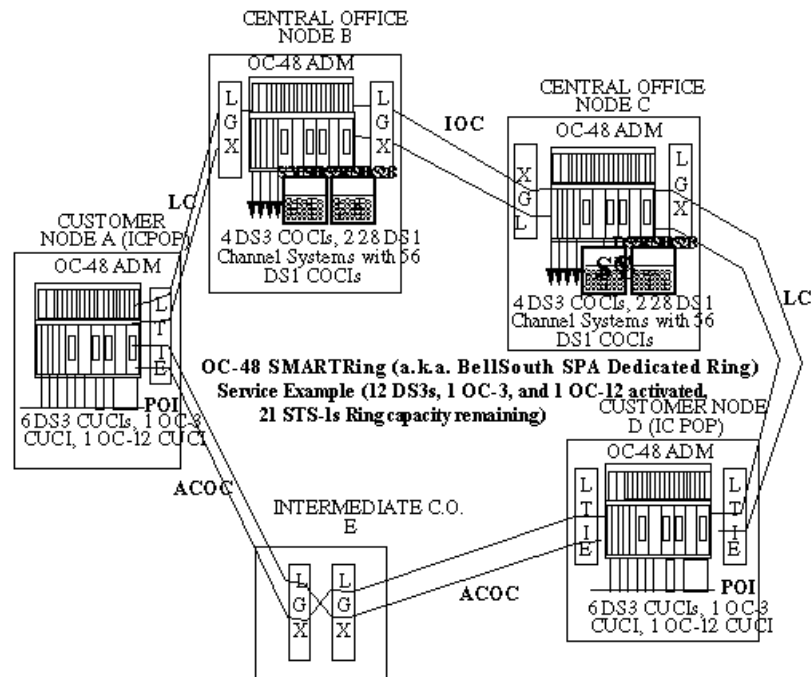

For this example the following rate elements are applicable:

- 2 Customer Nodes
- 2 Central Office Nodes
- 2 Local Channels
- 2 Alternate Central Office Channels
- 1 Interoffice Channel
- 12 DS3 Customer Channel Interfaces
- 8 DS3 Central Office Channel Interfaces
- 4 28 DS1 Channel Systems (DS3)
- 112 DS1 Central Office Channel Interfaces
- 2 OC-3 Customer Channel Interfaces
- 2 OC-12 Customer Channel Interfaces

ACCESS SERVICE

7 - Special Access (a.k.a. Bellsouth SPA) Service

7.1 General

7.1.3 Service Configurations

(D) SMARTRing Service (a.k.a. BellSouth SPA Dedicated Ring)

Example: SMARTRing service (a.k.a. BellSouth SPA Dedicated Ring) service OC-48+ capacity.

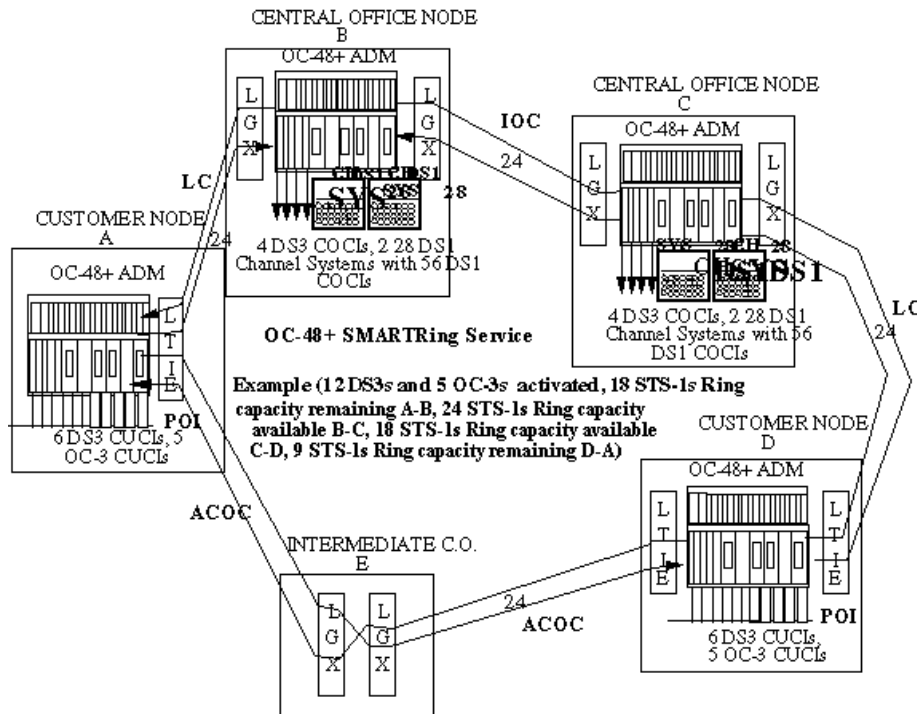

For this example the following rate elements are applicable:

- 2 Customer Nodes
- 2 Central Office Nodes
- 2 Local Channels
- 2 Alternate Central Office Channels
- 1 Interoffice Channel
- 12 DS3 Customer Channel Interfaces
- 8 DS3 Central Office Channel Interfaces
- 4 28 DS1 Channel Systems (DS3)
- 112 DS1 Central Office Channel Interfaces
- 10 OC-3 Customer Channel Interfaces

ACCESS SERVICE

7 - Special Access (a.k.a. BellSouth SPA) Service

7.1 General

7.1.4 Alternate Use

Alternate Use occurs when a service is arranged by the Telephone Company so that the customer can select different types of transmission at different times. A customer may use a service in any privately beneficial manner. However, where technical or engineering changes are required to effectuate an alternate use, the Telephone Company will make such special arrangements available on an individual case basis.

The arrangement required to transfer the service from one operation to the other (i.e., the transfer relay and control leads) will be rated and provided on an individual case basis. The customer will pay the stated guidebook rates for the Access Service rate elements for the service ordered (i.e., Local Channels, Interoffice Channels [as applicable] and Optional Features [if any]).

7.1.5 Design Layout Report

At the request of the customer, the Telephone Company will provide to the customer the make-up of the facilities and services provided under this guidebook as Special Access Service (a.k.a. BellSouth SPA) to aid the customer in designing its overall service. This information will be provided in the form of a Design Layout Report. The Design Layout Report will be provided to the customer at no charge, and will be reissued or updated whenever these facilities are materially changed.

7.1.6 Ordering Options and Conditions

The customer places an access order with the Telephone Company for the provision of Special Access (a.k.a. BellSouth SPA) service.

The options and conditions for access orders are set forth in detail in Section 5 of this guidebook. Also included in Section 5 are other charges that may be associated with ordering Special Access (a.k.a. BellSouth SPA) service (e.g., Service Date Change Charges, Cancellation Charges, etc.).

7.2 Reserved for Future Use

7.3 Reserved for Future Use

ACCESS SERVICE

7 - Special Access (a.k.a. BellSouth SPA) Service

7.4 General Rate Conditions

This section contains the specific conditions governing the rates and charges that apply for Special Access (a.k.a. BellSouth SPA) Service.

7.4.1 Types of Rates and Charges

There are three types of rates and charges. These are monthly rates, daily rates and nonrecurring charges. The rates and charges are described as follows:

(A) Monthly Rates

Monthly rates are flat recurring rates that apply each month or fraction thereof that a Special Access (a.k.a. BellSouth SPA) Service is provided. For billing purposes, each month is considered to have 30 days.

(B) Nonrecurring Charges

Nonrecurring charges are one-time charges that apply for specific work activity (i.e., installation or change to an existing service). The types of nonrecurring charges that apply for Special Access (a.k.a. BellSouth SPA) service are: installation of service, installation of optional features and functions, and service rearrangements.

The following list identifies the individual Special Access (a.k.a. BellSouth SPA) services provided under Section 7 of this guidebook which are eligible for credit of nonrecurring charges under "Service Installation Guarantee" found in Section 2.4.9. These services are not eligible for the Service Installation Guarantee when the requested installation, move or rearrangement of service interval is four days or less, as measured from the application date of the service order.

- High Capacity Service (a.k.a. BellSouth SPA High Capacity)
- SMARTRing (a.k.a. BellSouth SPA Dedicated Ring) service (Channel interfaces only)

Provided, however, that the following services are not eligible for such credit:

- Video (a.k.a. BellSouth SPA Video) services
- BellSouth Metro Ethernet Service

-

(D)

ACCESS SERVICE

7 - Special Access (a.k.a. BellSouth SPA) Service

7.4 General Rate Conditions

7.4.1 Types of Rates and Charges

(C) Nonrecurring Charges

(1) Installation of Service

(a) Local Channels

Nonrecurring charges apply to each Local Channel on each Special Access (a.k.a. BellSouth SPA) service installed. When First and Additional nonrecurring charges apply, they are assessed as follows: When one Local Channel is ordered and installed, it is billed at the First Service Installed charge. For the installation of local channels when more than one of the same type of service between the same locations, for the same customer, is ordered and installed at the same time; one at each location is billed at the First Service Installed charge and the others are billed at the Additional Service Installed charge. Future service requests for the same access services, at a later date, will be treated as new orders and nonrecurring charges for first service and additional service will again apply. For all video services, one nonrecurring charge applies for each Local Channel.

For LightGate service (a.k.a. BellSouth SPA Point to Point Network), one nonrecurring charge applies for each system, SAFT I or II option, and channel interface.

(b) Interoffice Channel

The nonrecurring charge for the Interoffice Channel will be applied each time the Interoffice Channel rate element is applicable. For LightGate service (a.k.a. BellSouth SPA Point to Point Network), one nonrecurring charge applies for each system and each channel interface.

The Nonrecurring charges for the Installation of Service are set forth in Section 7, Part 11 of this guidebook as Nonrecurring Charges for the Local Channel Rate Element and the Interoffice Channel Rate Element.

ACCESS SERVICE

7 - Special Access (a.k.a. BellSouth SPA) Service

7.4 General Rate Conditions

7.4.1 Types of Rates and Charges

(C) Nonrecurring Charges

(2) Installation of Optional Features and Functions

Nonrecurring charges apply to the installation of Optional Features and Functions available with Special Access (a.k.a. BellSouth SPA) service. The Initial nonrecurring charge applies if the feature or function is installed coincident with the primary service. The Subsequent nonrecurring charge applies if the feature or function is installed after the installation of the primary service.

First and Additional nonrecurring charges are applicable to activate each individual Central Office Channel Interface of a Basic Channelization System, and are in addition to the nonrecurring charges for the Basic Channelization System. A "First" nonrecurring Central Office Channel Interface nonrecurring charge is applicable to the first Channelization Feature installed coincident with the installation of a Basic Channelization System, per service request. An "Additional" nonrecurring charge applies for each additional Central Office Channel Interface, of the same type, ordered and installed at the same location, for the same customer, at the same time, on the same order request. Future requests for a Central Office Channel Interface(s) on an existing Basic Channelization System will be treated as new requests and will require "First" and "Additional" Central Office Channel Interface nonrecurring charge application, in addition to any other applicable charges.

The nonrecurring charges for the installation of Optional Features and Functions are set forth in Section 7.5, Part 11 of this guidebook as nonrecurring charges for Optional Features and Functions associated with the specific services.

ACCESS SERVICE

7 - Special Access (a.k.a. BellSouth SPA) Service

7.4 General Rate Conditions

7.4.1 Types of Rates and Charges

(C) Nonrecurring Charges

(3) Service Rearrangements

Service rearrangements are changes to existing (installed) services which do not result in either a change in the minimum period requirements as set forth in Part 3, Section 5.6(E) of this guidebook or a change in the physical location of the point of the termination at a customer designated premises. Changes which result in the establishment of new minimum period obligations are treated as disconnects and starts. Changes in the physical location of the point of the termination are treated as moves and are described and charged for as set forth in Section 7.4.5. A change which results from a transfer of service is described and charged as set forth in Section 7.4.1(C) (4) and Part 11, Section 7.5.12 of this guidebook. (T)

The charge to the customer for the service rearrangement is dependent on whether the change is administrative only in nature or involves actual physical change to the service. (T)

ACCESS SERVICE

7 - Special Access (a.k.a. BellSouth SPA) Service

7.4 General Rate Conditions

7.4.1 Types of Rates and Charges

(C) Nonrecurring Charges

(3) Service Rearrangements

Administrative changes, as identified below, will be made without charge to the customer. Such changes require the continued provision and billing of the Access Service to the same entity (i.e., customer remains responsible for all outstanding indebtedness for the Access Service). Administrative changes are as follows:

- Change of customer name (i.e., the customer of record does not change but rather the customer of record changes its name -- e.g., AT&T-Long Lines to AT&T-Communications),
- Change of customer or customer's end user premises address when the change of address is not a result of a physical relocation of equipment,
- Change in billing data (name, address, or contact name or telephone number. The customer of record does not change),
- Change of customer circuit identification,
- Change of billing account number,
- Change of customer test line number,
- Change of customer or customer's end user contact name or telephone number, and
- Change of jurisdiction.

All other service rearrangements, including physical changes to existing services, will be charged for as follows:

- If the change involves the addition of other customer designated premises to an existing multipoint service, the nonrecurring charge for the local channel rate element(s) being added will apply. Nonrecurring charges for interoffice channel mileage may also apply.
- If the change involves the addition of other customer designated premises to an existing two-point service, resulting in a multipoint circuit configuration, the nonrecurring charge for the local channel rate element(s) being added will apply. Nonrecurring charges for interoffice channel mileage may also apply.
- If the change involves the disconnection of customer designated premises from an existing multipoint circuit resulting in a two-point circuit configuration, no charges will apply.
- If the change involves the addition of an optional feature or function which has a separate nonrecurring charge, that nonrecurring charge will apply.

ACCESS SERVICE

7 - Special Access (a.k.a. BellSouth SPA) Service

7.4 General Rate Conditions

7.4.1 Types of Rates and Charges

(C) Nonrecurring Charges

(3) Service Rearrangements

- If the change involves changing (reconfiguring) an existing BellSouth Metro Ethernet Service Connection, appropriate charges provided in Section 7 of this guidebook.
- If the change involves the addition of a DS3 Network Interface Unit (NIU) to a LightGate service (a.k.a. BellSouth SPA Point to Point Network) or SMARTRing service (a.k.a. BellSouth SPA Dedicated Ring), the rates and charges for the NIU shall apply in addition to applicable SPA DS3 Service Date Advancement and SPA DS3 Service Date Advancement - Missed Appointment rates and charges as shown in Part 3, Section 5.1 of this guidebook. (T)
- For all other changes, including the addition of optional features without separate nonrecurring charges, a charge equal to a Local Channel rate element nonrecurring charge will apply. When more than one Local Channel of the same type is rearranged in the same manner at the same time between the same locations, for the same customer, the first Local Channel rearranged is billed at the First Service Installed charge and the other Local Channels are billed Additional Service Installed charges. Only one such charge will apply per service termination, per change.

ACCESS SERVICE

7 - Special Access (a.k.a. BellSouth SPA) Service

7.4 General Rate Conditions

7.4.1 Types of Rates and Charges

(C) Nonrecurring Charges

(4) Transfer of Service

When a change in billing data (e.g., name, address, contact name, or telephone number) is requested in association with a change in the customer of record, transfer of service charges, as set forth in Section 7, Part 11 of this guidebook will apply. Charges are applied on a Billing Account Number (BAN) and per circuit basis.

⁽¹⁾ Previous material in this section has been de-tariffed pursuant to the Commission's Wireline Broadband Order in CC Docket Nos. 02-33 and 01-337, released September 23, 2005.

Generally available terms and conditions associated with the de-tariffed service is available at www.att.com/products.

ACCESS SERVICE

7 - Special Access (a.k.a. BellSouth SPA) Service

7.4 General Rate Conditions

7.4.2 Surcharge for Special Access (a.k.a. BellSouth SPA) Service

(A) General

In addition to the rates and charges described in Section 7.4.1, there is a monthly surcharge that applies to Special Access (a.k.a. BellSouth SPA) service.* The Special Access (a.k.a. BellSouth SPA) Surcharge compensates the Telephone Company for use of the local exchange network when Special Access (a.k.a. BellSouth SPA) service is connected to a PBX or equivalent device which is capable of interconnecting the Special Access (a.k.a. BellSouth SPA) service with local exchange service. (T)

The Telephone Company will automatically bill the surcharge on each Special Access (a.k.a. BellSouth SPA) service installed irrespective of whether the interconnection capability exists in the customer's premises equipment or in a Centrex Type Services switch unless written certification is received from the customer certifying exemption status as set forth in Section 7.4.2(B). (T)

(B) Special Access (a.k.a. BellSouth SPA) Surcharge Exemptions

The Special Access service will be exempted from the surcharge if the customer provides the Telephone Company written certification that the Special Access (a.k.a. BellSouth SPA) service termination is one of the following:

- (1) an open-end termination in a Telephone Company switch of an FX line, including CCSA and CCSA-equivalent ONALS; or
- (2) an analog Local Channel that is used for radio or television program transmission; or
- (3) a termination used for TELEX service; or

* Effective June 1, 1986, Special Access (a.k.a. BellSouth SPA) Surcharge Conditions apply to Special Access (a.k.a. BellSouth SPA) used for WATS Access Lines (a.k.a. BellSouth SPA WATS Lines). On that date, the Telephone Company will begin to bill such surcharge for Special Access (a.k.a. BellSouth SPA) facilities used for WATS Access Lines (a.k.a. BellSouth SPA WATS Lines) presently in service. Payment of any Special Access (a.k.a. BellSouth SPA) Surcharge billed on Special Access (a.k.a. BellSouth SPA) facilities used for WATS Access Lines (a.k.a. BellSouth SPA WATS Lines) in service as of June 1, 1986, may be deferred, without penalty, for up to ninety (90) days from the date of the first bill rendered for such Special Access (a.k.a. BellSouth SPA) Surcharge.

ACCESS SERVICE

7 - Special Access (a.k.a. BellSouth SPA) Service

7.4 General Rate Conditions

7.4.2 Surcharge for Special Access (a.k.a. BellSouth SPA) Service

(B) Special Access (a.k.a. BellSouth SPA) Surcharge Exemptions

- (4) a termination that by the nature of its operating characteristics could not make use of Telephone Company common lines; or
- (5) a termination that interconnects either directly or indirectly to the local exchange network where the usage is subject to Carrier Common Line charges* such as, where the Special Access (a.k.a. BellSouth SPA) service accesses only BellSouth SWA FGA and no local exchange lines, or Special Access (a.k.a. BellSouth SPA) service between customer points of termination or Special Access (a.k.a. BellSouth SPA) service connecting CCSA or CCSA-type equipment (inter-machine trunks); or
- (6) a termination that the customer certifies to the Telephone Company is not connected to a PBX or other device capable of interconnecting the special access facility to a local exchange subscriber line.

(C) Exemption Certification

- (1) Special Access (a.k.a. BellSouth SPA) services, which are terminated as set forth in Section 7.4.2(B), will be exempted from the Special Access (a.k.a. BellSouth SPA) Surcharge if the customer provides the Telephone Company with a written notification certifying exemption. Such notification shall be provided by the customer (1) at the time the Special Access (a.k.a. BellSouth SPA) service is ordered or installed; (2) at such time as the Special Access (a.k.a. BellSouth SPA) service is reterminated to a device not capable of interconnecting to the local exchange network, or (3) at such time as the Special Access (a.k.a. BellSouth SPA) service becomes associated with a BellSouth SWA service that is subject to Carrier Common Line charges. (T)

* Resellers of WATS Access Line (a.k.a. BellSouth SPA WATS Line) Service may be exempted from paying CCL Charges during the transition period of June 1, 1986 to January 1, 1987. However, they should not be assessed any Special Access (a.k.a. BellSouth SPA) Surcharge on the closed end. (T)

ACCESS SERVICE

7 - Special Access (a.k.a. BellSouth SPA) Service

7.4 General Rate Conditions

7.4.2 Surcharge for Special Access (a.k.a. BellSouth SPA) Service

(C) Exemption Certification

- (2) If written certification is not received at the time the Special Access (a.k.a. BellSouth SPA) service is obtained, the surcharge will be applied. Exempt status will become effective on the certification date indicated by the customer, subject to the conditions in Section 7.4.2(D). (T)
- (3) The exemption certification is to be provided by the customer ordering the service. The certification must be signed by the customer or authorized representative and include the category of exemption, as set forth in Section 7.4.2(B), for each termination, and the date which the exemption is effective. (T)
- (4) The customer shall also notify the Telephone Company when an exempted Special Access (a.k.a. BellSouth SPA) service is changed or reterminated such that the exemption is no longer applicable.

(D) Crediting the Surcharge

The Telephone Company will cease billing the Special Access (a.k.a. BellSouth SPA) Surcharge when certification that the Special Access (a.k.a. BellSouth SPA) service has become exempt from the surcharge, as set forth in (B) preceding is received. If the status of the Special Access (a.k.a. BellSouth SPA) service was changed prior to receipt for the exemption certification, the Telephone Company will credit the customer's account, not to exceed ninety (90) days, based on the effective date of the change specified by the customer in the letter of certification.

(E) Application of Rates

- (1) The monthly Special Access (a.k.a. BellSouth SPA) Surcharge applies to Special Access (a.k.a. BellSouth SPA) services arranged, as set forth in Section 7.4.2(A), on a per voice equivalent basis as shown in the following example. (T)

ACCESS SERVICE

7 - Special Access (a.k.a. BellSouth SPA) Service

7.4 General Rate Conditions

7.4.2 Surcharge for Special Access (a.k.a. BellSouth SPA) Service

(E) Application of Rates

(1) (Cont'd)

<u>Special Access Service</u>	<u>Voice Grade Equivalent</u>		<u>Surcharge</u>	<u>Monthly Charge</u>
Voice Grade (a.k.a. BellSouth SPA DSO VG)	1	X	\$25.00	\$ 25.00
Wideband Analog (a.k.a. BellSouth SPA Wideband Analog) Group Level	12	X	\$25.00	\$300.00
DS1	24	X	\$25.00	\$600.00

(2) In the case of multipoint Special Access (a.k.a. BellSouth SPA) service, one Special Access (a.k.a. BellSouth SPA) Surcharge will apply for each termination at a customer designated premises except that no surcharge applies at the customer designated premises at which the Access Service is connected to Interstate Service.

(3) The Telephone Company will bill the surcharge to the customer who orders the Special Access (a.k.a. BellSouth SPA) service unless the Service is exempt as set forth in Section 7.4.2(B). The rate for the Special Access (a.k.a. BellSouth SPA) Surcharge is set forth in Part 11, Section 7.5 of this guidebook.

(T)
(T)

7.4.3 Message Station Equipment Recovery Charge*

The Message Station Equipment Recovery Charge is a charge to recover that portion of message station equipment that is assigned to Special Access (a.k.a. BellSouth SPA) service.

* Effective June 1, 1986, Special Access (a.k.a. BellSouth SPA) Message Station Equipment Recovery charges apply to WATS Access Lines (a.k.a. BellSouth SPA WATS Lines). On that date, the Telephone Company will begin to bill such charges for Special Access (a.k.a. BellSouth SPA) facilities used for WATS Access Lines (a.k.a. BellSouth SPA WATS Lines) presently in service. Payment of any message Station Equipment Recovery Charge billed on Special Access (a.k.a. BellSouth SPA) facilities used for WATS Access Lines (a.k.a. BellSouth SPA WATS Lines) in service as of June 1, 1986, may be deferred, without penalty, for up to ninety (90) days from the date of the first bill rendered for such message Station Equipment Recovery Charge.

ACCESS SERVICE

7 - Special Access (a.k.a. BellSouth SPA) Service

7.4 General Rate Conditions

7.4.3 Message Station Equipment Recovery Charge

Pursuant to CC Docket 83-1145 Memorandum Opinion and Order adopted by the Federal Communications Commission on November 8, 1984 and released on November 9, 1984, this charge is assessed only to those customers to which the Special Access (a.k.a. BellSouth SPA) Surcharge applies. The rate for the Message Station Equipment Recovery Charge is set forth in Part 11, Section 7.5 of this guidebook.

(T)
(T)

7.4.4 Minimum Periods

The minimum service period for all services is one month except as specified following. The minimum service period for SMARTRing service (a.k.a. BellSouth SPA Dedicated Ring) is four months. The minimum service periods for LightGate service (a.k.a. BellSouth SPA Point to Point Network) are specified in Part 11, Section 7.4.9 of this guidebook.

(T)

ACCESS SERVICE

7 - Special Access (a.k.a. BellSouth SPA) Service

7.4 General Rate Conditions7.4.5 Moves

A move involves a change in the physical location of one of the following:

- The Point of Termination at the customer's premises
- The customer's premises

The charges for the move are dependent on whether the move is to a new location within the same building or to a different building.

(A) Moves Within the Same Building

When a service is moved to a new location within the same building, the charge for the move will be an amount equal to one-half of the first service installed nonrecurring charge for the service termination affected. When a group of like services is moved to the same location inside a customer premises at the same time, the appropriate charges will be: one-half the first service installed nonrecurring charge for the first service moved of the group; and one-half the additional service installed nonrecurring charge for additional like services of that group. There will be no change in the minimum period requirements.

(B) Moves To a Different Building

Moves to a different building (customer premises) in a wire center serving area different than the customer's existing serving wire center serving area will be treated as a discontinuance and start of service and all associated nonrecurring charges will apply. Service will not be available simultaneously at both the original and new customer locations. New minimum period requirements may be established for the rearranged services in accordance with the conditions for a service. The customer will also remain responsible for satisfying all outstanding minimum period charges for the original service locations. When the move involves a multipoint service, the nonrecurring charge will apply per rate element affected.

Moves to a Telephone Company-provided BellSouth Expanded Interconnection Service arrangement, where the customer's and interconnector's existing wire center is the same, will be treated as a service move rather than a discontinuance and start of service. Cross Connect rates, nonrecurring charges, and optional feature and function charges in Section 13 of this guidebook will apply. In addition, service reconfiguration charges are applicable per customer request and per circuit moved as contained in this guidebook. Individual services will not be available simultaneously at both the original premises location and new wire center interconnection space. Additional cooperative end-to-end testing is available and will be conducted by the Telephone Company when requested at rates and charges contained in Section 13 of this guidebook. New minimum period requirements may be established for the rearranged services in accordance with the conditions for a service. The customer will remain responsible for satisfying all outstanding minimum period charges for the original service locations. When the move involves a multipoint service, the nonrecurring charge will apply per rate element affected.

ACCESS SERVICE

7 - Special Access (a.k.a. BellSouth SPA) Service

7.4 General Rate Conditions

7.4.5 Moves

(B) Moves To a Different Building

Moves to a different building (customer premises) in the customer's existing serving wire center serving area will be treated as a service move rather than a discontinuance and start of service. Nonrecurring charges for the new local channel will apply as well as any optional feature and function charges for that local channel. In addition, service reconfiguration charges are applicable per customer request and circuit moved as contained in Part 11, Section 7.5 of this guidebook. (T)
Service will not be available simultaneously at both the original and new customer locations. Additional cooperative end-to-end testing is available and will be conducted by the Telephone Company at a customer's request at rates and charges contained in Section 13.3.5(B). (T)
New minimum period requirements may be established for the rearranged services in accordance with the conditions for a service. The customer will also remain responsible for satisfying all outstanding minimum period charges for the original service locations. When the move involves a multipoint service, the nonrecurring charge will apply per rate element affected.

7.4.6 Mileage Measurement

Except as noted, the mileage to be used to determine the monthly rate for the Interoffice Channel is calculated on the airline distance between the locations involved, i.e., the serving wire centers associated with two customer-designated premises, a serving wire center associated with a customer-designated premises and a Telephone Company Hub or two Telephone Company Hubs. The serving wire center associated with a customer-designated premises is the serving wire center from which the customer-designated premises would normally obtain dial tone.

When service is provided from an alternate serving wire center, as described in Section 7.2.9(A), interoffice mileage is calculated on the airline distance from or to the alternate serving wire center in lieu of the wire center from which the customer-designated premises would normally receive dial tone. (T)

ACCESS SERVICE

7 - Special Access (a.k.a. BellSouth SPA) Service

7.4 General Rate Conditions

7.4.6 Mileage Measurement

Mileage is shown in Part 11, Section 7.5 of this guidebook in terms of mileage bands. To determine the rate to be billed, first compute the mileage using the V&H coordinates method, as set forth in National Exchange Carrier Association, Inc. Tariff F.C.C. No. 4, then find the band into which the computed mileage falls and apply the rates shown for that band. When the calculation results in a fraction of a mile, always round up to the next whole mile before determining the mileage band and applying the rates. (T)

When Hubs are involved, either due to customer-specified bridging or channelization or for the specific provisioning of a service, mileage is computed and rates applied separately for each section of the Interoffice Channel, i.e., customer designated premises serving wire center to Hub, Hub to Hub and/or Hub to customer designated premises serving wire center. Hubs are not utilized as interoffice channel mileage measurement points where the Telephone Company chooses to route the service through a Hub for other purposes. (T)

SMARTRing service (a.k.a. BellSouth SPA Dedicated Ring) Local Channel, Alternate Central Office Channel and Internodal Channel rates are also distance sensitive. They are measured per quarter airline mile or fraction thereof from the customer's designated premises to the Serving Wire Center, Alternate Central Office, or other Customer Nodes. V&H coordinates are derived for each customer location through the use of longitude and latitude measurements. Using the V&H coordinate method as set forth in National Exchange Carrier Association, Inc. Tariff F.C.C. No. 4, compute the mileage, convert to quarter miles, and multiply the appropriate per quarter mile rate by the distance involved. Any portion of a quarter mile will always round up to the next quarter mile before determining the mileage and applying the rate. (T)

The SMARTRing service (a.k.a. BellSouth SPA Dedicated Ring) Interoffice Channel mileage is calculated per quarter airline mile between two directly connected central office's on the ring. Interoffice Channel mileage is computed by using the V&H coordinates method as set forth in National Exchange Carrier Association, Inc. Tariff F.C.C. No. 4. To determine the rate to be billed, multiply the appropriate per quarter mile rate by the distance involved. Fractions of a quarter mile always round up to the next quarter mile before determining the mileage and applying the rate. (T)

ACCESS SERVICE

7 - Special Access (a.k.a. BellSouth SPA) Service

7.4 General Rate Conditions

7.4.6 Mileage Measurement

LightGate service(a.k.a. BellSouth SPA Point to Point Network) local channel system and SAFT Levels I and II monthly rates are distance sensitive and are measured per half airline mile, or fraction thereof, from a customer's serving wire center to the customer's designated premises. This mileage is developed by the Telephone Company in a multi-step process. Initially, the customer's street address location is taken and converted into its geographic coordinates of latitude and longitude utilizing the United States Government's land based, postal, geographic registration data base (TIGER). Precise determination of location is assured thru the use of specific postal address numbers, county, town, zip code, telephone area code and NXX information, CLLI information where available, and also known distances to street intersections if necessary. The specific mapping process from street address to corresponding latitude - longitude is available and may be obtained by requesting TIGER data from the Bureau of Census, Washington, D.C. 20233.

Following this, a customer's latitude and longitude are converted to V&H coordinates utilizing the standard algorithm calculation method originally developed by Bell Laboratories and currently used for interoffice mileage calculations in this guidebook. The calculation process converts latitude and longitude geographic points, based upon the ellipsoidal shape of the earth, and maps them to the planar map of the V&H Coordinate system that is used for standard mileage measurements. Detailed information regarding the specific equations utilized in this process are available from BELLCORE, Attn.: Executive Director - Language Standards, Room RRC4A801, 444 Hoes Lane, Piscataway, N.J. 08854.

The final step of the mileage calculation process utilizes the V&H coordinates of the customer's location and the Telephone Company's serving wire center to compute the airline mileage. The mileage is calculated using the method as set forth in National Exchange Carrier Association, Inc. Tariff F.C.C. No. 4. Any portion of a half mile will always round up to the next half mile before determining the mileage and applying the rate. (T)
(T)

ACCESS SERVICE

7 - Special Access (a.k.a. BellSouth SPA) Service

7.4 General Rate Conditions

7.4.6 Mileage Measurement

Local channel system mileage rates are calculated by multiplying the monthly rate per additional half mile by the number of additional half miles, not including the initial half mile of facilities included in the system rate. SAFT Levels I and II mileage rates are in addition to the local channel mileage rates preceding and are calculated by multiplying the monthly rate per half mile by the number of half miles, including the initial half mile of protection facilities. Information about local channel mileage and associated mileage charges will be provided by the Telephone Company without incurring any service obligations. Mileage for local channel systems is computed and rates applied separately from interoffice channels.

ACCESS SERVICE

7 - Special Access (a.k.a. BellSouth SPA) Service

7.4 General Rate Conditions

7.4.7 Facility Hubs

A customer has the option of ordering digital high capacity facilities (i.e., STS-1, OC-3, OC-12, OC-48, or OC-192) to a facility Hub for channelizing to individual services requiring lower capacity facilities.

Different locations may be designated as Hubs for different facility capacities, e.g., channelization from digital to digital may occur at one location while channelization from digital to analog may occur at a different location. When ordering, the customer will specify the desired channelization Hub(s) selected from National Exchange Carrier Association, Inc. Tariff F.C.C. No. 4. This guidebook identifies the type(s) of channelization functions which are available and the serving wire centers at which they are available. (T)
(T)

Some of the types of channelization available include the following:

- from higher to lower bit rate
- from higher to lower bandwidth
- from digital to voice frequency channels

End to end services may be provided on channels of these facilities to a Hub. The transmission performance for the end to end service provided between customer designated premises will be that of the lower capacity or bit rate.

The Telephone Company will commence billing the monthly rate for the facility to the Hub on the date specified by the customer on the service order. Individual services utilizing these facilities may be installed coincident with the installation of the facility to the Hub or may be ordered and/or installed at a later date, at the option of the customer. The customer will be billed for a high capacity digital Local Channel, Interoffice Channel (when applicable) and the Basic Channelization System at the time the facility is installed. DS1 and DS0 Basic Channelization Systems require a Central Office Channel Interface for activation of each lesser capacity channel. Individual service rates (by service type) will apply for a Local Channel, Central Office Channel Interface(s), and/or an additional Interoffice Channel (as required) for each channelized service. These will be billed to the customer as each individual service is installed.

ACCESS SERVICE

7 - Special Access (a.k.a. BellSouth SPA) Service

7.4 General Rate Conditions

7.4.7 Facility Hubs

Cascading channelization occurs when a high capacity (a.k.a. BellSouth SPA High Capacity) digital channel is channelized to provide channels with a lesser capacity and one of the lesser capacity channels is further channelized.

When cascading channelization is performed, whether in the same or a different Hub, a charge for the additional Basic Channelization System and Central Office Channel Interface(s) also applies. When cascading channelization is performed at different Hubbing locations, Interoffice Channel charges also apply between the Hubs.

7.4.8 Shared Use Analog and Digital High Capacity (a.k.a. BellSouth SPA High Capacity) Services

Shared use occurs when Special Access (a.k.a. BellSouth SPA) service and BellSouth SWA service are provided over the same Wideband Analog (a.k.a. BellSouth SPA Wideband Analog) or High Capacity (a.k.a. BellSouth SPA High Capacity) facilities through a common interface.

ACCESS SERVICE

7 - Special Access (a.k.a BellSouth SPA) Service

7.4 General Rate Conditions

7.4.8 Shared Use Analog and Digital High Capacity (a.k.a. BellSouth SPA High Capacity) Services

When the customer orders Special Access (a.k.a BellSouth SPA) Service, the facilities will be rated as Special Access (a.k.a BellSouth SPA) Service (i.e., Local Channel, Interoffice Channel, as appropriate, and Basic Channelization System and Central Office Channel Interface(s), if applicable) until such time as the customer chooses to use a portion of the available capacity for providing BellSouth SWA service. When individual channels are activated for BellSouth SWA service, the Special Access (a.k.a BellSouth SPA) Local Channel rates, Interoffice Channel rates, and Basic Channelization System rates, if applicable, will be reduced via a reduction factor. The reduction factor will be developed using the net number of BellSouth SWA services provided over a Special Access (a.k.a BellSouth SPA) Service facility at the beginning of a monthly billing period. For LightGate service (a.k.a. BellSouth SPA Point to Point Network) synchronous systems, the reduction factor is calculated by dividing the sum of the BellSouth SWA channels by the sum of the equivalent voice grade (a.k.a. BellSouth SPA DSO VG) capacity of the LightGate service (a.k.a. BellSouth SPA Point to Point Network) local channel or interoffice channel system. The reduction factor for LightGate service (a.k.a. BellSouth SPA Point to Point Network) channel interface rates, DS1 local channel rates, DS1 interoffice channel rates, and multiplexer rates is developed by dividing the sum of the BellSouth SWA channels by the voice grade (a.k.a. BellSouth SPA DSO VG) equivalent capacity of the interface, channel, or multiplexer as appropriate. The reduction factor's fraction is rounded off to four decimal places and then multiplied against the appropriate monthly recurring charges to determine the reduction amount.

ACCESS SERVICE

7 - Special Access (a.k.a. BellSouth SPA) Service

7.4 General Rate Conditions

7.4.8 Shared Use Analog and Digital High Capacity (a.k.a. BellSouth SPA High Capacity) Services

The capability exists for a customer to utilize all or part of a SMARTRing service (a.k.a. BellSouth SPA Dedicated Ring) to transport switched access provided the SMARTRing service (a.k.a. BellSouth SPA Dedicated Ring) channel interface transporting the BellSouth SWA service does not have BellSouth Customer Network Management Service capability as described in Section 7.2.11(A). The customer must place an order for each individual BellSouth SWA Channel provided over Special Access (a.k.a. BellSouth SPA) service Shared Use Facilities and specify the channel assignment for each such service. The switched traffic would enter and exit the SMARTRing service (a.k.a. BellSouth SPA Dedicated Ring) at Customer and Central Office Nodes on that network. When this occurs, ratcheting of Special Access (a.k.a. BellSouth SPA) rate elements (i.e. Nodes, Channel Interfaces, Local Channels, Alternate Central Office Channels, Internodal Channels, or Interoffice Channels) will be based on the number of voice grade (a.k.a. BellSouth SPA DSO VG) equivalent trunks/lines of that rate element used for BellSouth SWA access. Reduction factors will be developed to reduce the charges on system level billing as well as the billing on individual DS1, DS3, STS-1, OC-3, and/or OC-12 Channel Interfaces. For ratcheting purposes, the system level charges include Customer Nodes, Central Office Nodes, Local Channels, Alternate Central Office Channels, Internodal Channels, and Interoffice Channels as appropriate to make up a customer's SMARTRing service (a.k.a. BellSouth SPA Dedicated Ring). Individual OC-1, OC-3 and OC-12 Channel Interfaces used in Overlay Ring Arrangements will be ratcheted as system level charges. The system reduction factor will apply to the system level charges. (T)
(D)

The system reduction factor will be derived by dividing the number of activated BellSouth SWA access circuits by the voice grade (a.k.a. BellSouth SPA DSO VG) channel equivalent capacity of the self-healing ring. An OC-1 SMARTRing service (a.k.a. BellSouth SPA Dedicated Ring) has 672 voice grade (a.k.a. BellSouth SPA DSO VG) equivalent channels. An OC-3 SMARTRing service (a.k.a. BellSouth SPA Dedicated Ring) has 2,016 voice grade (a.k.a. BellSouth SPA DSO VG) equivalent channels. An OC-3+ or OC-12 SMARTRing service (a.k.a.

ACCESS SERVICE

7 - Special Access (a.k.a. BellSouth SPA) Service

7.4 General Rate Conditions

7.4.8 Shared Use Analog and Digital High Capacity (a.k.a. BellSouth SPA High Capacity) Services

BellSouth SPA Dedicated Ring) has 8,064 voice grade equivalent channels. An OC-48 SMARTRing service (a.k.a. BellSouth SPA Dedicated Ring) or OC-48+ SMARTRing service (a.k.a. BellSouth SPA Dedicated Ring) with 48 or less activated DS3s has 32,256 voice grade (a.k.a. BellSouth SPA DSO VG) equivalent channels. However, when an OC-48+ SMARTRing service (a.k.a. BellSouth SPA Dedicated Ring) is used to transport BellSouth SWA service, and more than 48 equivalent DS3s are activated on the service, the factor will be based upon the actual number of activated DS3s times 672 DSOs. A factor for individual DS3 channel interfaces and 28 DS1 channel systems, will be derived by dividing the number of activated BellSouth SWA access circuits associated with the DS3 channel by the voice grade (a.k.a. BellSouth SPA DSO VG) equivalent capacity of the DS3 channel. A DS3 has 672 voice grade (a.k.a. BellSouth SPA DSO VG) equivalent channels. For DS1 channel interfaces, a factor is derived by dividing the number of BellSouth SWA access circuits associated with the DS1 channel by the voice grade (a.k.a. BellSouth SPA DSO VG) equivalent capacity of the DS1 channel, which is 24. Each reduction factor is rounded to four decimal places and then multiplied against the respective monthly charges to determine the reduction amount.

BellSouth SWA rates and charges will apply for each channel of the shared use facility that is used to provide BellSouth SWA.

Where Special Access (a.k.a. BellSouth SPA) service is provided utilizing a channel(s) of the shared use facility to the Hub, High Capacity (a.k.a. BellSouth SPA High Capacity) rates and charges will apply for the portion of the facility ordered as Special Access (a.k.a. BellSouth SPA) to the Hub as set forth preceding and individual service rates and charges will apply from the Hub to the customer designated premises for the Special Access (a.k.a. BellSouth SPA) services ordered. The rates and charges that will apply to the portion from the Hub to the customer designated premises will be dependent on the specific type of Special Access (a.k.a. BellSouth SPA) service that is provided. The applicable rates and charges will include a local channel, interoffice channel, if applicable. Rates and charges for optional features and functions associated with the service, if any, will apply as set forth in Part 11, Section 7.5 of this guidebook.

(T)