

ACCESS SERVICE

RATES, RULES AND CHARGES

Title Page and Pages 1 to 22-45, inclusive of this tariff are effective as of the date shown. Original and revised pages as named below and Supplement No. 7 contains all changes from the original tariff that are in effect on the date hereof.

CHECK SHEET

<u>Page</u>	Number of Revision Except as Indicated	<u>Page</u>	Number of Revision Except as Indicated
Title	Original	22.3	Original
1	8th*	22.4	Original
1.1	1st*	23	Original
1.2	8th*	24	Original
1.2.1	Original	25	Original
1.3	1st	26	Original
1.4	5th*	27	Original
1.5	5th*	28	Original
1.5.1	Original	29	Original
1.6	3rd	30	Original
1.7	Original	31	Original
1.7.1	3rd	1-1	Original
1.8	Original	1-2	Original
1.9	Original	2-1	Original
1.10	Original	2-2	Original
1.11	Original	2-3	Original
1.12	Original	2-4	Original
1.13	Original	2-5	Original
1.14	Original	2-5.1	Original
1.15	Original	2-6	Original
1.15.1	Original	2-7	Original
1.16	Original	2-8	Original
2	Original	2-9	Original
3	Original	2-10	Original
4	Original	2-11	Original
5	Original	2-12	Original
6	Original	2-13	Original
7	Original	2-14	Original
8	Original	2-15	Original
9	Original	2-15.1	Original
10	3rd	2-16	Original
11	Original	2-17	Original
12	3rd	2-18	Original
13	Original	2-19	Original
14	3rd	2-20	Original
15	Original	2-21	Original
16	Original	2-22	Original
17	Original	2-23	Original
18	Original	2-24	Original
19	Original	2-25	Original
20	Original	2-26	Original
21	Original	2-27	Original
22	Original	2-28	Original
22.1	Original	2-29	Original
22.2	Original		

* New or Revised Page

Issuing Officer: Kristen E. Shore, Assistant Vice President - Regulatory
 (This page filed under Transmittal No. 8)

ACCESS SERVICE

RATES, RULES AND CHARGES

CHECK SHEET (Cont'd)

Page	Number of Revision Except as Indicated	Page	Number of Revision Except as Indicated
2-30	Original	2-69	Original
2-31	Original	2-70	Original
2-32	Original	2-71	Original
2-33	Original	2-72	Original
2-34	Original	2-73	Original
2-35	Original	2-74	Original
2-35.1	Original	2-75	Original
2-35.2	Original	2-76	Original
2-35.3	Original	2-77	Original
2-35.4	Original	2-78	Original
2-35.5	Original	2-79	Original
2-36	Original	2-80	Original
2-37	Original	2-81	Original
2-38	Original	2-82	Original
2-39	Original	2-83	Original
2-40	Original	2-84	Original
2-41	Original	2-85	Original
2-42	Original	2-86	Original
2-43	Original	2-86.1	Original
2-44	1st*	2-87	Original
2-45	1st*	2-88	Original
2-46	1st*	2-89	Original
2-47	Original	2-90	Original
2-48	Original	2-91	Original
2-49	Original	2-92	Original
2-50	Original	2-93	Original
2-51	Original	2-94	Original
2-52	Original	2-95	Original
2-53	Original	2-96	Original
2-54	Original	2-97	Original
2-55	Original	2-98	Original
2-56	Original	2-99	Original
2-57	Original	3-1	Original
2-58	Original	3-2	Original
2-59	Original	3-3	Original
2-60	Original	3-4	Original
2-61	Original	3-5	Original
2-62	Original	3-6	Original
2-63	Original	3-7	Original
2-64	1st*	3-8	Original
2-65	1st*	3-9	Original
2-66	1st*	3-10	Original
2-67	Original	3-11	Original
2-68	Original	3-12	Original

New or Revised Page

(This page filed under Transmittal No. 8)

Issued: November 20, 2024

Effective: December 5, 2024

Four AT&T Plaza, Dallas, Texas 75202

RATES, RULES AND CHARGES

CHECK SHEET (Cont'd)

Page	Number of Revision Except as Indicated	Page	Number of Revision Except as Indicated
3-13	Original	5-11.2	Original
3-14	Original	5-11.3	Original
3-15	Original	5-12	Original
3-16	Original	5-13	Original
3-17	Original	5-14	Original
3-18	Original	5-14.1	Original
3-19	Original	5-15	Original
3-20	Original	5-16	Original
3-21	Original	5-17	Original
3-22	Original	5-17.1	Original
3-23	Original	5-17.1.1	Original
3-24	Original	5-17.2	Original
3-25	Original	5-18	Original
3-26	Original	5-19	Original
3-27	Original	5-19.1	Original
3-28	Original	5-19.2	Original
3-29	Original	5-19.3	Original
3-30	Original	5-19.4	Original
4-1	Original	5-19.5	Original
4-2	Original	5-19.6	Original
4-3	Original	5-19.7	Original
4-4	Original	5-20	Original
4-5	Original	5-21	Original
4-6	Original	5-22	4th
4-7	Original	5-23	Original
4-8	Original	5-24	1st*
4-8.1	Original	5-25	Original
4-9	2nd	5-26	Original
4-10	2nd	5-27	Original
4-10.1	1st	5-28	Original
4-11	3rd	6-1	Original
5-1	3rd	6-2	3rd
5-2	Original	6-3	Original
5-3	Original	6-4	Original
5-3.1	Original	6-5	Original
5-3.2	Original	6-6	Original
5-3.3	Original	6-7	Original
5-3.4	Original	6-8	3rd
5-4	Original	6-9	Original
5-5	Original	6-10	Original
5-6	Original	6-11	Original
5-7	Original	6-12	Original
5-8	Original	6-13	Original
5-9	1st*	6-14	Original
5-10	Original	6-15	Original
5-11	Original	6-16	Original
5-11.1	Original		

New or Revised Page

(This page filed under Transmittal No. 8)

Issued: November 20, 2024

Effective: December 5, 2024

Four AT&T Plaza, Dallas, Texas 75202

ACCESS SERVICE
RATES, RULES AND CHARGES
CHECK SHEET (Cont'd)

Page	Number of Revision Except as Indicated	Page	Number of Revision Except as Indicated
6-104	Original	6-147	Original
6-105	Original	6-148	Original
6-106	Original	6-149	Original
6-107	Original	6-150	Original
6-108	Original	6-151	Original
6-109	Original	6-152	Original
6-110	Original	6-153	Original
6-111	Original	6-154	Original
6-112	Original	6-155	Original
6-113	Original	6-156	Original
6-113.1	Original	6-157	Original
6-114	Original	6-158	Original
6-115	Original	6-159	Original
6-116	Original	6-160	Original
6-117	Original	6-161	Original
6-118	Original	6-162	Original
6-119	Original	6-163	Original
6-120	Original	7-1	4th*
6-121	Original	7-2	Original
6-122	Original	7-2.1	Original
6-123	Original	7-3	1st*
6-124	Original	7-4	Original
6-125	Original	7-5	Original
6-126	Original	7-6	Original
6-127	Original	7-7	Original
6-128	Original	7-8	Original
6-129	Original	7-9	Original
6-130	Original	7-10	1st*
6-131	Original	7-11	Original
6-132	Original	7-12	1st*
6-133	Original	7-13	1st*
6-134	Original	7-14	4th*
6-135	Original	7-15	Original
6-136	Original	7-16	Original
6-137	Original	7-17	1st*
6-138	Original	7-18	1st*
6-139	Original	7-19	Original
6-140	Original	7-20	Original
6-141	Original	7-21	Original
6-142	Original	7-22	Original
6-143	Original	7-23	1st*
6-144	Original	7-24	Original
6-145	4th	7-25	Original
6-146	Original		

New or Revised Page

(This page filed under Transmittal No. 8)

Issued: November 20, 2024

Effective: December 5, 2024

Four AT&T Plaza, Dallas, Texas 75202

ACCESS SERVICE

RATES, RULES AND CHARGES
 CHECK SHEET (Cont'd)

<u>Page</u>	<u>Number of Revision Except as Indicated</u>	<u>Page</u>	<u>Number of Revision Except as Indicated</u>
7-26	Original	7-81	4th*
7-27	1st*	7-81.1	1st*
7-28	1st*	7-81.2	Original
7-29	Original	7-81.3	1st*
7-30	1st*	7-81.4	Original
7-31	5th*	7-81.5	Original
7-32	4th	7-81.6	Original
7-33	1st*	7-81.6.1	Original
7-33.1	Original	7-81.7	Original
7-34	Original	7-81.8	Original
7-35	Original	7-82	1st*
7-36	Original	7-83	1st*
7-37	Original	7-84	1st*
7-38	Original	7-84.1	1st*
7-39	Original	7-85	Original
7-40	Original	7-85.1	Original
7-41	Original	7-85.2	1st*
7-42	Original	7-86	Original
7-43	Original	7-87	Original
7-44	Original	7-87.1	Original
7-45	Original	7-87.2	Original
7-46	Original	7-87.3	Original
7-47	Original	7-87.4	Original
7-48	Original	7-88	Original
7-49	Original	7-89	Original
7-50	Original	7-90	Original
7-51	Original	7-91	Original
7-52	Original	7-91.1	Original
7-53	Original	7-91.2	Original
7-54	1st*	7-91.2.1	Original
7-55	Original	7-91.3	Original
7-56	1st*	7-91.4	Original
7-57	Original	7-91.5	Original
7-58	Original	7-91.6	Original
7-59	Original	7-91.7	Original
7-60	Original	7-91.8	Original
7-61	Original	7-91.9	Original
7-62	Original	7-91.10	Original
7-63	Original	7-92	Original
7-64	1st*	7-93	Original
7-65	Original	7-93.1	Original
7-66	Original	7-94	Original
7-66.1	Original	8-1	Original
7-67	Original	8-2	Original
7-68	Original	8-3	Original
7-69	1st*	8-3.1	Original
7-69.1	Original	8-4	Original
7-69.2	Original	8-5	Original
7-70	Original	8-6	Original
7-71	Original	8-7	Original
7-72	Original	8-8	Original
7-73	1st*	8-9	Original
7-74	Original	8-10	Original
7-75	Original	8-11	Original
7-76	Original	8-12	Original
7-77	1st*	8-13	Original
7-78	1st*	8-14	Original
7-78.1	1st*	8-15	Original
7-79	1st*	8-16	Original
7-79.1	1st*	8-17	Original
7-80	1st*	8-18	Original
		8-19	Original

New or Revised

(This page filed under Transmittal No. 8)

2. General Regulations2.4 Payment Arrangements and Credit Allowances (Cont'd)2.4.4 Credit Allowance for Service Interruptions(A) General

A service is interrupted when it becomes unusable to the customer because of a failure of a facility component used to furnish service under this tariff, or in the event that the protective controls applied by the Telephone Company result in the complete loss of service by the customer as set forth in 6.5.1 following. An interruption period starts when an inoperative service is reported to the Telephone Company, and ends when the service is operative.

(B) When a Credit Allowance Applies

In case of an interruption to any service, allowance for the period of interruption, if not due to the negligence of the customer, shall be as follows:

- (1) For Special Access Services other than Program Audio⁽¹⁾ and Video Services and for CCS/SS7 interconnection and Switched Transport Service, no credit shall be allowed for an interruption of less than 30 minutes. The customer shall be credited for an interruption of 30 minutes or more at the rate of 1/1440 of the monthly charges for the service for each period of 30 minutes or major fraction thereof that the interruption continues. The monthly charges used to determine the credit shall be as follows.
- (a) For two-point Special Access service, the monthly charge shall be the total of all the monthly rate element charges associated with the service (i.e., two (C) channel terminations, channel mileage⁽²⁾ and optional features and functions⁽²⁾). (N)
(N)

⁽¹⁾ Program Audio is discontinued and no longer available in this publication (see WC Dkt. 19-238).

⁽²⁾ These services have been de-tariffed pursuant to FCC Order No. 17-43, released April 28, 2017. Terms and Conditions for de-tariffed services are available at www.att.com/guidebook. (N)
(N)
(N)

(This page filed under Transmittal No. 8)

2. General Regulations

2.4 Payment Arrangements and Credit Allowances (Cont'd)

2.4.4 Credit Allowance for Service Interruptions (Cont'd)

(B) When a Credit Allowance Applies (Cont'd)

(1) (Cont'd)

(b) For multipoint Special Access Services, the monthly charge shall be only the total of all the monthly rate element charges associated with that portion of the service that is inoperative (i.e., a channel termination per customer premises.) (D)

(c) For multiplexed services (including Switched Transport Services), the monthly charge shall be the total of all the monthly rate element charges associated with that portion of the service that is inoperative. When the facility which is multiplexed or the multiplexer itself is inoperative, the monthly charge shall be the total of all the monthly rate element charges associated with the service (i.e., the channel termination, or Direct Trunked Transport and optional features and functions, including the multiplexer on the facility to the Hub and the channel terminations, or Direct Trunk Transport and optional features and functions on the individual from the Hub). When the service which rides a channel of the multiplexed facility is inoperative, the monthly charge shall be the total of all the monthly rate element charges associated with that portion of the service from the Hub to a customer premises or end office (i.e., channel termination, Direct Trunk Transport and optional features and functions). (D)

(d) For Switched Transport Services, the monthly charge shall be the total of all the monthly rate element charges associated with the Service (i.e., Entrance Facility and Direct Trunked Transport). (D)

(This page filed under Transmittal No. 8)

2. General Regulations

2.4 Payment Arrangements and Credit Allowances (Cont'd)

2.4.4 Credit Allowance for Service Interruptions (Cont'd)

(B) When a Credit Allowance Applies (Cont'd)

(2) For Program Audio⁽¹⁾ and Video Special Access Service, no credit shall be allowed for an interruption of less than 30 seconds. The customer shall be credited for an interruption of 30 seconds or more as follows:

(a) For two-point services, when monthly rates are applicable, the credit shall be at the rate of 1/8640 of the monthly charges for the service for each period of 5 minutes or major fraction thereof that the interruption continues.

(b) For two-point services, when daily rates are applicable, the credit shall be at the rate of 1/288 of the daily charges for the service for each period of 5 minutes or major fraction thereof that the interruption continues.

(c) For multipoint services, when monthly rates are applicable, the credit shall be at the rate of 1/8640 of the monthly charges for all channel terminations, features and functions that are inoperative for each period of 5 minutes or major fraction thereof that the interruption continues. (D)
(C)

(d) For multipoint services, when daily rates are applicable, the credit shall be at the daily rate of 1/288 of the daily charges for all channel terminations, and functions that are inoperative for each period of 5 minutes or major fraction thereof that the interruption continues. (D)
(C)

⁽¹⁾ Program Audio is discontinued and no longer available in this publication (see WC Dkt. 19-238).

(This page filed under Transmittal No. 8)

2. General Regulations

2.4 Payment Arrangements and Credit Allowances (Cont'd)

2.4.8 Access Services Provided By More Than One Telephone Company
(Cont'd)

(A) (Cont'd)

(2) Meet Point Billing (Cont'd)

(b) Multiple Bill Option (Cont'd)

- bill in accordance with its access tariff; and
- forward the bill to the customer.

The customer will remit the payment directly to each Telephone Company that bills it.

(c) Determination of Meet Point Billed Local Transport, Directory Transport and Channel Mileage Charges⁽¹⁾

(N)

- (i) Determine the appropriate Local Transport or Channel Mileage by computing the number of airline miles between the Telephone Company premises (end office, access tandem or serving wire centers for Switched Access or serving wire centers for Special Access) using the V&H method set forth in 6.7.11, and 7.2.5 following.

⁽¹⁾These service(s) have been de-tariffed pursuant to FCC Order No. 17-43, released April 28, 2017. Terms and Conditions for de-tariffed services are available at www.att.com/guidebook.

(N)
I
(N)

(This page filed under Transmittal No. 8)

2. General Regulations

2.4 Payment Arrangements and Credit Allowances (Cont'd)

(A) (Cont'd)

(2) Meet Point Billing (Cont'd)

(c) Determination of Meet Point Billed Local Transport, Directory Transport and Channel Mileage Charges⁽¹⁾ (Cont'd)

(N)

(ii) Determine the billing percentage (BP), as set forth in NATIONAL EXCHANGE CARRIER ASSOCIATION, INC. TARIFF F.C.C. No. 4, which represents the portion of the service provided by each Telephone Company.

(iii) For ATA950, ATAXXX or for Feature Group B and D Switched Access Services using BP Method, (1) multiply the number of access minutes of use times the number of airline miles, as set forth in (i) preceding, times the BP for each Telephone Company, as set forth in (ii) preceding times the Local Transport Facility rate; (2) multiply the Local Transport Termination rate times the number of access minutes.

The Local Transport Termination rate is applied as set forth in 6.1.2(A), following.

⁽¹⁾These services have been de-tariffed pursuant to FCC Order No. 17-43, released April 28, 2017. Terms and Conditions for de-tariffed services are available at www.att.com/guidebook.

(N)
|
(N)

(This page filed under Transmittal No. 8)

2. General Regulations

2.4 Payment Arrangements and Credit Allowances (Cont'd)

2.4.8 Access Services Provided By More Than One Telephone Company
(Cont'd)

(A) (Cont'd)

(2) Meet Point Billing (Cont'd)

(c) Determination of Meet Point Billed Local Transport, Directory Transport and Channel Mileage Charges⁽¹⁾ (Cont'd)

(N)

(iv) For Special Access using BP method, multiply the number of airline miles, as set forth in (i) preceding, times the BP for each Telephone Company, as set forth in (ii) preceding, times the Channel Mileage Facility rate. Add the Channel Mileage Termination rate.

(v) For Directory Assistance Service, multiply the Directory Transport rate times the number of directory assistance calls times the BP for each Telephone Company, as set forth in (ii) preceding.

(vi) When three or more Telephone Companies are involved in providing an Access Service, the intermediate Telephone Company(s) will determine the appropriate charges as set forth in (iii) and (iv) preceding, except the Local Transport Termination or Channel Mileage Termination rate does not apply.

⁽¹⁾These services have been de-tariffed pursuant to FCC Order No. 17-43, released April 28, 2017. Terms and Conditions for de-tariffed services are available at www.att.com/guidebook.

(N)
|
(N)

(This page filed under Transmittal No. 8)

5. Ordering Options for Switched and Special Access Service5.2 Access Order (Cont'd)

For Toll Free or 900 Access Service, the customer shall order in the same manner which is set forth preceding for ordering ATAXXX or Feature Group D. Additionally, for 900 Access Service, when new NXX(S) are to be opened in the entire LATA or market area or when existing NXX (s) are to be deleted, and such change is to occur coincident with the service date established for the order, the customer shall provide such information when placing the order for service. Customer assigned NXX codes which have not been ordered will be blocked. If the change is to occur absent the requirement for additional capacity (i.e., busy hour minutes of capacity or quantities of trunks), the customer shall notify the Telephone Company of the change as set forth in 6.6.1, following.

All 900 number assignments and administration shall be in accordance with the North American Numbering Plan (NANP). All Toll Free number assignments and administration will be performed by the Toll Free Access Service Management System (SMS).

Special Access Service may be ordered for connection with an ALA, ATA, FGA, FGB, or FGD Switched Access Service at Telephone Company designated WATS Serving offices (WSOs) for the provision of WATS or WATS-type Services and may be ordered separately by a customer other than the customer which orders the ALA, ATA, FGA, FGB, or FGD Switched Access Service. For the Special Access Service the customer shall specify the customer designated premises at which the Special Access Service terminates, the type of line (i.e., two-wire or four-wire), the type of calling (i.e., originating, terminating, or two way) and the type of Supervisory Signaling. When the optional screening, switching and/or recording functions are not provided at the customer serving wire center, Channel Mileage⁽¹⁾, must be ordered between that wire center and the nearest WSO where the screening, switching and/or recording functions can be provided.

(N) (D)

⁽¹⁾ This service has been de-tariffed pursuant to FCC Order No. 17-43, released April 28, 2017. Terms and Conditions for de-tariffed services are available at www.att.com/guidebook.

(N)
|
(N)

(This page filed under Transmittal No. 8)

5. Ordering Options for Switched and Special Access Service (Cont'd)5.2 Access Order (Cont'd)5.2.9 Access Orders For Services Provided By More Than One Exchange Telephone Company

- (A) Access Services provided by more than one Telephone Company are services where one end of the Switched Transport or Directory Transport element is in the operating territory of one Telephone Company and the other end of the element is in the operating territory of a different Telephone Company. (C) (D)

The ordering procedure for this service is dependent upon the billing arrangement, as set forth in 2.4.8 preceding, to be used by the Telephone Companies involved in providing the Access Service. The ordering and design arrangements will be consistent with the provisions contained in this section and the ordering and Billing Forum standards, Multiple Exchange Carrier Access Billing (MECAB) and Multiple Exchange Carrier Ordering and Design (MECOD). The Telephone Company will notify the customer which of the ordering procedures will apply.

(1) Non Meet Point Billing(a) Single Company Billing ordering

The company where the first point of switching is located shall accept the order for ALA, ATA950, FGA and FGB service. The other company involved shall also receive a copy of the order from the customer.

The Telephone Company receiving the order from the customer will arrange to provide the service and bill the customer as set forth in 2.4.8(A) (1) (a). The customer will place the order with the Telephone Company as follows:

(This page filed under Transmittal No. 8)

	<u>Page No.</u>	
7. <u>SPECIAL ACCESS SERVICE</u>	7-1	
7.1 <u>General</u>	7-3	
7.1.1 Channel Types	7-3	
7.1.2 Service Descriptions	7-6	
7.1.3 Service Configurations	7-9	
7.1.4 Alternate Use	7-13	
7.1.5 Special Facilities Routing	7-14	
7.1.6 Design Layout Report	7-14	
7.1.7 Acceptance Testing	7-14	
7.1.8 Ordering Options and Conditions	7-15	
7.2 <u>Rate Regulations</u>	7-16	
7.2.1 Rate Categories	7-16	
7.2.2 Types of Rates and Charges	7-21	
7.2.3 Moves	7-27	
7.2.4 Minimum Periods	7-27	
7.2.5 ⁽¹⁾	7-28	(N) (D)
7.2.6 Facility Hubs	7-29	
7.2.7 Shared Use Analog and Digital High Capacity Services	7-31	
7.2.8 Extension of WATS Access Service	7-33	
7.3 <u>Surcharge for Special Access Service</u>	7-34	
7.3.1 General	7-34	
7.3.2 Application	7-34	
7.3.3 Exemption of Special Access Service	7-35	
7.3.4 Rate Regulations	7-36	
7.3.5 Rate	7-38	
7.4 <u>Message Station Equipment Recovery Charge</u>	7-39	
7.4.1 General	7-39	
7.4.2 Rate	7-39	
7.5 <u>Reserved for Future Use</u>	7-40	
7.6 <u>Reserved for Future Use</u>	7-41	

(x) Issued under authority of Special Permission No. 24-006 of the FCC in order to withdraw material filed under Transmittal No. 2 and Transmittal No. 4.

(1) This service has been de-tariffed pursuant to FCC Order No. 17-43, released April 28, 2017. Terms and Conditions for de-tariffed services are available at www.att.com/guidebook.

(N)
|
(N)

(This page filed under Transmittal No. 8)

7. Special Access Service

Non-Competitive End-User Channel Terminations (and associated optional features and functions) are the Special Access Services offered under this tariff. Other Special Access Services required to complete a circuit are available at www.att.com/guidebook.

(N)
|
(N)

7.1 General

Special Access Service provides a transmission path to connect customer designated premises*, directly, through a Telephone Company hub or hubs where bridging or multiplexing functions are performed, or to connect a customer designated premises and a WATS Serving Office. Special Access Service includes all exchange access not utilizing Telephone Company end office switches.

The connections provided by Special Access Service can be either analog or digital. Analog connections are differentiated by spectrum and bandwidth. Digital connections are differentiated by bit rate.

Special Access Services are ordered under the Access Order provisions set forth in Section 5. preceding.

Rates and charges for Special Access Service are set forth in Sections 7.7.6, 7.8.5, 7.9.4, 7.10.5, and 7.11.5 following.

(D)
|
(D)

7.1.1 Channel Types

There are seven types of channels used to provide Special Access Services. Each type has its own characteristics. All are subdivided by one or more of the following:

- Transmission specifications,
- Bandwidth,
- Speed (i.e., bit rate),
- Spectrum

Non-Competitive End User customers can order a basic channel and select from a list of available transmission parameters and channel interfaces those that they desire to meet specific communications requirements.

(C)

For purposes of ordering channels, each has been identified as a type of Special Access Service. However, such identification is not intended to limit a customer's use of the channel nor to imply that the channel is limited to a particular use. For example, if a customer's equipment is capable of transmitting voice over a channel that is identified as a Metallic Service in this tariff, there is no restriction against doing so.

* Telephone Company Centrex CO and CO-like switches and Interconnection Chambers for EIS are considered to be a customer designated premises for purposes of this tariff.

7. Special Access Service (Cont'd)

7.1.3 Service Configurations (Cont'd)

(A) Two-Point Service (Cont,d)

Applicable rate elements are:

- Channel Terminations
- Channel Mileage⁽¹⁾ (as applicable) (N)
- optional Features and Functions (when applicable)

A Special Access Surcharge, as set forth in 7.3 following and a Message Station Equipment Recovery Charge, as set forth in 7.4 following, may be applicable.

The following diagram depicts a two-point Voice Grade service connecting two customer designated premises (CDP). The service is provided with C-Type conditioning.

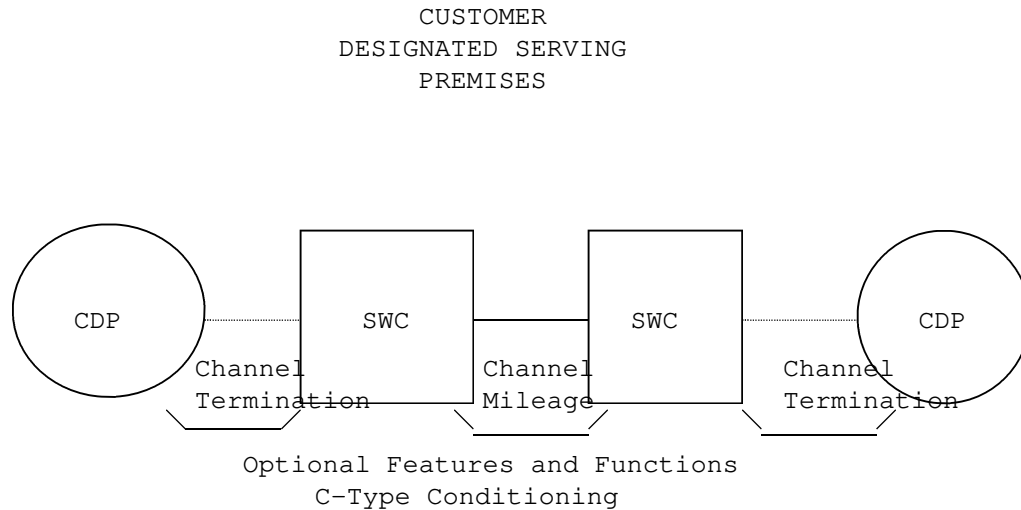

Applicable rate elements are:

- Channel Terminations (applicable one (1) per CDP*)
- Channel Mileage⁽¹⁾ (i section, Channel Mileage⁽¹⁾ Facility (N)
per mile plus 2 Channel Mileage⁽¹⁾ Terminations) (N)
- C-Type conditioning Optional Feature

* When CDP is an Interconnection Chamber (See EIS Service Section 18 following) the EIS Channel Termination as described in Section 18 following will apply.

⁽¹⁾ This service has been de-tariffed pursuant to FCC Order No. 17-43, released April 28, 2017. Terms and Conditions for de-tariffed services are available at www.att.com/guidebook. (N)

(This page filed under Transmittal No. 8)

7. Special Access Service (Cont'd)

7.1 General (Cont'd)

7.1.3 Service Configurations (Cont'd)

(B) Multipoint Service⁽¹⁾ (Cont'd)

-

(N)

(D)

(D)

⁽¹⁾ Material in this Section has been de-tariffed pursuant to FCC Order No. 17-43, released April 28, 2017. Terms and Conditions for de-tariffed services are available at www.att.com/guidebook.

(N)

|

(N)

(This page filed under Transmittal No. 8)

7. Special Access Service (Cont'd)

7.1 General (Cont'd)

7.1.3 Service Configurations (Cont'd)

(B) Multipoint Service⁽¹⁾ (Cont'd)

(N)

(D)



(D)

7.1.4 Alternate Use

Alternate Use occurs when a service is arranged by the Telephone Company so that the customer can select different types of transmission at different times. A customer may use a service in any privately beneficial manner. However, where technical or engineering changes are required to effectuate an alternate use, the Telephone Company will make such special arrangements available on an individual case basis.

The arrangement required to transfer the service from one operation to the other (i.e., the transfer relay and control leads) will be rated and provided on an individual case basis and filed in Section 12., Specialized Service or Arrangements. The customer will pay the stated tariff rates for the Access Service rate elements for the service ordered (i.e., Channel Terminations).

(C) (D)

(D)

⁽¹⁾ This material has been de-tariffed pursuant to FCC Order No. 17-43, released April 28, 2017. Terms and Conditions for de-tariffed services are available at www.att.com/guidebook.

(N)



(N)

(This page filed under Transmittal No. 8)

ACCESS SERVICE
 TABLE OF CONTENTS

	<u>Page No.</u>	
7. <u>SPECIAL ACCESS SERVICE</u>	7-2	
7.1 <u>General</u>	7-3	
7.1.1 Channel Types	7-3	
7.1.2 Service Descriptions	7-6	
7.1.3 Service Configurations	7-9	
7.1.4 Alternate Use	7-13	
7.1.5 Special Facilities Routing	7-14	
7.1.6 Design Layout Report	7-14	
7.1.7 Acceptance Testing	7-14	
7.1.8 Ordering Options and Conditions	7-15	
7.2 <u>Rate Regulations</u>	7-16	
7.2.1 Rate Categories	7-16	
7.2.2 Types of Rates and Charges	7-21	
7.2.3 Moves	7-27	
7.2.4 Minimum Periods	7-27	
7.2.5 ⁽²⁾	7-27	(N) (D)
7.2.6 Facility Hubs	7-29	
7.2.7 Shared Use Analog and Digital High Capacity Services	7-31	
7.2.8 Extension of WATS Access Service	7-33	
7.2.9 ⁽¹⁾		
7.3 <u>Surcharge for Special Access Service</u>	7-34	
7.3.1 General	7-34	
7.3.2 Application	7-34	
7.3.3 Exemption of Special Access Service	7-35	
7.3.4 Rate Regulations	7-36	
7.3.5 Rate	7-38	
7.4 <u>Message Station Equipment Recovery Charge</u>	7-39	
7.4.1 General	7-39	
7.4.2 Rate	7-39	

⁽¹⁾ Material in this Section has been de-tariffed as required by the Commission upon use of the forbearance relief pursuant to FCC Memorandum Opinion and Order No. 07-180, released October 12, 2007. Terms and Conditions associated with de-tariffed services are available at www.att.com/guidebook.

⁽²⁾ This service has been de-tariffed pursuant to FCC Order No. 17-43, released April 28, 2017. Terms and Conditions for de-tariffed services are available at www.att.com/guidebook. (N)
 (N)
 (N)

(x) Issued under authority of Special Permission No. 24-006 of the FCC in order to withdraw material filed under Transmittal No. 2 and Transmittal No. 4.

(This page filed under Transmittal No. 8)

7. Special Access Service (Cont'd)

7.2 Rate Regulations (Cont'd)

7.2.1 Rate Categories (Cont'd)

(A) Channel Termination

The Channel Termination rate category provides for the communications path between an end user customer designated premises and the serving wire center of that premises. It also provides for the unrecovered portion of inside wire investment assigned to Special Access Service. Included as part of the Channel Termination is a standard channel interface arrangement which defines the technical characteristics associated with the type of facilities to which the access service is to be connected at the Point of Termination (POT) and the type of signaling capability, if any. The signaling capability is provided as an optional feature as set forth in (C) following. One Channel Termination charge applies per customer designated premises at which the channel is terminated. For WATS Access Line Service, only one Channel Termination applies per service. This charge will apply even if the customer designated premises and the serving wire center are collocated in a Telephone Company building. (C)

(B⁽¹⁾)

(N)
(D)
|
(D)

(1) Material in this Section has been de-tariffed pursuant to FCC Order No. 17-43, released April 28, 2017. Terms and Conditions for de-tariffed services are available at www.att.com/guidebook. (N)
|
(N)

(This page filed under Transmittal No. 8)

7. Special Access Service (Cont'd)

7.2 Rate Regulations (Cont'd)

7.2.1 Rate Categories (Cont'd)

(B) ⁽¹⁾

(N) (D)

(D)

⁽¹⁾ Material in this Section has been de-tariffed pursuant to FCC Order No. 17-43, released April 28, 2017. Terms and Conditions for de-tariffed services are available at www.att.com/guidebook. (N)
|
(N)

(This page filed under Transmittal No. 8)

7. Special Access Service (Cont'd)7.2 Rate Regulations (Cont'd)7.2.2 Types of Rates and Charges (Cont'd)(C) Nonrecurring Charges (Cont'd)(3) Service Rearrangements

Service rearrangements are changes to existing (installed) services which may be administrative only in nature, as set forth following, or that involve actual physical change to the service. Changes to pending orders are set forth in 5.2.2 preceding.

Changes in the physical location of the point of termination or customer designated premises are moves as set forth in 7.2.3 following.

Changes in the type of Service or Channel Termination which result in a change of the minimum period requirement will be treated as a discontinuance of the service and an installation of a new service.

Customers with DS3 service provided under Individual Case Basis (ICB) in other portions of this tariff or with a month-to-month billing period who wish to convert their DS3 service to a 1 or 3 year billing period, may do so without penalty or assessment of new nonrecurring charges, providing there is no physical change in the service arrangement. (C)

Changes in ownership or transfer of responsibility from one customer to another will be treated as a discontinuance of the service and an installation of a new service. In the event the change in ownership or transfer of responsibility as set forth in 2.1.2(A) preceding where there is no change in facilities or arrangements, the change will be treated as an administrative change without charge to the customer.

(This page filed under Transmittal No. 8)

7. Special Access Service (Cont'd)
 7.2 Rate Regulations (Cont'd)
 7.2.3 Moves

A move involves a change in the physical location of one of the following:

- The Point of Termination at the customer's premises
- The customer's premises

The charges for the move are dependent on whether the move is to a new location within the same building or to a different building.

(A) Moves Within the Same Building

When the move is to a new location within the same building or a change of connecting facility assignment in the same central office other than DS1 and DS3 rollover rearrangements as described in 7.2.2(C) (3) (c) preceding, the charge for the move will be an amount equal to one half of the nonrecurring (i.e., installation) charge for the service termination affected. There will be no change in the minimum period requirements.

(B) Moves To a Different Building

Moves to a different building will be treated as a discontinuance and start of service and all associated nonrecurring charges will apply. New minimum period requirements will be established for the new services. The customer will also remain responsible for satisfying all outstanding minimum period charges for the discontinued service.

7.2.4 Minimum Periods

The minimum service period for all services is one month, except DS3 High Capacity Service under a 1 or 3-year⁽⁴⁾ billing period, and part-time Video and Program Audio services^{(1) (3)}. (D)

(A) The minimum service period for part-time Video⁽²⁾ and Program Audio^{(1) (3)} services is one day (i.e., a continuous 24-hour period, not limited to a calendar day).

(B) The minimum service period for DS3 (44.746 Mbps) High Capacity Special Access Service is a 1-year⁽⁴⁾ term plan. After the 1 or 3-year billing period is satisfied, the customer must select a renewal option as referenced in Section 7.11.5.1. (D)

- (1) Effective November 20, 2019, this Service will no longer be available for purchase by new or existing customers, and service agreements may no longer be renewed. In addition, requests to move, add or change existing service arrangements will not be accepted. Following the expiration of a customer's existing term agreement, service will be provided on a month-to-month basis at the applicable monthly extension rates until the service is discontinued. AT&T currently plans to discontinue this Service on or after November 1, 2020.
- (2) Effective December 31, 2020, Broadcast Video (TV1) service will no longer be available for purchase by new or existing customers, and service agreements may no longer be renewed. In addition, requests to move, add, or change existing service arrangements will not be accepted. Following the expiration of a customer's existing term agreement, service will be provided on a month-to-month basis at the applicable Monthly rate until the service is discontinued. AT&T currently plans to discontinue this Service on or after December 31, 2021.
- (3) Program Audio is discontinued and no longer available in this publication (see WC Dkt. 19-238).
- (4) Effective January 17, 2024, the 1-year minimum period for DS3 (44.746 Mbps) High Capacity Special Access Service no longer applies.

(This page filed under Transmittal No. 8)

7. Special Access Service (Cont'd)

7.2 Rate Regulations (Cont'd)

7.2.5⁽¹⁾

(N) (D)

(D)

⁽¹⁾ Material in this Section has been de-tariffed pursuant to FCC Order No. 17-43, released April 28, 2017. Terms and Conditions for de-tariffed services are available at www.att.com/guidebook. (N)
|
(N)

(This page filed under Transmittal No. 8)

7. Special Access Service (Cont'd)

7.2 Rate Regulations (Cont'd)

7.2.6 Facility Hubs (Cont'd)

The Telephone Company will commence billing the monthly rate for the service to the hub on the date specified by the customer on the Access Order. Individual channels utilizing these services may be installed coincident with the installation of the service to the hub or may be ordered and/or installed at a later date, at the option of the customer. The customer will be billed for a Voice Grade or a High Capacity Channel Termination, Channel Mileage⁽¹⁾ (when applicable), and the multiplexer⁽¹⁾ at the time the service is installed. Individual service rates (by service type) will apply for a Channel Termination and additional Channel Mileage⁽¹⁾ (as required) for each channelized service. These will be billed to the customer as each individual service is installed. (N)

Cascading multiplexing⁽¹⁾ occurs when a High Capacity service is de-multiplexed to provide channels with a lesser capacity and one of the lesser capacity channels is further de-multiplexed⁽¹⁾. For example, a 6.312 Mbps High Capacity service is de-multiplexed⁽¹⁾ to four DS1 channels and then one of the DS1 channels is further de-multiplexed⁽¹⁾ to 24 individual Voice Grade channels. (N)

When cascading multiplexing⁽¹⁾ is performed, whether in the same or a different hub, a charge for the additional multiplexing⁽¹⁾ unit also applies. When cascading multiplexing⁽¹⁾ is performed at different hubbing locations, Channel Mileage⁽¹⁾ charges also apply between the hubs. (N)

(1) This service has been de-tariffed pursuant to FCC Order No. 17-43, released April 28, 2017. Terms and Conditions for de-tariffed services are available at www.att.com/guidebook. (N)

(This page filed under Transmittal No. 8)

7. Special Access Service (Cont'd)7.2 Rate Regulations (Cont'd)7.2.6 Facility Hubs (Cont'd)

The Telephone Company will designate hubs for Video⁽¹⁾ and Program Audio⁽²⁾ Services. Full-time or part-time service may be provided between customer designated premises or between a customer designated premises and a hub and billed accordingly at the monthly rates set forth in 7.8 and 7.9 following for a Channel Termination, Channel Mileage⁽³⁾ and Optional Features and Functions, as applicable. When the service is ordered to a hub, the customer may order a full-time or part-time Video and Program Audio⁽²⁾ services as needed between that hub and additional customer designated premises. The rate elements required to provide the part-time service (i.e., Channel Termination, Channel Mileage⁽³⁾ and Optional Features and Functions, as applicable) will be billed at daily rates for the duration of the service requested. (N)

7.2.7 Shared Use Analog and Digital High Capacity Services

Shared Use occurs when Special Access Service and Switched Access Service are provided over the same High Capacity Special Access facility through a common interface. The Special Access monthly rate for the Channel Termination, Channel Mileage⁽³⁾, if applicable, and multiplexer⁽³⁾ will apply, regardless of whether any individual channels of the Shared Special Access facility are used for Special Access Service, Switched Access Service, or any other type of service. The practice known as "ratcheting" (to apply non-Special Access rates on a proportional basis) shall not apply in any circumstance. (N)

(1) Effective December 31, 2020, Broadcast Video (TV1) service will no longer be available for purchase by new or existing customers, and service agreements may no longer be renewed. In addition, requests to move, add, or change existing service arrangements will not be accepted. Following the expiration of a customer's existing term agreement, service will be provided on a month-to-month basis at the applicable Monthly rate until the service is discontinued. AT&T currently plans to discontinue this Service on or after December 31, 2021.

(2) Program Audio is discontinued and no longer available in this publication (see WC Dkt. 19-238).

(3) This service has been de-tariffed pursuant to FCC Order No. 17-43, released April 28, 2017. Terms and Conditions for de-tariffed services are available at www.att.com/guidebook. (N)

(x) Issued under authority of Special Permission No. 24-006 of the FCC in order to withdraw material filed under Transmittal No. 2 and Transmittal No. 4. (N)

(This page filed under Transmittal No. 8)

ACCESS SERVICE

7. Special Access Service (Cont'd)7.2 Rate Regulations (Cont'd)7.2.8 Extension of WATS Access Service

WATS Access Service is available with extensions, i.e., additional terminations, of the service at different customer designated premises in the same or different LATAs. Extensions are provided and charged for as separate Voice Grade⁽²⁾ Special Access Service. The rate elements which apply are: WATS Access Line Channel Termination, Channel Mileage⁽³⁾, if applicable, and Signaling Capability (Optional Features and Functions), if applicable. All appropriate charges as set forth in 7.7.6 following will apply. (N)

7.2.9⁽¹⁾

⁽¹⁾ Material in this Section has been de-tariffed as required by the Commission upon use of the forbearance relief pursuant to FCC Memorandum Opinion and Order No. 07-180, released October 12, 2007. Terms and Conditions associated with de-tariffed services are available at www.att.com/guidebook.

⁽²⁾ Effective November 20, 2019, this Service will no longer be available for purchase by new or existing customers, and service agreements may no longer be renewed. In addition, requests to move, add or change existing service arrangements will not be accepted. Following the expiration of a customer's existing term agreement, service will be provided on a month-to-month basis at the applicable monthly extension rates until the service is discontinued. AT&T currently plans to discontinue this Service on or after June 30, 2024.

⁽³⁾ This service has been de-tariffed pursuant to FCC Order No. 17-43, released April 28, 2017. Terms and Conditions for de-tariffed services are available at www.att.com/guidebook. (N)

(This page filed under Transmittal No. 8)

7. Special Access Service (Cont'd)

7.7 Voice Grade Service (Cont'd)

7.7.5 WATS Access Line (WAL) Service (Cont'd)

(A) Basic Channel Description (Cont'd)

The following diagram depicts a WATS Access Line service.

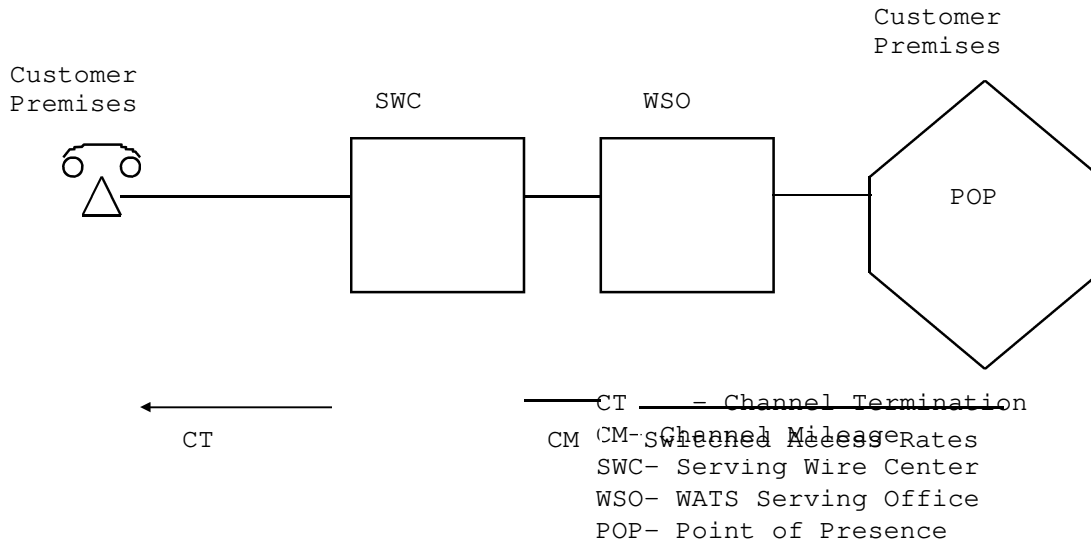

Applicable Rate elements are:

- CT - Channel Termination (1 applicable)
- CM - Channel Mileage⁽¹⁾
 - Optional Features and Functions when ordered (per channel termination).

(N)

(B) Technical Specifications

Technical specifications and examples of application are delineated in Technical Reference TR-NPL-000334.

(C) Channel Interfaces

Compatible channel interfaces are set forth in Technical Reference TR-NPL-000334.

⁽¹⁾ This service has been de-tariffed pursuant to FCC Order No. 17-43, released April 28, 2017. Terms and Conditions for de-tariffed services are available at www.att.com/guidebook.

(N)
 |
 (N)

(This page filed under Transmittal No. 8)

7. Special Access Service (Cont'd)

7.7 Voice Grade Service⁽³⁾ (Cont'd)

7.7.6 Rates and Charges

Only Non-Competitive End User channel terminations and their applicable optional features⁽²⁾ are available in this tariff.

(C)
 |
 (C)
 (D)
 |
 (D)
 (N)

		<u>Non-Competitive Rates</u>	
		Non-	
		<u>Monthly</u>	<u>Recurring</u>
		<u>Rate</u>	<u>Charge</u>
(A)	<u>Channel Termination</u>	<u>USOC</u>	
	- Per Termination		
	- Two-Wire	T6E2X	\$24.03
	- Four-Wire	T6E4X	\$200.00
	- WATS Access Line		
	- Per point of termination		
	- Two-Wire with screening and blocking	X2W	\$24.03
	- Four-Wire with screening and blocking	X4W	\$200.00

(B)⁽⁴⁾

(N) (D)
 |
 (D)

⁽¹⁾ Until February 1, 2018, End User channel terminations and their applicable optional features that had not qualified for Phase II, Level 2 pricing flexibility prior to June 1, 2017, will be rated at the price cap rate regardless of the status of the county in which the applicable wire center is located.

⁽²⁾ Optional features for End User channel terminations includes all optional features in Section 7, except for the Transfer Arrangement.

⁽³⁾ Effective November 20, 2019, this Service will no longer be available for purchase by new or existing customers, and service agreements may no longer be renewed. In addition, requests to move, add or change existing service arrangements will not be accepted. Following the expiration of a customer's existing term agreement, service will be provided on a month-to-month basis at the applicable monthly extension rates until the service is discontinued. AT&T currently plans to discontinue this Service on or after June 30, 2024.

⁽⁴⁾ This service has been de-tariffed pursuant to FCC Order No. 17-43, released April 28, 2017. Terms and Conditions for de-tariffed services are available at www.att.com/guidebook.

(N)
 (N)

(This page filed under Transmittal No. 8)

7. Special Access Service (Cont'd)
 7.8 Program Audio Service^{(3) (4)}

7.8.5 Rates and Charges

Only Non-Competitive End User channel terminations and their applicable optional features⁽²⁾ are available in this tariff. (C)
 (C)
 (D)

	USOC	Monthly Rate	Non-Competitive Rates			
			Daily* Rate	Nonrecurring Charge		
				Monthly	Daily	
(A) <u>Channel Termination</u>						
- Per Termination						
- 200 to 3500 Hz	T6ECS	\$25.00	\$4.00	\$289.75		\$289.75
- 100 to 5000 Hz	T6ECS	28.00	4.00	289.75		289.75
- 50 to 8000 Hz	T6ECS	30.00	4.00	289.75		289.75
- 50 to 15000 Hz	T6ECS	110.00	12.00	289.75		289.75

(B)⁽⁵⁾ (N) (D)

* Daily rates will be topped and maximum rates derived as set forth in 7.2.2.(B) preceding.

(1) Until February 1, 2018, End User channel terminations and their applicable optional features that had not qualified for Phase II, Level 2 pricing flexibility prior to June 1, 2017, will be rated at the price cap rate regardless of the status of the county in which the applicable wire center is located.

(2) Optional features for End User channel terminations includes all optional features in Section 7, except for the Transfer Arrangement.

(3) Effective November 20, 2019, this Service will no longer be available for purchase by new or existing customers, and service agreements may no longer be renewed. In addition, requests to move, add or change existing service arrangements will not be accepted. Following the expiration of a customer's existing term agreement, service will be provided on a month-to-month basis at the applicable monthly extension rates until the service is discontinued. AT&T currently plans to discontinue this Service on or after November 1, 2020.

(4) Program Audio is discontinued and no longer available in this publication (see WC Dkt. 19-238).

(5) This service has been de-tariffed pursuant to FCC Order No. 17-43, released April 28, 2017. Terms and Conditions for de-tariffed services are available at www.att.com/guidebook. (N)
 (N)

(This page filed under Transmittal No. 8)

ACCESS SERVICE

7. Special Access Service (Cont'd)

7.9 Video Service (Cont'd)

7.9.4 Rates and Charges

Only Non-Competitive End User channel terminations and their applicable optional features⁽²⁾ are available in this tariff.

(C)
 (C)
 (D)
 |
 (D)
 (N)

		<u>Non-Competitive Rates</u>			
		<u>Monthly Rate</u>	<u>Daily* Rate</u>	<u>Nonrecurring Charge</u>	
<u>USOC</u>	<u>Monthly</u>			<u>Monthly</u>	<u>Daily</u>
(A)	<u>Channel Termination</u>				
	(1) Analog				
	- Per Termination				
	- TV-1 ⁽³⁾ or 2	TMEV1 \$450.00	\$125.00	\$250.00	\$250.00
	- 4TV-5	TMEV4 \$500.00	\$125.00	\$250.00	\$250.00
	- 6TV-5	TMEV6 \$500.00	\$125.00	\$250.00	\$250.00
	- TV-15	TMEV5 \$500.00	\$125.00	\$250.00	\$250.00

(B)⁽⁴⁾

(D) (N)
 |
 (D)

* Daily rates will be topped and maximum rates derived as set forth in 7.2.2.(B) preceding.
 (1) Until February 1, 2018, End User channel terminations and their applicable optional features that had not qualified for Phase II, Level 2 pricing flexibility prior to June 1, 2017, will be rated at the price cap rate regardless of the status of the county in which the applicable wire center is located.
 (2) Optional features for End User channel terminations includes all optional features in Section 7, except for the Transfer Arrangement.
 (3) Effective December 31, 2020, Broadcast Video (TV1) service will no longer be available for purchase by new or existing customers, and service agreements may no longer be renewed. In addition, requests to move, add, or change existing service arrangements will not be accepted. Following the expiration of a customer's existing term agreement, service will be provided on a month-to-month basis at the applicable Monthly rate until the service is discontinued. AT&T currently plans to discontinue this Service on or after December 31, 2021.
 (4) This service has been de-tariffed pursuant to FCC Order No. 17-43, released April 28, 2017. Terms and Conditions for de-tariffed services are available at www.att.com/guidebook.

(N)
 (N)

(This page filed under Transmittal No. 8)

7. Special Access Service (Cont'd)

7.10 Digital Data Service⁽³⁾ (Cont'd)

7.10.5 Rates and Charges

Only Non-Competitive End User channel terminations and their applicable optional features⁽²⁾ are available in this tariff.

(C)
(C)
(D)

(D)

Non-Competitive Rates (N)

	<u>USOC</u>	<u>Monthly Rate</u>	<u>Nonrecurring Rates</u>
- Per termination			
- 2.4 kbps	T6ECS	\$ 78.92	\$250.00
- 4.8 kbps	T6ECS	78.92	250.00
- 9.6 kbps	T6ECS	78.92	250.00
-56.0 kbps	T6ECS	78.92	250.00
-64.0 kbps	T6ECS	78.92	250.00

(B) ⁽⁴⁾

(D) (N)

(D)

(1) Until February 1, 2018, End User channel terminations and their applicable optional features that had not qualified for Phase II, Level 2 pricing flexibility prior to June 1, 2017, will be rated at the price cap rate regardless of the status of the county in which the applicable wire center is located.

(2) Optional features for End User channel terminations includes all optional features in Section 7, except for the Transfer Arrangement.

(3) Effective November 20, 2019, this Service will no longer be available for purchase by new or existing customers, and service agreements may no longer be renewed. In addition, requests to move, add or change existing service arrangements will not be accepted. Following the expiration of a customer's existing term agreement, service will be provided on a month-to-month basis at the applicable monthly extension rates until the service is discontinued. AT&T currently plans to discontinue this Service on or after June 30, 2024.

(4) This service has been de-tariffed pursuant to FCC Order No. 17-43, released April 28, 2017. Terms and Conditions for de-tariffed services are available at www.att.com/guidebook.

(N)
(N)

(This page filed under Transmittal No. 8)

7. Special Access Service (Cont'd)

7.11 High Capacity Service (Cont'd)

7.11.4 Optional Features and Functions

(B) (2)

(D) (N)

(D)

(1) Effective November 20, 2019, this Service will no longer be available for purchase by new or existing customers, and service agreements may no longer be renewed. In addition, requests to move, add or change existing service arrangements will not be accepted. Following the expiration of a customer's existing term agreement, service will be provided on a month-to-month basis at the applicable monthly extension rates until the service is discontinued. AT&T currently plans to discontinue this Service on or after June 30, 2024.

(2) Material in this Section has been de-tariffed pursuant to FCC Order No. 17-43, released April 28, 2017. Terms and Conditions for de-tariffed services are available at www.att.com/guidebook.

(N)

(N)

(This page filed under Transmittal No. 8)

Issued: November 20, 2024

Effective: December 5, 2024

Four AT&T Plaza, Dallas, Texas 75202

7. Special Access Service (Cont'd)

7.11 High Capacity Service (Cont'd)

7.11.4 Optional Features and Functions (Cont'd)

(2)

(D)

(D)

* Available only on a channel of 1.544 Mbps facility to a Telephone Company DDS hub.

⁽¹⁾ Effective November 20, 2019, this Service will no longer be available for purchase by new or existing customers, and service agreements may no longer be renewed. In addition, requests to move, add or change existing service arrangements will not be accepted. Following the expiration of a customer's existing term agreement, service will be provided on a month-to-month basis at the applicable monthly extension rates until the service is discontinued. AT&T currently plans to discontinue this Service on or after June 30, 2024.

⁽²⁾ Material in this Section has been de-tariffed pursuant to FCC Order No. 17-43, released April 28, 2017. Terms and Conditions for de-tariffed services are available at www.att.com/guidebook.

(N)
|
(N)

(This page filed under Transmittal No. 8)

Issued: November 20, 2024

Effective: December 5, 2024

Four AT&T Plaza, Dallas, Texas 75202

7. Special Access Service (Cont'd)

7.11 High Capacity Service (Cont'd)

7.11.4 Optional Features and Functions (Cont'd)

(1)

(D) (N)



(D)

(1) Material in this Section has been de-tariffed pursuant to FCC Order No. 17-43, released April 28, 2017. Terms and Conditions for de-tariffed services are available at www.att.com/guidebook.

(N)
(N)
(N)

(This page filed under Transmittal No. 8)

7. Special Access Service (Cont'd)7.11 High Capacity Service (Cont'd)7.11.5 Rates and Charges General Description

This section contains the specific regulations governing the rates and charges which apply to High Capacity Services.

DS3 High Capacity Service is available under a month-to-month*, one, three or five-year billing period as described in 7.11.5.1 (A), following.^{(1) (2) (3)} If the Utility initiates rate changes resulting in a decrease of rates for an existing DS3 service with a 1 or 3 year billing period,⁽¹⁾ (C) those rate changes will be passed along to the customer. Rate changes resulting in an increase of rates for an existing DS3 service with a 1 or 3-year billing period will not exceed the original rate for that selected billing period. (C)

7.11.5.1 DS3 High Capacity Service Rate DescriptionMonthly Extension Rates

Monthly extension rates are charges that the customer may elect to be converted to at the end of their 1 or 3 -year billing period, until a new billing period is selected or service is disconnected. Monthly extension rates are only available once the billing period has expired. (C)
(D)

(A) DS3 High Capacity Service Billing Period

The billing period establishes the amount of time that rates for a service are stabilized by the Utility.

The following billing periods are available for DS3 High Capacity Services and associated optional features and functions:

- Month-to-Month
- Monthly Extension Rate
- 1 Year (Channel Termination Only)⁽³⁾
- 3 Year (Channel Termination Only)⁽²⁾
-

(D)

- (1) Effective on September 13, 2017, DS3 High Capacity Service 5-year Payment Plans are no longer available, including for any otherwise available renewals, extensions or conversions. Circuits already subject to a DS3 High Capacity Service 5-year Payment Plan, as of September 13, 2017, will continue to be provided under the then-current DS3 High Capacity Service 5-year Payment Plan term for the remainder of that term.
- (2) Effective November 1, 2022, DS1 Term Payment Plan 2- and 3-year and DS3 High Capacity Service 3-year Payment Plans (collectively, Term Plan Services), are no longer available, including conversions. Existing Term Plan Services, as of November 1, 2022, will continue to be provided under the then-current terms, for the remainder of the applicable term.
- (3) Effective January 17, 2024, DS1 Term Payment Plan 1-year and DS3 High Capacity Service 1-year Payment Plans (collectively, Term Plan Services), are no longer available, including conversions. Existing Term Plan Services on January 17, 2024, will continue to be provided for the remainder of the then-current terms.

(This page filed under Transmittal No. 8)

7. Special Access Service (Cont'd)7.11 High Capacity Service (Cont'd)7.11.5.1 DS3 High Capacity Service Rate Description (Cont'd)(A) DS3 High Capacity Service Billing Period (Cont'd)

One month prior to the expiration of the billing period, the customer must select one of the following options:

- (1) Renew the service for a specified period of time as provided in this tariff under the regulations.
- (2) Elect to be converted to monthly extension rates.
- (3) Elect to disconnect the service upon expiration of the billing period.

Extend the service for an additional 12 month⁽¹⁾ period at the current rates for the existing 1 or 3 year billing period. (C)

If the customer does not choose one of the preceding options prior to the expiration date of the commitment period, monthly extension rates will be applied upon expiration of the commitment period.

If a customer selects neither (1) nor (3) preceding, the current regulations for the Month-to-Month rate option will be applied to the Channel Termination upon expiration of the billing period.

Option (1) as described preceding is available to customers if the term plans remain in effect and are not grandfathered. If the term plans are grandfathered and the service expires, absent customer notification, the customers expired service will be converted to monthly extension rates upon expiration.

The customer must provide the Telephone Company with a written notice of intent to extend the DS3 billing period no later than one month prior to the expiration of the service period.

(1) Effective January 17, 2024, DS1 Term Payment Plan 1-year and DS3 High Capacity Service 1-year Payment Plans (collectively, Term Plan Services), are no longer available, including conversions. Existing Term Plan Services on January 17, 2024, will continue to be provided for the remainder of the then-current terms.

(This page filed under Transmittal No. 8)

7. Special Access Service (Cont'd)7.11 High Capacity Service (Cont'd)7.11.5 Rates and Charges General Description (Cont'd)7.11.5.1 DS3 High Capacity Service Rate Description^{(1) (2)}
(Cont'd)(A) DS3 High Capacity Service Billing Period (Cont'd)

No nonrecurring charges will apply as long as the same number of DS3s is renewed. Any change in the number of DS3s will incur appropriate nonrecurring charges.

The customer may elect to extend an existing DS3 under a 1 or 3 year billing period for a single, additional 12 month period at the current rates for the existing billing period provided the same number of DS3 circuits are being extended. (C)

If the current DS3 rates are lower than the original DS3 rates, the lower rate will be charged.

The customer must provide the Utility with a written notice of intent to extend the DS3 billing period no later than one month prior to the expiration of the service period.

An existing DS3 under a 1 or 3 year billing period may be converted to a DS3 under a longer term 3-year billing period without termination liabilities, provided that: (D)

- (1) the expiration date for the new term agreement is beyond the end of the original term agreements,
- (2) the converted DS3 must be based upon the rates that are currently in effect and otherwise available to all customers,
- (3) the customer maintains the same or greater number of DS3 circuits under the new billing period, and
- (4) No lapse in service occurs.

- (x) Issued under authority of Special Permission No. 14-001 of the FCC in order to withdraw material filed under Transmittal No. 254 and suspended under Order DA-13-2349, released December 9, 2013, without its becoming effective and to restore currently effective material.
- (1) Effective November 1, 2022, DS1 Term Payment Plan 2- and 3-year and DS3 High Capacity Service 3-year Payment Plans (collectively, Term Plan Services), are no longer available, including conversions. Existing Term Plan Services, as of November 1, 2022, will continue to be provided under the then-current terms, for the remainder of the applicable term.
 - (2) Effective January 17, 2024, DS1 Term Payment Plan 1-year and DS3 High Capacity Service 1-year Payment Plans (collectively, Term Plan Services), are no longer available, including conversions. Existing Term Plan Services on January 17, 2024, will continue to be provided for the remainder of the then-current terms.

(This page filed under Transmittal No. 8)

Issued: November 20, 2024

Effective: December 5, 2024

Four AT&T Plaza, Dallas, Texas 75202

7. Special Access Service (Cont'd)

7.11 High Capacity Service (Cont'd)

7.11.5 Rates and Charges General Description (Cont'd)

7.11.5.1 DS3 High Capacity Service Rate Description^{(1) (2)} (Cont'd)

(B) DS3 High Capacity Service Termination Charges

In the event service is terminated prior to the expiration of the billing period, termination charges will apply. Termination charges do not apply to Month-to-Month service. In the event service is terminated prior to the end of the billing period, a termination charge utilizing the following termination percentage will apply:

<u>Billing Period</u>	Termination	<u>Percentage</u>	
1 or 3-year		45%	(C)

The termination charge is calculated as follows:

Monthly Rate x $\frac{\text{Months Remaining in Billing Period}}{\text{Termination Percentage}}$

Example: A customer with a \$5,000 monthly rate terminates service with 10 months remaining in a 3 year billing period. The termination charge would be calculated as follows:

$$\$5,000 \times 10 \times .45 = \$22,500$$

The termination charge would be: \$22,500

- (2) Customers requesting the termination of a DS3 under a 1 or 3-year billing period prior to the expiration date of an extension of service will be charged a termination charge calculated as follows: (C)

Number of Months Utilized of the Extension of Service	X	Current Month To Month Rate	-	Billing Period Monthly Rate
---	---	-----------------------------	---	-----------------------------

- (3) When a DS3 High Capacity Service, which is billed under the Shared Use provision is terminated, the termination liability will be based on the full charges as listed in 7.11.5.2 following.

- (4) A termination charge will not apply if the customer modifies service as set forth in 7.2.3 (Moves), preceding, as long as the customer maintains the same or greater number of DS3 circuits.

- (x) Issued under authority of Special Permission No. 14-001 of the FCC in order to withdraw material filed under Transmittal No. 254 and suspended under Order DA-13-2349, released December 9, 2013, without its becoming effective and to restore currently effective material.
- (1) Effective November 1, 2022, DS1 Term Payment Plan 2- and 3-year and DS3 High Capacity Service 3-year Payment Plans (collectively, Term Plan Services), are no longer available, including conversions. Existing Term Plan Services, as of November 1, 2022, will continue to be provided under the then-current terms, for the remainder of the applicable term.
- (2) Effective January 17, 2024, DS1 Term Payment Plan 1-year and DS3 High Capacity Service 1-year Payment Plans (collectively, Term Plan Services), are no longer available, including conversions. Existing Term Plan Services on January 17, 2024, will continue to be provided for the remainder of the then-current terms.

(x) Issued under authority of Special Permission No. 24-006 of the FCC in order to withdraw material filed under Transmittal No. 2 and Transmittal No. 4.

(This page filed under Transmittal No. 8)

7. Special Access Service (Cont'd)

7.11 High Capacity Service (Cont'd)

7.11.5.2 DS1 Term Payment Plan (DS1 TPP)

(A) General Description

The DS1 Term Payment Plan (DS1 TPP) is a term plan that allows a customer to purchase DS1 High Capacity Service over a 1, 2, 3, or 7 year period. ⁽¹⁾ ⁽²⁾ ⁽³⁾ During the term of the selected DS1 TPP, Telephone Company initiated recurring rate changes (increases or decreases) will automatically be applied to the monthly payments for the remaining months of the current DS1 TPP term. The monthly recurring rate during the DS1 TPP term will never exceed the initial DS1 TPP rate. The DS1 TPP rates can be found in Section 7.11.5.3 following. (D)

The DS1 TPP cannot be combined with other tariffed services, discounts, or pricing flexibility contracts, unless explicitly stated in the respective tariff terms and conditions.

The following recurring rate elements are included in the DS1 TPP as described in 7.2 (Rate Regulations):

- DS1 High Capacity Service Channel Termination;

(D)
|
(D)

- (1) Effective on September 13, 2017, DS1 TPP 5- and 7-year Payment Plans are no longer available, including for any otherwise available conversions. Circuits already subject to a DS1 TPP 5- or 7-year Payment Plan, as of September 13, 2017, will continue to be provided under the then-current DS1 TPP 5- and 7-year Payment Plan term for the remainder of that term.
- (2) Effective November 1, 2022, DS1 Term Payment Plan 2- and 3-year and DS3 High Capacity Service 3-year Payment Plans (collectively, Term Plan Services), are no longer available, including conversions. Existing Term Plan Services, as of November 1, 2022, will continue to be provided under the then-current terms, for the remainder of the applicable term.
- (3) Effective January 17, 2024, DS1 Term Payment Plan 1-year and DS3 High Capacity Service 1-year Payment Plans (collectively, Term Plan Services), are no longer available, including conversions. Existing Term Plan Services on January 17, 2024, will continue to be provided for the remainder of the then-current terms.

(This page filed under Transmittal No. 8)

7. Special Access Service (Cont'd)

7.11 High Capacity Service (Cont'd)

7.11.5.2 DS1 Term Payment Plan (DS1 TPP) (Cont'd)

(C) Moves (Cont'd)

Moves to a different wire center may result in a change in the application of the rate elements associated with the service and therefore could result in a change in the monthly recurring charges.

(D)



(D)

If no lapse in service occurs and if the requirements in (1) and (2) as stated previously are met, termination liability will not apply. Nonrecurring Channel Termination Charges or Nonrecurring Collocation Transport Charges for the physical move will apply.

(D) Expiration of DS1 TPP Term options

DS1 TPP is not available for renewal. At the expiration of the DS1 TPP term, the customer may select a new DS1 TPP term at the prevailing DS1 TPP rates. If a customer does not wish to purchase a new DS1 TPP at the expiration of the term, the customer's service will automatically convert to the current month-to-month rates.

(This page filed under Transmittal No. 8)

7. Special Access Service (Cont'd)

7.11 High Capacity Service (Cont'd)

7.11.5 Rates and Charges General Description (Cont'd)

7.11.5.3 Rates and Charges^{(1) (4) (5)}

Only Non-Competitive End User channel terminations and their applicable optional features⁽²⁾ are available in this tariff. (C)
 (C)
 (D)

(D)
 (D)
 (D)

Rates Non-Competitive (N)

(A) Channel Termination (Per Point of Termination)	<u>USOC</u>	<u>Monthly Rate</u>	<u>Nonrecurring Charges</u>
- 1.544 Mbps	TMECS	\$156.02 ⁽⁶⁾	\$450.00
- 3.152 Mbps	TWT++	ICB	ICB
- 6.312 Mbps	TWT++	ICB	ICB
-44.736 Mbps (Month-to-Month)	Z3MAC/Z3MAP	\$2,358.75	\$1,500.00
-44.736 Mbps (Monthly Extension)	Z3MAC/Z3MAP	\$2,358.75	\$1,500.00
-44.736 Mbps (1 Year Plan)	Z3MAC/Z3MAP/Z31A+	\$1,609.50	\$1,000.00
-44.736 Mbps (3 Year Plan)	Z3MAC/Z3MAP/Z33A+	\$870.00	\$1,000.00

(D)
 (D)
 (N)
 (D)

(7)

- (1) Effective on September 13, 2017, DS3 High Capacity Service 5-year Payment Plans are no longer available, including for any otherwise available renewals, extensions or conversions. Circuits already subject to a DS3 High Capacity Service 5-year Payment Plan, as of September 13, 2017, will continue to be provided under the then-current DS3 High Capacity Service 5-year Payment Plan term for the remainder of that term.
- (2) Until February 1, 2018, End User channel terminations and their applicable optional features that had not qualified for Phase II, Level 2 pricing flexibility prior to June 1, 2017, will be rated at the price cap rate regardless of the status of the county in which the applicable wire center is located.
- (3) Optional features for End User channel terminations includes all optional features in Section 7, except for the Transfer Arrangement.
- (4) Effective November 1, 2022, DS1 Term Payment Plan 2- and 3-year and DS3 High Capacity Service 3-year Payment Plans (collectively, Term Plan Services), are no longer available, including conversions. Existing Term Plan Services, as of November 1, 2022, will continue to be provided under the then-current terms, for the remainder of the applicable term.
- (5) Effective January 17, 2024, DS1 Term Payment Plan 1-year and DS3 High Capacity Service 1-year Payment Plans (collectively, Term Plan Services), are no longer available, including conversions. Existing Term Plan Services on January 17, 2024, will continue to be provided for the remainder of the then-current terms.
- (6) Rate applies to both Month-to-Month and Monthly Extension.
- (7) This Section has been de-tariffed pursuant to FCC Order No. 17-43, released April 28, 2017. Terms and Conditions for de-tariffed services are available at www.att.com/guidebook.

(D)

(N)
 (N)

(This page filed under Transmittal No. 8)

7. Special Access Service (Cont'd)

7.11 High Capacity Service

7.11.5 Rates and Charges General Description (Cont'd)

7.11.5.3 Rates and Charges (Cont'd)

	<u>USOC</u>	<u>Monthly Rate</u>	
(C)			(N)
			(D)

(N)

(D)

(D)

(1) [DELETED]

(2) [DELETED]

(3) [DELETED]

(4) [DELETED]

(5) [DELETED]

(C)

(C)

(6) Material in this Section has been de-tariffed pursuant to FCC Order No. 17-43, released April 28, 2017. Terms and Conditions for de-tariffed services are available at www.att.com/guidebook.

(N)

(N)

(N)

(This page filed under Transmittal No. 8)

7. Special Access Service (Cont'd)

7.11 High Capacity Service

7.11.5 Rates and Charges General Description (Cont'd)

7.11.5.3 Rates and Charges (Cont'd)

	Monthly	Nonrecurring
	<u>USOC</u>	<u>Rate</u>
	<u>Rate</u>	<u>Rate</u>

(C) Optional Features and Functions⁽⁵⁾ (Cont'd)

(N)

(D)

(D)

(1) [DELETED]

(2) [DELETED]

(3) [DELETED]

(4) [DELETED]

(5) Material in this Section has been de-tariffed pursuant to FCC Order No. 17-43, released April 28, 2017. Terms and Conditions for de-tariffed services are available at www.att.com/guidebook.

(C)

(C)

(N)

(N)

(N)

(This page filed under Transmittal No. 8)

Issued: November 20, 2024

Effective: December 5, 2024

Four AT&T Plaza, Dallas, Texas 75202

ACCESS SERVICE

- 7. Special Access Service (Cont'd)
 - 7.11 High Capacity Service
 - 7.11.5 Rates and Charges General Description (Cont'd)
 - 7.11.5.3 Rates and Charges (Cont'd)

Only Non-Competitive End User channel terminations and their applicable optional features are available in this tariff. (N)
(N)

(F) DS1 Term Payment Plan Non-Competitive Rates and Charges for the DS1 Term Payment Plan (1)(3)(4) (N)
(N)

(1) Channel Termination - Per Point of Termination

USOC	1 Year	2 Year	3 Year	7 Year	(D)
TMECS	\$152.29	\$134.40	\$128.80	\$98.50	(D)

(2) (5) (N)
(D)

(3) Nonrecurring Charges-One Time Charges - Per Point of channel termination (C)

USOC	DESCRIPTION	RATE
TMECS	Channel Termination Nonrecurring Charge	\$ 900.00

(D)

NOTE: Channel Termination Nonrecurring Charges and Collocation Transport Nonrecurring Charges are waived on new installations of DS1 High Capacity Service with a 2, 3, 5, or 7-year DS1 TPP.

- (1) Effective on September 13, 2017, DS1 TPP 5- and 7-year Payment Plans are no longer available, including for any otherwise available conversions. Circuits already subject to a DS1 TPP 5- or 7-year Payment Plan, as of September 13, 2017, will continue to be provided under the then-current DS1 TPP 5- and 7-year Payment Plan term for the remainder of that term.
- (2) Effective November 20, 2019, this Service will no longer be available for purchase by new or existing customers, and service agreements may no longer be renewed. In addition, requests to move, add or change existing service arrangements will not be accepted. Following the expiration of a customer's existing term agreement, service will be provided on a month-to-month basis at the applicable monthly extension rates until the service is discontinued. AT&T currently plans to discontinue this Service on or after June 30, 2024.
- (3) Effective November 1, 2022, DS1 Term Payment Plan 2- and 3-year and DS3 High Capacity Service 3-year Payment Plans (collectively, Term Plan Services), are no longer available, including conversions. Existing Term Plan Services, as of November 1, 2022, will continue to be provided under the then-current terms, for the remainder of the applicable term.
- (4) Effective January 17, 2024, DS1 Term Payment Plan 1-year and DS3 High Capacity Service 1-year Payment Plans (collectively, Term Plan Services), are no longer available, including conversions. Existing Term Plan Services on January 17, 2024, will continue to be provided for the remainder of the then-current terms.
- (5) These services have been de-tariffed pursuant to FCC Order No. 17-43, released April 28, 2017. Terms and Conditions for de-tariffed services are available at www.att.com/guidebook. (N)
(N)

(This page filed under Transmittal No. 8)

7. Special Access Service (Cont'd)

7.12 Fractional DS1 Service⁽¹⁾ (Cont'd)

7.12.1 Rates and Charges - 128, 256, 384, 512, and 768 Kbps

Only Non-Competitive End User channel terminations and their applicable optional features⁽²⁾ are available in this tariff.

(C)
 (C)
 (D)
 (D)
 (D)

(A) Channel Termination

- Per Point of Termination TMECS

Non-Competitive Rates

	Recurring Charges	Nonrecurring Charges	
		1st CKT	Addl CKT

MTM	\$125.00	\$900.00	\$900.00
3 Year	\$115.00	\$900.00	\$900.00

(N)
 (D)
 (D)

(B) ⁽²⁾

(D) (N)
 (D)

(1) Effective October 27, 2016, Fractional DS1 Service is limited to existing Customers for existing service arrangements; no new or additional term commitments of any kind, including any otherwise available renewals, will be available; and no move, add, or change orders will be accepted.

(2) This service has been de-tariffed pursuant to FCC Order No. 17-43, released April 28, 2017. Terms and Conditions for de-tariffed services are available at www.att.com/guidebook.

(N)
 (N)
 (N)

(This page filed under Transmittal No. 8)