

	<u>Page No.</u>	
7. <u>SPECIAL ACCESS SERVICE</u>	7-1	(T)
7.1 <u>General</u>	7-3	
7.1.1 Channel Types	7-3	
7.1.2 Service Descriptions	7-6	
7.1.3 Service Configurations	7-9	
7.1.4 Alternate Use	7-13	
7.1.5 Special Facilities Routing	7-14	
7.1.6 Design Layout Report	7-14	
7.1.7 Acceptance Testing	7-14	
7.1.8 Ordering Options and Conditions	7-15	
7.2 <u>Rate Regulations</u>	7-16	
7.2.1 Rate Categories	7-16	
7.2.2 Types of Rates and Charges	7-21	
7.2.3 Moves	7-27	
7.2.4 Minimum Periods	7-27	
7.2.5 Mileage Measurement	7-28	(T)
7.2.6 Facility Hubs	7-29	
7.2.7 Shared Use Analog and Digital High Capacity Services	7-31	
7.2.8 Extension of WATS Access Service	7-33	
7.3 <u>Surcharge for Special Access Service</u>	7-34	
7.3.1 General	7-34	
7.3.2 Application	7-34	
7.3.3 Exemption of Special Access Service	7-35	
7.3.4 Rate Regulations	7-36	
7.3.5 Rate	7-38	
7.4 <u>Message Station Equipment Recovery Charge</u>	7-39	
7.4.1 General	7-39	
7.4.2 Rate	7-39	
7.5 <u>Reserved for Future Use</u>	7-40	(T)
7.6 <u>Reserved for Future Use</u>	7-41	(T)

(This page filed under Transmittal No. 265)

ACCESS SERVICE

Page No.

7. <u>SPECIAL ACCESS SERVICE</u> (Cont'd)		
7.7 <u>Voice Grade Service</u>	7-43	
7.7.1 Basic Channel Description	7-43	
7.7.2 Technical Specifications Packages	7-43	
7.7.3 Channel Interface	7-44	
7.7.4 Optional Features and Functions	7-44	
7.7.5 WATS Access Line (WAL) Service	7-53	
7.7.6 Rates and Charges	7-56	
7.8 <u>Program Audio Service</u> ⁽¹⁾	7-62	(N)
7.8.1 Basic Channel Description	7-62	
7.8.2 Technical Specifications Packages	7-62	
7.8.3 Channel Interfaces	7-62	
7.8.4 Optional Features and Functions	7-63	
7.8.5 Rates and Charges	7-64	
7.9 <u>Video Service</u>	7-66	
7.9.1 Basic Channel Description	7-66	
7.9.2 Technical Specifications Packages	7-67	
7.9.3 Channel Interfaces	7-68	
7.9.4 Rates and Charges	7-69	
7.10 <u>Digital Data Service</u>	7-70	
7.10.1 Basic Channel Description	7-70	
7.10.2 Technical Specifications Packages	7-71	
7.10.3 Channel Interfaces	7-72	
7.10.4 Optional Features and Functions	7-72	
7.10.5 Rates and Charges	7-73	
7.11 <u>High Capacity Service</u>	7-75	
7.11.1 Basic Channel Description	7-75	
7.11.2 Technical Specifications Packages	7-75	
7.11.3 Channel Interfaces	7-76	
7.11.4 Optional Features and Functions	7-76	
7.11.5 Rates and Charges General Description	7-79	
7.11.5.1 DS3 High Capacity Service Rate Description	7-79	
7.11.5.2 DS1 Term Payment Plan (DS1 TPP)	7-81.1	
7.11.5.3 Rates and Charges	7-82	
7.12 <u>Fractional DS1 Service</u>	7-85	

⁽¹⁾ Program Audio is discontinued and no longer available in this publication (see WC Dkt. 19-238). (N)
(N)

(This page filed under Transmittal No. 337)

ACCESS SERVICE

Page No.

7. SPECIAL ACCESS SERVICE (Cont'd)

7.13 Reserved for Future Use

7-86

(T)

7.14 Individual Case Filings

7-94

(N)

(This page filed under Transmittal No. 265)

Issued: July 18, 2014

Effective: August 2, 2014

Four AT&T Plaza, Dallas, Texas 75202

7. Special Access Service

7.1 General

Special Access Service provides a transmission path to connect customer designated premises*, directly, through a Telephone Company hub or hubs where bridging or multiplexing functions are performed, or to connect a customer designated premises and a WATS Serving Office. Special Access Service includes all exchange access not utilizing Telephone Company end office switches.

The connections provided by Special Access Service can be either analog or digital. Analog connections are differentiated by spectrum and bandwidth. Digital connections are differentiated by bit rate.

Special Access Services are ordered under the Access Order provisions set forth in Section 5. preceding.

Rates and charges for Special Access Service are set forth in Sections 7.7.6, 7.8.5, 7.9.4, 7.10.5, and 7.11.5 following, with the exception of the services provided by the Telephone Company in the Metropolitan Statistical Areas (MSAs) in which the Telephone Company has received Phase II pricing flexibility pursuant to Subpart H of Part 69 of the Commission's Rules. The rates and charges for the Special Access Services in the MSAs that have received Phase II pricing flexibility are set forth in Section 22.

7.1.1 Channel Types

There are seven types of channels used to provide Special Access Services. Each type has its own characteristics. All are subdivided by one or more of the following:

- Transmission specifications,
- Bandwidth,
- Speed (i.e., bit rate),
- Spectrum

Customers can order a basic channel and select from a list of available transmission parameters and channel interfaces those that they desire to meet specific communications requirements.

For purposes of ordering channels, each has been identified as a type of Special Access Service. However, such identification is not intended to limit a customer's use of the channel nor to imply that the channel is limited to a particular use. For example, if a customer's equipment is capable of transmitting voice over a channel that is identified as a Metallic Service in this tariff, there is no restriction against doing so.

* Telephone Company Centrex CO and CO-like switches and Interconnection Chambers for EIS are considered to be a customer designated premises for purposes of this tariff. (D)

(D)
(D)
(D)

(This page filed under Transmittal No. 237)

7. Special Access Service (Cont'd)7.1 General (Cont'd)7.1.1 Channel Types (Cont'd)

Following is a brief description of each type of channel:

Voice Grade⁽²⁾ - a channel for the transmission of analog signals within an approximate bandwidth of 300 to 3000Hz.

Program Audio⁽⁴⁾ - a channel for the transmission of audio signals. The nominal frequency bandwidths are from 200 to 3500 Hz, from 100 to 5000 Hz, from 50 to 8000 Hz, or from 50 to 15000 Hz. (N)

Video⁽³⁾ - a channel for the transmission of standard 525 line 60 field monochrome or National Television Systems Committee color video signal and one or two associated 5 or 15 kHz audio signals. The bandwidth is either 30 Hz to 4.5 MHz or 30 Hz to 6.6 MHz.

Digital Data⁽²⁾ - a channel for the digital transmission of synchronous serial data at rates of 2.4, 4.8, 9.6, 56 or 64 kbps.

High Capacity - a channel for the transmission of isochronous serial digital data at rates of 1.544, 3.152, 6.312, 44.736 or 274.176 Mbps.

(1) Effective November 20, 2019, this Service will no longer be available for purchase by new or existing customers, and service agreements may no longer be renewed. In addition, requests to move, add or change existing service arrangements will not be accepted. Following the expiration of a customer's existing term agreement, service will be provided on a month-to-month basis at the applicable monthly extension rates until the service is discontinued. AT&T currently plans to discontinue this Service on or after November 1, 2020.

(2) Effective November 20, 2019, this Service will no longer be available for purchase by new or existing customers, and service agreements may no longer be renewed. In addition, requests to move, add or change existing service arrangements will not be accepted. Following the expiration of a customer's existing term agreement, service will be provided on a month-to-month basis at the applicable monthly extension rates until the service is discontinued. AT&T currently plans to discontinue this Service on or after June 30, 2024.

(3) Effective December 31, 2020, Broadcast Video (TV1) service will no longer be available for purchase by new or existing customers, and service agreements may no longer be renewed. In addition, requests to move, add, or change existing service arrangements will not be accepted. Following the expiration of a customer's existing term agreement, service will be provided on a month-to-month basis at the applicable Monthly rate until the service is discontinued. AT&T currently plans to discontinue this Service on or after December 31, 2021.

(4) Program Audio is discontinued and no longer available in this publication (see WC Dkt. 19-238). (N)

(N)
(N)

(This page filed under Transmittal No. 337)

7. Special Access Service (Cont'd)7.1 General (Cont'd)7.1.1 Channel Types (Cont'd)

Detailed descriptions of each of the channel types are provided in 7.5 through 7.11 following.

The customer also has the option of ordering Voice Grade and High Capacity facilities (i.e., 1.544 Mbps, 3.152 Mbps, 6.312 Mbps, 44.736 Mbps and 274.176 Mbps) to Telephone Company hubs for multiplexing to individual channels of a lower capacity or bandwidth. Descriptions of the types of multiplexing available at the hubs, as well as the number of individual channels which may be derived from each type of facility are set forth in 7.7 and 7.11 following. Additionally, the customer may specify optional features for the individual channels derived from the facility to further tailor the channel to meet specific communications requirements. Descriptions of the optional features and functions available are set forth in 7.2.1 following.

For example, a customer may order a 3.152 Mbps High Capacity channel from a customer designated premises to a Telephone Company hub for multiplexing to two 1.544 Mbps channels. The 1.544 Mbps channels may be further multiplexed at the same or a different hub to Voice Grade channels or may be extended to other customer designated premises or hubs. Optional features may be added to either the 1.544 Mbps or the Voice Grade channels.

(This page filed under Transmittal No. 1)

7. Special Access Service (Cont'd)7.1 General (Cont'd)7.1.2 Service Descriptions

For the purposes of ordering, the categories of Special Access Service are:

Program Audio^{(1) (4)} (AP)
Video (TV)⁽³⁾
Voice Grade⁽²⁾ (VG)
-WATS Access Line (WAL)
Digital Data⁽²⁾ (DA)
High Capacity (HC)

(N)

Each service consists of a basic channel to which a technical specifications package (customized or predefined), channel interface(s) and, when desired, optional features and functions are added to construct the service desired by the customer. Technical specifications packages and optional features and functions are described in this section. Channel interfaces are described in 15.3 and 15.4 following.

Customized technical specifications packages will be provided where technically feasible. If the Telephone Company determines that the requested parameter specifications are not compatible, the customer will be advised and given the opportunity to change the order.

When a customized channel is ordered the customer will be notified whether Additional Engineering Charges apply. In such cases, the customer will be given an estimate of the hours to be billed before any further action is taken on the order.

- (1) Effective November 20, 2019, this Service will no longer be available for purchase by new or existing customers, and service agreements may no longer be renewed. In addition, requests to move, add or change existing service arrangements will not be accepted. Following the expiration of a customer's existing term agreement, service will be provided on a month-to-month basis at the applicable monthly extension rates until the service is discontinued. AT&T currently plans to discontinue this Service on or after November 1, 2020.
- (2) Effective November 20, 2019, this Service will no longer be available for purchase by new or existing customers, and service agreements may no longer be renewed. In addition, requests to move, add or change existing service arrangements will not be accepted. Following the expiration of a customer's existing term agreement, service will be provided on a month-to-month basis at the applicable monthly extension rates until the service is discontinued. AT&T currently plans to discontinue this Service on or after June 30, 2024.
- (3) Effective December 31, 2020, Broadcast Video (TV1) service will no longer be available for purchase by new or existing customers, and service agreements may no longer be renewed. In addition, requests to move, add, or change existing service arrangements will not be accepted. Following the expiration of a customer's existing term agreement, service will be provided on a month-to-month basis at the applicable Monthly rate until the service is discontinued. AT&T currently plans to discontinue this Service on or after December 31, 2021.
- (4) Program Audio is discontinued and no longer available in this publication (see WC Dkt. 19-238).

(N)
(N)

(This page filed under Transmittal No. 337)

7. Special Access Service (Cont'd)7.1 General (Cont'd)7.1.2 Service Descriptions (Cont'd)

The channel description specifies the characteristics of the basic channel and indicates whether the channel is provided between customer designated premises, between a customer designated premises and a Telephone Company hub where bridging or multiplexing functions are performed, between hubs, or between a customer designated premises and a WATS Serving Office.

- (A) Information pertaining to the technical specifications packages indicates the transmission parameters that are available with each package. This information is displayed in a matrix with the transmission parameters listed down the left side and the packages listed across the top. Each package is identified by a code, e.g., VGC. The first two letters of the code indicate the category of Special Access Service to which the parameters are applicable. These two letter codes are shown above in parentheses following the category of Special Access Service. The letter "C" following the two letter code indicates the technical specifications package for a customized service. The letter "w" following the two letter code indicates the technical specifications package for a voice grade Special Access Service used in the provision of WATS or WATS-type service using a Telephone Company designated WATS Serving Office. A numeric or alpha-numeric designation following the two letter code indicates the specific predefined package. For a customized service, the customer may select any parameters available with that category of service as long as the parameters are compatible. When appropriate, the Technical Reference which contains detailed specifications for the parameters is shown following the matrix.

(This page filed under Transmittal No. 1)

7. Special Access Service (Cont'd)7.1 General (Cont'd)7.1.2 Service Descriptions (Cont'd)

- (B) Channel interfaces at each Point of Termination on a two-point service may be symmetrical or asymmetrical. On a multipoint service they may also be symmetrical or asymmetrical, but communications can only be provided between compatible channel interfaces. Only certain channel interfaces are compatible. These are set forth in 15.3.5 following, in a combination format.
- (C) Only certain channel interface combinations are available with the predefined technical specifications packages. These are delineated in the Technical References set forth in (F) following. When a customized channel is requested, all channel interface combinations available with the specified type of service are available with the customized channel.
- (D) The optional features and functions available with each type of Special Access Service are described in this section. The optional features and functions information also indicates with which technical specifications packages they are available. Such information is displayed in a matrix with the optional feature or function listed down the left side and the technical specifications package listed across the top.
- (E) The Telephone Company will maintain existing transmission specifications on services installed prior to the effective date of this tariff, except that existing services with performance specifications exceeding the standards listed in this provision will be maintained at the performance levels specified in this tariff.

(This page filed under Transmittal No. 1)

7. Special Access Service (Cont'd)

7.1 General (Cont'd)

7.1.2 Service Descriptions (Cont'd)

(F) All services installed after the effective date of this tariff will conform to the transmission specification standards contained in this tariff or in the following Technical References for each category of service:

Voice Grade	TR-NPL-000335	
- WATS Access Line	PUB 41004, Table 4	
Program Audio ⁽²⁾	TR-NPL-000334	
Video ⁽¹⁾	TR-NPL-000337	(N)
Digital Data	TR-NPL-000338	
Digital Data	PUB 62507	
High Capacity	PUB 62310	
High Capacity	PUB 62411	
	TA-TSY-000342	

7.1.3 Service Configurations

There are two types of service configurations over which Special Access Services are provided: two-point service and multipoint service.

(A) Two-Point Service

A two-point service connects two customer designated premises, either on a directly connected basis or through a hub where multiplexing functions are performed, or a customer designated premises and a WATS Serving Office (WSO).

(1) Effective December 31, 2020, Broadcast Video (TV1) service will no longer be available for purchase by new or existing customers, and service agreements may no longer be renewed. In addition, requests to move, add, or change existing service arrangements will not be accepted. Following the expiration of a customer's existing term agreement, service will be provided on a month-to-month basis at the applicable Monthly rate until the service is discontinued. AT&T currently plans to discontinue this Service on or after December 31, 2021.

(2) Program Audio is discontinued and no longer available in this publication (see WC Dkt. 19-238). (N)
(N)

(This page filed under Transmittal No. 337)

7. Special Access Service (Cont'd)

7.1.3 Service Configurations (Cont'd)

(A) Two-Point Service (Cont,d)

Applicable rate elements are:

- Channel Terminations
- Channel Mileage (as applicable)
- optional Features and Functions (when applicable)

A Special Access Surcharge, as set forth in 7.3 following and a Message Station Equipment Recovery Charge, as set forth in 7.4 following, may be applicable.

The following diagram depicts a two-point Voice Grade service connecting two customer designated premises (CDP). The service is provided with C-Type conditioning.

CUSTOMERCUSTOMERCUSTOMERCUSTOMER
DESIGNATEDSERVINGSERVINGDESIGNATED
PREMISESPREMISESPREMISESPREMISES

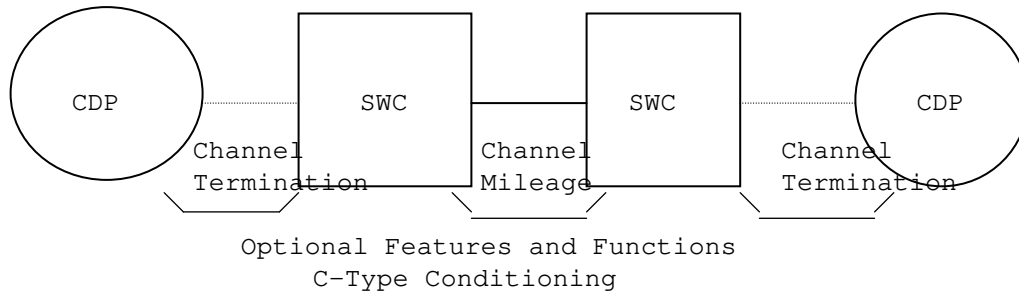

Applicable rate elements are:

- Channel Terminations (applicable one (1) per CDP*)
- Channel Mileage (i section, Channel Mileage Facility per mile plus 2 Channel Mileage Terminations)
- C-Type conditioning Optional Feature

* When CDP is an Interconnection Chamber (See EIS Service Section 18 following) the EIS Channel Termination as described in Section 18 following will apply.

(This page filed under Transmittal No. 1)

7. Special Access Service (Cont'd)7.1 General (Cont'd)7.1.3 Service Configurations (Cont'd)(B) Multipoint Service

Multipoint service connects three or more customer designated premises through one or more Telephone Company hubs. Only certain types of Special Access Service are provided as multipoint service. These are so designated in the descriptions for the appropriate channel.

The channel between hubs (i.e., bridging locations) on a multipoint service is a mid-link. There is no limitation on the number of mid-links available with a multipoint service. However, when more than three mid-links in tandem are provided, the quality of the overall service may be degraded.

Multipoint service utilizing a customized technical specifications package, as set forth in 7.1.2 preceding, will be provided when technically possible. If the Telephone Company determines that the requested characteristics for a multipoint service are not compatible, the customer will be advised and given the opportunity to change the order.

When ordering, the customer will specify the desired bridging hub(s). EXCHANGE CARRIER ASSOCIATION TARIFF F.C.C. NO. 4 identifies serving wire centers, hub locations and the type of bridging functions available.

Applicable Rate Elements are:

- Channel Terminations (one per customer designated premises)

(This page filed under Transmittal No. 1)

7. Special Access Service (Cont'd)

7.1 General (Cont'd)

7.1.3 Service Configurations (Cont'd)

(B) Multipoint Service (Cont'd)

- Channel Mileage (as applicable between the serving wire center for each customer designated premises and the hub and between hubs).
- Bridging
- Additional Optional Features and Functions (when applicable).

The Special Access Surcharge, as set forth in 7.3 following, and a Message Station Equipment Recovery Charge, as set forth in 7.4 following, may be applicable.

Example: Voice Grade multipoint service connecting four customer designated premises (CDP) via two customer specified bridging hubs.

CUSTOMER	CUSTOMER	HUB	CUSTOMER	CUSTOMER
DESIGNATED	SERVING	SERVING	SERVING	DESIGNATED
PREMISES	WIRE CENTER	WIRE CENTER	WIRE CENTER	PREMISES

(T)

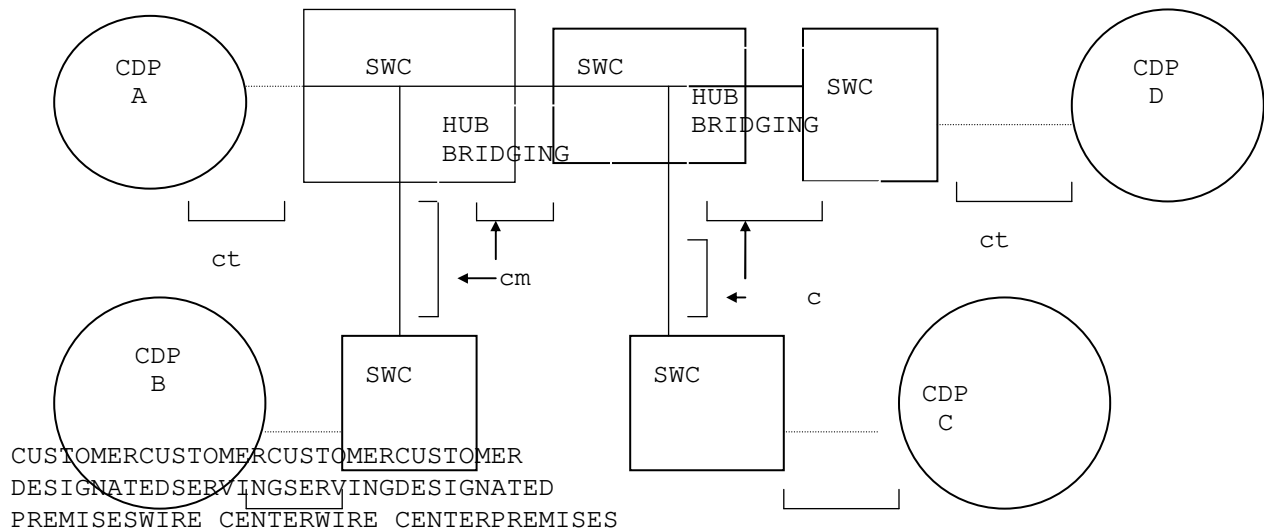

CT - Channel Termination
 CM - Channel Mileage

(This page filed under Transmittal No. 4)

7. Special Access Service (Cont'd)7.1 General (Cont'd)7.1.3 Service Configurations (Cont'd)(B) Multipoint Service (Cont'd)

Applicable rate elements are:

- Channel Terminations (4 applicable)
- Channel Mileage (4 sections, Channel Mileage Facility per mile plus 2 Channel Mileage Terminations per section)
- Bridging Optional Feature (6 applicable, i.e., each bridge port)

7.1.4 Alternate Use

Alternate Use occurs when a service is arranged by the Telephone Company so that the customer can select different types of transmission at different times. A customer may use a service in any privately beneficial manner. However, where technical or engineering changes are required to effectuate an alternate use, the Telephone Company will make such special arrangements available on an individual case basis.

The arrangement required to transfer the service from one operation to the other (i.e., the transfer relay and control leads) will be rated and provided on an individual case basis and filed in Section 12., Specialized Service or Arrangements. The customer will pay the stated tariff rates for the Access Service rate elements for the service ordered (i.e., Channel Terminations, Channel Mileage [as applicable] and Optional Features and Functions [if any]).

(This page filed under Transmittal No. 1)

ACCESS SERVICE
TABLE OF CONTENTS

	<u>Page No.</u>	
7.	7-2	<u>SPECIAL ACCESS SERVICE</u>
7.1	7-3	<u>General</u>
7.1.1	7-3	Channel Types
7.1.2	7-6	Service Descriptions
7.1.3	7-9	Service Configurations
7.1.4	7-13	Alternate Use
7.1.5	7-14	Special Facilities Routing
7.1.6	7-14	Design Layout Report
7.1.7	7-14	Acceptance Testing
7.1.8	7-15	Ordering Options and Conditions
7.2	7-16	<u>Rate Regulations</u>
7.2.1	7-16	Rate Categories
7.2.2	7-21	Types of Rates and Charges
7.2.3	7-27	Moves
7.2.4	7-27	Minimum Periods
7.2.5	7-27	Mileage Measurement
7.2.6	7-29	Facility Hubs
7.2.7	7-31	Shared Use Analog and Digital High Capacity Services
7.2.8	7-33	Extension of WATS Access Service
7.2.9	7-33.1	Video Pricing Plan (VPP)
7.3	7-34	<u>Surcharge for Special Access Service</u>
7.3.1	7-34	General
7.3.2	7-34	Application
7.3.3	7-35	Exemption of Special Access Service
7.3.4	7-36	Rate Regulations
7.3.5	7-38	Rate
7.4	7-39	<u>Message Station Equipment Recovery Charge</u>
7.4.1	7-39	General
7.4.2	7-39	Rate

(N)

(This page filed under Transmittal No. 167)

Issued: September 20, 2007

Effective: October 5, 2007

Four AT&T Plaza, Dallas, Texas 75202

7. Special Access Service (Cont'd)7.1 General (Cont'd)7.1.7 Acceptance Testing (Cont'd)

(B) For other analog services (i.e., Program Audio⁽¹⁾ ⁽⁴⁾, and Video⁽³⁾) and for digital services (i.e., Digital Data⁽²⁾ and High Capacity) service, acceptance tests will include tests for the parameters applicable to the service as specified by the customer in the order for service. (N)

In addition to the above tests, Additional Cooperative Acceptance Testing for Voice Grade⁽²⁾ service to test other parameters, as described in 13.3.5(B) following, is available at the customer's request. All test results will be made available to the customer upon request.

7.1.8 Ordering Options and Conditions

Special Access Service is ordered under the Access Order provisions set forth in 5. preceding. Also included in that section are other charges which may be associated with ordering Special Access Service (e.g., Service Date Change Charges, Cancellation Charges, etc.).

(1) Effective November 20, 2019, this Service will no longer be available for purchase by new or existing customers, and service agreements may no longer be renewed. In addition, requests to move, add or change existing service arrangements will not be accepted. Following the expiration of a customer's existing term agreement, service will be provided on a month-to-month basis at the applicable monthly extension rates until the service is discontinued. AT&T currently plans to discontinue this Service on or after November 1, 2020.

(2) Effective November 20, 2019, this Service will no longer be available for purchase by new or existing customers, and service agreements may no longer be renewed. In addition, requests to move, add or change existing service arrangements will not be accepted. Following the expiration of a customer's existing term agreement, service will be provided on a month-to-month basis at the applicable monthly extension rates until the service is discontinued. AT&T currently plans to discontinue this Service on or after June 30, 2024.

(3) Effective December 31, 2020, Broadcast Video (TV1) service will no longer be available for purchase by new or existing customers, and service agreements may no longer be renewed. In addition, requests to move, add, or change existing service arrangements will not be accepted. Following the expiration of a customer's existing term agreement, service will be provided on a month-to-month basis at the applicable Monthly rate until the service is discontinued. AT&T currently plans to discontinue this Service on or after December 31, 2021. (T)

(4) Program Audio is discontinued and no longer available in this publication (see WC Dkt. 19-238). (N)
(N)

(This page filed under Transmittal No. 337)

ACCESS SERVICE

TABLE OF CONTENTS

	<u>Page No.</u>	
7. <u>SPECIAL ACCESS SERVICE</u> (Cont'd)		
7.9 <u>Video Service</u>	7-66	
7.9.1 Basic Channel Description	7-66	
7.9.2 Technical Specifications Packages	7-67	(T)
7.9.3 Channel Interfaces	7-68	
7.9.4 Rates and Charges	7-69	
7.10 <u>Digital Data Service</u>	7-70	
7.10.1 Basic Channel Description	7-70	
7.10.2 Technical Specifications Packages	7-71	
7.10.3 Channel Interfaces	7-72	
7.10.4 Optional Features and Functions	7-72	
7.10.5 Rates and Charges	7-73	
7.11 <u>High Capacity Service</u>	7-75	
7.11.1 Basic Channel Description	7-75	
7.11.2 Technical Specifications Packages	7-75	
7.11.3 Channel Interfaces	7-76	
7.11.4 Optional Features and Functions	7-76	
7.11.5 Rates and Charges General Description	7-79	
7.11.5.1 DS3 High Capacity Service Rate Description	7-79	
7.11.5.2 Rates and Charges	7-82	
7.12 <u>Individual Case Filings</u>	7-85	
7.13 <u>Gigabit Ethernet Metropolitan Area Network (GigaMAN)</u>	7-86	

(This page filed under Transmittal No. 167)

7. Special Access Service (Cont'd)7.2 Rate Regulations (Cont'd)7.2.1 Rate Categories (Cont'd)(A) Channel Termination

The Channel Termination rate category provides for the communications path between a customer designated premises and the serving wire center of that premises. It also provides for the unrecovered portion of inside wire investment assigned to Special Access Service. Included as part of the Channel Termination is a standard channel interface arrangement which defines the technical characteristics associated with the type of facilities to which the access service is to be connected at the Point of Termination (POT) and the type of signaling capability, if any. The signaling capability is provided as an optional feature as set forth in (C) following. One Channel Termination charge applies per customer designated premises at which the channel is terminated. For WATS Access Line Service, only one Channel Termination applies per service. This charge will apply even if the customer designated premises and the serving wire center are collocated in a Telephone Company building.

(B) Channel Mileage

The Channel Mileage rate category provides for the transmission facilities between the serving wire centers associated with two customer designated premises, between the serving wire centers associated with a customer designated premises and a Telephone Company Hub or between two Telephone Company Hubs. Channel mileage rates are made up of the Channel Mileage Facility rate and the Channel Mileage Termination rate.

(This page filed under Transmittal No. 1)

7. Special Access Service (Cont'd)7.2 Rate Regulations (Cont'd)7.2.1 Rate Categories (Cont'd)(B) Channel Mileage (Cont'd)(1) Channel Mileage Facility

The Channel Mileage Facility rate recovers the cost for the transmission path which extends between the Telephone Company serving wire centers and/or hub(s) and includes primarily outside plant used to provide the facility.

When the customer orders High Capacity Service as described in 7.11 and 7.11.5 following, the Channel Mileage Facility must be ordered in conjunction with an associated Channel Termination as described in 7.2.1.(A), preceding.

(2) Channel Mileage Termination

The Channel Mileage Termination rate recovers the cost for end office equipment associated with terminating the facility (i.e., basic circuit equipment and terminations at serving wire centers and hubs). The Channel Mileage Termination rate will apply at the serving wire center(s) for each customer designated premises and Telephone Company hub where the channel is terminated. If the Channel Mileage is between Telephone Company bridging hubs, the Channel Mileage Termination rate will apply per Telephone Company designated hub. When the Channel Mileage Facility is zero (i.e., collocated serving wire centers), neither the Channel Mileage Facility rate nor the Channel Mileage Termination rate will apply.

(This page filed under Transmittal No. 1)

7. Special Access Service (Cont'd)7.2 Rate Regulations (Cont'd)7.2.1 Rate Categories (Cont'd)(C) Optional Features and Functions

The Optional Features and Functions rate category provides for optional features and functions which may be added to a Special Access Service to improve its quality or utility to meet specific communications requirements. These are not necessarily identifiable with specific equipment, but rather represent the end result in terms of performance characteristics which may be obtained. These characteristics may be obtained by using various combinations of equipment. Although the equipment necessary to perform a specified function may be installed at various locations along the path of the service, they will be charged for as a single rate element.

Examples of Optional Features and Functions that are available include, but are not limited to, the following:

- Signaling Capability
- Hubbing Functions
- Conditioning
- Transfer Arrangements

A hub is a Telephone Company designated serving wire center at which bridging or multiplexing functions are performed. The bridging functions performed are to connect three or more customer designated premises in a multipoint arrangement. The multiplexing functions are to channelize analog or digital facilities to individual services requiring a lower capacity or bandwidth. EXCHANGE CARRIER ASSOCIATION TARIFF F.C.C. NO. 4 identifies serving wire centers, hub locations and the type of bridging or multiplexing functions available.

(This page filed under Transmittal No. 1)

7. Special Access Service (Cont'd)7.2 Rate Regulations (Cont'd)7.2.1 Rate Categories (Cont'd)(C) Optional Features and Functions (Cont'd)

Descriptions for each of the available Optional Features and Functions are set forth in 7.5 through 7.11 following.

(D) Collocation Transport

Collocation Transport provides for the transmission facilities between collocation arrangements located in Telephone Company Central Offices.

There are two components of Collocation Transport.

(1) Inter/Intra Office Fixed

Inter/Intra office fixed rate element provides for the electronic equipment required to terminate a channel between two collocation arrangements located either in the same central office (intra) or in two separate central offices (inter).

When the DS1 Intra Office Fixed channel is ordered between two collocation arrangements that are for the same collocator, it will be provisioned as a temporary arrangement and will be in service until the collocator's own facilities are installed. There is no additional charge to disconnect these temporary facilities. (C)

(2) Inter Office Per Mile

The Per Mile charge provides for the electronic equipment and facilities necessary to provide the interoffice transport between two collocation arrangements.

(This page filed under Transmittal No. 291)

7. Special Access Service (Cont'd)
 7.2 Rate Regulations (Cont'd)
 7.2.2 Types of Rates and Charges

There are three types of rates and charges. These are monthly rates, daily rates and nonrecurring charges. The rates and charges are described as follows:

The rates and charges in effect at the time that the Special Access Service is installed and accepted by the customer are the rates and charges which will be billed to the customer requesting the service. Effective November 1, 2017, Competitive Counties and Non-Competitive Counties have been established and are defined in Section 2.6 and the wire centers within such counties are listed in Sections 17.2(C) and (D). For all rate elements other than End User channel terminations and their applicable optional features,⁽²⁾ price flex rates and charges, as provided in Section 22.5.2, apply, regardless of whether the county is Competitive or Non-Competitive.

For End User channel terminations and their applicable optional features,⁽¹⁾⁽²⁾ the application of "price cap" or "price flex" is dependent upon whether or not the serving wire center is located in a Competitive County. If the End User channel termination is in a Competitive County, price flex rates and charges apply, as provided in Section 22.5.2. If the End User channel termination is in a Non-Competitive County, price cap rates and charges apply, as provided in Section 7.

(A) Monthly Rates

Monthly rates are recurring rates that apply each month or fraction thereof that a Special Access Service is provided. For billing purposes, each month is considered to have 30 days.

(B) Daily Rates

Daily rates are recurring rates that apply to each 24 hour period or fraction thereof that a Program Audio⁽³⁾⁽⁵⁾ or Video⁽⁴⁾ Special Access Service is provided for part-time use. For purposes of applying daily rates, the 24-hour period is not limited to a calendar day.

(N)

Part-time Video⁽⁴⁾ or Program Audio⁽³⁾⁽⁵⁾ Service provided within a consecutive 30 day period will be charged the daily rate, not to exceed an amount equal to the monthly rate. For each subsequent day or part day, a charge equal to 1/30th of the monthly rate shall apply.

(N)

(1) Until February 1, 2018, End User channel terminations and their applicable optional features that had not qualified for Phase II, Level 2 pricing flexibility prior to June 1, 2017, will be rated at the price cap rate regardless of the status of the county in which the applicable wire center is located.

(2) Optional features for End User channel terminations includes all optional features in Section 7, except for the Transfer Arrangement.

(3) Effective November 20, 2019, this Service will no longer be available for purchase by new or existing customers, and service agreements may no longer be renewed. In addition, requests to move, add or change existing service arrangements will not be accepted. Following the expiration of a customer's existing term agreement, service will be provided on a month-to-month basis at the applicable monthly extension rates until the service is discontinued. AT&T currently plans to discontinue this Service on or after November 1, 2020.

(4) Effective December 31, 2020, Broadcast Video (TV1) service will no longer be available for purchase by new or existing customers, and service agreements may no longer be renewed. In addition, requests to move, add, or change existing service arrangements will not be accepted. Following the expiration of a customer's existing term agreement, service will be provided on a month-to-month basis at the applicable Monthly rate until the service is discontinued. AT&T currently plans to discontinue this Service on or after December 31, 2021.

(5) Program Audio is discontinued and no longer available in this publication (see WC Dkt. 19-238).

(N)

(This page filed under Transmittal No. 337)

7. Special Access Service (Cont'd)7.2 Rate Regulations (Cont'd)7.2.2 Types of Rates and Charges (Cont'd)(C) Nonrecurring Charges

Nonrecurring charges are one-time charges that apply for specific work activity (i.e., installation or change to an existing service). The types of nonrecurring charges that apply for Special Access Service are: installation of service, installation of optional features and functions, and service rearrangements.

(1) Installation of Service

Nonrecurring charges apply to each service installed. The nonrecurring charges for the installation of service are set for each channel type as a nonrecurring charge for the Channel Termination.

(2) Installation of Optional Features and Functions

Nonrecurring charges apply for the installation of some of the optional features and functions available with Special Access Service. The charge applies whether the feature or function is installed coincident with the initial installation of service or at any time subsequent to the installation of the service.

The optional features for which nonrecurring charges apply are:

- Voice Grade⁽²⁾ Data Capability
- Voice Grade⁽²⁾ Telephoto Capability
- Program Audio⁽¹⁾⁽³⁾ Gain Conditioning

(N)

(1) Effective November 20, 2019, this Service will no longer be available for purchase by new or existing customers, and service agreements may no longer be renewed. In addition, requests to move, add or change existing service arrangements will not be accepted. Following the expiration of a customer's existing term agreement, service will be provided on a month-to-month basis at the applicable monthly extension rates until the service is discontinued. AT&T currently plans to discontinue this Service on or after November 1, 2020.

(2) Effective November 20, 2019, this Service will no longer be available for purchase by new or existing customers, and service agreements may no longer be renewed. In addition, requests to move, add or change existing service arrangements will not be accepted. Following the expiration of a customer's existing term agreement, service will be provided on a month-to-month basis at the applicable monthly extension rates until the service is discontinued. AT&T currently plans to discontinue this Service on or after June 30, 2024.

(3) Program Audio is discontinued and no longer available in this publication (see WC Dkt. 19-238).

(N)
(N)

(This page filed under Transmittal No. 337)

7. Special Access Service (Cont'd)7.2 Rate Regulations (Cont'd)7.2.2 Types of Rates and Charges (Cont'd)(C) Nonrecurring Charges (Cont'd)(3) Service Rearrangements

Service rearrangements are changes to existing (installed) services which may be administrative only in nature, as set forth following, or that involve actual physical change to the service. Changes to pending orders are set forth in 5.2.2 preceding.

Changes in the physical location of the point of termination or customer designated premises are moves as set forth in 7.2.3 following.

Changes in the type of Service or Channel Termination which result in a change of the minimum period requirement will be treated as a discontinuance of the service and an installation of a new service.

Customers with DS3 service provided under Individual Case Basis (ICB) in other portions of this tariff or with a month-to-month billing period who wish to convert their DS3 service to a 1, 3 or 5 year billing period, may do so without penalty or assessment of new nonrecurring charges, providing there is no physical change in the service arrangement.

Changes in ownership or transfer of responsibility from one customer to another will be treated as a discontinuance of the service and an installation of a new service. In the event the change in ownership or transfer of responsibility as set forth in 2.1.2(A) preceding where there is no change in facilities or arrangements, the change will be treated as an administrative change without charge to the customer.

(This page filed under Transmittal No. 1)

7. Special Access Service (Cont'd)7.2 Rate Regulations (Cont'd)7.2.2 Types of Rates and Charges (Cont'd)(C) Nonrecurring Charges (Cont'd)(3) Service Rearrangements (Cont'd)

(a) Administrative changes will be made without charge(s) to the customer. Administrative changes are as follows:

- Change of customer name,
- Change of customer or customer's end user premises address when the change of address is not a result of a physical relocation of equipment,
- Change in billing data (name, address, or contact name or telephone number),
- Change of agency authorization,
- Change of customer circuit identification,
- Change of billing account number,
- Change of customer test line number,
- Change of customer or customer's end user contact name or telephone number, and
- Change of jurisdiction.

(b) All other service rearrangements will be charged for as follows:

- If the change involves the addition of other customer designated premises to an existing multipoint service, the nonrecurring charge for the channel termination rate element will apply. The charge(s) will apply only for the location(s) that is being added.

(This page filed under Transmittal No. 1)

7. Special Access Service (Cont'd)

7.2 Rate Regulations (Cont'd)

7.2.2 Types of Rates and Charges (Cont'd)

(C) Nonrecurring Charges (Cont'd)

(3) Service Rearrangements (Cont'd)

(b) (Cont'd)

- If the change involves the addition of an optional feature or function which has a separate nonrecurring charge, that nonrecurring charge will apply.
- If the change involves changing the type of signaling on a Voice Grade service, a charge equal to the Voice Grade channel termination rate element nonrecurring charge will apply. The charge will apply per service termination affected.
- If the change involves the rearrangement of existing Voice Grade Service to a Multiplexed High Capacity service and there is no change of customer premises location(s), a charge equal to one-half the Voice Grade channel termination rate element nonrecurring charge will apply. The charge will be per service termination affected.
- Except for moves stated in 7.2.3 following, all other changes, including the addition of optional feature or function without a separate nonrecurring charge, a charge equal to a channel termination nonrecurring charge will apply. Only one such charge will apply per service, per change.
- If a Special Access change involves changing a Multiplexer Cross Connect it will be considered to be a discontinuance and installation of the Multiplexer Cross Connect and all applicable nonrecurring charges shall apply.

(N)
|
(N)

(This page filed under Transmittal No. 17)

7. Special Access Service (Cont'd)7.2 Rate Regulations (Cont'd)7.2.2 Types of Rates and Charges (Cont'd)(C) Nonrecurring Charges (Cont'd)(3) Service Rearrangements (Cont'd)(c) DS1/DS3 Rollover Charges

Rollover Charges are physical changes to, or reclassification of existing service, where there is no change in either point of termination or the Expanded Interconnection Service (EIS) point of termination. Except as noted below, all facilities and equipment required for the activity must already exist. The following are examples where DS1/DS3 Rollover Charges will apply:

- Rearranging an existing Special Access DS1 or DS3 service from one port to another port in the same multiplexer.
- Rearranging an existing Special Access DS1 or DS3 service from one multiplexer to another multiplexer in the same serving wire center.
- Rearranging an exiting Special Access DS1 or DS3 Channel Termination to a port of an existing multiplexed higher speed service in the same serving wire center.
- Rearranging an existing Special Access DS1 or DS3 Channel Termination to an EIS DS1 or DS3 Channel Termination in the same serving wire center.
- Rearranging an existing lower speed service to an existing multiplexed higher speed service.

In the event a change involves a physical move of the point of termination at the customer's premises or a move of the customer's premises, a move charge as set forth in 7.2.3 will apply.

Rollover Charges are set forth in 7.11.5(D) following. No charge will apply for subtending services of the service being rolled over as long as there is no change to the subtending services.

(This page filed under Transmittal No. 1)

7. Special Access Service (Cont'd)
 7.2 Rate Regulations (Cont'd)
 7.2.3 Moves

A move involves a change in the physical location of one of the following:

- The Point of Termination at the customer's premises
- The customer's premises

The charges for the move are dependent on whether the move is to a new location within the same building or to a different building.

(A) Moves Within the Same Building

When the move is to a new location within the same building or a change of connecting facility assignment in the same central office other than DS1 and DS3 rollover rearrangements as described in 7.2.2(C) (3) (c) preceding, the charge for the move will be an amount equal to one half of the nonrecurring (i.e., installation) charge for the service termination affected. There will be no change in the minimum period requirements.

(B) Moves To a Different Building

Moves to a different building will be treated as a discontinuance and start of service and all associated nonrecurring charges will apply. New minimum period requirements will be established for the new services. The customer will also remain responsible for satisfying all outstanding minimum period charges for the discontinued service.

7.2.4 Minimum Periods

The minimum service period for all services is one month, except DS3 High Capacity Service under a 1, 3 or 5-year⁽⁴⁾ billing period, and part-time Video and Program Audio services^{(1) (3)}. (N)

(A) The minimum service period for part-time Video⁽²⁾ and Program Audio^{(1) (3)} services is one day (i.e., a continuous 24-hour period, not limited to a calendar day).

(B) The minimum service period for DS3 (44.746 Mbps) High Capacity Special Access Service is a 1-year⁽⁴⁾ term plan. (N)
 After the 1-, 3-, or 5-year billing period is satisfied, the customer must select a renewal option as referenced in Section 7.11.5.1.

(1) Effective November 20, 2019, this Service will no longer be available for purchase by new or existing customers, and service agreements may no longer be renewed. In addition, requests to move, add or change existing service arrangements will not be accepted. Following the expiration of a customer's existing term agreement, service will be provided on a month-to-month basis at the applicable monthly extension rates until the service is discontinued. AT&T currently plans to discontinue this Service on or after November 1, 2020.

(2) Effective December 31, 2020, Broadcast Video (TV1) service will no longer be available for purchase by new or existing customers, and service agreements may no longer be renewed. In addition, requests to move, add, or change existing service arrangements will not be accepted. Following the expiration of a customer's existing term agreement, service will be provided on a month-to-month basis at the applicable Monthly rate until the service is discontinued. AT&T currently plans to discontinue this Service on or after December 31, 2021.

(3) Program Audio is discontinued and no longer available in this publication (see WC Dkt. 19-238).

(4) Effective January 17, 2024, the 1-year minimum period for DS3 (44.746 Mbps) High Capacity Special Access Service no longer applies. (N)
 (N)

(This page filed under Transmittal No. 342)

7. Special Access Service (Cont'd)7.2 Rate Regulations (Cont'd)7.2.5 Mileage Measurement

The mileage to be used to determine the monthly rate for the Channel Mileage Facility is calculated on the airline distance between the locations involved, i.e., the serving wire centers associated with two customer designated premises, a serving wirecenter associated with a customer designated premises and a Telephone Company hub, two Telephone Company hubs or between the serving wire center associated with a customer designated premises and a WATS Serving Office. The serving wire center associated with a customer designated premises is the serving wire center from which this customer designated premises would normally obtain dial tone.

Mileage charges are shown with each channel type. To determine the rate to be billed, first compute the mileage using the V&H coordinates method, as set forth in the NATIONAL EXCHANGE CARRIER ASSOCIATION TARIFF F.C.C. NO. 4, then multiply the resulting number of miles times the Channel Mileage Facility per mile rate, and add the Channel Mileage Termination rate for each termination. When the calculation results in a fraction of a mile, always round up to the next whole mile before determining the mileage and applying the rates. (T)

When hubs are involved, mileage is computed and rates applied separately for each section of the Channel Mileage, i.e., customer designated premises serving wire center to hub, hub to hub and/or hub to customer designated premises serving wire center. However, when any service is routed through a hub for purposes other than customer specified bridging or multiplexing (e.g., the Telephone Company chooses to so route for test access purposes), rates will be applied only to the distance calculated between the serving wire centers associated with the customer designated premises.

(This page filed under Transmittal No. 4)

7. Special Access Service (Cont'd)7.2 Rate Regulations (Cont'd)7.2.6 Facility Hubs

A customer has the option of ordering Voice Grade⁽²⁾ service or High Capacity services (i.e., DS1, DS1C, DS2, DS3 or DS4) to a facility hub for channelizing to individual services requiring lower capacity facilities (e.g., Voice⁽²⁾, Program Audio^{(1) (3)}, etc.).

(N)

Different locations may be designated as hubs for different facility capacities, e.g., multiplexing from digital to digital may occur at one location while multiplexing from digital to analog may occur at a different location. When placing an Access Order the customer will specify the desired hub. EXCHANGE CARRIER ASSOCIATION TARIFF F.C.C. NO. 4 identifies serving wire centers, hub locations and the type of multiplexing functions available.

Some of the types of multiplexing available include the following:

- from higher to lower bit rate
- from higher to lower bandwidth
- from digital to voice frequency channels

Point to point services may be provided on channels of these services to a hub. The transmission performance for the point to point service provided between customer designated premises will be that of the lower capacity or bit rate. For example, when a 1.544 Mbps channel is multiplexed to voice frequency channels, the transmission performance of the channelized services will be Voice Grade, not High Capacity.

(1) Effective November 20, 2019, this Service will no longer be available for purchase by new or existing customers, and service agreements may no longer be renewed. In addition, requests to move, add or change existing service arrangements will not be accepted. Following the expiration of a customer's existing term agreement, service will be provided on a month-to-month basis at the applicable monthly extension rates until the service is discontinued. AT&T currently plans to discontinue this Service on or after November 1, 2020.

(2) Effective November 20, 2019, this Service will no longer be available for purchase by new or existing customers, and service agreements may no longer be renewed. In addition, requests to move, add or change existing service arrangements will not be accepted. Following the expiration of a customer's existing term agreement, service will be provided on a month-to-month basis at the applicable monthly extension rates until the service is discontinued. AT&T currently plans to discontinue this Service on or after June 30, 2024.

(3) Program Audio is discontinued and no longer available in this publication (see WC Dkt. 19-238).

(N)
(N)

(This page filed under Transmittal No. 337)

7. Special Access Service (Cont'd)7.2 Rate Regulations (Cont'd)7.2.6 Facility Hubs (Cont'd)

The Telephone Company will commence billing the monthly rate for the service to the hub on the date specified by the customer on the Access Order. Individual channels utilizing these services may be installed coincident with the installation of the service to the hub or may be ordered and/or installed at a later date, at the option of the customer. The customer will be billed for a Voice Grade or a High Capacity Channel Termination, Channel Mileage (when applicable), and the multiplexer at the time the service is installed. Individual service rates (by service type) will apply for a Channel Termination and additional Channel Mileage (as required) for each channelized service. These will be billed to the customer as each individual service is installed.

Cascading multiplexing occurs when a High Capacity service is de-multiplexed to provide channels with a lesser capacity and one of the lesser capacity channels is further de-multiplexed. For example, a 6.312 Mbps High Capacity service is de-multiplexed to four DS1 channels and then one of the DS1 channels is further de-multiplexed to 24 individual Voice Grade channels.

When cascading multiplexing is performed, whether in the same or a different hub, a charge for the additional multiplexing unit also applies. When cascading multiplexing is performed at different hubbing locations, Channel Mileage charges also apply between the hubs.

(This page filed under Transmittal No. 1)

7. Special Access Service (Cont'd)7.2 Rate Regulations (Cont'd)7.2.6 Facility Hubs (Cont'd)

The Telephone Company will designate hubs for Video⁽¹⁾ and Program Audio⁽²⁾ Services. Full-time or part-time service may be provided between customer designated premises or between a customer designated premises and a hub and billed accordingly at the monthly rates set forth in 7.8 and 7.9 following for a Channel Termination, Channel Mileage and Optional Features and Functions, as applicable. When the service is ordered to a hub, the customer may order a full-time or part-time Video and Program Audio⁽²⁾ services as needed between that hub and additional customer designated premises. The rate elements required to provide the part-time service (i.e., Channel Termination, Channel Mileage and Optional Features and Functions, as applicable) will be billed at daily rates for the duration of the service requested. (N)

7.2.7 Shared Use Analog and Digital High Capacity Services

Shared use refers to a rate application applicable only when the customer orders High Capacity facilities between a customer designated premises and a Telephone Company hub where the Telephone Company performs multiplexing/demultiplexing functions and the same customer then orders the derived channels as Special and Switched Access Services.

The High Capacity facility will be ordered, provided and rated as Special Access Service (i.e., Channel Termination, Channel Mileage, as appropriate, and Multiplexing Arrangement). The nonrecurring charge that applies when the shared use facility is installed will be the nonrecurring charge associated with the appropriate Special Access High Capacity Channel Termination. Rating as Special Access will continue until such time as the customer chooses to use a portion of the available capacity for Switched Access Service. Individual service (i.e., Switched or Special Access) nonrecurring charges will not apply to the individual channels of the shared use facility.

Shared use is permitted with Expanded Interconnection Service described in Section 18.1.2 following.

(1) Effective December 31, 2020, Broadcast Video (TV1) service will no longer be available for purchase by new or existing customers, and service agreements may no longer be renewed. In addition, requests to move, add, or change existing service arrangements will not be accepted. Following the expiration of a customer's existing term agreement, service will be provided on a month-to-month basis at the applicable Monthly rate until the service is discontinued. AT&T currently plans to discontinue this Service on or after December 31, 2021.

(2) Program Audio is discontinued and no longer available in this publication (see WC Dkt. 19-238).

(This page filed under Transmittal No. 337)

7. Special Access Service (Cont'd)7.2 Rate Regulations (Cont'd)7.2.7 Shared Use Analog and Digital High Capacity Services
(Cont'd)

When Special Access Service is provided utilizing a channel of the shared use facility to a hub, High Capacity rates and charges will apply for the facility to the hub, as set forth preceding, and individual service rates and charges will apply from the hub to the customer designated premises. The rates and charges that will apply to the portion from the hub to the customer designated premises will be dependent on the specific type of Special Access Service that is provided (e.g., Voice Grade⁽¹⁾, Telegraph⁽¹⁾, etc.). The applicable rates and charges will include a Channel Termination and Channel Mileage, if applicable. Rates and charges for optional features and functions associated with the service, if any, will apply for the appropriate channel type. (N)

As each individual channel is activated for Switched Access Service, the High Capacity Special Access Channel Termination and Channel Mileage rates will be reduced accordingly (e.g., 1/24th for a DS1service, 1/672nd for DS-3 service, etc.). In addition, if multiplexing is associated with the service under optional features and functions, the multiplexor rate will also be reduced accordingly. Switched Access Service rates and charges, as set forth in 6.8 preceding, will apply for each channel of the shared use facility that is used to provide a Switched Access Service.

The customer must place an order for each individual Switched or Special Access Service utilizing the Shared Use Facilities and specify the channel assignment for each such service.

⁽¹⁾ Effective November 20, 2019, this Service will no longer be available for purchase by new or existing customers, and service agreements may no longer be renewed. In addition, requests to move, add or change existing service arrangements will not be accepted. Following the expiration of a customer's existing term agreement, service will be provided on a month-to-month basis at the applicable monthly extension rates until the service is discontinued. AT&T currently plans to discontinue this Service on or after June 30, 2024. (N)

(This page filed under Transmittal No. 318)

ACCESS SERVICE

7. Special Access Service (Cont'd)7.2 Rate Regulations (Cont'd)7.2.8 Extension of WATS Access Service

WATS Access Service is available with extensions, i.e., additional terminations, of the service at different customer designated premises in the same or different LATAs. Extensions are provided and charged for as separate Voice Grade⁽²⁾ Special Access Service. The rate elements which apply are: WATS Access Line Channel Termination, Channel Mileage, if applicable, and Signaling Capability (Optional Features and Functions), if applicable. All appropriate charges as set forth in 7.7.6 following will apply. (N)

7.2.9⁽¹⁾

⁽¹⁾ Material in this Section has been de-tariffed as required by the Commission upon use of the forbearance relief pursuant to FCC Memorandum Opinion and Order No. 07-180, released October 12, 2007. Terms and Conditions associated with de-tariffed services are available at www.att.com/guidebook.

⁽²⁾ Effective November 20, 2019, this Service will no longer be available for purchase by new or existing customers, and service agreements may no longer be renewed. In addition, requests to move, add or change existing service arrangements will not be accepted. Following the expiration of a customer's existing term agreement, service will be provided on a month-to-month basis at the applicable monthly extension rates until the service is discontinued. AT&T currently plans to discontinue this Service on or after June 30, 2024. (N)

(This page filed under Transmittal No. 318)

Issued: November 5, 2019

Effective: November 20, 2019

Four AT&T Plaza, Dallas, Texas 75202

ACCESS SERVICE

7. Special Access Service (Cont'd)

7.2 Rate Regulations (Cont'd)

7.2.9⁽¹⁾

(D)

⁽¹⁾ See footnote (1) on page 7-33.

(This page filed under Transmittal No. 176)

Issued: January 24, 2008

Effective: February 8, 2008

675 W. Peachtree St. NW, Atlanta, GA 30308

7. Special Access Service (Cont'd)7.3 Surcharge for Special Access Service7.3.1 General

Special access services provided under this tariff may be subject to the monthly Special Access Surcharge.

7.3.2 Application

(A) The Special Access Surcharge will apply to each interstate Special Access Service that terminates on an end user's PBX or other device where, through a function of the device, the Special Access Service interconnects to the local exchange network. Interconnection functions include, but are not limited to, wiring and software functions, bridging, switching or patching of calls or stations. The Surcharge will apply irrespective of whether the interconnection function is performed in equipment located at the customer's premises or in a Centrex Co-type switch.

(T)

(B) Special Access Service will be exempted from the Surcharge by the Telephone Company upon receipt of the customer's written certification for the following Special Access Service terminations:

- (1) an open-end termination in a Telephone Company switch of an FX line, including CCSA and CCSA-equivalent ONALs; or
- (2) an analog channel termination that is used for radio or television program transmission; or
- (3) a termination used for TELEX service; or
- (4) a termination that by the nature of its operating characteristics could not make use of Telephone Company common lines such as, terminations which are restricted through hardware or software; or

(This page filed under Transmittal No. 4)

7. Special Access Service (Cont'd)7.3 Surcharge for Special Access Service (Cont'd)7.3.2 Application (Cont'd)

(B) (Cont'd)

- (5) a termination that interconnects either directly or indirectly to the local exchange network where the usage is subject to Carrier Common Line charges such as, where the Special Access Service accesses only FGA and no local exchange lines, or Special Access Service between customer points of termination, or Special Access Service connecting CCSA or CCSA-type equipment (inter-machine trunks); or
- (6) a termination that the customer certifies to the Telephone Company is not connected to a PBX or other device which interconnects the Special Access Service to a local exchange subscriber line.

7.3.3 Exemption of Special Access Service

- (A) Special Access Services which are terminated as set forth in 7.3.2(B) preceding will be exempted from the Special Access Surcharge if the customer provides the Telephone Company with written exemption certification. The certification may be provided to the Telephone Company (1) at the time the Special Access Service is ordered or installed; (2) at such time as the service is reterminated to a device which does not interconnect to the service to local exchange facilities, or (3) at such time as the service becomes associated with a Switched Access Service that is subject to Carrier Common Line Charges.

(This page filed under Transmittal No. 1)

7. Special Access Service (Cont'd)

7.3 Surcharge for Special Access Service (Cont'd)

7.3.3 Exemption of Special Access Service (Cont'd)

- (B) The exemption certification is to be provided by the customer ordering the service. The certification must be signed by the customer or authorized representative and include the category of exemption, as set forth in 7.3.2(B) preceding, for each termination, and the date which the exemption is effective.
- (C) The customer shall also notify the Telephone Company when an exempted Special Access Service is changed or reterminated such that the exemption is no longer applicable.
- (D) The Telephone Company will work cooperatively with the customer to resolve any questions regarding the exemption certification. In addition, the Telephone Company may withhold exemption of the service until the questions are resolved.

7.3.4 Rate Regulations

- (A) The Surcharge will apply as set forth in 7.3.2(A) preceding, except that a surcharge will be assessed on a per voice grade equivalent basis for Special Access Services derived from High Capacity Special Access Services as shown in the following example:

<u>Special Access Service</u>	<u>Voice Grade Equivalent</u>		<u>Surcharge</u>	=	<u>Monthly Charge</u>
DS1	24	X	\$25.00		\$600.00

In the case of multipoint Special Access Services, one Special Access Surcharge will apply for each termination of a Special Access Channel at an end user's premises.

(This page filed under Transmittal No. 1)

7. Special Access Service (Cont'd)7.3 Surcharge for Special Access Service (Cont'd)7.3.4 Rate Regulations (Cont'd)

(B) The Telephone Company will bill the appropriate Special Access Surcharge to the ordering customer for each interstate Special Access Service installed unless exemption certification is provided as set forth in 7.3.3 preceding.

(C) If a written certification is not received at the time the Special Access Service is obtained, the Surcharge will be applied. Exempt status will become effective on the certification date indicated by the customer, subject to the regulations set forth in (D) following.

(D) Crediting the Surcharge

The Telephone Company will cease billing the Special Access Surcharge when certification, as set forth in 7.3.3 preceding, is received. If the status of the Special Access Service was changed prior to receipt of the exemption certification, the Telephone Company will credit the customer's account, not to exceed ninety (90) days, based on the effective date of the change as specified by the customer in the letter of certification.

(E) Surcharge Payment Deferral Provision

The Telephone Company will bill the surcharge on Special Access facilities in service as of June 1, 1986, used in the provision of WATS or WATS-type service through a Telephone Company designated WATS Serving Office (WSO). Payment of such surcharge may be deferred, without penalty, for up to ninety (90) days from the date of the first bill rendered for the Special Access Surcharge.

(This page filed under Transmittal No. 1)

7. Special Access Service (Cont'd)7.3 Surcharge for Special Access Service (Cont'd)7.3.4 Rate Regulations (Cont'd)

(E) Surcharge Payment Deferral Provision (Cont'd)

If appropriate exemption certification is not received by the Telephone Company by the end of the ninety (90) days deferral period, the billed Special Access Surcharge will become due. These charges, if unpaid, will be subject to a late payment charge as set forth in Section 2.4.1(B) (2) preceding.

7.3.5 Rate

	<u>USOC</u>	<u>Monthly Rate</u>
Surcharge for Special Access Service - Per Voice Grade Equivalent	S25	\$25.00

(This page filed under Transmittal No. 1)

Issued: February 16, 2001

Effective: March 3, 2001

Four AT&T Plaza, Dallas, Texas 75202

7. Special Access Service (Cont'd)

7.4 Message Station Equipment Recovery Charge

7.4.1 General

The Message Station Equipment Recovery Charge is a charge to recover that portion of message station equipment that is assigned to Special Access Service.

Pursuant to CC Docket 83-1145 Memorandum Opinion and Order adopted by the Federal Communications Commission on November 8, 1984, and released on November 9, 1984, this charge is assessed only to those customers to which the Special Access Surcharge, as set forth in 7.3 preceding, applies.

(T)

7.4.2 Rate

	<u>USOC</u>	<u>Monthly Rate</u>
Message Station Equipment Recovery Charge - Per Special Access Surcharge Assessed	UTM	\$0.00

(This page filed under Transmittal No. 4)

Issued: July 3, 2001

Effective: July 18, 2001

Four AT&T Plaza, Dallas, Texas 75202

7. Special Access Service (Cont'd)

7.5 Reserved for Future Use

(This page filed under Transmittal No. 1)

Issued: February 16, 2001

Effective: March 3, 2001

Four AT&T Plaza, Dallas, Texas 75202

7. Special Access Service (Cont'd)

7.6 Reserved for Future Use

(T)

(This page filed under Transmittal No. 268)

Issued: September 26, 2014

Effective: October 11, 2014

Four AT&T Plaza, Dallas, Texas 75202

7. Special Access Service (Cont'd)

7.6 Reserved for Future Use

(T)

(This page filed under Transmittal No. 268)

Issued: September 26, 2014

Effective: October 11, 2014

Four AT&T Plaza, Dallas, Texas 75202

7. Special Access Service (Cont'd)

7.7 Voice Grade Service⁽¹⁾

(N)

7.7.1 Basic Channel Description

A Voice Grade channel is a channel which provides voice frequency transmission capability in the nominal frequency range of 300 to 3000 Hz and may be terminated two-wire or four-wire. Voice Grade channels are provided between customer designated premises, between a customer designated premises and a Telephone Company hub or hubs, or between a customer designated premises and a WATS Serving Office (WSO).

7.7.2 Technical Specifications Packages

Package VG-

Parameter	C*	1	2	3	4	5	6	7	8	9	10	11	W
Attenuation													
Distortion	X	X	X	X	X	X	X	X	X	X	X	X	X
C-Message Noise	X	X	X	X	X	X	X	X	X	X	X	X	X
Echo Control	X	X	X	X		X		X	X				X
Envelope Delay													
Distortion	X						X	X	X	X	X	X	X
Frequency Shift	X						X	X	X	X	X	X	X
Impulse Noise	X					X	X	X	X	X	X	X	X
Intermodulation													
Distortion	X						X	X	X	X	X	X	X
Loss Deviation	X	X	X	X	X	X	X	X	X	X	X	X	X
Phase Hits, Gain													
Hits, and Dropouts	X												
Phase Jitter	X						X	X	X	X	X	X	X
Signal-to-C													
Message Noise					X								
Signal-to-C													
Notch Noise	X					X	X	X	X	X	X	X	X

* The desired parameters are selected by the customer from the list of available parameters.

⁽¹⁾ Effective November 20, 2019, this Service will no longer be available for purchase by new or existing customers, and service agreements may no longer be renewed. In addition, requests to move, add or change existing service arrangements will not be accepted. Following the expiration of a customer's existing term agreement, service will be provided on a month-to-month basis at the applicable monthly extension rates until the service is discontinued. AT&T currently plans to discontinue this Service on or after June 30, 2024. (N)

(This page filed under Transmittal No. 318)

7. Special Access Service (Cont'd)7.7 Voice Grade Service (Cont'd)7.7.2 Technical Specifications Packages (Cont'd)

The technical specifications for these parameters (except for dropouts, gain hits, and phase hits) are delineated in Technical Reference TR-NPL-000334, TR-NPL-000335 and associated Addendum. The technical specifications for dropouts, phase hits, and gain hits are delineated in Technical Reference PUB 41004, Table 4.

7.7.3 Channel Interfaces

The following channel interfaces for Voice Grade service do not require signaling capability: AH, DA, DB, DM, DS, NO, PR and TF. (D)

The following channel interfaces for Voice Grade service require signaling capability: AB, AC, CT, DX, DY, EA, EB, EC, EX, GO, GS, LA, LB, LC, LO, LR, LS, RV and SF.

Compatible channel interfaces are set forth in Section 15.3, following. (T)

7.7.4 Optional Features and Functions(A) Central Office Bridging Capability

(1) Voice Bridging (two-wire and four-wire)

(2) Data Bridging (two-wire and four-wire)

(This page filed under Transmittal No. 262)

7. Special Access Service (Cont'd)7.7 Voice Grade Service (Cont'd)7.7.4 Optional Features and Functions (Cont'd)(B) Conditioning

Conditioning provides more specific transmission characteristics for Voice Grade services. C-Type conditioning controls attenuation distortion and envelope delay distortion. Sealing Current helps maintain continuity on dry metallic loops.

For two-point services, the parameters apply to each service. For multipoint services, the parameters apply to each mid-link or end link. C-Type conditioning and Data Capability may be combined on the same service.

In addition, a customer may desire that either the attenuation distortion or the envelope delay distortion, or both, be improved to more stringent specifications than those provided for standard C-Type conditioning. In such cases the customer has the option of ordering either Improved Attenuation Distortion or Improved Envelope Delay Distortion, or both, as desired.

(1) C-Type Conditioning

C-Type Conditioning is provided for the additional control of attenuation distortion and envelope delay distortion on data services. The attenuation distortion and envelope delay distortion specifications for C-Type Conditioning are delineated in Technical Reference TR-NPL-000335.

(This page filed under Transmittal No. 1)

ACCESS SERVICE

7. Special Access Service (Cont'd)7.7 Voice Grade Service (Cont'd)7.7.4 Optional Features and Functions (Cont'd)(B) Conditioning (Cont'd)(2) Improved Attenuation Distortion *

Improved Attenuation Distortion upgrades the frequency versus loss limits of the channel. The technical specifications for Improved Attenuation Distortion are delineated in Technical Reference TR-NPL-000335.

(3) Improved Envelope Delay Distortion *

Improved Envelope Delay Distortion upgrades the frequency versus delay Response limits of the channel. The technical specifications for Improved Envelope Delay Distortion are delineated in Technical Reference TR-NPL-000335.

- * Improved Attenuation Distortion and Improved Envelope Delay Distortion will continue to be provided to all customers who were provided with either or both of these optional features in conjunction with C-Type Conditioning prior to September 29, 1988.

(This page filed under Transmittal No. 1)

Issued: February 16, 2001

Effective: March 3, 2001

Four AT&T Plaza, Dallas, Texas 75202

7. Special Access Service (Cont'd)7.7 Voice Grade Service (Cont'd)7.7.4 Optional Features and Functions (Cont'd)(B) Conditioning (Cont'd)(4) Sealing Current Conditioning

Sealing Current Conditioning is provided to help maintain continuity on dry loops. It is usually associated with four-wire DA or NO type channel interfaces.

(C) Customer Specified Premises Receive Level

This option allows the customer to specify the receive level at the Point of Termination. The level must be within a specific range on effective four-wire transmission. The ranges are delineated in Technical Reference TR-NPL-000335.

(D) Improved Return Loss

(1) On Effective Four-Wire Transmission at Four-Wire Point of Termination (applicable to each two-wire port): Provides for a fixed 600 ohm impedance, variable level range and simplex reversal. Telephone Company equipment is required at the customer's premises where this option is ordered. The Improved Return Loss parameters are delineated in Technical Reference TR-NPL-000335.

(2) On Effective Two-Wire Transmission at Two-Wire Point of Termination: Provides for more stringent Echo Control specifications. In order for this option to be applicable, the transmission path must be four-wire at one POT and two-wire at the other POT. Placement of Telephone Company equipment may be required at the customer's premises with the two-wire POT. The Improved Return Loss parameters are delineated in Technical Reference TR-NPL-000335.

(This page filed under Transmittal No. 1)

7. Special Access Service (Cont'd)7.7 Voice Grade Service (Cont'd)7.7.4 Optional Features and Functions (Cont'd)(E) Data Capability (D Conditioning)

Data Capability provides transmission characteristics suitable for data communications. Specifically, Data Capability provides for the control of Signal to C-Notched Noise Ratio and intermodulation distortion. It is available for two-point services or three-point multipoint services.

The Signal to C-Notched Noise Ratio and intermodulation distortion parameter for Data Capability are:

- Signal to C-Notched Noise Ratio is equal to or greater than 32dB
- Intermodulation distortion:
 - Signal to second order modulation products (R2) is equal to or greater than 38dB.
 - Signal to third order modulation products (R3) is equal to or greater than 42 dB

When a service equipped with Data Capability is used for voice communications, the quality of the voice transmission may not be satisfactory.

(F) Telephoto Capability

Telephoto Capability provides transmission characteristics suitable for telephotographic communications. Specifically, Telephoto Capability is provided for the control of attenuation distortion and envelope delay distortion on telephotographic services. The attenuation distortion and envelope delay distortion parameters for Telephoto Capability are:

(This page filed under Transmittal No. 1)

7. Special Access Service (Cont'd)

7.7 Voice Grade Service (Cont'd)

7.7.4 Optional Features and Functions (Cont'd)

(F) Telephoto Capability (Cont'd)

<u>Attenuation Distortion</u> (1004Hz Reference)		<u>Envelope Delay Distortion</u>	
<u>Frequency Range (Hz)</u>	<u>Variation (dB)</u>	<u>Frequency Range (Hz)</u>	<u>Variation (mcs)</u>
500-3000	-0.5 to +1.5	1000-2600	110
300-3200	-1.0 to +2.5	800-2800	180

(G) Signaling Capability

Signaling Capability provides for the ability to transmit signals from one customer premises to another customer premises on the same service.

(H)

(D)

(D)

(This page filed under Transmittal No. 237)

7. Special Access Service (Cont'd)

7.7 Voice Grade Service (Cont'd)

7.7.4 Optional Features and Functions (Cont'd)

(I) Four-Wire/Two-Wire Conversions

When a customer requests that an effective four-wire channel be terminated with a two-wire channel interface at the customer designated premises, a four-wire to two-wire conversion is required. The rate for the conversion is included as part of the basic Channel Termination rate.

(J) Improved Two-Wire Voice Transmission

(1) Loss Deviation

The maximum Loss Deviation of the 1004 HZ loss relative to the Expected measured Loss (EML) is -4.0 dB to +4.0 dB.

(2) Attenuation Distortion

The maximum Attenuation Distortion in the 404 to 280 Hz frequency band relative to loss at 1004 Hz is -2.0 dB to +6.0 dB.

(3) C-Message Noise

The maximum C-Message Noise for the transmission path at the route miles listed is less than:

<u>Route Miles</u>	<u>C-Message Noise</u>
less than 50	35 dBrnco
51 to 100	37 dBrnco
101 to 200	40 dBrnco
201 to 400	43 dBrnco
401 to 1000	45 dBrnco

(This page filed under Transmittal No. 1)

7. Special Access Service (Cont'd)7.7 Voice Grade Service (Cont'd)7.7.4 Optional Features and Functions (Cont'd)(J) Improved Two-Wire Voice Transmission (Cont'd)(4) Return Loss

The Return Loss, expressed as Echo Return Loss (ERL) and Singing Return Loss (SRL), is equal to or greater than:

ERL	13.0 dB
SRL	6.0 dB

The rate for the provision of Improved Two-Wire Voice Transmission is included as part of the basic Channel Termination rate.

(This page filed under Transmittal No. 1)

Issued: February 16, 2001

Effective: March 3, 2001

Four AT&T Plaza, Dallas, Texas 75202

7. Special Access Service (Cont'd)

7.7 Voice Grade Service (Cont'd)

7.7.4 Optional Features and Functions (Cont'd)

The following table shows the technical specifications packages with which the optional features and functions are available.

	Available with Technical Specifications Package VG-												
	C	1	2	3	4	5	6	7	8	9	10	11	W
C-Type Conditioning Central Office Bridging Capability	X					X	X	X	X	X	X		
Customer Specified Premises Receive Level			X	X				X	X	X			
Data Capability	X						X	X			X		
Improved Return Loss For Effective Four-Wire Transmission		X	X	X	X	X	X	X	X	X	X	X	X
For Effective Two-Wire Transmission	X		X	X				X					
Improved Two-Wire Voice Transmission													X
PPSN Interface Arrangement ⁽¹⁾	X									X			
Sealing Current Conditioning	X						X						
Signaling Capability	X	X	X	X				X	X	X			
Telephoto Capability	X											X	

(1) As of October 6, 2004, PPSN Interface Arrangement service utilizing the X.25 protocol and the X.75 protocol is obsolete and limited to existing installations, at existing locations, for existing customers.

(N)
 (N)
 (N)

(This page filed under Transmittal No. 72)

7. Special Access Service (Cont'd)7.7 Voice Grade Service (Cont'd)7.7.5 WATS Access Line (WAL) Service(A) Basic Channel Description

A WATS Access Line service provides a service for voice frequency transmission capability. The service provides a connection between a customer designated premises and a WATS serving office associated with the closed end of 800 Service or WATS. Originating access is provided with Feature Group D Switched Access Service as set forth in Section 6, preceding. Terminating access is provided with Feature Group A, B, or D as set forth in Section 6, preceding.

WAL Service can be arranged for screening, blocking and directionality at the option of the customer and where available. It is provided with either rotary dial or dual tone multifrequency address signaling and either loop start, ground start, E&M, or reverse battery supervisory signaling. The choice of the type of signaling is at the option of the customer and subject to the technical limitations identified in the Technical Reference TR-NPL-000334. WATS Access Line Service is provided as an effective two-wire, or an effective four-wire transmission path.

WAL Service is provided for interstate communications only. All originating intrastate intraLATA calls will be blocked.

(This page filed under Transmittal No. 253)

7. Special Access Service (Cont'd)

7.7 Voice Grade Service (Cont'd)

7.7.5 WATS Access Line (WAL) Service (Cont'd)

(A) Basic Channel Description (Cont'd)

The following diagram depicts a WATS Access Line service.

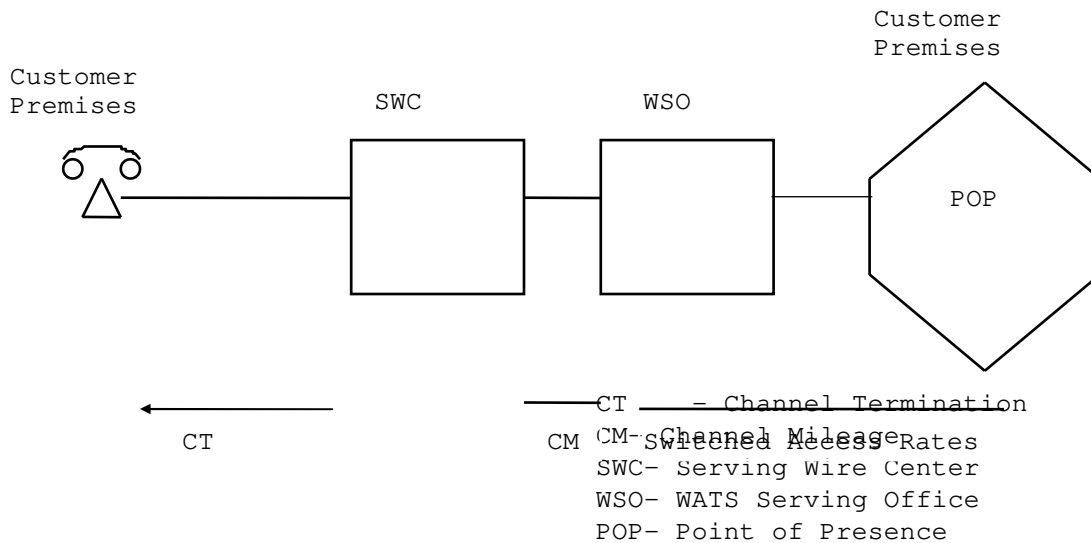

Applicable Rate elements are:

- CT - Channel Termination (1 applicable)
- CM - Channel Mileage
 - Optional Features and Functions when ordered (per channel termination).

(B) Technical Specifications

Technical specifications and examples of application are delineated in Technical Reference TR-NPL-000334.

(C) Channel Interfaces

Compatible channel interfaces are set forth in Technical Reference TR-NPL-000334.

(This page filed under Transmittal No. 1)

7. Special Access Service (Cont'd)

7.7 Voice Grade Service (Cont'd)

7.7.5 WATS Access Line (WAL) Service (Cont'd)

(D) Optional Features and Functions

- (1) Improved two-wire voice transmission specifications
- (2) Certain other options associated with WAL services are as either Line Termination or Common Switching optional features as defined in Section 6 preceding.
- (3) WATS Access Lines use the same Features and Functions as Voice Grade Service.

The following table shows the services with which the Optional Features and Functions are available.

	Available with Technical Specifications Package WALs-					
	<u>EA</u>	<u>EB</u>	<u>ED</u>	<u>EG</u>	<u>FA</u>	<u>FJ</u>
Effective 2-Wire	X				X	X
Effective 4-Wire		X		X		
Improved 2-Wire Voice Transmission				X	X	
Improved Return Loss 2-Wire						X
Digital DS1			X			
Bridging Capability	X	X		X	X	X

(This page filed under Transmittal No. 1)

7. Special Access Service (Cont'd)

7.7 Voice Grade Service⁽³⁾ (Cont'd)

7.7.6 Rates and Charges

Effective November 1, 2017, all rate elements, other than End User channel terminations and their applicable optional features⁽²⁾ in Non-Competitive Counties, are no longer available from Section 7.7.6 for new service subscriptions.⁽¹⁾ The application of rates and charges for Special Access services is based upon the county classification as Competitive or Non-Competitive, as provided in Section 7.2.2. A list of Competitive and Non-Competitive Counties is located in Sections 17.2(C) and (D).

	<u>USOC</u>	<u>Monthly Rate</u>	<u>Non-Recurring Charge</u>
(A) <u>Channel Termination</u>			
- Per Termination			
- Two-Wire	T6E2X	\$24.03 (I)	\$200.00
- Four-Wire	T6E4X	\$24.03 (I)	\$200.00
- WATS Access Line			
- Per point of termination			
- Two-Wire with screening and blocking	X2W	\$24.03 (I)	\$200.00
- Four-Wire with screening and blocking	X4W	\$24.03 (I)	\$200.00
(B) <u>Channel Mileage</u>		<u>USOC</u>	<u>Monthly Rate</u>
(1) Channel Mileage Facility			
- Per Mile		1L5XX/CMF	\$0.44
(2) Channel Mileage Termination			
- Per Termination		1L5XX/CMT	\$8.90

⁽¹⁾ Until February 1, 2018, End User channel terminations and their applicable optional features that had not qualified for Phase II, Level 2 pricing flexibility prior to June 1, 2017, will be rated at the price cap rate regardless of the status of the county in which the applicable wire center is located.

⁽²⁾ Optional features for End User channel terminations includes all optional features in Section 7, except for the Transfer Arrangement.

⁽³⁾ Effective November 20, 2019, this Service will no longer be available for purchase by new or existing customers, and service agreements may no longer be renewed. In addition, requests to move, add or change existing service arrangements will not be accepted. Following the expiration of a customer's existing term agreement, service will be provided on a month-to-month basis at the applicable monthly extension rates until the service is discontinued. AT&T currently plans to discontinue this Service on or after June 30, 2024.

(This page filed under Transmittal No. 340)

7. Special Access Service (Cont'd)

7.7 Voice Grade Service⁽¹⁾ (Cont'd) (N)

7.7.6 Rates and Charges (Cont'd)

(C) Optional Features and Functions

(1) Bridging

(a) Voice Bridging

	<u>USOC</u>	<u>Monthly</u>
	<u>Rate</u>	
Two-Wire/Four Wire		
- Per port		
- Two-Wire	BCNV2	\$2.72
- Four-Wire	BCNV4	\$3.42

(b) Data Bridging

Two-Wire/Four-Wire		
- Per Port		
- Two-Wire	BCND2	\$2.72
- Four-Wire	BCND4	\$3.42

(1) Effective November 20, 2019, this Service will no longer be available for purchase by new or existing customers, and service agreements may no longer be renewed. In addition, requests to move, add or change existing service arrangements will not be accepted. Following the expiration of a customer's existing term agreement, service will be provided on a month-to-month basis at the applicable monthly extension rates until the service is discontinued. AT&T currently plans to discontinue this Service on or after June 30, 2024. (N)

(This page filed under Transmittal No. 318)

7. Special Access Service (Cont'd)

7.7 Voice Grade Service⁽¹⁾ (Cont'd)

(N)

7.7.6 Rates and Charges (Cont'd)

(C) Optional Features and Functions (Cont'd)

	<u>USOC</u>	<u>Monthly Rate</u>	<u>Non- recurring Charges</u>
(2) Conditioning			
- Per Termination			
- C-Type	X1CPT	\$ 3.79	None
- Improved Attenuation Distortion*	UHW	5.37	\$180.80
- Improved Envelope Delay Distortion*	UHY	26.83	287.06
- Sealing Current	1HBPT	6.97	None

* Improved Attenuation Distortion and Improved Envelope Delay Distortion will continue to be provided to all customers who were provided with either or both of these optional features in conjunction with C-Type Conditioning prior to September 29, 1988.

⁽¹⁾ Effective November 20, 2019, this Service will no longer be available for purchase by new or existing customers, and service agreements may no longer be renewed. In addition, requests to move, add or change existing service arrangements will not be accepted. Following the expiration of a customer's existing term agreement, service will be provided on a month-to-month basis at the applicable monthly extension rates until the service is discontinued. AT&T currently plans to discontinue this Service on or after June 30, 2024.

(N)
 |
 (N)

(This page filed under Transmittal No. 318)

7. Special Access Service (Cont'd)

7.7 Voice Grade Service⁽¹⁾ (Cont'd)

(N)

7.7.6 Rates and Charges (Cont'd)

(C) Optional Features and Functions (Cont'd)

	<u>USOC</u>	<u>Monthly Rate</u>	<u>Non- recurring Charges</u>
(3) Improved Return Loss for Effective Two-Wire or Four-Wire Transmission			
- Per termination			
- Two-Wire	1RL2W	\$ 8.24	None
- Four-Wire	1RL4W	8.20	None
(4) Customer Specified Received Level -Per two-wire termination	RLS	4.61	None
(5) Data Capability - Per termination	XDCPT	5.67	\$ 91.27
(6) Telephoto Capability - Per termination	XTCPT	7.40	\$377.67

(1) Effective November 20, 2019, this Service will no longer be available for purchase by new or existing customers, and service agreements may no longer be renewed. In addition, requests to move, add or change existing service arrangements will not be accepted. Following the expiration of a customer's existing term agreement, service will be provided on a month-to-month basis at the applicable monthly extension rates until the service is discontinued. AT&T currently plans to discontinue this Service on or after June 30, 2024.

(N)
 |
 (N)

(This page filed under Transmittal No. 318)

7. Special Access Service (Cont'd)

7.7 Voice Grade Service⁽¹⁾ (Cont'd)

(N)

7.7.6 Rates and Charges (Cont'd)

(C) Optional Features and Functions (Cont'd)

	<u>USOC</u>	<u>Monthly Rate</u>
(7) Signaling Capability - Per termination	XSS++	\$ 9.94

In lieu of ++, substitute appropriate two-digit code from the following list to specify type of signaling.

- AB
- AC
- CT
- DX
- DY
- EA
- EB
- EC
- EX
- GO
- GS
- LA
- LB
- LC
- LO
- LR
- LS
- RV
- SF

⁽¹⁾ Effective November 20, 2019, this Service will no longer be available for purchase by new or existing customers, and service agreements may no longer be renewed. In addition, requests to move, add or change existing service arrangements will not be accepted. Following the expiration of a customer's existing term agreement, service will be provided on a month-to-month basis at the applicable monthly extension rates until the service is discontinued. AT&T currently plans to discontinue this Service on or after June 30, 2024.

(N)
 |
 (N)

(This page filed under Transmittal No. 318)

7. Special Access Service (Cont'd)

7.7 Voice Grade Service (Cont'd)

7.7.6 Rates and Charges (Cont'd)

(C) Optional Features and Functions (Cont'd)

Monthly
Rate

(8)

(D)

(D)

(This page filed under Transmittal No. 237)

Issued: September 12, 2012

Effective: September 27, 2012

Four AT&T Plaza, Dallas, Texas 75202

ACCESS SERVICE

7. Special Access Service (Cont'd)

7.8 Program Audio Service^{(1) (2)} (N)

7.8.1 Basic Channel Description

A Program Audio channel is a channel with bandwidth measured in Hz for the transmission of a complex signal voltage. The actual bandwidth is a function of the channel interface selected by the customer. Only one-way transmission is provided. Program Audio channels are provided between customer designated premises or between a customer designated premises and a Telephone Company hub or hubs.

7.8.2 Technical Specifications Packages

<u>Parameter</u>	<u>C*</u>	<u>Package AP-</u>			
		<u>1</u>	<u>2</u>	<u>3</u>	<u>4</u>
Actual Measured Loss	X	X	X	X	X
Amplitude Tracking	X				
Crosstalk	X	X	X	X	X
Distortion Tracking	X				
Gain/Frequency					
Distortion	X	X	X	X	X
Group Delay	X				
Noise	X	X	X	X	X
Phase Tracking	X				
Short-Term Gain					
Stability	X				
Short-Term Loss	X				
Total Distortion	X	X	X	X	X

The technical specifications are delineated in Technical Reference TR-NPL-000337.

7.8.3 Channel Interfaces

The following channel interfaces (CIs) define the bandwidths that are available for a Program Audio channel:

* The desired parameters are selected by the customer from the list of available parameters.

(1) Effective November 20, 2019, this Service will no longer be available for purchase by new or existing customers, and service agreements may no longer be renewed. In addition, requests to move, add or change existing service arrangements will not be accepted. Following the expiration of a customer's existing term agreement, service will be provided on a month-to-month basis at the applicable monthly extension rates until the service is discontinued. AT&T currently plans to discontinue this Service on or after November 1, 2020.

(2) Program Audio is discontinued and no longer available in this publication (see WC Dkt. 19-238). (N)

(This page filed under Transmittal No. 337)

7. Special Access Service (Cont'd)

7.8 Program Audio Service^{(1) (2)} (Cont'd)

(N)

7.8.3 Channel Interfaces (Cont'd)

<u>CI</u>	<u>Bandwidth</u>
PG-1	Nominal frequency from 50 to 15000 Hz
PG-3	Nominal frequency from 200 to 3500 Hz
PG-5	Nominal frequency from 100 to 5000 Hz
PG-8	Nominal frequency from 50 to 8000 Hz

Compatible channel interfaces are set forth in 15.3 following.

7.8.4 Optional Features and Functions

(A) Gain Conditioning

Control of 1004 Hz AML at initiation of service to 0dB ± 0.5 dB.

The following table shows the technical specifications packages with which the optional features and functions are available.

	<u>Available with Technical Specifications Package AP-</u>				
	<u>C</u>	<u>1</u>	<u>2</u>	<u>3</u>	<u>4</u>
Gain Conditioning	X	X	X	X	X

(1) Effective November 20, 2019, this Service will no longer be available for purchase by new or existing customers, and service agreements may no longer be renewed. In addition, requests to move, add or change existing service arrangements will not be accepted. Following the expiration of a customer's existing term agreement, service will be provided on a month-to-month basis at the applicable monthly extension rates until the service is discontinued. AT&T currently plans to discontinue this Service on or after November 1, 2020.

(2) Program Audio is discontinued and no longer available in this publication (see WC Dkt. 19-238).

(N)
(N)

(This page filed under Transmittal No. 337)

7. Special Access Service (Cont'd)
 7.8 Program Audio Service^{(3) (4)}

(N)

7.8.5 Rates and Charges

Effective November 1, 2017, all rate elements, other than End User channel terminations and their applicable optional features⁽²⁾ in Non-Competitive Counties, are no longer available from Section 7.8.5 for new service subscriptions.⁽¹⁾ The application of rates and charges for Special Access services is based upon the county classification as Competitive or Non-Competitive, as provided in Section 7.2.2. A list of Competitive and Non-Competitive Counties is located in Sections 17.2(C) and (D).

		Monthly	Daily*	Nonrecurring	
	USOC	Rate	Rate	Charge	
				Monthly	Daily
<u>(A) Channel Termination</u>					
- Per Termination					
- 200 to 3500 Hz	T6ECS	\$25.00	\$4.00	\$289.75	\$289.75
- 100 to 5000 Hz	T6ECS	28.00	4.00	289.75	289.75
- 50 to 8000 Hz	T6ECS	30.00	4.00	289.75	289.75
- 50 to 15000 Hz	T6ECS	110.00	12.00	289.75	289.75
<u>(B) Channel Mileage</u>					
<u>(1) Channel Mileage Facility</u>					
- Per Mile					
- 200 to 3500 Hz		1L5XX/CMF	\$2.00	\$2.00	
- 100 to 5000 Hz		1L5XX/CMF	\$2.00	\$2.00	
- 50 to 8000 Hz		1L5XX/CMF	\$2.00	\$2.00	
- 50 to 15000 Hz		1L5XX/CMF	\$3.00	\$2.00	
<u>(2) Channel Mileage Termination</u>					
- Per Termination					
- 200 to 3500 Hz		1L5XX/CMT	\$15.50	\$2.00	
- 100 to 5000 Hz		1L5XX/CMT	\$15.50	\$2.00	
- 50 to 8000 Hz		1L5XX/CMT	\$20.00	\$2.00	
- 50 to 15000 Hz		1L5XX/CMT	\$32.00	\$3.35	

* Daily rates will be topped and maximum rates derived as set forth in 7.2.2.(B) preceding.

- (1) Until February 1, 2018, End User channel terminations and their applicable optional features that had not qualified for Phase II, Level 2 pricing flexibility prior to June 1, 2017, will be rated at the price cap rate regardless of the status of the county in which the applicable wire center is located.
- (2) Optional features for End User channel terminations includes all optional features in Section 7, except for the Transfer Arrangement.
- (3) Effective November 20, 2019, this Service will no longer be available for purchase by new or existing customers, and service agreements may no longer be renewed. In addition, requests to move, add or change existing service arrangements will not be accepted. Following the expiration of a customer's existing term agreement, service will be provided on a month-to-month basis at the applicable monthly extension rates until the service is discontinued. AT&T currently plans to discontinue this Service on or after November 1, 2020.
- (4) Program Audio is discontinued and no longer available in this publication (see WC Dkt. 19-238).

(N)
 (N)

(This page filed under Transmittal No. 337)

7. Special Access Service (Cont'd)

7.8 Program Audio Service^{(1) (2)}

(N)

7.8.5 Rates and Charges (Cont'd)

(C) Optional Features and Functions

	USOC	Monthly Rate	Daily* Rate	Nonrecurring Charge	
				Monthly	Daily
(1) Gain Conditioning	XGC	\$2.00 (I)	\$2.00 (I)	\$73.25	\$73.25

* Daily rates will be topped and maximum rates derived as set forth in 7.2.2.(B) preceding.

(1) Effective November 20, 2019, this Service will no longer be available for purchase by new or existing customers, and service agreements may no longer be renewed. In addition, requests to move, add or change existing service arrangements will not be accepted. Following the expiration of a customer's existing term agreement, service will be provided on a month-to-month basis at the applicable monthly extension rates until the service is discontinued. AT&T currently plans to discontinue this Service on or after November 1, 2020.

(2) Program Audio is discontinued and no longer available in this publication (see WC Dkt. 19-238).

(N)
(N)

(This page filed under Transmittal No. 337)

Issued: December 16, 2022

Effective: January 1, 2023

Four AT&T Plaza, Dallas, Texas 75202

ACCESS SERVICE

7. Special Access Service (Cont'd)7.9 Video Service7.9.1 Basic Channel Description

A Video channel is a channel with one-way transmission capability for a standard 525 line/60 field monochrome, or National Television Systems Committee color, video signal and one or more audio signals, as described below. The provision and the bandwidth of the associated audio signal(s) is a function of the channel interface selected by the customer. Video channels are provided between customer designated premises or between a customer designated premises and a Telephone Company hub or hubs, where available.

(A) Analog Video Service⁽²⁾

(N)

The bandwidth for analog video service⁽²⁾ is either 30 Hz to 4.5 MHz or 30 Hz to 6.6 MHz. The associated audio signal(s) may be either duplexed or provided as one to four separate channels.

(N)

(1)

⁽¹⁾ Material in this Section has been de-tariffed as required by the Commission upon use of the forbearance relief pursuant to FCC Memorandum Opinion and Order No. 07-180, released October 12, 2007. Terms and Conditions associated with de-tariffed services are available at www.att.com/guidebook.

⁽²⁾ Effective December 31, 2020, Broadcast Video (TV1) service will no longer be available for purchase by new or existing customers, and service agreements may no longer be renewed. In addition, requests to move, add, or change existing service arrangements will not be accepted. Following the expiration of a customer's existing term agreement, service will be provided on a month-to-month basis at the applicable Monthly rate until the service is discontinued. AT&T currently plans to discontinue this Service on or after December 31, 2021.

(N)

(N)

(This page filed under Transmittal No. FC-20-0006)

Issued: December 16, 2020

Effective: December 31, 2020

Four AT&T Plaza, Dallas, Texas 75202

ACCESS SERVICE

7. Special Access Service (Cont'd)

7.9 Video Service (Cont'd)

7.9.1 Basic Channel Description (Cont'd)

(1)

(D)

⁽¹⁾ See footnote (1) on page 7-66.

(This page filed under Transmittal No. 176)

Effective: February 8, 2008

Four AT&T Plaza, Dallas, Texas 75202

ACCESS SERVICE

7. Special Access Service (Cont'd)

7.9 Video Service (Cont'd)

7.9.2 Technical Specifications Packages

	<u>Package TV-</u>			(T)
<u>Parameter</u>	<u>C*</u>	<u>1</u>	<u>2</u>	(M)
Amplitude/Frequency Response Characteristics	X	X	X	
Audio-To-Video Time Differential	X	X	X	
Chrominance/Luminance Inequalities				
Gain	X	X	X	
Delay	X	X	X	
Chrominance/Luminance Intermodulation	X	X	X	
Chrominance Nonlinear Gain Distortion	X	X	X	
Chrominance Nonlinear Phase Distortion	X	X	X	
Crosstalk	X	X	X	
Differential Gain	X	X	X	
Differential Phase	X	X	X	
Dynamic Gain (picture and sync signal)	X	X	X	
Field-Time Distortion	X	X	X	
Gain/Difference Between Channels	X	X		
Phase Difference Between Channels	X	X		
Insertion Gain	X	X	X	
Line-Time Distortion	X	X	X	(M)
Luminance Non-Linear Distortion	X	X	X	
Maximum Steady-State Test Levels	X	X	X	
Short-Time Distortion	X	X	X	
Total Harmonic Distortion and Noise	X	X	X	
Transient Sync Signal				
Non-Linearity	X	X	X	

The technical specifications are delineated in Technical Reference TR-NPL-000338.

* The desired parameters are selected by the customer from the list of available parameters.
 Material now appearing on this page previously appeared on Original Page 7-66.

(This page filed under Transmittal No. 167)

7. Special Access Service (Cont'd)7.9 Video Service (Cont'd)7.9.3 Channel Interfaces

The following channel interfaces (CIs) define the bandwidth and the provision of the audio signal(s) associated with a Video Channel:

<u>CI</u>	<u>Audio Bandwidth</u>	<u>Provision</u>
2TV6-1	15kHz	1 Channel, diplexed
2TV6-2	15kHz	2 Channels, diplexed
2TV7-1	15kHz	1 Channel, diplexed
2TV7-2	15kHz	2 Channels, diplexed
4TV6-5	5kHz	1 Channel, separate
4TV6-15	15kHz	1 Channel, separate
4TV7-5	5kHz	1 Channel, separate
4TV7-15	15kHz	1 Channel, separate
6TV6-5	5kHz	2 Channels, separate
6TV6-15	15kHz	2 Channels, separate
6TV7-5	5kHz	2 Channels, separate
6TV7-15	15kHz	2 Channels, separate

Compatible channel interfaces are set forth in 15.3 following.

(This page filed under Transmittal No. 1)

ACCESS SERVICE

7. Special Access Service (Cont'd)

7.9 Video Service (Cont'd)

7.9.4 Rates and Charges

Effective November 1, 2017, all rate elements, other than End User channel terminations and their applicable optional features⁽²⁾ in Non-Competitive Counties, are no longer available from Section 7.9.4 for new service subscriptions.⁽¹⁾ The application of rates and charges for Special Access services is based upon the county classification as Competitive or Non-Competitive, as provided in Section 7.2.2. A list of Competitive and Non-Competitive Counties is located in Sections 17.2(C) and (D).

	USOC	Monthly Rate	Daily* Rate	Nonrecurring Charge		
				Monthly	Daily	
(A) Channel Termination						
(1) Analog						
- Per Termination						
- TV-1 ⁽³⁾ or 2	TMEV1	\$450.00	\$125.00	\$250.00	\$250.00	(N)
- 4TV-5	TMEV4	\$500.00	\$125.00	\$250.00	\$250.00	
- 6TV-5	TMEV6	\$500.00	\$125.00	\$250.00	\$250.00	
- TV-15	TMEV5	\$500.00	\$125.00	\$250.00	\$250.00	
(B) Channel Mileage						
(1) Channel Mileage Facility						
- Per Mile						
- TV 1 ⁽³⁾ or 2	1L5XX/CMF			\$60.00	\$35.00	(N)
- 4TV-5	1L5XX/CMF			\$60.00	\$35.00	
- 6TV-5	1L5XX/CMF			\$60.00	\$35.00	
- TV-15	1L5XX/CMF			\$60.00	\$35.00	
(2) Channel Mileage Termination						
- Per Termination						
- TV-1 ⁽³⁾ or 2	1L5XX/CMT			None	None	(N)
- 4TV-5	1L5XX/CMT			None	None	
- 6TV-5	1L5XX/CMT			None	None	
- TV-15	1L5XX/CMT			None	None	

* Daily rates will be topped and maximum rates derived as set forth in 7.2.2.(B) preceding.

⁽¹⁾ Until February 1, 2018, End User channel terminations and their applicable optional features that had not qualified for Phase II, Level 2 pricing flexibility prior to June 1, 2017, will be rated at the price cap rate regardless of the status of the county in which the applicable wire center is located.

⁽²⁾ Optional features for End User channel terminations includes all optional features in Section 7, except for the Transfer Arrangement.

⁽³⁾ Effective December 31, 2020, Broadcast Video (TV1) service will no longer be available for purchase by new or existing customers, and service agreements may no longer be renewed. In addition, requests to move, add, or change existing service arrangements will not be accepted. Following the expiration of a customer's existing term agreement, service will be provided on a month-to-month basis at the applicable Monthly rate until the service is discontinued. AT&T currently plans to discontinue this Service on or after December 31, 2021. (N)

(This page filed under Transmittal No. FC-20-0006)

ACCESS SERVICE

7. Special Access Service (Cont'd)

7.9 Video Service (Cont'd)

7.9.4 Rates and Charges (Cont'd)

(1)

(D)

⁽¹⁾ See footnote (1) on page 7-66.

(This page filed under Transmittal No. 176)

Issued: January 24, 2008

Effective: February 8, 2008

Four AT&T Plaza, Dallas, Texas 75202

ACCESS SERVICE

7. Special Access Service (Cont'd)

7.9 Video Service (Cont'd)

7.9.4 Rates and Charges (Cont'd)

(1)

(D)

⁽¹⁾ See footnote (1) on page 7-66.

(This page filed under Transmittal No. 176)

Issued: January 24, 2008

Effective: February 8, 2008

Four AT&T Plaza, Dallas, Texas 75202

7. Special Access Service (Cont'd)7.10 Digital Data Service⁽¹⁾

(N)

7.10.1 Basic Channel Description

A Digital Data channel is a channel for duplex four-wire transmission of synchronous serial data at the rate of 2.4, 4.8, 9.6, 56 or 64 kbps.* The actual bit rate is a function of the channel interface selected by the customer. The channel provides a synchronous service with timing provided by the Telephone Company through the Telephone Company's facilities to the customer in the received bit stream. Digital Data channels are only available via Telephone Company designated hubs and are provided between customer designated premises or between a customer designated premises and a Telephone Company hub or hubs. Digital Data service may also be ordered in conjunction with High Capacity (DS-1) to Analog/Digital (DS-0) multiplexing as set forth in 7.11.4 (5) following, and not be required to route through a Digital Data Service Hub as set forth in Technical Reference Pub L-780077-PB/NB.

The customer will provide the Channel Service Unit-type equipment or other Network Channel Terminating Equipment associated with the Digital Data channel at the customer premises. The interim program for interconnection of such equipment is set forth in Technical Reference PUB AS No. 1.

* 64kbps Service is only available with High Capacity Multiplexing DS1 to Voice/Digital as set forth in 7.11.4 (B)(5) following. 64kbps service is only available where technically feasible.

⁽¹⁾ Effective November 20, 2019, this Service will no longer be available for purchase by new or existing customers, and service agreements may no longer be renewed. In addition, requests to move, add or change existing service arrangements will not be accepted. Following the expiration of a customer's existing term agreement, service will be provided on a month-to-month basis at the applicable monthly extension rates until the service is discontinued. AT&T currently plans to discontinue this Service on or after June 30, 2024.

(N)

(N)

(This page filed under Transmittal No. 318)

7. Special Access Service (Cont'd)

7.10 Digital Data Service⁽¹⁾ (Cont'd)

(N)

7.10.2 Technical Specifications Packages

<u>Parameter</u>	<u>Package D-</u>			
	<u>1</u>	<u>2</u>	<u>3</u>	<u>4</u>
Error-Free Seconds	X	X	X	X

The Telephone Company will provide a channel capable of meeting a monthly average performance equal to or greater than 99.875% error-free seconds (if provided through a Digital Data hub) while the channel is in service, if it is measured through a CSU equivalent which is designed, manufactured, and maintained to conform with the specifications contained in Technical Reference PUB 62310.

Voltages which are compatible with Digital Data Service are delineated in Technical Reference TR-NPL-000341.

⁽¹⁾ Effective November 20, 2019, this Service will no longer be available for purchase by new or existing customers, and service agreements may no longer be renewed. In addition, requests to move, add or change existing service arrangements will not be accepted. Following the expiration of a customer's existing term agreement, service will be provided on a month-to-month basis at the applicable monthly extension rates until the service is discontinued. AT&T currently plans to discontinue this Service on or after June 30, 2024.

(N)
 |
 (N)

(This page filed under Transmittal No. 318)

7. Special Access Service (Cont'd)

7.10 Digital Data Service⁽¹⁾ (Cont'd)

(N)

7.10.3 Channel Interfaces

The following channel interfaces (CIs) define the bit rates that are available for a Digital Data channel:

<u>CI</u>	<u>Bit Rate</u>
DU-24	2.4 kbps
DU-48	4.8 kbps
DU-96	9.6 kbps
DU-56	56.0 kbps
DU-56A	64.0 kbps

Compatible channel interfaces are set forth in 15.3 following.

7.10.4 Optional Features and Functions

(A) Central Office Bridging Capability

The following table shows the technical specifications packages with which the optional features and functions are available.

	<u>Available with Technical Specifications Package D-</u>			
	<u>1</u>	<u>2</u>	<u>3</u>	<u>4</u>
Central Office Bridging Capability	X	X	X	X

⁽¹⁾ Effective November 20, 2019, this Service will no longer be available for purchase by new or existing customers, and service agreements may no longer be renewed. In addition, requests to move, add or change existing service arrangements will not be accepted. Following the expiration of a customer's existing term agreement, service will be provided on a month-to-month basis at the applicable monthly extension rates until the service is discontinued. AT&T currently plans to discontinue this Service on or after June 30, 2024.

(N)

(N)

(This page filed under Transmittal No. 318)

7. Special Access Service (Cont'd)

7.10 Digital Data Service⁽³⁾ (Cont'd)

7.10.5 Rates and Charges

Effective November 1, 2017, all rate elements, other than End User channel terminations and their applicable optional features⁽²⁾ in Non-Competitive Counties, are no longer available from Section 7.10.5 for new service subscriptions.⁽¹⁾ The application of rates and charges for Special Access services is based upon the county classification as Competitive or Non-Competitive, as provided in Section 7.2.2. A list of Competitive and Non-Competitive Counties is located in Sections 17.2(C) and (D).

	USOC	Monthly Rate	Nonrecurring Rates
- Per termination			
- 2.4 kbps	T6ECS	\$ 78.92 (I)	\$250.00
- 4.8 kbps	T6ECS	78.92 (I)	250.00
- 9.6 kbps	T6ECS	78.92 (I)	250.00
-56.0 kbps	T6ECS	78.92 (I)	250.00
-64.0 kbps	T6ECS	78.92 (I)	250.00

(B) Channel Mileage

	USOC	Monthly Rates
(1) Channel Mileage Facility		
- Per Mile		
- 2.4 kbps	1L5XX/CMF	\$0.72
- 4.8 kbps	1L5XX/CMF	0.72
- 9.6 kbps	1L5XX/CMF	0.72
- 56 kbps	1L5XX/CMF	0.72
- 64 kbps	1L5XX/CMF	0.72
(2) Channel Mileage Termination		
- Per Termination		
- 2.4 kbps	1L5XX/CMT	\$13.00
- 4.8 kbps	1L5XX/CMT	13.00
- 9.6 kbps	1L5XX/CMT	13.00
- 56 kbps	1L5XX/CMT	13.00
- 64 kbps	1L5XX/CMT	13.00

⁽¹⁾ Until February 1, 2018, End User channel terminations and their applicable optional features that had not qualified for Phase II, Level 2 pricing flexibility prior to June 1, 2017, will be rated at the price cap rate regardless of the status of the county in which the applicable wire center is located.

⁽²⁾ Optional features for End User channel terminations includes all optional features in Section 7, except for the Transfer Arrangement.

⁽³⁾ Effective November 20, 2019, this Service will no longer be available for purchase by new or existing customers, and service agreements may no longer be renewed. In addition, requests to move, add or change existing service arrangements will not be accepted. Following the expiration of a customer's existing term agreement, service will be provided on a month-to-month basis at the applicable monthly extension rates until the service is discontinued. AT&T currently plans to discontinue this Service on or after June 30, 2024.

(This page filed under Transmittal No. 340)

7. Special Access Service (Cont'd)

7.10 Digital Data Service⁽¹⁾ (Cont'd)

(N)

7.10.5 Rates and Charges (Cont'd)

<u>(C) Optional Features and Functions</u>	<u>USOC</u>	<u>Monthly Rate</u>
(1) Bridging - Per port	BCNDA	\$16.51

⁽¹⁾ Effective November 20, 2019, this Service will no longer be available for purchase by new or existing customers, and service agreements may no longer be renewed. In addition, requests to move, add or change existing service arrangements will not be accepted. Following the expiration of a customer's existing term agreement, service will be provided on a month-to-month basis at the applicable monthly extension rates until the service is discontinued. AT&T currently plans to discontinue this Service on or after June 30, 2024.

(N)
 |
 (N)

(This page filed under Transmittal No. 318)

7. Special Access Service (Cont'd)

7.11 High Capacity Service

7.11.1 Basic Channel Description

A High Capacity channel is a channel for the transmission of nominal 1.544, 3.152, 6.312, 44.736 (DS3), or 274.176 Mbps isochronous serial data. The actual bit rate and framing format is a function of the channel interface selected by the customer. DS3 will be provided with an electrical handoff at the customer premise at the request of the customer. High Capacity channels are provided between customer designated premises or between a customer designated premises and a Telephone Company hub or hubs.

The customer will provide the Network Channel Terminating Equipment associated with the High Capacity channel at the customer's premises. The interim program for interconnection of such equipment is set forth in Technical Reference PUB AS No. 1.

(T)

DS3 High Capacity service offerings are only available where facilities and operating conditions permit. Where facilities and/or operating conditions do not permit, Special Construction as set forth in Pacific Bell Telephone Company's FCC No. 2 shall apply.

7.11.2 Technical Specifications Packages

<u>Parameters</u>	<u>Package HC-</u>					
	<u>0</u>	<u>1</u>	<u>1C</u>	<u>2</u>	<u>3</u>	<u>4</u>
Error-Free Seconds		X				

(T)

A channel with technical specifications package HC1 will be capable of an error-free second performance of 98.75% over a continuous 24 hour period as measured at the 1.544 Mbps rate through a CSU equivalent which is designed, manufactured, and maintained to conform with the specifications contained in Technical Reference PUB 62411 and Technical Advisory TA-TSY-000342.

(This page filed under Transmittal No. 4)

7. Special Access Service (Cont'd)7.11 High Capacity Service (Cont'd)7.11.3 Channel Interfaces

The following channel interfaces (CIs) define the bit rates that are available for a High Capacity channel:

<u>CI</u>	<u>Bit Rate</u>
DS-15	1.544 Mbps (DS1)
DS-27	274.176 Mbps (DS4)
DS-31	3.152 Mbps (DS1C)
DS-44	44.736 Mbps (DS3)
DS-63	6.312 Mbps (DS2)

Compatible channel interfaces are set forth in 15.3 following.

7.11.4 Optional Features and Functions(A) Transfer Arrangement

An arrangement that affords the customer an additional measure of flexibility in the use of their access channel(s). The arrangement can be utilized to transfer a leg of a Special Access Service to either a spare or working channel that terminates in either the same or a different customer designated premises. A dial-up control service is required to operate the transfer arrangement. A spare channel, if required, is not included as part of the option.

(This page filed under Transmittal No. 1)

7. Special Access Service (Cont'd)7.11 High Capacity Service (Cont'd)7.11.4 Optional Features and Functions(B) Central Office Multiplexing(1) DS4 to DS1

An arrangement that converts a 274.176 Mbps channel to 168 DS1 channels using digital time division multiplexing.

(2) DS3 to DS1

An arrangement that converts a 44.736 Mbps channel to 28 DS1 channels using digital time division multiplexing.

(3) DS2 to DS1

An arrangement that converts a 6.312 Mbps channel to four DS1 channels using digital time division multiplexing.

(4) DS1C to DS1

An arrangement that converts a 3.152 Mbps channel to two DS1 channels using digital time division multiplexing.

(5) DS1 to Voice/Digital⁽¹⁾

(N)

An arrangement that converts a 1.544 Mbps channel to 24 channels for use with Voice Grade or Digital Data Services.

⁽¹⁾ Effective November 20, 2019, this Service will no longer be available for purchase by new or existing customers, and service agreements may no longer be renewed. In addition, requests to move, add or change existing service arrangements will not be accepted. Following the expiration of a customer's existing term agreement, service will be provided on a month-to-month basis at the applicable monthly extension rates until the service is discontinued. AT&T currently plans to discontinue this Service on or after June 30, 2024.

(N)

(N)

(This page filed under Transmittal No. 318)

7. Special Access Service (Cont'd)

7.11 High Capacity Service (Cont'd)

7.11.4 Optional Features and Functions (Cont'd)

(B) Central Office Multiplexing (Cont'd)

(6) DS1 to DS0⁽¹⁾ (N)
 An arrangement that converts a 1.544 Mbps channel to 23 64.0 Kbps channels utilizing digital time division multiplexing.

(7) DS0 to Subrate⁽¹⁾ (N)
 An arrangement that converts a 64.0 Kbps channel to subspeeds of up to twenty 2.4 Kbps, ten 4.8 Kbps, or five 9.6 Kbps channels using digital time division multiplexing.

The following table shows the technical specifications packages with which the optional features and functions are available.

Available with Technical Specifications Package HC-
0 1 1C 2 3 4

Central Office Multiplexing:						
DS4 to DS1						X
DS3 to DS1					X	
DS2 to DS1				X		
DS1C to DS1			X			
DS1 to Voice/Digital ⁽¹⁾	X					
DS1 to DS0 ⁽¹⁾		X				
DS0 to Subrate* ⁽¹⁾	X					
Cross-Connect		X				
Transfer Arrangement		X				

(8) Multiplexer Cross-Connect (MCC)
 An arrangement which provides the cross-connect of one channel of a Special Access High Capacity DS3 multiplexer to a channel of another Special Access High Capacity DS3 Multiplexer.

Multiplexer Cross-Connection (MCC) will be charged per cross-connect per central office, where the cross-connection is performed. If MCC is provided between two Telephone Company

* Available only on a channel of 1.544 Mbps facility to a Telephone Company DDS hub.

⁽¹⁾ Effective November 20, 2019, this Service will no longer be available for purchase by new or existing customers, and service agreements may no longer be renewed. In addition, requests to move, add or change existing service arrangements will not be accepted. Following the expiration of a customer's existing term agreement, service will be provided on a month-to-month basis at the applicable monthly extension rates until the service is discontinued. AT&T currently plans to discontinue this Service on or after June 30, 2024. (N)

(This page filed under Transmittal No. 318)

7. Special Access Service (Cont'd)

7.11 High Capacity Service (Cont'd)

7.11.4 Optional Features and Functions (Cont'd)

(B) Central Office Multiplexing (Cont'd)

(8) Multiplexer Cross-Connect (MCC) (Cont'd)

offices where DS3 multiplexing is performed, appropriate Channel Mileage and Channel Mileage Termination Charges for the lower speed DS1 service will apply between the two central offices along with one MCC charge per cross-connect per central office.

When one service is cross-connected to another service, the two cross-connected services are treated separately for service performance measurement and service interruption credit purposes.

If two customers are involved, one customer will be responsible for the entire billing of MCC.

(N)

(N)

(This page filed under Transmittal No. 17)

7. Special Access Service (Cont'd)

7.11 High Capacity Service (Cont'd)

7.11.5 Rates and Charges General Description

This section contains the specific regulations governing the rates and charges which apply to High Capacity Services.

DS3 High Capacity Service is available under a month-to-month*, one, three or five-year billing period as described in 7.11.5.1 (A), following.^{(1) (2) (3)} If the Utility initiates rate changes resulting in a decrease of rates for an existing DS3 service with a 1, 3 or 5 year billing period,⁽¹⁾ those rate changes will be passed along to the customer. Rate changes resulting in an increase of rates for an existing DS3 service with a 1, 3 or 5-year billing period will not exceed the original rate for that selected billing period. (N)

7.11.5.1 DS3 High Capacity Service Rate Description

Monthly Extension Rates

Monthly extension rates are charges that the customer may elect to be converted to at the end of their 1, 3 or 5-year billing period, until a new billing period is selected or service is disconnected. Monthly extension rates are only available once the billing period has expired.

(A) DS3 High Capacity Service Billing Period

The billing period establishes the amount of time that rates for a service are stabilized by the Utility.

The following billing periods are available for DS3 High Capacity Services and associated optional features and functions:

- Month-to-Month (D)
- Monthly Extension Rate (N)
- 1 Year (Channel Termination Only)⁽³⁾ (N)
- 3 Year (Channel Termination Only)⁽²⁾
- 5 Year (Channel Termination Only)⁽¹⁾

(D)
(D)

- (1) Effective on September 13, 2017, DS3 High Capacity Service 5-year Payment Plans are no longer available, including for any otherwise available renewals, extensions or conversions. Circuits already subject to a DS3 High Capacity Service 5-year Payment Plan, as of September 13, 2017, will continue to be provided under the then-current DS3 High Capacity Service 5-year Payment Plan term for the remainder of that term.
- (2) Effective November 1, 2022, DS1 Term Payment Plan 2- and 3-year and DS3 High Capacity Service 3-year Payment Plans (collectively, Term Plan Services), are no longer available, including conversions. Existing Term Plan Services, as of November 1, 2022, will continue to be provided under the then-current terms, for the remainder of the applicable term.
- (3) Effective January 17, 2024, DS1 Term Payment Plan 1-year and DS3 High Capacity Service 1-year Payment Plans (collectively, Term Plan Services), are no longer available, including conversions. Existing Term Plan Services on January 17, 2024, will continue to be provided for the remainder of the then-current terms. (N)

(N)
|
(N)

(This page filed under Transmittal No. 342)

7. Special Access Service (Cont'd)

7.11 High Capacity Service (Cont'd)

7.11.5.1 DS3 High Capacity Service Rate Description (Cont'd)

(A) DS3 High Capacity Service Billing Period (Cont'd)

One month prior to the expiration of the billing period, the customer must select one of the following options:

- (1) Renew the service for a specified period of time as provided in this tariff under the regulations.
- (2) Elect to be converted to monthly extension rates.
- (3) Elect to disconnect the service upon expiration of the billing period.

Extend the service for an additional 12 month⁽¹⁾ period at (N) the current rates for the existing 1, 3 or 5 year billing period. (D)

If the customer does not choose one of the preceding options prior to the expiration date of the commitment period, monthly extension rates will be applied upon expiration of the commitment period.

If a customer selects neither (1) nor (3) preceding, the current regulations for the Month-to-Month rate option will be applied to the Channel Termination upon expiration of the billing period. (D)

Option (1) as described preceding is available to customers if the term plans remain in effect and are not grandfathered. If the term plans are grandfathered and the service expires, absent customer notification, the customers expired service will be converted to monthly extension rates upon expiration.

The customer must provide the Telephone Company with a written notice of intent to extend the DS3 billing period no later than one month prior to the expiration of the service period.

(D)
|
(D)

(1) Effective January 17, 2024, DS1 Term Payment Plan 1-year and DS3 High Capacity Service 1-year Payment Plans (collectively, Term Plan Services), are no longer available, including conversions. Existing Term Plan Services on January 17, 2024, will continue to be provided for the remainder of the then-current terms. (N)
|
(N)

(This page filed under Transmittal No. 342)

7. Special Access Service (Cont'd)7.11 High Capacity Service (Cont'd)7.11.5 Rates and Charges General Description (Cont'd)7.11.5.1 DS3 High Capacity Service Rate Description^{(1) (2)} (N)
(Cont'd)(A) DS3 High Capacity Service Billing Period (Cont'd)

No nonrecurring charges will apply as long as the same number of DS3s is renewed. Any change in the number of DS3s will incur appropriate nonrecurring charges.

The customer may elect to extend an existing DS3 under a 1, 3 or 5 year billing period for a single, additional 12 month period at the current rates for the existing billing period provided the same number of DS3 circuits are being extended. (D)

If the current DS3 rates are lower than the original DS3 rates, the lower rate will be charged.

The customer must provide the Utility with a written notice of intent to extend the DS3 billing period no later than one month prior to the expiration of the service period.

An existing DS3 under a 1 or 3 year billing period may be converted to a DS3 under a longer term 3 or 5-year billing period without termination liabilities, provided that:

- (1) the expiration date for the new term agreement is beyond the end of the original term agreements,
- (2) the converted DS3 must be based upon the rates that are currently in effect and otherwise available to all customers,
- (3) the customer maintains the same or greater number of DS3 circuits under the new billing period, and
- (4) No lapse in service occurs.

(D)
(D)

- (x) Issued under authority of Special Permission No. 14-001 of the FCC in order to withdraw material filed under Transmittal No. 254 and suspended under Order DA-13-2349, released December 9, 2013, without its becoming effective and to restore currently effective material.
- (1) Effective November 1, 2022, DS1 Term Payment Plan 2- and 3-year and DS3 High Capacity Service 3-year Payment Plans (collectively, Term Plan Services), are no longer available, including conversions. Existing Term Plan Services, as of November 1, 2022, will continue to be provided under the then-current terms, for the remainder of the applicable term.
- (2) Effective January 17, 2024, DS1 Term Payment Plan 1-year and DS3 High Capacity Service 1-year Payment Plans (collectively, Term Plan Services), are no longer available, including conversions. Existing Term Plan Services on January 17, 2024, will continue to be provided for the remainder of the then-current terms. (N)
(N)

(This page filed under Transmittal No. 342)

Issued: January 2, 2024

Effective: January 17, 2024

Four AT&T Plaza, Dallas, Texas 75202

7. Special Access Service (Cont'd)

7.11 High Capacity Service (Cont'd)

7.11.5 Rates and Charges General Description (Cont'd)

7.11.5.1 DS3 High Capacity Service Rate Description^{(1) (2)} (Cont'd)

(N)

(B) DS3 High Capacity Service Termination Charges

In the event service is terminated prior to the expiration of the billing period, termination charges will apply. Termination charges do not apply to Month-to-Month service. In the event service is terminated prior to the end of the billing period, a termination charge utilizing the following termination percentage will apply:

<u>Billing Period</u>	Termination	<u>Percentage</u>
1, 3 or 5-year		45%

The termination charge is calculated as follows:

Monthly Rate	x	Months Remaining in Billing Period	x	Termination Percentage
--------------	---	---------------------------------------	---	---------------------------

Example: A customer with a \$5,000 monthly rate terminates service with 10 months remaining in a 3 year billing period. The termination charge would be calculated as follows:

$$\$5,000 \times 10 \times .45 = \$22,500$$

The termination charge would be: \$22,500

- (2) Customers requesting the termination of a DS3 under a 1, 3 or 5-year billing period prior to the expiration date of an extension of service will be charged a termination charge calculated as follows:

Number of Months Utilized of the Extension of Service	X	Current Month To Month Rate	-	Billing Period Monthly Rate
--	---	--------------------------------------	---	--------------------------------------

- (3) When a DS3 High Capacity Service, which is billed under the Shared Use provision is terminated, the termination liability will be based on the full charges as listed in 7.11.5.2 following.

- (4) A termination charge will not apply if the customer modifies service as set forth in 7.2.3 (Moves), preceding, as long as the customer maintains the same or greater number of DS3 circuits.

(x) Issued under authority of Special Permission No. 14-001 of the FCC in order to withdraw material filed under Transmittal No. 254 and suspended under Order DA-13-2349, released December 9, 2013, without its becoming effective and to restore currently effective material.

(1) Effective November 1, 2022, DS1 Term Payment Plan 2- and 3-year and DS3 High Capacity Service 3-year Payment Plans (collectively, Term Plan Services), are no longer available, including conversions. Existing Term Plan Services, as of November 1, 2022, will continue to be provided under the then-current terms, for the remainder of the applicable term.

(2) Effective January 17, 2024, DS1 Term Payment Plan 1-year and DS3 High Capacity Service 1-year Payment Plans (collectively, Term Plan Services), are no longer available, including conversions. Existing Term Plan Services on January 17, 2024, will continue to be provided for the remainder of the then-current terms.

(N)
 |
 (N)

(This page filed under Transmittal No. 342)

7. Special Access Service (Cont'd)7.11 High Capacity Service (Cont'd)7.11.5.2 DS1 Term Payment Plan (DS1 TPP)(A) General Description

The DS1 Term Payment Plan (DS1 TPP) is a term plan that allows a customer to purchase DS1 High Capacity Service over a 1, 2, 3, 5, or 7 year period. ^{(1) (2) (3)} During the term of the selected DS1 TPP, Telephone Company initiated recurring rate changes (increases or decreases) will automatically be applied to the monthly payments for the remaining months of the current DS1 TPP term. The monthly recurring rate during the DS1 TPP term will never exceed the initial DS1 TPP rate. The DS1 TPP rates can be found in Section 7.11.5.3 following. (N)

The DS1 TPP cannot be combined with other tariffed services, discounts, or pricing flexibility contracts, unless explicitly stated in the respective tariff terms and conditions.

The following recurring rate elements are included in the DS1 TPP as described in 7.2 (Rate Regulations):

- DS1 High Capacity Service Channel Termination;
- DS1 High Capacity Service Channel Mileage - Channel Mileage Facility (per mile) and Channel Mileage Termination (per termination);
- DS1 High Capacity Service Central Office Multiplexing;
- DS1 High Capacity Service Collocation Transport (Fixed and Per Mile).

(1) Effective on September 13, 2017, DS1 TPP 5- and 7-year Payment Plans are no longer available, including for any otherwise available conversions. Circuits already subject to a DS1 TPP 5- or 7-year Payment Plan, as of September 13, 2017, will continue to be provided under the then-current DS1 TPP 5- and 7-year Payment Plan term for the remainder of that term.

(2) Effective November 1, 2022, DS1 Term Payment Plan 2- and 3-year and DS3 High Capacity Service 3-year Payment Plans (collectively, Term Plan Services), are no longer available, including conversions. Existing Term Plan Services, as of November 1, 2022, will continue to be provided under the then-current terms, for the remainder of the applicable term.

(3) Effective January 17, 2024, DS1 Term Payment Plan 1-year and DS3 High Capacity Service 1-year Payment Plans (collectively, Term Plan Services), are no longer available, including conversions. Existing Term Plan Services on January 17, 2024, will continue to be provided for the remainder of the then-current terms. (N)

(This page filed under Transmittal No. 342)

7. Special Access Service (Cont'd)7.11 High Capacity Service (Cont'd)7.11.5.2 DS1 Term Payment Plan (DS1 TPP) (Cont'd)(B) Conversion of service to a new DS1 TPP or Higher Speed Service

During a customer's DS1 TPP term, conversion may be made to a new DS1 TPP term of the same or different length or an upgrade may be made to a higher speed service, if the expiration date for the new DS1 TPP term or for the new higher service is beyond the expiration of the original DS1 TPP term. The new DS1 TPP term or higher speed service must occur between the same two termination points as the original DS1 service being converted. The new DS1 TPP term or the higher speed service term becomes effective upon completion of the conversion activity. The rates, terms, and conditions applicable for the new DS1 TPP term or higher speed service will be those in effect at the time the conversion is requested. Credit for months under the previous DS1 TPP may not be transferred to the new DS1 TPP or to the higher speed service term. When all conditions described above are met, termination liability for the remaining months on the original DS1 TPP will not apply.

(Tx)

(Tx)

(C) Moves

During a DS1 TPP term a customer may move one end of a DS1 High Capacity Service to another location in the same LATA and keep the DS1 TPP in force provided the following requirements are met:

- (1) the customer must have met the minimum in-service period at the previous location and will be subject to a new minimum in-service period at the new location; and
- (2) the Move is accommodated on a single customer order with the stipulation that the BAN (Billing Account Number), the NC (Network Channel Code), ACTL (Access Customer Terminal Location) and the ECCKT (Circuit Id) are provided and are the same as for the existing circuit being moved.

(Tx)

(Tx)

(x) Issued under authority of Special Permission No. 14-001 of the FCC in order to withdraw material filed under Transmittal No. 254 and suspended under Order DA-13-2349, released December 9, 2013, without its becoming effective and to restore currently effective material.

(This page filed under Transmittal No. 257)

7. Special Access Service (Cont'd)7.11 High Capacity Service (Cont'd)7.11.5.2 DS1 Term Payment Plan (DS1 TPP) (Cont'd)(C) Moves (Cont'd)

Moves to a different wire center may result in a change in the application of the rate elements associated with the service and therefore could result in a change in the monthly recurring charges.

EXAMPLE #1: One end of a DS1 is changed from Location A to Location B within the same LATA. The new Channel Mileage associated with the one-ended Move increased by 2 miles. Therefore, the resulting Channel Mileage calculation increases the monthly recurring charge accordingly.

EXAMPLE #2: One end of a DS1 is changed from Location C to Location D within the same LATA. The new Channel Mileage associated with the one-ended Move decreased by 5 miles. Therefore, the resulting Channel Mileage calculation decreases the monthly recurring charge accordingly.

If no lapse in service occurs and if the requirements in (1) and (2) as stated previously are met, termination liability will not apply. Nonrecurring Channel Termination Charges or Nonrecurring Collocation Transport Charges for the physical move will apply.

(D) Expiration of DS1 TPP Term options

DS1 TPP is not available for renewal. At the expiration of the DS1 TPP term, the customer may select a new DS1 TPP term at the prevailing DS1 TPP rates. If a customer does not wish to purchase a new DS1 TPP at the expiration of the term, the customer's service will automatically convert to the current month-to-month rates.

(N)

(N)

(This page filed under Transmittal No. 41)

7. Special Access Service (Cont'd)7.11 High Capacity Service (Cont'd)7.11.5.2 DS1 Term Payment Plan (DS1 TPP) (Cont'd)

- (E) DS1 High Capacity Service Portability Commitment⁽²⁾
DS1 High Capacity Service Portability Commitment⁽²⁾ provides a customer the ability to establish a regional volume commitment in the form of DS1 Channel Terminations and receive a waiver on DS1 TPP Termination Liability, as described in 7.11.5.2(G), during the life of the Portability Commitment⁽²⁾. The Portability Commitment⁽²⁾ will consist of a Commitment Level (CL), as described below, and will have a term of three years. The Portability Commitment⁽²⁾ does not otherwise affect the rates, terms, or conditions of the Customer's DS1 TPP. The Portability Commitment⁽²⁾ may be renewed. To renew, the Customer must notify the Telephone Company, in writing, with such notice directed to both the Customer's account manager and the access service center, and specifically identify the Customer's Commitment Level (as defined herein), prior to the expiration of the Customer's existing Portability Commitment⁽²⁾ term.

Customers may purchase DS1 service under DS1 TPP terms of 2, 3, 5, or 7-years^{(1) (3) (4)} and have the associated Channel Terminations count towards the CL. (N)

Following are the terms and conditions associated with the Portability Commitment⁽²⁾:

- (1) Customer commits to a 3-Year Commitment Level (CL) that is reviewed on a monthly basis. The initial monthly CL is calculated by Telephone Company and is the total of all DS1 Channel Terminations in-service for the month previous to the month in which the Customer notifies the Telephone Company, in writing, of the Customer's CL. The initial monthly CL will consist of all Channel Terminations including those on Month-to-Month terms and other term pricing plans. The effective date of the Portability Commitment⁽²⁾ will be the first day of the month immediately following the month in which the Portability Commitment⁽²⁾ is signed;
- (2) Customer must have a minimum of 40 Channel Terminations in-service each month and at least 80% of the CL under a 2, 3, 5, or 7- year DS1 TPP each month;⁽¹⁾
- (3) At the commencement of the Customer's Portability Commitment⁽²⁾ and upon any renewal of a Portability Commitment, at least 80 percent of the Customer's CL must be purchased under a 2, 3, 5, or 7-year⁽¹⁾ DS1 TPP; and

- (1) Effective on September 13, 2017, DS1 TPP 5- and 7-year Payment Plans are no longer available, including for any otherwise available conversions. Circuits already subject to a DS1 TPP 5- or 7-year Payment Plan, as of September 13, 2017, will continue to be provided under the then-current DS1 TPP 5- and 7-year Payment Plan term for the remainder of that term.
- (2) Effective on October 30, 2020, new DS1 High Capacity Service Portability Commitments will no longer be available for new or existing customers, and existing Portability Commitments may no longer be renewed.
- (3) Effective November 1, 2022, DS1 Term Payment Plan 2- and 3-year and DS3 High Capacity Service 3-year Payment Plans (collectively, Term Plan Services), are no longer available, including conversions. Existing Term Plan Services, as of November 1, 2022, will continue to be provided under the then-current terms, for the remainder of the applicable term.
- (4) Effective January 17, 2024, DS1 Term Payment Plan 1-year and DS3 High Capacity Service 1-year Payment Plans (collectively, Term Plan Services), are no longer available, including conversions. Existing Term Plan Services on January 17, 2024, will continue to be provided for the remainder of the then-current terms. (N)
|
(N)

(This page filed under Transmittal No. 342)

7. Special Access Service (Cont'd)7.11 High Capacity Service (Cont'd)7.11.5.2 DS1 Term Payment Plan (DS1 TPP) (Cont'd)(E) DS1 High Capacity Service Portability Commitment^{(1) (2) (3)} (N)
(Cont'd)

- (3) Each month, the total number of 2, 3, 5, and 7-year DS1 TPP Channel Terminations for the previous month will be calculated and measured against the corresponding monthly CL;
- (a) If the total number of Channel Terminations, as calculated above, is 80% - 124% of the CL, no other charges will apply for the previous month.
- (b) If the total number of Channel Terminations, as calculated above, is less than 80% of the CL, charges will be assessed as follows:
- (i) Customer will be billed the difference between 80% of the CL and the actual number of in-service Channel Terminations. EXAMPLE #1: Customer A has a CL = 1,000 Channel Terminations for the month of June. Customer A must have at least 800 DS1 Channel Terminations in-service to meet the 80% target. In July, the monthly review calculated 795 DS1 Channel Terminations in-service for the month of June. The difference between 80% of the CL (800) and the actual in-service total (795) is 5 Channel Terminations. Therefore, the customer will be billed an amount equal to 5 Channel Terminations multiplied by the current Nonrecurring Channel Termination rate. For subsequent months, Customer A will continue to be billed an amount equal to the difference between 80% of the CL and the actual in-service number of Channel Terminations that are below 80% of the CL (multiplied) by the current nonrecurring Channel Termination rate, until 80% of the CL is met.
- (c) If the total number of in-service Channel Terminations, as calculated above, is more than 124% of the CL, the customer will be billed an adjustment factor equal to the Nonrecurring Channel Termination charge multiplied by the difference between the actual number of Channel Terminations in-service and 124% of the CL.
- (d)

- (1) Effective on October 30, 2020, new DS1 High Capacity Service Portability Commitments will no longer be available for new or existing customers, and existing Portability Commitments may no longer be renewed.
- (2) Effective November 1, 2022, DS1 Term Payment Plan 2- and 3-year and DS3 High Capacity Service 3-year Payment Plans (collectively, Term Plan Services), are no longer available, including conversions. Existing Term Plan Services, as of November 1, 2022, will continue to be provided under the then-current terms, for the remainder of the applicable term.
- (3) Effective January 17, 2024, DS1 Term Payment Plan 1-year and DS3 High Capacity Service 1-year Payment Plans (collectively, Term Plan Services), are no longer available, including conversions. Existing Term Plan Services on January 17, 2024, will continue to be provided for the remainder of the then-current terms.

(N)
|
(N)

(This page filed under Transmittal No. 342)

7. Special Access Service (Cont'd)7.11 High Capacity Service (Cont'd)7.11.5.2 DS1 Term Payment Plan (DS1 TPP) (Cont'd)(E) DS1 High Capacity Service Portability Commitment⁽¹⁾ (Cont'd) (N)

(4) (Cont'd)

(ii) EXAMPLE #2: Customer B has a CL of 500 Channel Terminations. In month 5 of the commitment, Customer B has 650 Channel Terminations in-service. Customer B has exceeded the CL by more than the 124% threshold (620). Customer B will be charged an adjustment factor equal to 30 Channel Terminations (650-620) multiplied by the current Nonrecurring Channel Termination rate. For subsequent months, Customer B will continue to be charged the Nonrecurring Channel Termination rate multiplied by the difference between the actual number of Channel Terminations in-service and 124% of the CL until Customer B no longer exceeds the CL by the 124% threshold.

(d) Customers may increase the Commitment Level (CL) at any time by providing written notification to Telephone Company. Credits for previously charged adjustments billed for exceeding the CL will not be provided when a customer increases the CL. However, an adjustment factor will not be billed if notice to increase the CL is provided to the Telephone Company within the calendar month following a reported adjustment, and the CL increase is sufficient that the number of in-service rate elements does not exceed 124% of the new CL. For instance, in Example #2 above, if the Customer increases the CL from 500 to 525 before the end of month 6, the adjustment factor applicable to month 5 will not be billed because the actual in-service volume (650) is less than or equal to the new 124% threshold (651).

⁽¹⁾ Effective on October 30, 2020, new DS1 High Capacity Service Portability Commitments will no longer be available for new or existing customers, and existing Portability Commitments may no longer be renewed.

(N)
|
(N)

(This page filed under Transmittal No. 326)

7. Special Access Service (Cont'd)

7.11 High Capacity Service (Cont'd)

7.11.5.2 DS1 Term Payment Plan (DS1 TPP) (Cont'd)

(E) DS1 High Capacity Service Portability Commitment⁽¹⁾ (Cont'd) (N)

(4) (Cont'd)

(e) If the customer elects to terminate the DS1 High Capacity Service Portability Commitment⁽¹⁾ or elects to decrease the CL prior to the 3-Year commitment, Termination Liabilities will apply. Termination Liability is calculated as the decreased number of Channel Terminations multiplied by the prevailing Month-to-Month recurring rate multiplied by the number of months remaining in the term of the Portability Commitment⁽¹⁾. (N)

(i) EXAMPLE #3: Customer C has a CL equal to 1,000 Channel Terminations. In month 10 of the 36-month Portability Commitment⁽¹⁾, Customer C elects to decrease the CL by 50 Channel Terminations. The Termination Liability associated with the decrease is equal to: (N)

(50 Channel Terminations) X (26 months remaining) X (prevailing Month-to-Month Rate)

⁽¹⁾ Effective on October 30, 2020, new DS1 High Capacity Service Portability Commitments will no longer be available for new or existing customers, and existing Portability Commitments may no longer be renewed.

(N)
|
(N)

(This page filed under Transmittal No. 326)

7. Special Access Service (Cont'd)7.11 High Capacity Service (Cont'd)7.11.5.2 DS1 Term Payment Plan (DS1 TPP)^{(2) (3)} (Cont'd)

(N)

(E) DS1 High Capacity Service Portability Commitment⁽¹⁾
(Cont'd)

(4) (Cont'd)

(ii) EXAMPLE #4: Customer D has a CL equal to 500 Channel Terminations. In month 20 of the 36-month Portability Commitment⁽¹⁾, Customer D elects to terminate the entire Portability Commitment⁽¹⁾. The Termination Liability associated with the termination of the entire commitment is equal to:

(500 Channel Terminations) X (16 months remaining) X (prevailing Month-to-Month Rate)

(F) Applicable One-Time Charges

(1) DS1 Term Payment Plan Non-Recurring Charges

Non-recurring channel termination charge will apply per channel termination on new installations of DS1 High Capacity Service on 1 year DS1 TPP term, and on all physical moves of DS1 High Capacity Services. Non-recurring channel termination charges will be waived on new installations with 2, 3, 5, and 7-year DS1 TPP terms. The Nonrecurring Channel Termination Charge will also apply, applicable as stated in 7.11.5.2(E) previously, for customers who have a DS1 High Capacity Service Portability Commitment⁽¹⁾.

(1) Effective on October 30, 2020, new DS1 High Capacity Service Portability Commitments will no longer be available for new or existing customers, and existing Portability Commitments may no longer be renewed.

(2) Effective November 1, 2022, DS1 Term Payment Plan 2- and 3-year and DS3 High Capacity Service 3-year Payment Plans (collectively, Term Plan Services), are no longer available, including conversions. Existing Term Plan Services, as of November 1, 2022, will continue to be provided under the then-current terms, for the remainder of the applicable term.

(3) Effective January 17, 2024, DS1 Term Payment Plan 1-year and DS3 High Capacity Service 1-year Payment Plans (collectively, Term Plan Services), are no longer available, including conversions. Existing Term Plan Services on January 17, 2024, will continue to be provided for the remainder of the then-current terms.

(N)

(N)

(This page filed under Transmittal No. 342)

7. Special Access Service (Cont'd)7.11 High Capacity Service (Cont'd)7.11.5.2 DS1 Term Payment Plan (DS1 TPP) (Cont'd)(G) Termination Liability

Termination liability charges will apply in the following cases:

- (1) In the event service is terminated prior to the expiration of the minimum service period, charges, as specified in Section 5.2.5 (Minimum Period), will apply in addition to the termination liability charges identified in 7.11.5.2(G) (2) following.
- (2) In the event service is terminated prior to the end of the DS1 TPP term, a termination charge utilizing the following termination percentage will apply:

Termination Billing Period Percentage: 40%

The termination charge is calculated as follows:

(Monthly Recurring Rate) X (Months remaining in DS1 TPP term) X (Termination Billing Period Percentage)

Example: A customer with a \$500 monthly rate terminates service with 10 months remaining in a 3 year DS1 TPP term. The termination liability charge would be calculated as follows:

$$(\$500) \times (10) \times (.40) = \$2000$$

(N)

(N)

(This page filed under Transmittal No. 41)

7. Special Access Service (Cont'd)

7.11 High Capacity Service (Cont'd)

7.11.5 Rates and Charges General Description (Cont'd)

7.11.5.3 Rates and Charges^{(1) (4) (5)}

(N)

Effective November 1, 2017, all rate elements, other than End User channel terminations and their applicable optional features⁽³⁾ in Non-Competitive Counties, are no longer available from Section 7.11.5.3 for new service subscriptions.⁽²⁾ The application of rates and charges for Special Access services is based upon the county classification as Competitive or Non-Competitive, as provided in Section 7.2.2. A list of Competitive and Non-Competitive Counties is located in Sections 17.2(C) and (D).

	<u>USOC</u>	<u>Monthly Rate</u>	<u>Nonrecurring Charges</u>	
(A) Channel Termination				
(Per Point of Termination)				
- 1.544 Mbps	TMECS	\$156.02 ⁽⁶⁾	\$450.00	(N)
- 3.152 Mbps	TWT++	ICB	ICB	
- 6.312 Mbps	TWT++	ICB	ICB	
-44.736 Mbps (Month-to-Month)	Z3MAC/Z3MAP	\$2,358.75	\$1,500.00	(D)
-44.736 Mbps (Monthly Extension)	Z3MAC/Z3MAP	\$2,358.75	\$1,500.00	
-44.736 Mbps (1 Year Plan)	Z3MAC/Z3MAP/Z31A+	\$1,609.50	\$1,000.00	
-44.736 Mbps (3 Year Plan)	Z3MAC/Z3MAP/Z33A+	\$870.00	\$1,000.00	
-44.736 Mbps (5 Year Plan) ⁽¹⁾	Z3MAC/Z3MAP/Z35A+	\$700.00	\$1,000.00	
-274.176 Mbps	TWT++	ICB	ICB	
(B) Channel Mileage²				
(1) Channel Mileage Facility				
(Per Mile)				
- 1.544 Mbps	1L5XX/CMF	\$9.00 ⁽⁶⁾		(N)
- 3.152 Mbps	CMF	ICB		
- 6.312 Mbps	CMF	ICB		
-44.736 Mbps (Month-to-Month)	1L5XX/CMF	\$39.00		(D)
-44.736 Mbps (Monthly Extension)	1L5XX/CMF	\$39.00		
-44.736 Mbps (1 Year Plan)	1L5XX/CMF	\$38.00		
-44.736 Mbps (3 Year Plan)	1L5XX/CMF	\$36.50		
-44.736 Mbps (5 Year Plan) ⁽¹⁾	1L5XX/CMF	\$34.00		
-274.176 Mbps	CMF	ICB		
(2) Channel Mileage Termination				
(Per Termination)				
- 1.544 Mbps	1L5XX/CMT	\$52.50 ⁽⁶⁾		(N)
- 3.152 Mbps	CMT	ICB		
- 6.312 Mbps	CMT	ICB		
-44.736 Mbps (Month-to-Month)	1L5XX/CMT	\$347.50		(D)
-44.736 Mbps (Monthly Extension)	1L5XX/CMT	\$347.50		
-44.736 Mbps (1 Year Plan)	1L5XX/CMT	\$342.50		
-44.736 Mbps (3 Year Plan)	1L5XX/CMT	\$337.50		
-44.736 Mbps (5 Year Plan) ⁽¹⁾	1L5XX/CMT	\$332.50		
-274.176 Mbps	CMT	ICB		

Note 1: ICB rates and charges are filed in 7.12 following.

Note 2: When the customer orders High Capacity Service as described in 7.11 and 7.11.5.2, preceding, the Channel Mileage Facility must be ordered in conjunction with an associated Channel Termination as described in 7.2.1(A), preceding.

(D)
(D)

- (1) Effective on September 13, 2017, DS3 High Capacity Service 5-year Payment Plans are no longer available, including for any otherwise available renewals, extensions or conversions. Circuits already subject to a DS3 High Capacity Service 5-year Payment Plan, as of September 13, 2017, will continue to be provided under the then-current DS3 High Capacity Service 5-year Payment Plan term for the remainder of that term.
- (2) Until February 1, 2018, End User channel terminations and their applicable optional features that had not qualified for Phase II, Level 2 pricing flexibility prior to June 1, 2017, will be rated at the price cap rate regardless of the status of the county in which the applicable wire center is located.
- (3) Optional features for End User channel terminations includes all optional features in Section 7, except for the Transfer Arrangement.
- (4) Effective November 1, 2022, DS1 Term Payment Plan 2- and 3-year and DS3 High Capacity Service 3-year Payment Plans (collectively, Term Plan Services), are no longer available, including conversions. Existing Term Plan Services, as of November 1, 2022, will continue to be provided under the then-current terms, for the remainder of the applicable term.
- (5) Effective January 17, 2024, DS1 Term Payment Plan 1-year and DS3 High Capacity Service 1-year Payment Plans (collectively, Term Plan Services), are no longer available, including conversions. Existing Term Plan Services on January 17, 2024, will continue to be provided for the remainder of the then-current terms.
- (6) Rate applies to both Month-to-Month and Monthly Extension.

(N)
|
(N)

(This page filed under Transmittal No. 342)

7. Special Access Service (Cont'd)

7.11 High Capacity Service

7.11.5 Rates and Charges General Description (Cont'd)

7.11.5.3 Rates and Charges (Cont'd)

	<u>USOC</u>	<u>Monthly Rate</u>	
(C) <u>Optional Features and Functions</u>			
(1) Multiplexing, per arrangement			
DS4 to DS1	MXA++	ICB	
DS3 to DS1			(D)
Month-to-Month*	MQ3	\$425.00	
Monthly Extension	MQ3	\$425.00	
1 Year ⁽⁵⁾	MQ3	\$420.00	(N)
3 Year ⁽⁴⁾	MQ3	\$410.00	(N)
5 Year ⁽²⁾	MQ3	\$400.00	
DS2 to DS1	MXD++	ICB	
DS1C to DS1	MXH++	ICB	
DS1 to Voice/Digital* ⁽³⁾	MQ1/MQ1++	\$170.00	
DS1 to DS0 ⁽³⁾	QMU/QMUA1/QMU+**	\$170.00	
DS0 to Subrates ⁽³⁾			
-Up to 20 2.4 kbps services	QSU24	\$175.00	
-Up to 10 4.8 kbps services	QSU48	\$175.84	
-Up to 5 9.6 kbps services	QSU96	\$125.00	

* A channel of this DS1 to a multiplexing Hub can be used for Digital Data Service

** QMU and QMUA1 are used in CABS. QMU++ is used in CRIS billing system. ICB rates and charges are filed in 7.12, following.

⁽¹⁾ [DELETED] (D)

⁽²⁾ Effective on September 13, 2017, DS3 High Capacity Service 5-year Payment Plans are no longer available, including for any otherwise available renewals, extensions or conversions. Circuits already subject to a DS3 High Capacity Service 5-year Payment Plan, as of September 13, 2017, will continue to be provided under the then-current DS3 High Capacity Service 5-year Payment Plan term for the remainder of that term.

⁽³⁾ Effective November 20, 2019, this Service will no longer be available for purchase by new or existing customers, and service agreements may no longer be renewed. In addition, requests to move, add or change existing service arrangements will not be accepted. Following the expiration of a customer's existing term agreement, service will be provided on a month-to-month basis at the applicable monthly extension rates until the service is discontinued. AT&T currently plans to discontinue this Service on or after June 30, 2024.

⁽⁴⁾ See Page 7-79 for Service availability. (N)

⁽⁵⁾ Effective January 17, 2024, DS1 Term Payment Plan 1-year and DS3 High Capacity Service 1-year Payment Plans (collectively, Term Plan Services), are no longer available, including conversions. Existing Term Plan Services on January 17, 2024, will continue to be provided for the remainder of the then-current terms. (N)

(This page filed under Transmittal No. 342)

7. Special Access Service (Cont'd)

7.11 High Capacity Service

7.11.5 Rates and Charges General Description (Cont'd)

7.11.5.3 Rates and Charges (Cont'd)

		<u>Monthly</u>	<u>Nonrecurring</u>			
		<u>USOC</u>	<u>Rate</u>	<u>Rate</u>		
(C) <u>Optional Features and Functions</u> (Cont'd)						
(2)	Multiplexer Cross-Connect - per cross-connect, per central office	1L5TC	\$10.00	\$80.00		
(3)	Transfer Arrangement (dial-up*) - per four port arrangement including control channel termination**	USV	ICB			
(D) <u>DS1/DS3 Rollover</u>						
		<u>USOC</u>			<u>Nonrecurring</u>	
					<u>Charge</u>	
	-per DS1 Channel Termination	NRBR1/NRBRH/SVR***		\$450.00		
	-per DS3 Channel Termination	NRBR3/SVR		900.00		
(E) <u>Collocation Transport</u>						
		<u>USOC</u>	<u>Monthly Rate</u>		<u>Nonrecurring</u>	
			<u>Fixed</u>	<u>Per Mile</u>	<u>1st Ckt.</u>	<u>Addl Ckt.</u>
1.544 Mbps	(1H48S)		\$52.50	\$9.00	\$300.00	\$300.00
		<u>USOC</u>	<u>Monthly Rate</u>		<u>Nonrecurring</u>	
			<u>Fixed</u>	<u>Per Mile</u>	<u>1st Ckt.</u>	<u>Addl Ckt.</u>
44.736 Mbps	(1H48S)					
	Month-to-Month		\$347.35	\$39.00	\$1,500.00	\$1,500.00 (D)
	Monthly Extension		\$347.35	\$39.00		
	1 Year Plan ⁽⁴⁾		\$342.50	\$38.00	\$1,000.00	\$1,000.00 (N)
	3 Year Plan ⁽³⁾		\$337.50	\$36.50	\$1,000.00	\$1,000.00 (N)
	5 Year Plan ⁽²⁾		\$332.50	\$34.00	\$1,000.00	\$1,000.00 (N)

* The Dial-Up option requires the customer to purchase the Controller Arrangement from 13.3.7, following.

* An additional Channel Termination charge will apply whenever a spare channel is configured as a leg to the customer premises. Additional channel mileage charges will also apply when the transfer arrangement is not located in the customer premises serving wire center

*** NRBR1 and NRBRH are used in CABS. SVR is used in CRIS billing system.

⁽¹⁾ [DELETED] (D)

⁽²⁾ Effective on September 13, 2017, DS3 High Capacity Service 5-year Payment Plans are no longer available, including for any otherwise available renewals, extensions or conversions. Circuits already subject to a DS3 High Capacity Service 5-year Payment Plan, as of September 13, 2017, will continue to be provided under the then-current DS3 High Capacity Service 5-year Payment Plan term for the remainder of that term.

⁽³⁾ See Page 7-79 for Service availability. (N)

⁽⁴⁾ Effective January 17, 2024, DS1 Term Payment Plan 1-year and DS3 High Capacity Service 1-year Payment Plans (collectively, Term Plan Services), are no longer available, including conversions. Existing Term Plan Services on January 17, 2024, will continue to be provided for the remainder of the then-current terms. (N)

(This page filed under Transmittal No. 342)

ACCESS SERVICE

7. Special Access Service (Cont'd)
 7.11 High Capacity Service
 7.11.5 Rates and Charges General Description (Cont'd)
 7.11.5.3 Rates and Charges (Cont'd)

(F) DS1 Term Payment Plan
 Rates and Charges for the DS1 Term Payment Plan ^{(1) (3) (4)}

(N)

	(1) Channel Termination				
	- Per Point of Termination				
USOC	1 Year	2 Year	3 Year	5 Year	7 Year
TMECS	\$152.29	\$134.40	\$128.80	\$104.00	\$98.50
	(2) Channel Mileage				
	- Channel Mileage Termination (per termination)				
USOC	1 Year	2 Year	3 Year	5 Year	7 Year
1L5XX	\$ 51.00	\$ 45.00	\$ 40.00	\$ 35.00	\$ 32.50
	- Channel Mileage Facility (per mile)				
USOC	1 Year	2 Year	3 Year	5 Year	7 Year
1L5XX	\$ 9.00	\$ 9.00	\$ 8.70	\$ 8.40	\$ 8.25
	(3) Central Office Multiplexing DS1 to DS0 voice/digital ⁽²⁾				
	-Per arrangement				
USOC	1 Year	2 Year	3 Year	5 Year	7 Year
MQ1, MQ1++, QMU, QMUA1, QMU++	\$180.00	\$170.00	\$170.00	\$ 160.00	\$150.00
	(4) Collocation Transport				
	-Channel Mileage				
	- Fixed				
USOC	1 Year	2 Year	3 Year	5 Year	7 Year
1H48S	\$ 51.00	\$ 45.00	\$ 40.00	\$ 35.00	\$ 32.50
	- Per Mile				
USOC	1 Year	2 Year	3 Year	5 Year	7 Year
1H48S	\$ 9.25	\$ 9.00	\$ 8.75	\$ 8.50	\$ 8.25
	(5) Nonrecurring Charges-One Time Charges				
	- Per point of channel termination				

USOC	DESCRIPTION	RATE
TMECS	Channel Termination Nonrecurring Charge	\$ 900.00
1H48S	Collocation Transport Nonrecurring Charge	

NOTE: Channel Termination Nonrecurring Charges and Collocation Transport Nonrecurring Charges are waived on new installations of DS1 High Capacity Service with a 2, 3, 5, or 7-year DS1 TPP.

- (1) Effective on September 13, 2017, DS1 TPP 5- and 7-year Payment Plans are no longer available, including for any otherwise available conversions. Circuits already subject to a DS1 TPP 5- or 7-year Payment Plan, as of September 13, 2017, will continue to be provided under the then-current DS1 TPP 5- and 7-year Payment Plan term for the remainder of that term.
- (2) Effective November 20, 2019, this Service will no longer be available for purchase by new or existing customers, and service agreements may no longer be renewed. In addition, requests to move, add or change existing service arrangements will not be accepted. Following the expiration of a customer's existing term agreement, service will be provided on a month-to-month basis at the applicable monthly extension rates until the service is discontinued. AT&T currently plans to discontinue this Service on or after June 30, 2024.
- (3) Effective November 1, 2022, DS1 Term Payment Plan 2- and 3-year and DS3 High Capacity Service 3-year Payment Plans (collectively, Term Plan Services), are no longer available, including conversions. Existing Term Plan Services, as of November 1, 2022, will continue to be provided under the then-current terms, for the remainder of the applicable term.
- (4) Effective January 17, 2024, DS1 Term Payment Plan 1-year and DS3 High Capacity Service 1-year Payment Plans (collectively, Term Plan Services), are no longer available, including conversions. Existing Term Plan Services on January 17, 2024, will continue to be provided for the remainder of the then-current terms.

(N)
 |
 (N)

(This page filed under Transmittal No. 342)

7. Special Access Service (Cont'd)7.12 Fractional DS1 Service⁽¹⁾

(N)

(A) Basic Channel Description

A Fractional DS1 channel provides for the digital transmission of nominal 128, 256, 384, 512, 768 kbps, serial data. The actual bit rate is a function of the channel interface selected by the customer. Fractional DS1 channels are provided for two-point service between customer designated premises or between a customer designated premises and a Telephone Company Digital Hub. Rates for Fractional DS1 Service can be found in Section 7.12.1.

When a single Fractional DS1 channel is ordered to be terminated at a customer's designated POP, which requires a minimum digital interface level at 1.544 Mbps, the Telephone Company will provide the required interface where facilities are available.

Fractional DS1 service is offered only where equipment and facilities are available. Fractional DS1 service is provisioned from specific wire centers which are listed in the National Exchange Carrier Association, Inc. Tariff F.C.C. No. 4. (T)
Availability is not restricted to customers serviced by the wire centers listed in Tariff F.C.C. No. 4, but the service must be (T)
routed through the designated offices in Tariff F.C.C. No. 4. (T)
Mileage, as defined in Section 7.2.5 (Mileage Measurement) will (T)
apply.

It is the customer's responsibility to arrange for the Channel Service Unit-type equipment or other Network Channel Terminating Equipment associated with the Fractional DS1 channel at the customer premises.

Rates and charges for Fractional DS1 Service can be found in Section 7.12.1. (D)

⁽¹⁾ Effective October 27, 2016, Fractional DS1 Service is limited to existing Customers for existing service arrangements; no new or additional term commitments of any kind, including any otherwise available renewals, will be available; and no move, add, or change orders will be accepted. (N)
(N)

(This page filed under Transmittal No. 297)

7. Special Access Service (Cont'd)

7.12 Fractional DS1 Service⁽¹⁾ (Cont'd) (N)

(B) Technical Specifications Packages

Technical Specifications Package HC1 will apply for all speeds of Fractional DS1 Service.

A Fractional DS1 channel with Technical Specifications Package HC1 will be capable of an error-free second performance of 98.75% over a continuous 24 hour period as measured at the 1.544 Mbps rate through a Channel Service Unit equivalent which is designed, manufactured, and maintained to conform with the specifications contained in the Technical Reference for High Capacity Service.

(C) Channel Interfaces (CI)

The following channel interfaces define the bit rates that are available for a Fractional DS1 channel:

CI	Bit Rate
DS-1S128,	256, 384, 512, 768 kbps

(D) Termination Liability for Fractional DS1 Services Purchased Under a Three or Five Year Term

Termination liability charges will apply in the following cases:

- (1) In the event service is terminated prior to the expiration of the minimum service period, charges, specified in Section 5.2.5, will apply in addition to the termination liability charges identified in Section 7.12(D) (2). (D)
(T)

- (2) In the event service is terminated prior to the end of the Fractional DS1 term, a termination charge utilizing the following termination percentage will apply:

Termination Billing Period Percentage: 40%

The termination charge is calculated as follows:

(Monthly Recurring Rate) X (Months remaining in term) X (Termination Billing Period Percentage)

Example: A customer with a \$500 monthly rate terminates service with 10 months remaining in a 3 year Fractional DS1 term. The termination liability charge would be calculated as follows:

$$(\$500) \times (10) \times (.40) = \$2000$$

⁽¹⁾ Effective October 27, 2016, Fractional DS1 Service is limited to existing Customers for existing service arrangements; no new or additional term commitments of any kind, including any otherwise available renewals, will be available; and no move, add, or change orders will be accepted. (N)
(N)

(This page filed under Transmittal No. 297)

7. Special Access Service (Cont'd)

7.12 Fractional DS1 Service⁽¹⁾ (Cont'd)

7.12.1 Rates and Charges - 128, 256, 384, 512, and 768 Kbps

Effective November 1, 2017, the application of rates and charges for Special Access services is based upon the county classification as Competitive or Non-Competitive, as provided in Section 7.2.2. A list of Competitive and Non-Competitive Counties is located in Sections 17.2(C) and (D).

(N)
 |
 (N)

(A) Channel Termination

- Per Point of Termination TMECS

	Recurring Charges	Nonrecurring Charges	
		1st CKT	Addl CKT
MTM	\$125.00	\$900.00	\$900.00
3 Year	\$115.00	\$900.00	\$900.00
5 Year	\$105.00	\$900.00	\$900.00

**(B) Channel Mileage
 - Fixed**

USOC	MTM	3 Year	5 Year
1L5XX	\$50.00	\$35.00	\$30.00

**Channel Mileage
 - Per Mile**

USOC	MTM	3 Year	5 Year
1L5XX	\$9.00	\$8.25	\$8.00

⁽¹⁾ Effective October 27, 2016, Fractional DS1 Service is limited to existing Customers for existing service arrangements; no new or additional term commitments of any kind, including any otherwise available renewals, will be available; and no move, add, or change orders will be accepted.

(This page filed under Transmittal No. 304)

ACCESS SERVICE

7. Special Access Service (Cont'd)

7.13⁽¹⁾

(D)

⁽¹⁾ Material in this Section has been de-tariffed as required by the Commission upon use of the forbearance relief pursuant to FCC Memorandum Opinion and Order No. 07-180, released October 12, 2007. Terms and Conditions associated with de-tariffed services are available at www.att.com/guidebook.

(This page filed under Transmittal No. 176)

Issued: January 24, 2008

Effective: February 8, 2008

Four AT&T Plaza, Dallas, Texas 75202

ACCESS SERVICE

7. Special Access Service (Cont'd)

7.13⁽¹⁾

(D)

⁽¹⁾ See footnote (1) on page 7-86.

(This page filed under Transmittal No. 176)

Issued: January 24, 2008

Effective: February 8, 2008

Four AT&T Plaza, Dallas, Texas 75202

ACCESS SERVICE

7. Special Access Service (Cont'd)

7.13⁽¹⁾

(D)

⁽¹⁾ See footnote (1) on page 7-86.

(This page filed under Transmittal No. 176)

Issued: January 24, 2008

Effective: February 8, 2008

Four AT&T Plaza, Dallas, Texas 75202

ACCESS SERVICE

7. Special Access Service (Cont'd)

7.13⁽¹⁾

(D)

⁽¹⁾ See footnote (1) on page 7-86.

(This page filed under Transmittal No. 176)

Issued: January 24, 2008

Effective: February 8, 2008

Four AT&T Plaza, Dallas, Texas 75202

ACCESS SERVICE

7. Special Access Service (Cont'd)

7.13⁽¹⁾

(D)

⁽¹⁾ See footnote (1) on page 7-86.

(This page filed under Transmittal No. 176)

Issued: January 24, 2008

Effective: February 8, 2008

Four AT&T Plaza, Dallas, Texas 75202

ACCESS SERVICE

7. Special Access Service (Cont'd)

7.13⁽¹⁾

(D)

⁽¹⁾ See footnote (1) on page 7-86.

(This page filed under Transmittal No. 176)

Issued: January 24, 2008

Effective: February 8, 2008

Four AT&T Plaza, Dallas, Texas 75202

ACCESS SERVICE

7. Special Access Service (Cont'd)

7.13⁽¹⁾

(D)

⁽¹⁾ See footnote (1) on page 7-86.

(This page filed under Transmittal No. 176)

Issued: January 24, 2008

Effective: February 8, 2008

Four AT&T Plaza, Dallas, Texas 75202

ACCESS SERVICE

7. Special Access Service (Cont'd)

7.13⁽¹⁾

(D)

⁽¹⁾ See footnote (1) on page 7-86.

(This page filed under Transmittal No. 176)

Issued: January 24, 2008

Effective: February 8, 2008

Four AT&T Plaza, Dallas, Texas 75202

ACCESS SERVICE

7. Special Access Service (Cont'd)

7.13⁽¹⁾

(D)

⁽¹⁾ See footnote (1) on page 7-86.

(This page filed under Transmittal No. 176)

Issued: January 24, 2008

Effective: February 8, 2008

Four AT&T Plaza, Dallas, Texas 75202

ACCESS SERVICE

7. Special Access Service (Cont'd)

7.13⁽¹⁾

(D)

⁽¹⁾ See footnote (1) on page 7-86.

(This page filed under Transmittal No. 176)

Issued: January 24, 2008

Effective: February 8, 2008

Four AT&T Plaza, Dallas, Texas 75202

ACCESS SERVICE

7. Special Access Service (Cont'd)

7.13⁽¹⁾

(D)

⁽¹⁾ See footnote (1) on page 7-86.

(This page filed under Transmittal No. 176)

ACCESS SERVICE

7. Special Access Service (Cont'd)

7.13⁽¹⁾

(D)

⁽¹⁾ See footnote (1) on page 7-86.

(This page filed under Transmittal No. 176)

ACCESS SERVICE

7. Special Access Service (Cont'd)

7.13⁽¹⁾

(D)

⁽¹⁾ See footnote (1) on page 7-86.

(This page filed under Transmittal No. 176)

Issued: January 24, 2008

Effective: February 8, 2008

Four AT&T Plaza, Dallas, Texas 75202

ACCESS SERVICE

7. Special Access Service (Cont'd)

7.13⁽¹⁾

(D)

⁽¹⁾ See footnote (1) on page 7-86.

(This page filed under Transmittal No. 176)

ACCESS SERVICE

7. Special Access Service (Cont'd)

7.13⁽¹⁾

(D)

⁽¹⁾ See footnote (1) on page 7-86.

(This page filed under Transmittal No. 176)

Issued: January 24, 2008

Effective: February 8, 2008

Four AT&T Plaza, Dallas, Texas 75202

ACCESS SERVICE

7. Special Access Service (Cont'd)

7.13⁽¹⁾

(D)

⁽¹⁾ See footnote (1) on page 7-86.

(This page filed under Transmittal No. 176)

Issued: January 24, 2008

Effective: February 8, 2008

Four AT&T Plaza, Dallas, Texas 75202

ACCESS SERVICE

7. Special Access Service (Cont'd)

7.13⁽¹⁾

(D)

⁽¹⁾ See footnote (1) on page 7-86.

(This page filed under Transmittal No. 176)

Issued: January 24, 2008

Effective: February 8, 2008

Four AT&T Plaza, Dallas, Texas 75202

ACCESS SERVICE

7. Special Access Service (Cont'd)

7.13⁽¹⁾

(D)

⁽¹⁾ See footnote (1) on page 7-86.

(This page filed under Transmittal No. 176)

Issued: January 24, 2008

Effective: February 8, 2008

Four AT&T Plaza, Dallas, Texas 75202

ACCESS SERVICE

7. Special Access Service (Cont'd)

7.13⁽¹⁾

(D)

⁽¹⁾ See footnote (1) on page 7-86.

(This page filed under Transmittal No. 176)

Issued: January 24, 2008

Effective: February 8, 2008

Four AT&T Plaza, Dallas, Texas 75202

ACCESS SERVICE

7. Special Access Service (Cont'd)

7.13⁽¹⁾

(D)

⁽¹⁾ See footnote (1) on page 7-86.

(This page filed under Transmittal No. 176)

Issued: January 24, 2008

Effective: February 8, 2008

Four AT&T Plaza, Dallas, Texas 75202

ACCESS SERVICE

7. Special Access Service (Cont'd)

7.13⁽¹⁾

(D)

⁽¹⁾ See footnote (1) on page 7-86.

(This page filed under Transmittal No. 176)

Issued: January 24, 2008

Effective: February 8, 2008

Four AT&T Plaza, Dallas, Texas 75202

ACCESS SERVICE

7. Special Access Service (Cont'd)

7.13⁽¹⁾

(D)

⁽¹⁾ See footnote (1) on page 7-86.

(This page filed under Transmittal No. 176)

Issued: January 24, 2008

Effective: February 8, 2008

Four AT&T Plaza, Dallas, Texas 75202

ACCESS SERVICE

7. Special Access Service (Cont'd)

7.13⁽¹⁾

(D)

⁽¹⁾ See footnote (1) on page 7-86.

(This page filed under Transmittal No. 176)

Issued: January 24, 2008

Effective: February 8, 2008

Four AT&T Plaza, Dallas, Texas 75202

ACCESS SERVICE

7. Special Access Service (Cont'd)

7.13⁽¹⁾

(D)

⁽¹⁾ See footnote (1) on page 7-86.

(This page filed under Transmittal No. 176)

Issued: January 24, 2008

Effective: February 8, 2008

Four AT&T Plaza, Dallas, Texas 75202

7. Special Access Service (Cont'd)

7.14 Individual Case Filings

Rates and charges for Special Access Service provided on an individual case basis are filed following:

(M)
(T)
(M)
|
(M)

Certain material appearing on this page previously appeared on Original Page 7-85.

(This page filed under Transmittal No. 63)

Issued: April 13, 2004

Effective: April 14, 2004

Four AT&T Plaza, Dallas, Texas 75202