

OTHER SERVICES

D13. ADVANCED SERVICES

(D)

(D)

CC: 5170

OTHER SERVICES
 D13. ADVANCED SERVICES

LIST OF EFFECTIVE SHEET

Sheets listed below are effective as of the date shown on each sheet.

| <u>Revision Number</u> | <u>Sheet</u> | <u>Revision Number</u> | <u>Sheet</u> |
|----------------------------|--------------|----------------------------|--------------|
| 13th | CS A | 5th | 8 |
| 14th ¹ | CS A | 5th | 9 |
| 5th | ToC A | 4th | 10 |
| 5th | 1 | 5th ¹ | 10 |
| 6th ¹ | 1 | 4th | 11 |
| 4th | 2 | 5th | 12 |
| 6th | 2.1 | 6th | 13 |
| 7th ¹ | 2.1 | 4th | 14 |
| Original | 2.2 | 5th | 15 |
| 5th | 3 | 6th ¹ | 15 |
| 6th ¹ | 3 | 8th | 16 |
| 2nd | 3.1 | 9th ¹ | 16 |
| 3rd ¹ | 3.1 | 5th ¹ | 17 |
| Original ¹ | 3.2 | 1st | 18 |
| 6th | 4 | 1st | 19 |
| 7th | 5 | 2nd | 20 |
| 5th | 5.1 | 1st | 21 |
| 6th ¹ | 5.1 | 1st | 22 |
| 5th | 5.2 | 2nd | 23 |
| 5th | 5.3 | 1st | 24 |
| 5th | 5.4 | 1st | 25 |
| 3rd | 5.5 | 1st | 26 |
| 3rd | 5.6 | 2nd | 27 |
| 3rd | 5.7 | 2nd | 28 |
| 4th ¹ | 5.7 | 2nd | 29 |
| 1st | 5.8 | 1st | 29.1 |
| 2nd ¹ | 5.8 | 2nd | 30 |
| 5th | 6 | 2nd | 31 |
| 6th ¹ | 6 | 2nd | 32 |
| 5th | 7 | 2nd | 33 |
| 6th ¹ | 7 | | |

NOTE 1: Issued

CC: 5170

OTHER SERVICES

Sheet Numbers Table of Contents A through Sheet 33.

(N)
(D)

(D)

OTHER SERVICES

(T)

D13. ADVANCED SERVICES

TABLE OF CONTENTS

| | <u>Sheet No.</u> | |
|--|------------------|-----|
| 13.1 OPT-E-MAN® | 1 | |
| A. GENERAL DESCRIPTION | 1 | |
| B. SERVICE PROVISIONING | 2 | |
| C. RATE REGULATIONS | 6 | |
| D. RESERVED | 12 | (T) |
| E. RATES AND CHARGES | 15 | (T) |
| | | |
| 13.2 CUSTOMIZED SWITCHED METRO ETHERNET (CSME) SERVICE | 18 | |
| A. GENERAL DESCRIPTION | 18 | |
| B. SERVICE PROVISIONING | 19 | |
| C. RATE REGULATIONS | 25 | |
| D. RESERVED | 30 | (T) |
| E. RATES AND CHARGES | 32 | (T) |

OTHER SERVICES
D13. ADVANCED SERVICES

13.1 OPT-E-MAN® (Cont'd)

A. GENERAL DESCRIPTION

1. Service Description

OPT-E-MAN® Service is an advanced service offering networking capabilities utilizing Optical Ethernet. Optical Ethernet is the use of Ethernet LAN packets running over optical fiber within or as access to a service provider's network. OPT-E-MAN provides an integrated service consisting of fiber and/or copper transport (at the Utility's discretion) connected to an Ethernet device capable of switching and routing. OPT-E-MAN will provide bandwidth ranging from 2 Mbps to 1 Gbps. Customers will connect to the service using a router, bridge or switch.

(C)
|
(C)

OPT-E-MAN supports a logical point-to-point, point-to-multi-point or multipoint-to-multipoint configuration and enables the customer to connect locations within the Local Access and Transport Area (LATA) or Metropolitan Area Network (MAN) as if they were segments on the same LAN.

Customers may connect any two or more locations together when utilizing a point-to-point or point-to-multipoint configuration, and a minimum of three or more locations when utilizing a multipoint-to-multipoint configuration.¹

OPT-E-MAN Service provides the customer the capability to connect to the Utility's Ethernet network, where facilities exist, via one of the following standard network interfaces:

10/100BaseT (100 Mbps)

(T)

1 Gbps Ethernet (1000BaseSX, 1000BaseLX/LH or 1000BaseZX)²

(T)

OPT-E-MAN service includes the transport from the customer's premises to the Ethernet network, a port on the Ethernet network, a Committed Information Rate (CIR) and Ethernet Virtual Connections (EVC).

Network Terminating Equipment (NTE) will be placed at the customer's premises as part of the OPT-E-MAN Service. The NTE functions as a switching and routing device.

A detailed description of the rate elements and how they are applied can be found in C. Rate Regulations, following.

Specifications for ordering OPT-E-MAN service rate elements are identified in B.2. Ordering Specifications and Provisioning, following.

NOTE 1: Applicable to new service installed after November 29, 2006.
NOTE 2: Includes allowances for overhead within the Utility's Ethernet Network. If the customer orders 1 Gbps of CIR on a single port, the Utility reserves the right to use up to 10% of bandwidth for traffic management.

Continued

OTHER SERVICES

D13. ADVANCED SERVICES

13.1 OPT-E-MAN® (Cont'd)

B. SERVICE PROVISIONING

1. Manner of Provisioning

a. Provisioning of this service is subject to the availability and operational limitations of the Utility's equipment and associated facilities. Where facilities and/or operating conditions are not available, Special Construction charges as set forth in Schedule Cal. P.U.C No. 175-T, Section 15. may apply.

b. Reserved

(T)
(D)
(D)

c. Access into the Utility's network must conform to industry standards and specifications as set forth in the Utility's technical publication.

d. The Utility will provision up to and including the Network Terminating Equipment (NTE). The Utility will place NTE at either a Multi-Tenant Unit (MTU) or Single Tenant Unit (STU). MTU NTEs are shared among multiple customers. The placement of the NTE shall be located in a manner consistent with federal and state regulatory requirements. This location will be at each customer's premises, unless specified otherwise and agreed to by the Utility.

e. NTEs installed by the Utility on the customer's premises shall remain the property of the Utility. The customer or user may not rearrange, disconnect, remove, attempt to repair, remote test or interface with any network equipment installed by the Utility without prior written consent of the Utility.

f. The customer shall be responsible for obtaining permission for the Utility's agents or employees to enter the customer's premises at a mutually agreed upon time for the purpose of installing, inspecting, repairing, or removing (upon termination of the service) the equipment of the Utility.

g. The operating characteristics of customer provided equipment (CPE) used in connection with OPT-E-MAN® must not interfere with the Utility's OPT-E-MAN® network. CPE must not:

- (1) Endanger the safety of the Utility's employees or the public;
- (2) Damage, harm, require change in or alteration of the equipment or other services of the Utility; or
- (3) Interfere with the proper operation of the Utility's equipment.

Continued

OTHER SERVICES
D13. ADVANCED SERVICES

(T)

13.1 OPT-E-MAN® (Cont'd)

B. SERVICE PROVISIONING

1. Manner of Provisioning

a. Provisioning of this service is subject to the availability and operational limitations of the Utility's equipment and associated facilities. Where facilities and/or operating conditions are not available, Special Construction charges as set forth in Schedule Cal. P.U.C No. 175-T, Section 15. may apply. (T)

b. OPT-E-MAN® service is available in Utility Central Offices as specified in National Exchange Carrier Association, Inc. Tariff F.C.C. No. 4 (NECA Tariff F.C.C No. 4).

c. Access into the Utility's network must conform to industry standards and specifications as set forth in the Utility's technical publication.

d. The Utility will provision up to and including the Network Terminating Equipment (NTE). The Utility will place NTE at either a Multi-Tenant Unit (MTU) or Single Tenant Unit (STU). MTU NTEs are shared among multiple customers. The placement of the NTE shall be located in a manner consistent with federal and state regulatory requirements. This location will be at each customer's premises, unless specified otherwise and agreed to by the Utility.

e. NTEs installed by the Utility on the customer's premises shall remain the property of the Utility. The customer or user may not rearrange, disconnect, remove, attempt to repair, remote test or interface with any network equipment installed by the Utility without prior written consent of the Utility.

f. The customer shall be responsible for obtaining permission for the Utility's agents or employees to enter the customer's premises at a mutually agreed upon time for the purpose of installing, inspecting, repairing, or removing (upon termination of the service) the equipment of the Utility.

g. The operating characteristics of customer provided equipment (CPE) used in connection with OPT-E-MAN® must not interfere with the Utility's OPT-E-MAN® network. CPE must not:

- (1) Endanger the safety of the Utility's employees or the public;
- (2) Damage, harm, require change in or alteration of the equipment or other services of the Utility; or
- (3) Interfere with the proper operation of the Utility's equipment.

Continued

OTHER SERVICES

D13. ADVANCED SERVICES

13.1 OPT-E-MAN® (Cont'd)

B. SERVICE PROVISIONING (Cont'd)

1. Manner of Provisioning (Cont'd)

h. Upon notice from the Utility that the CPE is causing, or is likely to cause, such hazard or interference, the customer shall take such steps as necessary to remove or prevent such hazard or interference.

i. OPT-E-MAN Service supports full duplex communication.

j. If a customer connects to the OPT-E-MAN network using a bridge or switch for Layer 2 connectivity, only 50 Media Access Control (MAC) addresses can be used per Layer 2 device, per port. Any additional addresses will be assessed additional charges, with a limit of 100 MAC addresses total per port as set forth in E. Current Rates and Charges, following.

k. Repeater technology may be used for customers requesting OPT-E-MAN service from a serving wire center not equipped to provide OPT-E-MAN service or if customers are outside the technical limits of an Ethernet equipped Central Office. A technical review will be necessary to determine if service can be provided. Only one repeater can be used on a connection between the Ethernet equipped Central Office and the customer premises. A repeater will incur additional charges as set forth in E. following.

l. The CIR selected by the customer must be committed to for a 30 day period before an increase in the CIR can be requested.

m. OPT-E-MAN Service may be available in a meet-point billing arrangement (C) involving another Incumbent Local Exchange Carrier (ILEC) (sometimes also (C) referred to as an Independent Company or ICO), where suitable facilities (N) exist and where appropriate procedures for such arrangements have been put in place between the Company and the other ILEC. When the Company and another ILEC jointly provision OPT-E-MAN Service with the other ILEC's service, the ILEC involved shall bill the customer at that ILEC's applicable rates for their portion of the service located in their operating territory. Ordering and provisioning procedures may vary, and therefore Meet-Point rate elements and charges may not be applicable, when the other ILEC involved in the Meet-Point arrangement is an AT&T ILEC. (N)

n. A Letter of Authorization will need to be established if customers want to purchase a logical connection via an EVC to another provider (IXC, ISP or other) in order to ensure security and accuracy in the connection.

Material omitted now located on Sheet 2.2.

(N)

Continued

OTHER SERVICES
D13. ADVANCED SERVICES

13.1 OPT-E-MAN® (Cont'd)

B. SERVICE PROVISIONING (Cont'd)

1. Manner of Provisioning (Cont'd)

h. Upon notice from the Utility that the CPE is causing, or is likely to cause, such hazard or interference, the customer shall take such steps as necessary to remove or prevent such hazard or interference.

i. OPT-E-MAN Service supports full duplex communication.

j. If a customer connects to the OPT-E-MAN network using a bridge or switch for Layer 2 connectivity, only 50 Media Access Control (MAC) addresses can be used per Layer 2 device, per port. Any additional addresses will be assessed additional charges, with a limit of 100 MAC addresses total per port as set forth in E. Current Rates and Charges, following.

k. Repeater technology may be used for customers requesting OPT-E-MAN service from a serving wire center not equipped to provide OPT-E-MAN service or if customers are outside the technical limits of an Ethernet equipped Central Office. A technical review will be necessary to determine if service can be provided. Only one repeater can be used on a connection between the Ethernet equipped Central Office and the customer premises. A repeater will incur additional charges as set forth in E. following.

l. The CIR selected by the customer must be committed to for a 30 day period before an increase in the CIR can be requested.

m. OPT-E-MAN Service is not available in a meet-point billing arrangement involving other Carriers.

n. A Letter of Authorization will need to be established if customers want to purchase a logical connection via an EVC to another provider (IXC, ISP or other) in order to ensure security and accuracy in the connection.

o. For Basic Service, a total of 8 Ethernet Virtual Connections (EVCs) may be configured per 10/100BaseT connection. A total of 64 EVCs may be configured per 1 Gbps connection. For Basic Plus Service, a total of 7 EVCs may be configured per 10/100BaseT connection. A total of 63 EVCs may be configured per 1 Gbps connection. Should the customer request more than 64 EVCs on a Basic Service 1 Gbps connection, or more than 63 EVCs on a Basic Plus Service 1 Gbps, a technical review will need to be conducted to determine whether the network will support more EVCs. (T)

p. Customers will be allowed to move from the 10/100BaseT to the 1 Gigabit Ethernet interface where facilities and equipment permit, staying within or moving from the Basic or Basic Plus connection. Nonrecurring charges associated with the new 1 Gigabit Ethernet connection will apply as set forth in E. following. If the customer only wants to move from Basic to Basic Plus connection without changing the type of interface, the Miscellaneous Change Charge will apply as set forth in E. following. (T)

Continued

OTHER SERVICES

D13. ADVANCED SERVICES

13.1 OPT-E-MAN® (Cont'd)

B. SERVICE PROVISIONING (Cont'd)

1. Manner of Provisioning (Cont'd)

o. For Basic Service, a total of 8 Ethernet Virtual Connections (EVCs) may be configured per 10/100BaseT connection. A total of 64 EVCs may be configured per 1 Gbps connection. For Basic Plus Service, a total of 7 EVCs may be configured per 10/100BaseT connection. A total of 63 EVCs may be configured per 1 Gbps connection. Should the customer request more than 64 EVCs on a Basic Service 1 Gbps connection, or more than 63 EVCs on a Basic Plus Service 1 Gbps, a technical review will need to be conducted to determine whether the network will support more EVCs. (L)

p. Customers will be allowed to move from the 10/100BaseT to the 1 Gigabit Ethernet interface where facilities and equipment permit, staying within or moving from the Basic or Basic Plus connection. Nonrecurring charges associated with the new 1 Gigabit Ethernet connection will apply as set forth in E. following. If the customer only wants to move from Basic to Basic Plus connection without changing the type of interface, the Miscellaneous Change Charge will apply as set forth in E. following. (L)

q. The aggregate assigned Committed Information Rate (CIR) across all Ethernet Virtual Connections (EVCs) between two customer connections cannot exceed 600 Mbps per Basic or Basic Plus configuration.¹

The aggregate assigned Committed Information Rate (CIR) across all ICO trunk connections (EVCs) between any two customer connections utilizing a meet-point GigE ICO Trunk Arrangement between the Utility and an ILEC (ICO) cannot exceed 600 Mbps per Basic or Basic Plus connection.² (N)

NOTE 1: Applicable to new services installed after November 29, 2006.

NOTE 2: Applicable to new service installed after March 31, 2009. (N)

(L) Material formerly located on Sheet 2.1. (N)

Continued

OTHER SERVICES
D13. ADVANCED SERVICES

13.1 OPT-E-MAN® (Cont'd)

B. SERVICE PROVISIONING (Cont'd)

1. Manner of Provisioning (Cont'd)

q. The aggregate assigned Committed Information Rate (CIR) across all Ethernet Virtual Connections (EVCs) between two customer connections cannot exceed 600 Mbps per Basic or Basic Plus configuration.¹

(N)
|
(N)

NOTE 1: Applicable to new services installed after November 29, 2006. (N)

Continued

OTHER SERVICES
D13. ADVANCED SERVICES

- 13.1 OPT-E-MAN® (Cont'd)
B. SERVICE PROVISIONING (Cont'd)

2. Ordering Specifications and Provisioning

The customer must select an OPT-E-MAN service configuration as described in the following:

Basic The OPT-E-MAN Basic service configuration provides a switched, logical point-to-point or point-to-multipoint connection between customer locations using a physical connection to the network, and virtual connections through the OPT-E-MAN network.

Basic Plus The OPT-E-MAN Basic Plus service configuration provides a switched, logical point-to-point, point-to-multipoint or multipoint-to-multipoint connection between customer locations using a physical connection to the network, and virtual connections through the OPT-E-MAN network.

- a. OPT-E-MAN connection includes transport, port and interface to the Ethernet network, in which the customer orders one of the following connections:

- (1) 10/100BaseT (T)

10/100BaseT is an electrical handoff with a bandwidth limitation of 100 Mbps (T)

- (2) 1 Gbps Ethernet (1000BaseSX, 1000BaseLX/LH or 1000BaseZX)¹

1 Gbps Ethernet is a fiber handoff with a bandwidth limitation of 1 Gbps.

The customer must select a Committed Information Rate (CIR) and at least one (1) Ethernet Virtual Connection (EVC) to enable the service.

NOTE 1: Includes allowance for overhead within Utility's Ethernet network. If the customer orders 1 Gbps of CIR on a single port, the Utility reserves the right to use up to 10% of bandwidth for traffic management.

Material omitted now located on Sheet 3.1. (N)

Continued

OTHER SERVICES
D13. ADVANCED SERVICES

13.1 OPT-E-MAN® (Cont'd)

B. SERVICE PROVISIONING (Cont'd)

2. Ordering Specifications and Provisioning (Cont'd)

Grades of Service will be offered with each Committed Information Rate (CIR) and Ethernet Virtual Connection (EVC). Bronze and Silver Grades of Service will have an associated Service Level Agreement (SLA). Customer must select one of the following Grades of Service:

(L)
(C)

Best Effort: This Grade of Service supports non-critical data applications with more tolerance for delay and/or those that are lower in priority (i.e. LAN traffic). There are no service performance parameters associated with this Grade of Service.

(N)

(N)

Bronze: Intended for data applications with more tolerance for delay and/or those that are lower in priority, i.e., LAN traffic. The service parameters associated with this Grade of Service are Packet Delivery Rate (PDR) and Latency.

Silver: Intended for applications that require minimal loss and low latency variation. The service parameters associated with this Grade of Service are Packet Delivery Rate (PDR), Latency and Jitter.

(L)

(L) Material formerly located on Sheet 3.

(N)

Material omitted now located on Sheet 3.2.

(N)

Continued

OTHER SERVICES
D13. ADVANCED SERVICES

- 13.1 OPT-E-MAN® (Cont'd) (L)
B. SERVICE PROVISIONING (Cont'd)
2. Ordering Specifications and Provisioning (Cont'd)

An EVC is a logical point-to-point connection between two or more customer locations and goes from the customer demarcation point (Ethernet Interface) to the OPT-E-MAN network out to another customer demarcation point. Additional EVCs may be provisioned to establish additional virtual connections over the same physical connections. When additional EVCs are provisioned, the customer must designate the portion of the CIR bandwidth assigned to each EVC. For point-to-point and point-to-multipoint connections, EVCs can be set in 1 Mbps increments from 2 Mbps to 600 Mbps.¹ For multipoint-to-multipoint connections, EVCs can be set in 1 Mbps increments from 2 Mbps to 1 Gbps.¹ (C)

If the customer selects the Silver Grade of Service, the initial EVC will be prioritized as Silver. Additional EVCs can be prioritized as either Silver, Bronze or Best Effort. (C)

If the customer selects the Bronze Grade of Service, additional EVCs can be prioritized only as Bronze or Best Effort. (T)
(C)

If the customer selects the Best Effort Grade of Service, additional EVCs can only be prioritized as Best Effort. (N)
(N)

CIR is a statistical level of transmission or bandwidth that the network will provide. CIR is assigned to the port on the Network Terminating Equipment (NTE). If the customer wants more than 1 EVC on a port, then the CIR will need to be shared among the multiple EVCs. Rates and charges for CIRs are set forth in E. Current Rates and Charges, following. (L)

NOTE 1: Applicable to new services installed after November 29, 2006.

(L) Material formerly located on Sheet 3.1. (N)

Continued

OTHER SERVICES
D13. ADVANCED SERVICES

13.1 OPT-E-MAN® (Cont'd)
B. SERVICE PROVISIONING (Cont'd)

3. Limitations

OPT-E-MAN® is only available within the same Local Access Transport Areas (LATAs) and is subject to the availability and operational limitations of the Utility's equipment and associated facilities.

Regulations, rates and charges specified herein are in addition to other regulations, rates and charges as set forth in Schedule Cal.P.U.C. No. 175-T.

Limitations of liability for OPT-E-MAN® as set forth in Schedule Cal.P.U.C. No. 175-T, Section 2.1.2 and Schedule Cal.P.U.C. No. A2.1.14 are applicable.

Where facilities, equipment and/or operating conditions are not available, Special Construction charges as set forth in Schedule Cal.P.U.C. No. 175-T, Section 15. are applicable.

The Utility does not undertake to originate data, but offers the use of its service elements to customers for the purpose of transporting customer's originated data.

The responsibility of the Utility shall be limited to furnishing the OPT-E-MAN® network. Subject to this responsibility, the Utility shall not be responsible for the through transmission of signals generated by CPE or for the quality of, or defects in, such transmission or the rejection of signal by CPE.

The Utility will maintain and repair the service of which it furnishes and will provide the customer reasonable notification of service affecting activities that may occur in the normal operation of business.

Maintenance of service regulations and charges are set forth in Schedule Cal.P.U.C. No. 175-T, Section 13.3.1, Maintenance of Service, for customer reported trouble.

The Utility may request additional customer information as may be required to permit the Utility to maintain the OPT-E-MAN® network and to ensure that the service arrangement is in compliance with the regulations contained in this section.

(L)

The Utility shall not be responsible for error correction. Error correction is the responsibility of the customer's OPT-E-MAN® compatible CPE.

(L)

(L) Formerly located on Sheet 5.

(N)

Continued

OTHER SERVICES
D13. ADVANCED SERVICES

- 13.1 OPT-E-MAN® (Cont'd)
- B. SERVICE PROVISIONING (Cont'd)
- 3. Limitations (Cont'd)

OPT-E-MAN® service does not allow for oversubscription. The sum total of the bandwidth assigned to EVCS are mapped to a single port and cannot exceed the ordered CIR.

The Utility shall not be responsible for installation, operation, maintenance, or adapting OPT-E-MAN® to the technological requirements of any specific CPE.

The Utility shall not be responsible to the customer or user if changes in any of the equipment, operations, or procedures of the Utility used in provisioning of OPT-E-MAN® render any facilities provided by the customer or user obsolete; or require modification or alteration of such equipment or system; or otherwise affect its use or performance, provided the Utility has met all applicable information disclosure requirements otherwise required by law.

For Basic and Basic Plus point-to-point and point-to-multipoint service, the Utility will use controls to limit the amount of broadcast traffic to protect the OPT-E-MAN® network against broadcast storms. The maximum throughput of broadcast traffic will be set at 10 Mbps per customer port. Packets dropped by traffic controls will be excluded from SLA calculations. The Utility recommends that customers enable controls for broadcast traffic within the customer network.¹

(N)
|
(N)

For Basic Plus Multipoint to Multipoint service, the Utility will use controls to limit the amount of multicast and broadcast traffic to protect the OPT-E-MAN® network against traffic storms. The maximum throughput of multicast traffic will be set at 1 Mbps per customer port. The maximum throughput of broadcast traffic will be set at 200 packets per second per port.

The Utility recommends that customers enable controls for multicast, broadcast and unknown unicast traffic within the customer network(s).

4. Technical Specifications

Technical specifications are set forth in the following technical reference:

Network Equipment Design Requirements (SBC-TPT7620MP Issue 5, 10/03)
Ethernet Standards for SBC Local Exchange Companies (SBC-TP76412 Issue 2, 12/1/03)

This technical reference can be obtained from:

Apex Support Team
(734) 523-7348

NOTE 1: This provisioning requirement will only apply to new service installed after June 18, 2007.

Material omitted now located on Sheet 4.

(N)

Continued

OTHER SERVICES
D13. ADVANCED SERVICES

13.1 OPT-E-MAN® (Cont'd)
B. SERVICE PROVISIONING (Cont'd)

5. Allowance for Service Interruptions

- a. The Utility will administer its network to ensure the provision of acceptable service levels to all users of the Utility's OPT-E-MAN network. In case of an interruption of service, allowance for the period of interruption, if not due to the negligence of the customer, shall be as follows. No credit shall be allowed for an interruption of less than 10 seconds. If an interruption of service is more than 10 seconds, the customer shall be credited at the rate 10/8640 of the monthly charges for the service for each period of 5 minutes, or major fraction thereof, that the interruption continues. The credit allowance(s) for service interruptions shall not exceed 100% of the applicable monthly rates.

Service Level Agreements (SLAs) are offered with OPT-E-MAN for the Bronze and Silver Grades of Service and provide the customers with end to end performance backed by service credits if minimum quality standards are not met by the Utility. The following Service Level Agreement (SLA) will be supported for OPT-E-MAN Service for the Bronze and Silver Grades of Service:

(1) Network Availability

The Utility is committed to maintain Network Availability of 99.95% per month, including the local loop. This equates to less than 21.6 minutes of downtime per month (based on a 30-day month), excluding maintenance window and any exclusions as set forth in d.(2) following.

(a) Calculation

Network Availability is calculated as the percentage of time that the Optical network is capable of accepting and delivering customer data to the total time in the measurement period. The calculation for Network Availability for a given month is as follows:

$$\text{Network Availability} = \frac{(24 \text{ hours} \times \text{days in month} \times 60 \text{ minutes} \times \text{number of customer sites}) - \text{network outage time (measure in minutes)}}{(24 \text{ hours} \times \text{days in month} \times 60 \text{ minutes} \times \text{number of customer sites})}$$

As specified in the formula above, all ports included in a customer's network are utilized in calculating Network Availability.

(b) Reporting and Remedies

The customer is responsible for notifying the Utility within 45 days after the end of the month when Network Availability falls below the committed level and requesting a service credit. Upon verification by the Utility that the actual Network Availability for the service was less than the committed level, the customer will be provided a service credit equal to 10% of the monthly recurring charge for all affected ports.

Continued

OTHER SERVICES

(T)

D13. ADVANCED SERVICES

13.1 OPT-E-MAN® (Cont'd)

B. SERVICE PROVISIONING (Cont'd)

5. Allowance for Service Interruptions (Cont'd)

b. The following Service Level Agreements will be supported for the Bronze Grade of Service

(1) Packet Delivery Rate (PDR)

Packet Delivery Rate (PDR) is defined as the actual amount of useful and non-redundant information that is transmitted or processed from end-to-end across the network. The PDR is 99.5% of total traffic from source Network Terminating Equipment (NTE) to the destination NTE to which the customer ports are attached.

(a) Calculation

Packet delivery is measured by averaging sample measurements taken during a calendar month from NTE to NTE to which the customer ports are attached and calculations will be measured only when the OPT-E-MAN® network is available.

(b) Reporting and Remedies

The customer is responsible for notifying the Utility within 45 days after the end of the month when the PDR falls below the committed level and requesting a service credit. Upon notification by the customer that the actual PDR for the service was less than the committed level, the Utility has 30 days to correct the problem. If after 30 days, the PDR is still less than the committed level, the customer will be provided a service credit equal to 25% of the monthly recurring charge for all affected ports for the month in which the PDR falls below the committed level.

Continued

OTHER SERVICES

(T)

D13. ADVANCED SERVICES

13.1 OPT-E-MAN® (Cont'd)

B. SERVICE PROVISIONING (Cont'd)

5. Allowance for Service Interruptions (Cont'd)

- b. The following Service Level Agreements will be supported for the Bronze Grade of Service (Cont'd)

(2) Latency

The Utility is committed to maintain delay across the Utility's network of no more than 27 ms (54 ms roundtrip) one-way end-to-end within the Utility's network for packets 1500 bytes or less.

(a) Calculation

Latency is measured by averaging sample measurements taken during a calendar month between NTEs to which the customer ports are attached and calculations will be measured only when the OPT-E-MAN® Network is available.

(b) Reporting and Remedies

The customer is responsible for notifying the Utility within 45 days after the end of the month when Latency for a connection is above 27 ms one-way (54 ms roundtrip) and requesting a service credit. Upon notification by the customer that the actual delay for data was more than the committed level, the Utility has 30 days to correct the problem. If after 30 days, the delay is still more than the committed level, the customer will be provided a service credit equal to 25% of the monthly recurring charge for the affected ports in which the customer-specific delay was above the committed level.

Continued

OTHER SERVICES

(T)

D13. ADVANCED SERVICES

13.1 OPT-E-MAN® (Cont'd)

B. SERVICE PROVISIONING (Cont'd)

5. Allowance for Service Interruptions (Cont'd)

c. The following Service Level Agreements will be supported for the Silver Grade of Service

(1) Packet Delivery Rate (PDR)

Packet Delivery Rate (PDR) is defined as the actual amount of useful and non-redundant information that is transmitted or processed across the network. The PDR is 99.9% of total traffic from source Network Terminating Equipment (NTE) to the destination NTE to which the customer ports are attached.

(a) Calculation

Packet delivery is measured by averaging sample measurements taken during a calendar month from NTE to NTE to which the customer ports are attached and calculations will be measured only when the OPT-E-MAN® network is available.

(b) Reporting and Remedies

The customer is responsible for notifying the Utility within 45 days after the end of the month when the PDR falls below the committed level, and requesting a service credit. Upon notification by the customer that the actual PDR for the service was less than the committed level, the Utility has 30 days to correct the problem. If after 30 days, the PDR is still less than the committed level, the customer will be provided a service credit equal to 25% of the monthly recurring charge for all affected ports for the month in which the service parameters fall below the committed level.

Continued

OTHER SERVICES

(T)

D13. ADVANCED SERVICES

13.1 OPT-E-MAN® (Cont'd)

B. SERVICE PROVISIONING (Cont'd)

5. Allowance for Service Interruptions (Cont'd)

- c. The following Service Level Agreements will be supported for the Silver Grade of Service (Cont'd)

(2) Latency

The Utility is committed to maintain delay across the Utility's network at no more than 18 ms (36 ms roundtrip) one way end-to-end (including the local loop) within the Utility's network for packets 1500 bytes or less.

(a) Calculation

Latency is measured by averaging sample measurements taken during a calendar between NTE to which the customer ports are attached and calculations will be measured only when the OPT-E-MAN® network is available.

(b) Reporting and Remedies

The customer is responsible for notifying the Utility within 45 days after the end of the month when Latency for a connection is above 18 ms one-way (36 ms roundtrip) and requesting a service credit. Upon notification by the customer that the actual delay for data was greater than 18 ms one-way (36 ms roundtrip) the Utility has one month to correct the problem. If after one (1) month the delay is still greater than the committed level, the customer will be provided a service credit equal to 25% of the monthly recurring charge for the affected ports in which the customer-specific delay was greater than the committed level.

Continued

OTHER SERVICES

(T)

D13. ADVANCED SERVICES

13.1 OPT-E-MAN® (Cont'd)

B. SERVICE PROVISIONING (Cont'd)

5. Allowance for Service Interruptions (Cont'd)

- c. The following Service Level Agreements will be supported for the Silver Grade of Service (Cont'd)

(3) Jitter

The delay variance is the delta between a packet delay and the average packet delay of the sample of packets transmitted across the network. It is measured between two endpoints. The Utility is committed to maintain a jitter of less than 12 ms one way end-to-end (including the local loop) within the Utility's network.

(a) Calculation

Jitter is calculated by measuring the variance of packets delivered from one point to another. This measurement will be taken during the Utility's network busy hour and only when the OPT-E-MAN® network is available.

(b) Reporting and Remedies

The customer is responsible for notifying the Utility within 45 days after the end of the month when jitter for a connection is above 12 ms and requesting a service credit. Upon notification by the customer that the actual jitter was greater than 12 ms, the Utility has 30 days to correct the problem. If after 30 days the jitter is still greater than the committed level, the customer will be provided a service credit equal to 25% of the monthly recurring charge for the affected ports for the subsequent month in which the jitter was above the committed level.

Continued

OTHER SERVICES
D13. ADVANCED SERVICES

13.1 OPT-E-MAN® (Cont'd)

B. SERVICE PROVISIONING (Cont'd)

5. Allowance for Service Interruptions (Cont'd)

d. Service Level Agreement (SLA) Regulations and Exclusions

(1) Service Level Agreement (SLA) Regulations

(a) SLAs will be offered at no charge to all customers who subscribe to the Bronze or Silver Grades of Service.

(C)

(b) SLAs will apply to all connection types under the Bronze or Silver Grades of Service.

(C)

(c) SLA credits will not exceed full monthly charges for affected network elements.

(d) Packet Delivery Rate, Latency and Jitter calculations will be measured only when the OPT-E-MAN network is available.

Continued

OTHER SERVICES
D13. ADVANCED SERVICES

13.1 OPT-E-MAN® (Cont'd)

B. SERVICE PROVISIONING (Cont'd)

5. Allowance for Service Interruptions (Cont'd)

d. Service Level Agreement (SLA) Regulations and Exclusions (Cont'd)

(2) Service Level Agreement Exclusions

The Utility will be excused from providing any Service Level Agreement credits for the Bronze and Silver Grades of Service should any of the following conditions occur:

(C)

(a) Force majeure events such as, but not limited to, an earthquake, hurricane, flood, fire, storms, tornadoes, explosion, lightning, power surges or failure, fiber cuts, strikes or labor disputes; loss or damage resulting from any cause beyond the Utility's reasonable control such as acts of war, civil disturbances, acts of civil or military authorities or public enemy.

(b) All SLAs are end-to-end (hand-off at the customer demarcation to hand-off at the customer demarcation, including the local loop). The failure of any components beyond the local facility, including the Network Interface (NI), are excluded from SLA calculation.

(T)

(T)

(c) Data loss during the Utility's scheduled maintenance window.

(d) Data exceeding subscribed CIR.

(e) Failures attributed to facilities or equipment provided by customer or its contractors, equipment vendors, another local exchange carrier or inter-exchange carrier.

(f) Any customer Network Management is not included in SLA.

(g) Packets dropped by traffic controls are excluded from SLA calculations.

(T)

(h) Data exiting the network through the customer ports in a multipoint-to-multipoint configuration are excluded from SLA calculations to the extent that it exceeds the CIR for those ports.

Continued

OTHER SERVICES
D13. ADVANCED SERVICES

13.1 OPT-E-MAN® (Cont'd)

C. RATE REGULATIONS

This section identifies each rate element and discusses the rate application governing the rates and charges that apply to OPT-E-MAN.

Specific rates and charges for OPT-E-MAN are set forth in E. Current Rates and Charges, following.

Jurisdictional reporting requirements are set forth in Schedule Cal.P.U.C. No. 175-T, Section 2.3.14 Jurisdictional Report Requirements.

1. Rate Elements

The following identifies the rate elements offered, where facilities exist, for OPT-E-MAN.

a. Standard Connection

The Standard Connection rate element is assessed per interface at bandwidths of 100 Mbps (10/100BaseT) or 1 Gbps Ethernet. The OPT-E-MAN connection rate element includes the physical connection between the customer's demarcation and the core Ethernet network, and a port on the NTE. (T)

b. Ethernet Virtual Circuit (EVC)

EVC rate element is assessed in ranges of 2-1000 Mbps and is provided at no charge. EVCs can be assigned in 1 Mbps increments within each range. Additional EVCs may be ordered to establish additional virtual connections over the same physical connections. When additional EVCs are ordered, the customer must designate the portion of the CIR bandwidth assigned to each EVC. (C)

c. Committed Information Rate (CIR)

CIR rate element is defined as bandwidth, which is assessed per speed increments ranging from 2 Mbps to 1 Gbps. (C)

d. Additional Media Access Control (MAC) Addresses

MAC Addresses rate element is a data link layer protocol used for Layer 2 connectivity and is assessed per MAC address group 51-100. There is a limit of 100 MAC addresses total per port.

Continued

OTHER SERVICES
D13. ADVANCED SERVICES

13.1 OPT-E-MAN® (Cont'd)

C. RATE REGULATIONS (Cont'd)

1. Rate Elements (Cont'd)

The following identifies the rates elements offered, where facilities exist for OPT-E-MAN (Cont'd)

e. Service Order Change Charge

Service Order Change Charge is assessed for pending service order and is assessed per location:

- (1) Changes in physical and bandwidth configurations, such as increases in CIR, changes in the type of connection ordered or grade of service changes, i.e., Bronze to Silver.
- (2) Ethernet Virtual Circuit changes such as deleting or adding EVCs or changing the CIR associated with an EVC.
- (3) Port Changes include upgrading a port from 10/100BaseT to a 1 Gbps port or increasing the limit on the number of MAC Addresses that can be used with a port. (T)

f. Service Order Cancellation

If the customer cancels service prior to installation being completed, a Service Order Cancellation Charge (per port, per location) will apply, in addition to any unpaid Special Construction charge that the Utility has incurred.

g. Service Order Expedite

Service Order Expedite Charge is assessed per location when customer requests service to be installed sooner than the Utility/Customer agreed upon due date. Service can only be expedited if the Utility can accommodate the request.

h. Repeater

Repeater charge is assessed per location when customer requests OPT-E-MAN service from a serving wire center not equipped to provide OPT-E-MAN service and if the technical review indicates that service can be provided using a repeater from the customer's location to the Ethernet network.

i. Miscellaneous Change Charge

Miscellaneous Change Charge is assessed per location when customer requests changes to their existing OPT-E-MAN service:

- (1) Changes in physical and bandwidth configurations, such as increases in CIR, changes in the type of connection ordered or grade of service changes, i.e. Bronze to Silver.
- (2) Ethernet Virtual Circuit changes such as deleting or adding EVCs or changing the CIR associated with an EVC.
- (3) Port Changes include upgrading a port from 10/100BaseT to a 1 Gbps port or increasing the limit on the number of MAC Addresses that can be used with a port. (T)

Continued

OTHER SERVICES
D13. ADVANCED SERVICES

(T)

13.1 OPT-E-MAN® (Cont'd)

C. RATE REGULATIONS (Cont'd)

1. Rate Elements (Cont'd)

The following identifies the rates elements offered, where facilities exist for OPT-E-MAN®. (Cont'd)

j. The following diagram describes a standard service configuration for OPT-E-MAN®.

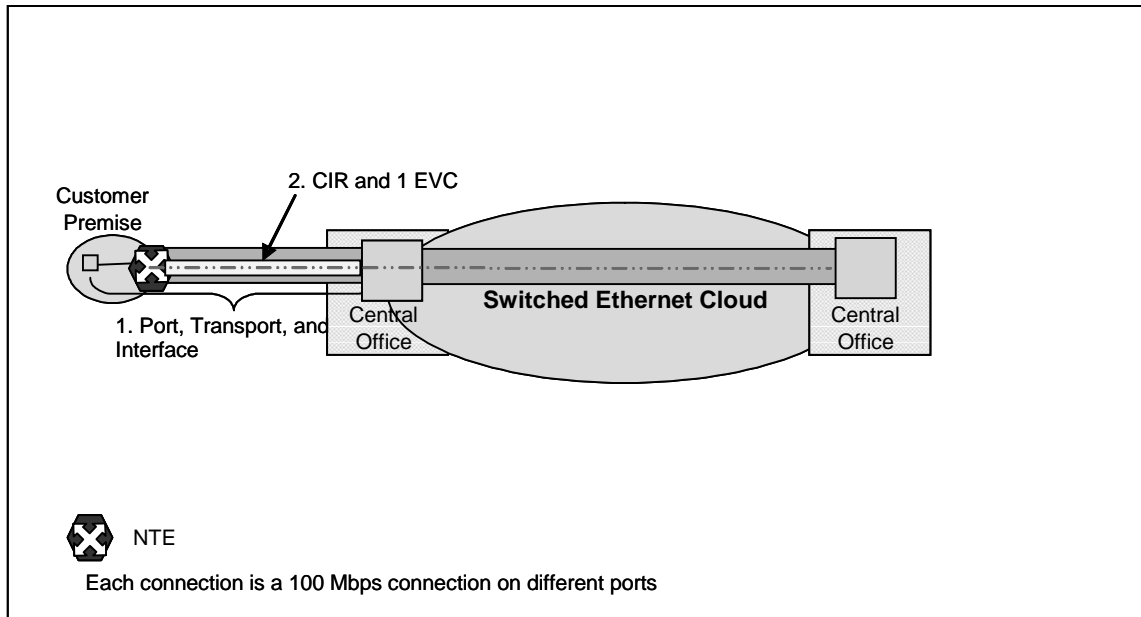

(1) Standard Connection

- Transport/Port/Interface

(2) Committed Information Rate (CIR) plus one (1) Ethernet Virtual Connection (EVC)

Continued

OTHER SERVICES

D13. ADVANCED SERVICES

13.1 OPT-E-MAN® (Cont'd)

C. RATE REGULATIONS (Cont'd)

1. Rate Elements (Cont'd)

The following identifies the rates elements offered, where facilities exist for OPT-E-MAN®. (Cont'd)

k. Meet-Point Billing Options

(N)

Meet-Point is available in two configurations:

Direct LEC Connection is provisioned using a standard OPT-E-MAN Basic or Basic Plus Connection and associated CIR, plus Mileage. The mileage is measured in airline miles from the OPT-E-MAN switch location to the ILEC (ICO) meet-point location.

GigE ICO Trunking Arrangement applies an ICO Trunk Connection Charge between the OPT-E-MAN switch location and the ICO meet-point location that is shared with the ILEC (ICO) Ethernet switch. The ICO Trunk Connection Charge is applied to each customer Ethernet Virtual Connection (EVC) that is transported on the GigE trunk backbone to the ICO meet-point. The ICO Trunk Mileage charge is applicable to each customer Ethernet Virtual Connection (EVC) transported across the GigE trunk when mileage exceeds 10 miles. Mileage is calculated from the OPT-E-MAN switch location to the ICO meet-point location.

(N)

Continued

OTHER SERVICES
D13. ADVANCED SERVICES

13.1 OPT-E-MAN® (Cont'd)

C. RATE REGULATIONS (Cont'd)

2. Term Pricing Plan

a. General

OPT-E-MAN® Term Pricing Plan (TPP) provides the customer with rate stabilization and discounted tariff rates. The OPT-E-MAN® TPP provides for a one, two, three or five year terms. Monthly extension will only be offered when a term contract has expired and the customer has not yet signed another term contract.

OPT-E-MAN® TPP monthly rates will be exempt from Utility initiated rate increases throughout the selected service period. Should the Utility increase its rates during the OPT-E-MAN® TPP service period, the customer would continue to pay the rates in effect at the time the customer elected to establish service under the OPT-E-MAN® TPP.

Decreases in OPT-E-MAN® TPP monthly recurring tariff rates will be passed on to customers who participate in an OPT-E-MAN® TPP.

Non-recurring charges will be waived for customers who subscribe to the 2, 3 or 5 year Term Payment Plan (TPP) for the Basic, Basic Plus Connection, Committed Information Rate (CIR), Additional MAC Addresses and Repeater rate elements.

(N)
|
(N)

b. Renewal of Term Pricing Plan

At the end of a Term Pricing Plan, the customer may renew with a written notice of intent to renew no later than 90 days prior to its expiration, for any TPP in effect without incurring new nonrecurring charges.

If the customer elects not to renew the TPP or does not notify the Utility of its intent to renew the TPP, the service will automatically be billed under the Monthly Extension rates in effect at the time the TPP expires until the customer cancels or renews the service with a new TPP term. Subsequently, customers under the Monthly Extension rates may convert their existing service to either a one, two, three, or five year TPP. The customer will not be assessed any associated nonrecurring charges as long as the physical serving arrangement does not change.

Monthly Extensions are not available to new service.

Continued

OTHER SERVICES
D13. ADVANCED SERVICES

13.1 OPT-E-MAN® (Cont'd)

C. RATE REGULATIONS (Cont'd)

2. Term Pricing Plan (Cont'd)

c. Change of Term Pricing Plan

At any time, a customer may change an existing TPP to a new TPP only when the new TPP payment period is longer than the remaining period currently in effect, without any Termination Liability Charges or nonrecurring charges applying as long as all other aspects of the service and facilities remain unchanged. The new TPP begins on the service order completion date and is treated as a new TPP period.

d. Service Available Under OPT-E-MAN TPP

A customer may elect to participate in the OPT-E-MAN TPP for the OPT-E-MAN Basic Connection and Repeater rate elements only.

e. Terms and Conditions

Customers must specify the length of the service period at the time the OPT-E-MAN is established.

Customers may upgrade their usage (CIR) to a higher speed without incurring termination charges, depending on facilities used. The Utility will determine whether such an upgrade is permissible based on the type of facilities currently used to provide the service.

(T)
(N)
|
(N)

Customers may upgrade their Grade of Service without incurring Termination Charges provided the upgrade does not include any reduction in the customer's existing CIR.

(D)

Customers may move their existing service to a new location without incurring termination charges provided all of the following conditions are met:

- (1) The customer maintains the existing TPP at the new location or establishes a new TPP equal to or greater than at the old location;
- (2) During the Term Payment Plan, a customer may move OPT-E-MAN location to another premises in the same LATA and keep the Term Plan in force without assessment of Early Termination Liability, provided no lapse in billing occurs;
- (3) The customer's request for disconnect at the existing location and the request for service at the new location are received at the same time;

Continued

OTHER SERVICES
D13. ADVANCED SERVICES

(T)

- 13.1 OPT-E-MAN® (Cont'd)
C. RATE REGULATIONS (Cont'd)
2. Term Pricing Plan (Cont'd)
e. Terms and Conditions (Cont'd)

Customers may move their existing service to a new location without incurring termination charges provided all of the following conditions are met: (Cont'd)

- (4) The customer's disconnect order for the existing service references the new connect order for the new service;
- (5) Moves of one location to a premise in a different serving office may result in a change in the monthly charges. Nonrecurring charges, as appropriate, are applicable as set forth in E. Rates and Charges, following. (T)
- (6) If the customer moves more than one location of the service concurrently the customer will be liable for Termination Liability charges as this is considered a complete disconnect of the service.

f. Termination Charges

In addition to any special construction liabilities, as set forth in Schedule Cal.P.U.C. 175-T, Section 15., customer termination liability for cancellation of OPT-E-MAN® TPP shall be equal to: (T)

- (1) Any unpaid Special Construction or nonrecurring charges (excluding any waived charges); plus
- (2) Fifty percent (50%) of all recurring charges for the remaining months of the customer's term which the customer agrees to pay within 30 days. (T)
- (3) The termination charge is calculated as follows:

(Monthly Recurring Rate) x (Months remaining in TPP term) x (Termination Billing Period Percentage) (T)

Example: A customer with a \$1,800.00 monthly rate terminates service with 10 months remaining in a 3 year TPP term. (T)

The termination liability charges would be calculated as follows: (\$1800.00) x (10) x (.50) = \$9,000.00 (T)

Continued

OTHER SERVICES

(T)

D13. ADVANCED SERVICES

13.1 OPT-E-MAN® (Cont'd)
D. RESERVED

(T)

(D)

(D)

(D)

(D)

Continued

OTHER SERVICES

(T)

D13. ADVANCED SERVICES

13.1 OPT-E-MAN® (Cont'd)
D. RESERVED (Cont'd)

(T)

(D)

(D)

Continued

OTHER SERVICES

(T)

D13. ADVANCED SERVICES

13.1 OPT-E-MAN® (Cont'd)
D. RESERVED (Cont'd)

(T)

(D)

(D)

Continued

OTHER SERVICES
 D13. ADVANCED SERVICES

13.1 OPT-E-MAN®(Cont'd)

E. CURRENT RATES AND CHARGES

| | <u>Nonrecurring Charges³</u> | <u>12 Months</u> | <u>24 Months</u> | <u>36 Months</u> | <u>60 Months</u> | <u>Monthly Extension</u> | | |
|--|---|----------------------|----------------------|----------------------|----------------------|------------------------------|-----|-----|
| Standard Connection ¹ Per Location | | | | | | | | |
| <u>Basic Service</u> | | | | | | | | |
| 10/100BaseT | \$1925.00 | \$ 780.00 | \$ 750.00 | \$ 650.00 | \$ 575.00 | \$ 925.00 | (T) | |
| 1 Gbps | 2100.00 | 1200.00 | 1150.00 | 1000.00 | 850.00 | 1400.00 | | |
| <u>Basic Plus Service</u> | | | | | | | | |
| 10/100BaseT | \$1925.00 | \$ 780.00 | \$ 750.00 | \$ 650.00 | \$ 575.00 | \$ 925.00 | (T) | |
| 1 Gbps | 2100.00 | 1200.00 | 1150.00 | 1000.00 | 850.00 | 1400.00 | | |
| <u>Grade of Service Monthly Charges</u> | | | | | | | | |
| | <u>Nonrecurring Charges</u> | <u>Best Effort</u> | <u>Bronze</u> | <u>Silver</u> | | | | (N) |
| Ethernet Virtual Connection (EVC) ² - per connection | | | | | | | | |
| 2-1000 Mbps | \$0.00 | \$0.00 | \$0.00 | \$0.00 | | | | (N) |

NOTE 1: Standard Connection rates include the Interface, Port and Transport rate element.
 NOTE 2: Ethernet Virtual Connections are required for provisioning purposes only and can be assigned in 1 Mbps increments.
 NOTE 3: Non-recurring charges waived for customers who subscribe to the 24, 36 or 60 month Term Payment Plan (TPP).

Continued

OTHER SERVICES
 D13. ADVANCED SERVICES

13.1 OPT-E-MAN® (Cont'd)
 E. CURRENT RATES AND CHARGES (Cont'd)

| Committed Information Rate (CIR) | Nonrecurring Charge ¹ | Grade of Service Monthly Charge | | | (N) | |
|--|-------------------------------------|------------------------------------|----------|----------|-----|-----|
| | | Best Effort | Bronze | Silver | | |
| 2 Mbps | \$75.00 | \$255.00 | \$300.00 | \$500.00 | (N) | |
| 4 Mbps | 75.00 | 295.00 | 350.00 | 550.00 | | |
| 5 Mbps | 75.00 | N/A | 450.00 | 650.00 | | |
| 8 Mbps | 75.00 | 465.00 | 550.00 | 750.00 | | |
| 10 Mbps | 75.00 | N/A | 650.00 | 850.00 | | |
| 20 Mbps | 75.00 | N/A | 900.00 | 1,100.00 | | |
| 50 Mbps | 75.00 | N/A | 1,025.00 | 1,225.00 | | |
| 100 Mbps | 75.00 | N/A | 1,200.00 | 1,400.00 | | |
| 150 Mbps | 75.00 | N/A | 1,375.00 | 1,775.00 | | |
| 250 Mbps | 75.00 | N/A | 1,575.00 | 1,975.00 | | |
| 500 Mbps | 75.00 | N/A | 1,900.00 | 2,300.00 | | |
| 600 Mbps | 75.00 | N/A | 2,225.00 | 2,625.00 | | |
| 1000 Mbps | 75.00 | N/A | 2,575.00 | 2,975.00 | | (N) |

N/A - Not Available

(N)

NOTE 1: Non-recurring charges waived for customers who subscribe to the 24,
 36 or 60 month Term Payment Plan (TPP).

Continued

OTHER SERVICES
 D13. ADVANCED SERVICES

13.1 OPT-E-MAN@(Cont'd)
 E. CURRENT RATES AND CHARGES (Cont'd)

| | <u>Nonrecurring Charge</u> | <u>Monthly Charge</u> | |
|---|---|------------------------------|----------------------|
| Additional Mac Addresses ¹ - 51-100 | \$70.00 | \$5.00 | (N) |
| Service Order Change Charge | 75.00 | NA | |
| Miscellaneous Change Charge | 50.00 | NA | |
| Service Order Cancellation Charge | 200.00 | NA | |
| Order Expedite | 300.00 | NA | |
| | <u>Nonrecurring Charges¹</u> | <u>12 Months</u> | <u>24 Months</u> |
| | | <u>36 Months</u> | <u>60 Months</u> |
| | | <u>Monthly Extension</u> | (N) |
| Repeater | \$250.00 | \$400.00 | \$375.00 |
| | | \$325.00 | \$300.00 |
| | | | \$475.00 |

NOTE 1: Non-recurring charges waived for customers who subscribe to the 24, 36 or 60 month Term Payment Plan (TPP). (N)
 (N)

Continued

OTHER SERVICES

D13. ADVANCED SERVICES

13.1 OPT-E-MAN@(Cont'd)

E. CURRENT RATES AND CHARGES (Cont'd)

| | | | | <u>Nonrecurring Charge</u> | <u>Monthly Price</u> | (N) |
|--------------------------------------|--|----------------------|----------------------|--------------------------------|--------------------------|------------------------------|
| Meet-Point Billing Options | | | | | | |
| - Direct LEC Connection, Mileage | | | | | | |
| | | | | \$1,200.00 | \$500.00 | |
| | | | | 1,200.00 | 1,000.00 | |
| | | | | 1,200.00 | 1,500.00 | |
| | | | | 1,200.00 | 2,500.00 | |
| | <u>Nonrecurring Charge¹</u> | <u>12 Months</u> | <u>24 Months</u> | <u>36 Months</u> | <u>60 Months</u> | <u>Monthly Extension</u> |
| - GigE ICO Trunking Arrangement | | | | | | |
| ICO Trunk Connection Charge, per EVC | | | | | | |
| 2 Mbps | \$300.00 | \$340.00 | \$290.00 | \$250.00 | \$220.00 | \$400.00 |
| 4 Mbps | 345.00 | 380.00 | 330.00 | 285.00 | 250.00 | 440.00 |
| 5 Mbps | 400.00 | 430.00 | 370.00 | 315.00 | 270.00 | 500.00 |
| 8 Mbps | 460.00 | 490.00 | 420.00 | 360.00 | 310.00 | 570.00 |
| 10 Mbps | 525.00 | 570.00 | 490.00 | 420.00 | 360.00 | 660.00 |
| 20 Mbps | 600.00 | 670.00 | 580.00 | 504.00 | 430.00 | 780.00 |
| 50 Mbps | 700.00 | 840.00 | 730.00 | 630.00 | 540.00 | 970.00 |
| 100 Mbps | 800.00 | 1,120.00 | 970.00 | 840.00 | 720.00 | 1,290.00 |
| 150 Mbps | 925.00 | 1,670.00 | 1,450.00 | 1,260.00 | 1,080.00 | 1,930.00 |
| 250 Mbps | 1,100.00 | 2,160.00 | 1,870.00 | 1,620.00 | 1,380.00 | 2,490.00 |
| 500 Mbps | 1,100.00 | 4,640.00 | 4,030.00 | 3,500.00 | 2,980.00 | 5,340.00 |
| 600 Mbps | 1,100.00 | 5,560.00 | 4,830.00 | 4,200.00 | 3,570.00 | 6,400.00 |
| 1 Gbps | 1,100.00 | 6,390.00 | 5,500.00 | 4,830.00 | 4,100.00 | 7,360.00 |

NOTE 1: Nonrecurring charges will be waived for those customers selecting the 24, 36 or 60 month Term Pricing Plan (TPP) period for new service.

(N)

Continued

OTHER SERVICES

D13. ADVANCED SERVICES

13.1 OPT-E-MAN@(Cont'd)

E. CURRENT RATES AND CHARGES (Cont'd)

| | <u>Monthly Charge</u> | (N) |
|--|---------------------------|-----|
| Meet-Point Billing Options (cont'd) | | |
| - GigE ICO Trunking Arrangement (cont'd) | | |
| ICO Trunk Mileage, per EVC | | |
| Above 0 and inclusive of 10 miles | N/A | |
| Above 10 and inclusive of 25 miles | | |
| 2 Mbps to 20 Mbps | \$170.00 | |
| 50 Mbps to 150 Mbps | 375.00 | |
| 250 Mbps to 1 Gbps | 1,500.00 | |
| Above 25 and inclusive of 35 miles | | |
| 2 Mbps to 20 Mbps | 270.00 | |
| 50 Mbps to 150 Mbps | 675.00 | |
| 250 Mbps to 1 Gbps | 1,750.00 | |
| Above 35 and inclusive of 50 miles | | |
| 2 Mbps to 20 Mbps | 410.00 | |
| 50 Mbps to 150 Mbps | 1,100.00 | |
| 250 Mbps to 1 Gbps | 2,000.00 | (N) |

Continued

OTHER SERVICES

(T)

D13. ADVANCED SERVICES

13.2 CUSTOMIZED SWITCHED METRO ETHERNET (CSME) SERVICE

A. GENERAL DESCRIPTION

1. Service Description

Customized Switched Ethernet (CSME) Service is an advanced service offering networking capabilities utilizing Optical Ethernet. CSME provides an integrated service offering consisting of fiber transport connected to an Ethernet device capable of switching and routing. Customers will connect to the service using a router, bridge or switch. CSME Service provides bandwidths of 10 Mbps, 100 Mbps or 1 Gbps.

CSME allows customers to connect multiple locations within a Metropolitan Area Network (MAN) as if they were segments on the same LAN.

CSME Service provides the customer the capability to connect to the Utility's Ethernet network, where facilities exist, via one of the following standard network interfaces:

10/100 Mbps Base T

1 Gbps Ethernet (1000 Base SX, 1000 Base LX/LH or 1000 Base ZX)¹

CSME Service includes the transport from the customer's premises to the Ethernet network, a port on the Ethernet network and the bandwidth that will be used across the network.

CSME Service provides the ability to segregate customer traffic by the use of Ethernet Virtual Connections (EVC) at an additional charge.

Network Terminating Equipment (NTE) will be placed at the customer's premises as part of the CSME Service. The NTE functions as a switching and routing device

A detailed description of the rate elements and how they applied can be found in C. Rate Regulations, following.

Specifications for ordering CSME Service rate elements are identified in B.2. Ordering Specifications and Provisioning, following.

NOTE 1: Includes allowances for overhead within the Utility's Ethernet Network. If a customer orders 1 Gbps of bandwidth on a single port, the Utility reserves the right to use up to 10% of bandwidth for traffic management.

Continued

OTHER SERVICES

(T)

D13. ADVANCED SERVICES

13.2 CUSTOMIZED SWITCHED METRO ETHERNET (CSME) SERVICE (Cont'd)

B. SERVICE PROVISIONING

1. Manner of Provisioning

- a. Provisioning of this service is subject to the availability and operational limitations of the Utility's equipment and associated facilities. Where facilities and/or operating conditions are not available, Special Construction charges as set forth in Schedule Cal.P.U.C. No. 175-T, Section 15. may apply. (T)
- b. Access into the Utility's network must conform to industry standards and specifications as set forth in the Utility's technical publication.
- c. The Utility will provision up to and including the Network Terminating Equipment (NTE). The Utility will place NTE at either a Multi-Tenant Unit (MTU) or Single Tenant Unit (STU). MTU NTEs are shared among multiple customers. The placement of the NTE shall be located in a manner consistent with federal and state regulatory requirements. This location will be at each customer's premises, unless specified otherwise and agreed to by the Utility.
- d. NTEs installed by the Utility on the customer's premises shall remain the property of the Utility. The customer or user may not rearrange, disconnect, remove, attempt to repair, remote test or interface with any network equipment installed by the Utility without prior written consent of the Utility.
- e. The customer shall be responsible for obtaining permission for the Utility's agents or employees to enter the customer's premises at a mutually agreed upon time for the purpose of installing, inspecting, repairing, or removing (upon termination of the service) the equipment of the Utility.
- f. The operating characteristics of customer provided equipment (CPE) used in connection with CSME must not interfere with the Utility's CSME network. CPE must not:
 - (1) Endanger the safety of the Utility's employees or the public;
 - (2) Damage, harm, require change in or alteration of the equipment or other services of the Utility; or
 - (3) Interfere with the proper operation of the Utility's equipment.

Continued

OTHER SERVICES

D13. ADVANCED SERVICES

13.2 CUSTOMIZED SWITCHED METRO ETHERNET (CSME) SERVICE (Cont'd)

B. SERVICE PROVISIONING (Cont'd)

1. Manner of Provisioning (Cont'd)

g. Upon notice from the Utility that the CPE is causing, or is likely to cause, such hazard or interference, the customer shall take such steps as necessary to remove or prevent such hazard or interference.

h. CSME Service supports full duplex communication.

i. If a customer connects to the CSME network using a bridge or switch for Layer 2 connectivity, only 150 Media Access Control (MAC) addresses can be used per Layer 2 device, per port. Any additional addresses will be assessed additional charges, with a limit of 200 MAC addresses total per port as set forth in E. Rates and Charges, following.

j. Repeater technology may be used for customers requesting CSME service from a serving wire center not equipped to provide CSME service or if customers are outside the technical limits of an Ethernet equipped Central Office. A technical review will be necessary to determine if service can be provided. Only one repeater can be used on a connection between the Ethernet equipped Central Office and the customer premises. A repeater will incur additional charges as set forth in E. following.

k. CSME Service may be available in a meet-point billing arrangement (C)
involving another Incumbent Local Exchange Carrier (ILEC) (C)
(sometimes also referred to as an Independent Company or ICO), where (N)
suitable facilities exist and where appropriate procedures for such
arrangements have been put in place between the Company and the other
ILEC. When the Company and another ILEC jointly provision CSME Service
with the other ILEC's service, the ILEC involved shall bill the customer
at that ILEC's applicable rates for their portion of the service located
in their operating territory. Ordering and provisioning procedures may
vary, and therefore Meet-Point rate elements and charges may not be
applicable, when the other ILEC involved in the Meet-Point arrangement is
an AT&T ILEC. (N)

l. A Letter of Authorization will need to be established if customers want to purchase a logical connection via an EVC to another provider (IXC, ISP or other) in order to ensure security and accuracy in the connection.

Material omitted now located on Sheet 20.1.

(N)

Continued

OTHER SERVICES

(T)

D13. ADVANCED SERVICES

13.2 CUSTOMIZED SWITCHED METRO ETHERNET (CSME) SERVICE (Cont'd)

B. SERVICE PROVISIONING (Cont'd)

1. Manner of Provisioning (Cont'd)

- g. Upon notice from the Utility that the CPE is causing, or is likely to cause, such hazard or interference, the customer shall take such steps as necessary to remove or prevent such hazard or interference.
- h. CSME Service supports full duplex communication.
- i. If a customer connects to the CSME network using a bridge or switch for Layer 2 connectivity, only 150 Media Access Control (MAC) addresses can be used per Layer 2 device, per port. Any additional addresses will be assessed additional charges, with a limit of 200 MAC addresses total per port as set forth in E. Rates and Charges, following.
- j. Repeater technology may be used for customers requesting CSME service from a serving wire center not equipped to provide CSME service or if customers are outside the technical limits of an Ethernet equipped Central Office. A technical review will be necessary to determine if service can be provided. Only one repeater can be used on a connection between the Ethernet equipped Central Office and the customer premises. A repeater will incur additional charges as set forth in E. following.
- k. CSME Service is not available in a meet-point billing arrangement involving other Carriers.
- l. A Letter of Authorization will need to be established if customers want to purchase a logical connection via an EVC to another provider (IXC, ISP or other) in order to ensure security and accuracy in the connection.
- m. A total of 8 Ethernet Virtual Connections (EVCs) may be configured per 10/100 Base T port should the customer wish to segregate traffic. A total of 64 EVCs may be configured per 1 Gbps port. Should the customer request more than 64 EVCs on 1 Gbps port, a technical review will need to be conducted to determine whether the network will support more than 64 EVCs.
- n. If the customer orders 10 Mbps or 100 Mbps bandwidth connection, the Utility will only provision the service using the 10/100 Base T Connection.
- o. The Utility will use controls to limit the amount of multicast and broadcast traffic to protect the CSME network against traffic storms. The maximum throughput of multicast traffic will be set at 1 Mbps per customer port, while the maximum throughput of broadcast traffic will be set at 200 packets per second per port. The Utility recommends that customers enable controls for multicast, broadcast and unknown unicast traffic within the customer network(s).

Continued

OTHER SERVICES

D13. ADVANCED SERVICES

13.2 CUSTOMIZED SWITCHED METRO ETHERNET (CSME) SERVICE (Cont'd)

B. SERVICE PROVISIONING (Cont'd)

1. Manner of Provisioning (Cont'd)

- m. A total of 8 Ethernet Virtual Connections (EVCs) may be configured per 10/100 Base T port should the customer wish to segregate traffic. A total of 64 EVCs may be configured per 1 Gbps port. Should the customer request more than 64 EVCs on 1 Gbps port, a technical review will need to be conducted to determine whether the network will support more than 64 EVCs. (L)
- n. If the customer orders 10 Mbps or 100 Mbps bandwidth connection, the Utility will only provision the service using the 10/100 Base T Connection.
- o. The Utility will use controls to limit the amount of multicast and broadcast traffic to protect the CSME network against traffic storms. The maximum throughput of multicast traffic will be set at 1 Mbps per customer port, while the maximum throughput of broadcast traffic will be set at 200 packets per second per port. The Utility recommends that customers enable controls for multicast, broadcast and unknown unicast traffic within the customer network(s). (L)

(L) Material formerly located on Sheet 20.

(N)

Continued

OTHER SERVICES

(T)

D13. ADVANCED SERVICES

13.2 CUSTOMIZED SWITCHED METRO ETHERNET (CSME) SERVICE (Cont'd)

B. SERVICE PROVISIONING (Cont'd)

2. Ordering Specifications and Provisioning

- a. The customer must order CSME Service via one of the following network interfaces as described in the following:

(1) 10/100 Base T

10/100 Base T is an electrical handoff with a bandwidth limitation of 100 Mbps

(2) 1 Gbps Ethernet (1000 Base SX, 1000 Base LX/LH or 1000 Base ZX)¹

1 Gbps is a fiber handoff with a bandwidth limitation of 1 Gbps¹

- b. CSME standard features includes the usage, transport, port, and interface to the Ethernet network. In addition, the customer must select one of the following bandwidth usage:

- (1) 10 Mbps,
(2) 100 Mbps or
(3) 1 Gbps.

CSME also provides the customer with an option to purchase additional (subsequent) bandwidth. Subsequent bandwidth can be ordered either in 10 Mbps or 100 Mbps connection.

If the customer requests the ability to segregate traffic, Ethernet Virtual Connection (EVC) may be ordered at an additional charge. EVC is a logical point to point connection between two or more customer locations and goes from the customer demarcation point (Ethernet Interface) to the network out to another customer demarcation point. Additional EVCs may be ordered to establish additional virtual connections over the same physical connection. When EVCs are ordered, the customer must designate the amount of bandwidth assigned to each EVC.

NOTE 1: Includes allowances for overhead within the Utility's Ethernet Network. If a customer orders 1 Gbps of bandwidth on a single port, the Utility reserves the right to use up to 10% of the bandwidth for traffic management.

Continued

OTHER SERVICES

(T)

D13. ADVANCED SERVICES

13.2 CUSTOMIZED SWITCHED METRO ETHERNET (CSME) SERVICE (Cont'd)

B. SERVICE PROVISIONING (Cont'd)

3. Limitations

CSME is only available within the same Local Access Transport Areas (LATAs) and is subject to the availability and operational limitations of the Utility's equipment and associated facilities.

Regulations, rates and charges specified herein are in addition to other regulations, rates and charges as set forth in Schedule Cal.P.U.C. No. 175-T.

(T)

Limitations of liability for OPT-E-MANSM as set forth in Schedule Cal.P.U.C. No. 175-T, Section 2.1.2 and Schedule Cal.P.U.C. No. A2.1.14 are applicable.

Where facilities, equipment and/or operating conditions are not available, Special Construction charges as set forth in Schedule Cal.P.U.C. No. 175-T, Section 15. are applicable.

(T)

The Utility does not undertake to originate data, but offers the use of its service elements to customers for the purpose of transporting customer's originated data.

The responsibility of the Utility shall be limited to furnishing the Ethernet network. Subject to this responsibility, the Utility shall not be responsible for the through transmission of signals generated by CPE or for the quality of, or defects in, such transmission or the rejection of signal by CPE.

The Utility will maintain and repair the service it furnishes and will provide the customer reasonable notification of service affecting activities that may occur in the normal operation of business.

Maintenance of service regulations and charges are set forth in Schedule Cal.P.U.C. No. 175-T, Section 13.3.1, Maintenance of Service, for customer reported trouble.

The Utility may request additional customer information as may be required to permit the Utility to maintain the CSME network and to ensure that the service arrangement is in compliance with the regulations contained in this section.

Continued

OTHER SERVICES

(T)

D13. ADVANCED SERVICES

13.2 CUSTOMIZED SWITCHED METRO ETHERNET (CSME) SERVICE (Cont'd)

B. SERVICE PROVISIONING (Cont'd)

3. Limitations (Cont'd)

The Utility shall not be responsible for error correction. Error correction is the responsibility of the customer's CSME compatible CPE.

The Utility shall not be responsible for installation, operating, maintaining, or adapting CSME to the technological requirements of any specific CPE.

The Utility shall not be responsible to the customer or user if changes in any of the equipment, operations, or procedures of the Utility used in provisioning of CSME render any facilities provided by the customer or user obsolete; or require modification or alteration of such equipment or system; or otherwise affect its use or performance, provided the Utility has met all applicable information disclosure requirements otherwise required by law.

Ethernet Virtual Connections (EVCs) do not provide traffic prioritization.

Service Level Agreements (SLAs) are not offered with CSME Service, however, Credit Allowances are applicable as set forth in 5. following. (T)

4. Technical Specifications

Technical specifications are set forth in the following technical reference:

Network Equipment Design Requirements (SBC TP-6200MP Issue 5, 10/03)
Ethernet Standards for SBC Local Exchange Companies (SBC TP-76412 Issue 2, 12/1/03)

This technical reference can be obtained from:

APEX Support Team
(734) 523-7348

Continued

OTHER SERVICES

(T)

D13. ADVANCED SERVICES

13.2 CUSTOMIZED SWITCHED METRO ETHERNET (CSME) SERVICE (Cont'd)

B. SERVICE PROVISIONING (Cont'd)

5. Allowance for Service Interruptions

The Utility will administer its network to ensure the provision of acceptable service levels to all users of the Utility's CSME network. In case of an interruption of service, allowance for the period of interruption, if not due to the negligence of the customer, shall be as follows. No credit shall be allowed for an interruption of less than 10 seconds. If an interruption of service is more than 10 seconds, the customer shall be credited at the rate 10/8640 of the monthly charges for the service for each period of 5 minutes, or major fraction thereof, that the interruption continues. The credit allowance(s) for service interruptions shall not exceed 100% of the applicable monthly rates.

The Utility will be excluded from providing a Credit Allowance should any of the following conditions occur:

- a. Force majeure events such as, but not limited to an earthquake, hurricane, flood, fire, storms, tornadoes, explosion, lightning, power surges or failure, fiber cuts, strikes or labor disputes. Loss or damage resulting from any cause beyond the Utility's reasonable control such as acts of war, civil disturbances, acts of civil or military authorities or public enemy.
- b. Data loss during the Utility's scheduled maintenance window.
- c. Failures attributed to facilities or equipment provided by customer or its contractors, equipment vendors, another local exchange carrier or inter-exchange carrier.

(T)

Continued

OTHER SERVICES

(T)

D13. ADVANCED SERVICES

13.2 CUSTOMIZED SWITCHED METRO ETHERNET (CSME) SERVICE (Cont'd)

C. RATE REGULATIONS

This section identifies each rate element and discusses the rate application governing the rates and charges that apply to CSME.

Specific rates and charges for CSME are set forth in E. Rates and Charges, following.

Jurisdictional reporting requirements are set forth in Schedule Cal.P.U.C. No. 175-T, Section 2.3.14 Jurisdictional Report Requirements.

1. Rate Elements

The following identifies the rate elements offered, where facilities exist, for CSME.

a. Standard Features

Standard Feature rate element is assessed per interface at bandwidth of 10 Mbps, 100 Mbps or 1 Gbps. The CSME standard feature rate element include the physical connection between the customer's demarcation and the core Ethernet network, and a port on the NTE.

b. Ethernet Virtual Connection (EVC)

EVC rate element is assessed in 1 Mbps increments ranging from 5 Mbps to 1 Gbps.

c. Additional Media Access Control (MAC) Addresses

MAC Addresses rate element is a data link layer protocol used for Layer 2 connectivity and is assessed per MAC address up to 150 per port at no additional charge. Should the customer require additional MAC addresses over the first 150, customers will be assessed an additional charge per block of 150-200 addresses with a limit of 200 MAC addresses per port as specified in E. Rates and Charges, following.

Continued

OTHER SERVICES

(T)

D13. ADVANCED SERVICES

13.2 CUSTOMIZED SWITCHED METRO ETHERNET (CSME) SERVICE (Cont'd)

C. RATE REGULATIONS (Cont'd)

1. Rate Elements (Cont'd)

The following identifies the rates elements offered, where facilities exist for CSME. (Cont'd)

d. Service Order Change Charge

Service Order Change Charge is assessed for pending service order and is assessed per location:

- (1) Changes in physical and usage configurations, such as increases in bandwidth usage or changes in the type of connection ordered. (T)
- (2) Ethernet Virtual Connection changes
- (3) Port Changes include upgrading a port from 10/100 Base T to a 1 Gbps port or increasing the limit on the number of MAC Addresses that can be used with a port.

e. Service Order Cancellation

If the customer cancels service prior to installation being completed, a Service Order Cancellation Charge (per port, per location) will apply, in addition to any unpaid Special Construction charges that the Utility has incurred.

f. Service Order Expedite

Service Order Expedite Charge is assessed per location when customer requests service to be installed sooner than the Utility/Customer agreed upon due date. Service can only be expedited if the Utility can accommodate the request.

g. Repeater

Repeater charge is assessed per location when customer requests CSME service from a serving wire center not equipped to provide CSME service and if the technical review indicates that service can be provided using a repeater from the customer's location to the Ethernet network.

h. Miscellaneous Change Charge

Miscellaneous Change Charge is assessed per location when customer requests changes to their existing CSME service:

- (1) Changes in physical and usage configurations, such as increases in bandwidth usage or changes in the type of connection ordered. (T)
- (2) Ethernet Virtual Connection changes
- (3) Port Changes include upgrading a port from 10/100 Base T to a 1 Gbps port or increasing the limit on the number of MAC Addresses that can be used with a port.

Continued

OTHER SERVICES

D13. ADVANCED SERVICES

13.2 CUSTOMIZED SWITCHED METRO ETHERNET (CSME) SERVICE (Cont'd)

C. RATE REGULATIONS (Cont'd)

1. Rate Elements (Cont'd)

i. Meet-Point Billing Options

Meet-Point is available in two configurations:

Direct LEC Connection is provisioned using a standard CSME Connection, plus Mileage. The mileage is measured in airline miles from the CSME switch location to the ILEC (ICO) meet-point location.

GigE ICO Trunking Arrangement applies an ICO Trunk Connection Charge between the CSME switch location and the ICO meet-point location that is shared with the ILEC (ICO) Ethernet switch. The ICO Trunk Connection Charge is applied to each customer Ethernet Virtual Connection (EVC) that is transported on the GigE trunk backbone to the ICO meet-point. The ICO Trunk Mileage charge is applicable to each customer Ethernet Virtual Connection (EVC) transported across the GigE trunk when mileage exceeds 10 miles. Mileage is calculated from the CSME switch location to the ICO meet-point location.

(N)

(N)

Continued

OTHER SERVICES

(T)

D13. ADVANCED SERVICES

13.2 CUSTOMIZED SWITCHED METRO ETHERNET (CSME) SERVICE (Cont'd)

C. RATE REGULATIONS (Cont'd)

2. Term Pricing Plan (TPP)

a. General

CSME Term Pricing Plan (TPP) provides the customer with rate stabilization and discounted tariff rates. The CSME TPP provides for three (3) and five (5) year terms. Monthly extension will only be offered when a term contract has expired and the customer has not yet signed another term contract.

CSME TPP monthly rates will be exempt from Utility initiated rate increases throughout the selected service period. Should the Utility increase its rates during the CSME TPP service period, the customer would continue to pay the rates in effect at the time the customer elected to establish service under the CSME TPP.

Decreases in CSME TPP monthly recurring tariff rates will be passed on to customers who participate in a CSME TPP.

b. Renewal of Term Pricing Plan

At the end of a Term Pricing Plan, the customer may renew with a written notice of intent to renew no later than 90 days prior to its expiration, for any TPP in effect without incurring new nonrecurring charges.

If the customer elects not to renew the TPP or does not notify the Utility of its intent to renew the TPP, the service will automatically be billed under the Monthly Extension rates in effect at the time the TPP expires until the customer cancels or renews the service with a new TPP term. Subsequently, customers under the Monthly Extension rates may convert their existing service to either a three (3) or five (5) year TPP. The customer will not be assessed any associated non-recurring charges as long as the physical serving arrangement does not change.

Monthly Extensions are not available to new service.

Continued

OTHER SERVICES

(T)

D13. ADVANCED SERVICES

13.2 CUSTOMIZED SWITCHED METRO ETHERNET (CSME) SERVICE (Cont'd)

C. RATE REGULATIONS (Cont'd)

2. Term Pricing Plan (Cont'd)

c. Change of Term Pricing Plan

At any time, a customer may change an existing TPP to a new TPP only when the new TPP payment period is longer than the remaining period currently in effect, without any Termination Liability Charges or nonrecurring charges applying as long as all other aspects of the service and facilities remain unchanged. The new TPP begins on the service order completion date and is treated as a new TPP period.

d. Service Available Under CSME TPP

A customer may elect to participate in the CSME TPP for the CSME Standard Features and Repeater rate elements only.

e. Terms and Conditions

Customers must specify the length of the service period at the time the CSME is established.

Customers may move their existing service to a new location without incurring termination charges provided all of the following conditions are met:

- (1) The customer maintains the existing TPP at the new location or establishes a new TPP equal to or greater than at the old location;
- (2) During the Term Payment Plan, a customer may move CSME location to another premises in the same LATA and keep the Term Plan in force without assessment of Early Termination Liability, provided no lapse in billing occurs;
- (3) The customer's request for disconnect at the existing location and the request for service at the new location are received at the same time;

Continued

OTHER SERVICES

(T)

D13. ADVANCED SERVICES

13.2 CUSTOMIZED SWITCHED METRO ETHERNET (CSME) SERVICE (Cont'd)

C. RATE REGULATIONS (Cont'd)

2. Term Pricing Plan (Cont'd)

e. Terms and Conditions (Cont'd)

Customers may move their existing service to a new location without incurring termination charges provided all of the following conditions are met: (Cont'd)

- (4) The customer's disconnect order for the existing service references the new connect order for the new service;
- (5) Moves of one location to a premise in a different serving office may result in a change in the monthly charges. Nonrecurring charges, as appropriate, are applicable as set forth in Section E. Rates and Charges, following;
- (6) If the customer moves more than one location of the service concurrently the customer will be liable for Termination Liability charges as this is considered a complete disconnect of the service.

(T)

Customers will be allowed to upgrade from CSME to OPT-E-MAN® Service without incurring termination charges provided all of the following conditions are met:

- (1) Customers must request a disconnect order for the existing CSME locations and request a new connect order for OPT-E-MAN® at the same location.
- (2) The term of the new OPT-E-MAN® Service TPP must be equal to or greater than the remaining term on the existing CSME TPP.
- (3) The existing CSME service must be in service for a minimum of fifteen (15) months for a three (3) year TPP or eighteen (18) months for a five (5) year TPP.
- (4) Upgrade to OPT-E-MAN® is subject to the availability of fiber from premise to premise and the availability of OPT-E-MAN® Service. Where facilities and/or operating conditions are not available, Special Construction charges as set forth in Schedule Cal.P.U.C. No. 175-T, Section 15. may apply.
- (5) Customer's network configuration must be remain the same. The number of OPT-E-MAN® locations must be equal to or greater than the current number of CSME locations.
- (6) A minimum of 50% of the bandwidth connection for each individual connection must ordered and maintained for OPT-E-MAN®. Example:

(T)

(T)

Customer has a 1 Gbps CSME bandwidth connection, customer is required to purchase a minimum 500 Mbps OPT-E-MAN® bandwidth connection.

(D)

Continued

OTHER SERVICES

(T)

D13. ADVANCED SERVICES

13.2 CUSTOMIZED SWITCHED METRO ETHERNET (CSME) SERVICE (Cont'd)

C. RATE REGULATIONS (Cont'd)

2. Term Pricing Plan (Cont'd)

f. Termination Charges

In addition to any special construction liabilities, as set forth in Schedule Cal.P.U.C. 175-T, Section 15, customer termination liability for cancellation of CSME TPP shall be equal to: (T)

(1) Any unpaid Special Construction or nonrecurring charges (excluding any waived charges); plus

(2) Fifty percent (50%) of all recurring charges for the remaining months of the customer's term which the customer agrees to pay within 30 days. (T)

(3) The termination charge is calculated as follows:

(Monthly Recurring Rate) x (Months remaining in TPP term) x (Termination Billing Period Percentage) (T)

Example: A customer with a \$1,800.00 monthly rate terminates service with 10 months remaining in a 3 year TPP term. (T)

The termination liability charges would be calculated as follows: (\$1,800.00) x (10) x (.50) = \$9,000.00 (T)

(D)

Continued

OTHER SERVICES

(T)

D13. ADVANCED SERVICES

13.2 CUSTOMIZED SWITCHED METRO ETHERNET (CSME) SERVICE (Cont'd)

D. RESERVED

(T)

(D)

(D)

(D)

(D)

Continued

OTHER SERVICES

(T)

D13. ADVANCED SERVICES

13.2 CUSTOMIZED SWITCHED METRO ETHERNET (CSME) SERVICE (Cont'd)

D. RESERVED (Cont'd)

(T)

(D)

(D)

Continued

OTHER SERVICES

(T)

D13. ADVANCED SERVICES

13.2 CUSTOMIZED SWITCHED METRO ETHERNET (CSME) SERVICE (Cont'd)

E. CURRENT RATES AND CHARGES

| | <u>Non-Recurring Charges</u> | <u>36 Months</u> | <u>60 Months</u> | <u>Monthly Extension</u> | |
|---|----------------------------------|----------------------|----------------------|------------------------------|-----|
| Standard Features - per location | | | | | (T) |
| 10 Mbps Connection | \$1,600.00 | \$1,170.00 | \$1,100.00 | \$1,550.00 | (T) |
| Subsequent 10Mbps Connection ¹ | 1,150.00 | 950.00 | 800.00 | 1,200.00 | (T) |
| 100 Mbps Connection | 1,925.00 | 1,665.00 | 1,600.00 | 2,500.00 | (T) |
| Subsequent 100Mbps Connection ¹ | 1,200.00 | 1,200.00 | 1,025.00 | 1,560.00 | (T) |
| 1 Gbps | 2,500.00 | 3,220.00 | 3,080.00 | 3,900.00 | (T) |

| | <u>Non-Recurring Charges</u> | <u>Monthly Charges</u> |
|--|----------------------------------|----------------------------|
| Ethernet Virtual Connection (EVC) - per connection | \$70.00 | \$25.00 |

NOTE 1: Any subsequent 10 Mbps or 100 Mbps Connections must be terminate at the same locations as the original 10 Mbps or 100 Mbps Connections.

Continued

OTHER SERVICES

(T)

D13. ADVANCED SERVICES

13.2 CUSTOMIZED SWITCHED METRO ETHERNET (CSME) SERVICE (Cont'd)

E. CURRENT RATES AND CHARGES (Cont'd)

| | <u>Non-Recurring Charge</u> | <u>Monthly Charge</u> | | |
|---------------------------------------|----------------------------------|---------------------------|----------------------|------------------------------|
| Additional MAC Addresses - 151-200 | \$70.00 | \$5.00 | (T) | |
| Service Order Change Charge | 75.00 | NA | (D) (T) | |
| Miscellaneous Change Charge | 100.00 | NA | (D) (T) | |
| Service Order Cancellation Charge | 200.00 | NA | | |
| Order Expedite | 300.00 | NA | | |
| | <u>Non-Recurring Charges</u> | <u>36 Months</u> | <u>60 Months</u> | <u>Monthly Extension</u> |
| Repeater | \$250.00 | \$400.00 | \$375.00 | \$475.00 |

Continued

OTHER SERVICES

D13. ADVANCED SERVICES

13.2 CUSTOMIZED SWITCHED METRO ETHERNET (CSME) SERVICE (Cont'd)
 E. CURRENT RATES AND CHARGES (Cont'd)

| | <u>Nonrecurring Charge</u> | <u>Monthly Charge</u> | (N) |
|--------------------------------------|--|------------------------------|----------------------|
| Meet-Point Billing Options | | | |
| - Direct LEC Connection, Mileage | | | |
| Above 0 and inclusive of 10 miles | \$1,200.00 | \$500.00 | |
| Above 10 and inclusive of 25 miles | 1,200.00 | 1,000.00 | |
| Above 25 and inclusive of 35 miles | 1,200.00 | 1,500.00 | |
| Above 35 and inclusive of 50 miles | 1,200.00 | 2,500.00 | |
| | <u>Nonrecurring Charge¹</u> | <u>36 Months</u> | <u>60 Months</u> |
| | | <u>Monthly Extension</u> | |
| - GigE ICO Trunking Arrangement | | | |
| ICO Trunk Connection Charge, per EVC | | | |
| 10 Mbps | \$525.00 | \$420.00 | \$360.00 |
| 100 Mbps | 800.00 | 840.00 | 720.00 |
| 1 Gbps | 1,100.00 | 4,830.00 | 4,100.00 |

NOTE 1: Nonrecurring charges will be waived for those customers selecting the 36 or 36 or 60 month Term Pricing Plan (TPP) period for new service.

(N)

Continued

OTHER SERVICES

D13. ADVANCED SERVICES

13.2 CUSTOMIZED SWITCHED METRO ETHERNET (CSME) SERVICE (Cont'd)
 E. CURRENT RATES AND CHARGES (Cont'd)

| | <u>Monthly Charge</u> | (N) |
|--|---------------------------|-----|
| Meet-Point Billing Options (cont'd) | | |
| - GigE ICO Trunking Arrangement (cont'd) | | |
| ICO Trunk Mileage, per EVC | | |
| Above 0 and inclusive of 10 miles | N/A | |
| Above 10 and inclusive of 25 miles | | |
| 10 Mbps | \$170.00 | |
| 100 Mbps | 375.00 | |
| 1 Gbps | 1,500.00 | |
| Above 25 and inclusive of 35 miles | | |
| 10 Mbps | 270.00 | |
| 100 Mbps | 675.00 | |
| 1 Gbps | 1,750.00 | |
| Above 35 and inclusive of 50 miles | | |
| 10 Mbps | 410.00 | |
| 100 Mbps | 1,100.00 | |
| 1 Gbps | 2,000.00 | (N) |

Continued

OTHER SERVICES

D13. ADVANCED SERVICES

LIST OF EFFECTIVE SHEET

Sheets listed below are effective as of the date shown on each sheet.

| <u>Revision Number</u> | <u>Sheet</u> | <u>Revision Number</u> | <u>Sheet</u> |
|------------------------|--------------|------------------------|--------------|
| 14th | CS A | 5th ² | 10 |
| 15th ¹ | CS A | 4th ² | 11 |
| 5th | ToC A | 5th ² | 12 |
| 6th ¹ | ToC A | 6th ² | 13 |
| 6th ² | 1 | 4th ² | 14 |
| 4th ² | 2 | 6th ² | 15 |
| 7th ² | 2.1 | 9th ² | 16 |
| Original ² | 2.2 | 5th ² | 17 |
| 6th ² | 3 | 1st ² | 18 |
| 3rd ² | 3.1 | 1st ² | 19 |
| Original ² | 3.2 | 2nd ² | 20 |
| 6th ² | 4 | 1st ² | 21 |
| 7th ² | 5 | 1st ² | 22 |
| 6th ² | 5.1 | 2nd ² | 23 |
| 5th ² | 5.2 | 1st ² | 24 |
| 5th ² | 5.3 | 1st ² | 25 |
| 5th ² | 5.4 | 1st ² | 26 |
| 3rd ² | 5.5 | 2nd ² | 27 |
| 3rd ² | 5.6 | 2nd ² | 28 |
| 4th ² | 5.7 | 2nd ² | 29 |
| 2nd ² | 5.8 | 1st ² | 29.1 |
| 6th ² | 6 | 2nd ² | 30 |
| 6th ² | 7 | 2nd ² | 31 |
| 5th ² | 8 | 2nd ² | 32 |
| 5th ² | 9 | 2nd ² | 33 |

NOTE 1: Issued

NOTE 2: Advice Letter No. 33423 (effective November 1, 2008) cancels Table (N)
 of Contents Sheet A through Sheet 33. (N)

CC: 5170