

**ACCESS SERVICE**

**17. Network Management Services**

The following list matches the Telephone Company's Basic Service Element (BSE) names to the industry standard names for each BSE.

<u>Telephone Company Names</u>	<u>Generic Name of ONA Service</u>	
Network Reconfiguration <sup>/1/</sup>	Network Reconfiguration	(C)

/1/ Effective December 5, 2018, Network Reconfiguration Service (NRS) will no longer be available for purchase by new or existing customers, and NRS service agreements may no longer be renewed. Effective July 31, 2022, the Telephone Company will no longer accept new requests for physical changes to existing service arrangements including the upgrade or downgrade of access/port speed, installation of new service, or moves to different service addresses.

(N)  
|  
(N)

**ACCESS SERVICE****17. Network Management Services (Cont'd)****17.1 Network Reconfiguration Service<sup>/1/</sup>**

(C)

**17.1.1 General**

Network Reconfiguration Service is a BSE that permits customers to access a database maintained by the Telephone Company to reconfigure their dedicated network. Customers gain database access through the use of a terminal on their premises without going through normal service order procedures.

Network Reconfiguration Service allows customers direct access to, and control of, their 45 Mbps services, their 1.544 Mbps services, subtending channels, and Internodal Facilities (the facilities that connect a Digital Cross-Connect system in one central office with a Digital Cross-Connect System in another central office), without going through normal service order procedures. Network Reconfiguration Service utilizes a central office cross-connect system for the remote reconfiguration of these channels. Customers can reconfigure their dedicated service network from their premises, or they can have the Telephone Company perform the reconfigurations.

Customers will access Network Reconfiguration Service by using a terminal on their premises in conjunction with dedicated lines provided for in Sections 7 and 16, or in conjunction with a local telephone line with a seven digit telephone number.

Network Reconfiguration Service is available at those Hubs where Telephone Company cross-connect systems are located. Network Reconfiguration Hub designations are found in the NECA Tariff FCC No. 4.

**17.1.2 Network Reconfiguration Options**

Two network reconfiguration options are available to Network Reconfiguration customers:

- On-demand
- Reservation

<sup>/1/</sup> Effective December 5, 2018, Network Reconfiguration Service (NRS) will no longer be available for purchase by new or existing customers, and NRS service agreements may no longer be renewed. Effective July 31, 2022, the Telephone Company will no longer accept new requests for physical changes to existing service arrangements including the upgrade or downgrade of access/port speed, installation of new service, or moves to different service addresses.

(N)

(N)

**ACCESS SERVICE****17. Network Management Services (Cont'd)****17.1 Network Reconfiguration Service (Cont'd)<sup>1/</sup>**

(C)

**17.1.2 Network Reconfiguration Options (Cont'd)**

The on-demand option will make immediate changes to the network, while the reservation option will be executed at a specified time designated by the customer. Both types of reconfigurations are available whether the customer performs the reconfigurations or requests the Telephone Company to perform them.

**17.1.3 Network Reconfiguration Functions**

Network Reconfiguration Service provides the following options:

**(A) Routing/Rerouting**

The routing feature allows customers to select the routes that will be used to connect their circuits between DCSs. The route selection process can be controlled by various parameters according to the customer's needs. Rerouting of circuits off of a failed internodal facility to a working one is also available.

**(B) Renaming**

Renaming permits customers to rename their network locations, circuits, and facilities.

**(C) Special Day Definition**

Special day definition gives customers the capability to specify circuit reconfiguration on special dates, e.g., payday, holidays.

**(D) Resource Verification**

Resource verification allows customers to verify the resource availability for the reservation period in their reconfiguration request prior to the system's confirmation or denial of the request.

**(E) Transaction Log**

Transaction log provides customers a database log that contains every transaction involving reconfigurations.

<sup>1/</sup> Effective December 5, 2018, Network Reconfiguration Service (NRS) will no longer be available for purchase by new or existing customers, and NRS service agreements may no longer be renewed. Effective July 31, 2022, the Telephone Company will no longer accept new requests for physical changes to existing service arrangements including the upgrade or downgrade of access/port speed, installation of new service, or moves to different service addresses.

(N)

(N)

**ACCESS SERVICE**

**17. Network Management Services (Cont'd)**

**17.1 Network Reconfiguration Service (Cont'd)<sup>1/</sup>**

(C)

**17.1.3 Network Reconfiguration Functions (Cont'd)**

**(F) Multi-Level Security**

Multi-level security eliminates the unauthorized entry into a customer's circuit network arrangement inventory.

**(G) Compatibility Table**

Compatibility table permits customers to view the allowable access line combinations that can be used with Network Reconfiguration Service.

**(H) Path Priority**

Path priority gives customers the ability to arrange their circuit paths in order of priority when multiple routes exist.

**(I) Reservation Summary Screen**

Reservation summary screen allows customers to view the status of their reconfiguration reservations.

**(J) Simple Commands and Screens**

Simple commands and screens permit customers to use simple commands on screens with easy to use menus.

**(K) MACRO Command/Network Modeling**

MACRO command/network modeling (i.e., model request) gives customers the ability to initiate with one command, multiple two-point cross-connections. Customers can build separate network models, such as day-time models, night-time models, and disaster recovery models and invoke their activation or switch from one to the other.

<sup>1/</sup> Effective December 5, 2018, Network Reconfiguration Service (NRS) will no longer be available for purchase by new or existing customers, and NRS service agreements may no longer be renewed. Effective July 31, 2022, the Telephone Company will no longer accept new requests for physical changes to existing service arrangements including the upgrade or downgrade of access/port speed, installation of new service, or moves to different service addresses.

(N)  
|  
(N)

---

**ACCESS SERVICE**

**17. Network Management Services (Cont'd)**

**17.1 Network Reconfiguration Service (Cont'd)<sup>/1/</sup>**

(C)

**17.1.3 Network Reconfiguration Functions (Cont'd)**

**(L) Variable Bandwidth**

Variable bandwidth applies to an Internodal Facility and permits it to be used interchangeably to connect full 45 Mbps or 1.544 Mbps services, or to connect one or more individual subtending channels.

**17.1.4 Technical Specifications**

Services that are cross-connected by Network Reconfiguration Service must have identical technical characteristics to ensure compatibility and proper operation, e.g., Data to Data, Voice to Voice.

Network Reconfiguration Service specifications are delineated in Technical Reference TR-TSY-000366.

**17.1.5 Rate Regulations**

This section contains a description of the rate elements applicable to Network Reconfiguration Service. Rates and charges associated with the rate elements are listed in 17.1.6.

**(A) Rate Element Descriptions**

**(1) Service Establishment**

The Service Establishment charge applies per customer database setup. The customer database setup is a grid, built by the Telephone Company, that contains all the circuits the customer will be able to control and reconfigure. Security, as well as circuit inventory, is built into the grid, permitting the customer control of its own circuits. Also included is the provisioning of customer training. This charge includes the connection of the initial circuits.

<sup>/1/</sup> Effective December 5, 2018, Network Reconfiguration Service (NRS) will no longer be available for purchase by new or existing customers, and NRS service agreements may no longer be renewed. Effective July 31, 2022, the Telephone Company will no longer accept new requests for physical changes to existing service arrangements including the upgrade or downgrade of access/port speed, installation of new service, or moves to different service addresses.

(N)  
|  
(N)

**ACCESS SERVICE**

**17. Network Management Services (Cont'd)**

**17.1 Network Reconfiguration Service (Cont'd)<sup>1/</sup>**

(C)

**17.1.5 Rate Regulations (Cont'd)**

**(A) Rate Element Descriptions (Cont'd)**

**(2) Database Modification**

This charge applies (per customer contact, or request) each time the customer requests a subsequent modification of its database. A modification can be an addition or deletion of circuits terminating on the cross-connect system, or a rearrangement of the database, e.g., an outside move, a change in the signaling characteristics of a circuit (e.g., from data to voice), a rearrangement of the customer's routing priority between nodes, virtual port establishment, etc.

**(3) Port Charges**

Port Charges apply per port termination on the cross-connect system. There are three types of charges:

- Subtending Port Charge - applies per subtending channel port termination for all Special Access services (64 kbps and below or 45 Mbps service) per circuit on the cross-connect system.
- 1.544 Mbps Port Charge - applies for 128 kbps - 1.544 Mbps channel port termination per circuit on the cross-connect system.
- 45 Mbps Port Charge - applies for 45 Mbps channel port termination per circuit on the cross-connect system.

Two Port Charges apply per circuit connecting 2 Network Reconfiguration Hubs or 2 cross-connect systems within the same Network Reconfiguration Hub (with one Port Charge applying at each termination of the circuit).

<sup>1/</sup> Effective December 5, 2018, Network Reconfiguration Service (NRS) will no longer be available for purchase by new or existing customers, and NRS service agreements may no longer be renewed. Effective July 31, 2022, the Telephone Company will no longer accept new requests for physical changes to existing service arrangements including the upgrade or downgrade of access/port speed, installation of new service, or moves to different service addresses.

(N)  
|  
(N)

**ACCESS SERVICE**

**17. Network Management Services (Cont'd)**

**17.1 Network Reconfiguration Service (Cont'd)<sup>1/</sup>**

(C)

**17.1.5 Rate Regulations (Cont'd)**

**(A) Rate Element Descriptions (Cont'd)**

**(4) Reconfiguration Charges**

Full 45 Mbps or 1.544 Mbps service bandwidth, sub 45 Mbps or 1.544 Mbps bandwidth, contiguous subtending channel groupings (up to and including all 24 subtending channels within a 1.544 Mbps service), contiguous 1.544 Mbps service groupings (up to and including all 28 1.544 Mbps services within a 45 Mbps service), or individual subtending channel or 1.544 Mbps service arrangements are as specified by the customer at the time NRS service is established. This specification limits the parameters within which the service can be reconfigured and defines how reconfiguration charges will apply. If reconfiguration is at the subtending channel, 1.544 Mbps or 45 Mbps level, one reconfiguration charge applies per subtending channel, 1.544 Mbps service or 45 Mbps circuit reconfigured; if reconfiguration is for a previously defined contiguous group of subtending channels, one reconfiguration charge applies per group of subtending channels reconfigured; etc. One reconfiguration charge applies per cross-connect and/or disconnect successfully completed in a DCS per request.

There are two types of reconfiguration charges:

- For individual reservation or demand requests performed by the customer, or for each segment of a model request performed by the customer or Telephone Company.
- For individual reservation or demand requests performed by the Telephone Company at the customer's request.

For example, if a customer wishes to reconfigure a circuit that is routed through two NRS Hub offices (the existing circuit being routed between customer premises A through the two NRS Hub offices to customer premises B, and the customer wishes to reconfigure the circuit to be rerouted between customer premises A through the two NRS Hub offices to customer premises C), two transactions would occur: one transaction to disconnect the circuit between premises A and B, and one transaction to reconnect the circuit between premises A and C. The customer would be billed four NRS charges: two for disconnecting the circuit (one for each disconnect at each NRS Hub), and two for reconnecting the circuit (one for each reconnect at each NRS Hub).

<sup>1/</sup> Effective December 5, 2018, Network Reconfiguration Service (NRS) will no longer be available for purchase by new or existing customers, and NRS service agreements may no longer be renewed. Effective July 31, 2022, the Telephone Company will no longer accept new requests for physical changes to existing service arrangements including the upgrade or downgrade of access/port speed, installation of new service, or moves to different service addresses.

(N)  
|  
(N)

**ACCESS SERVICE**

**17. Network Management Services (Cont'd)**

**17.1 Network Reconfiguration Service (Cont'd)<sup>1/</sup>**

(C)

**17.1.5 Rate Regulations (Cont'd)**

**(B) Application of Rates**

When Network Reconfiguration Service is used in conjunction with Special Access or MegaLink Custom services, the appropriate regulations, rates and charges as set forth in Sections 7 and 16 will apply in addition to charges as set forth in 17.1.6:

- One Channel Termination (CT) applies between the customer premises and serving wire center
- Channel Mileage or Interoffice Mileage, if applicable, applies between the serving wire center and the Telephone Company Network Reconfiguration Hub, or between two Network Reconfiguration Hubs.

Nonrecurring charges, as set forth in Sections 7 and 16, are also applicable when existing channels must be reterminated in a Network Reconfiguration Port to provide Network Reconfiguration Service. When an existing DS3 circuit is reterminated in a Network Reconfiguration Port, termination charges as set forth in 16.4.5 (Minimum Service Periods), 16.4.6 (Termination Charges) and 16.4.12(C) (Moving Customer Premises), will only apply to the Optional Features, BSEs and Functions associated with the reterminated DS3 circuit. Termination charges will not apply to Channel Terminations and Interoffice Mileage associated with the reterminated DS3 circuit when the DS3 end points involved do not change.

When a new or existing High Capacity Term Pricing Plan (HC-TPP) customer subscribes to or has a 3 or 5 year HC-TPP, as described in Section 7.2.20 (High Capacity Term Pricing Plan (HC-TPP)) and requests an associated NRS with that HC-TPP DS1 circuit terminating on the NRS, NRS recurring rates and nonrecurring charges associated with the Service Establishment Charge, 1.544 Mbps Port Charge and the Database modification Charge, as it applies to the addition of a DS1 circuit, rate elements will be waived as long as the NRS is associated with a DS1 circuit under the HC-TPP. The existing HC-TPP customer must renew the HC-TPP to receive the waiver of applicable NRS charges.

<sup>1/</sup> Effective December 5, 2018, Network Reconfiguration Service (NRS) will no longer be available for purchase by new or existing customers, and NRS service agreements may no longer be renewed. Effective July 31, 2022, the Telephone Company will no longer accept new requests for physical changes to existing service arrangements including the upgrade or downgrade of access/port speed, installation of new service, or moves to different service addresses.

(N)  
|  
(N)



ACCESS SERVICE

17. Network Management Services (Cont'd)

17.1 Network Reconfiguration Service (Cont'd)<sup>/1/</sup>

(C)

17.1.5 Rate Regulations (Cont'd)

(C) Service Configurations

The following diagram depicts a typical Network Reconfiguration Network with its applicable rate elements:

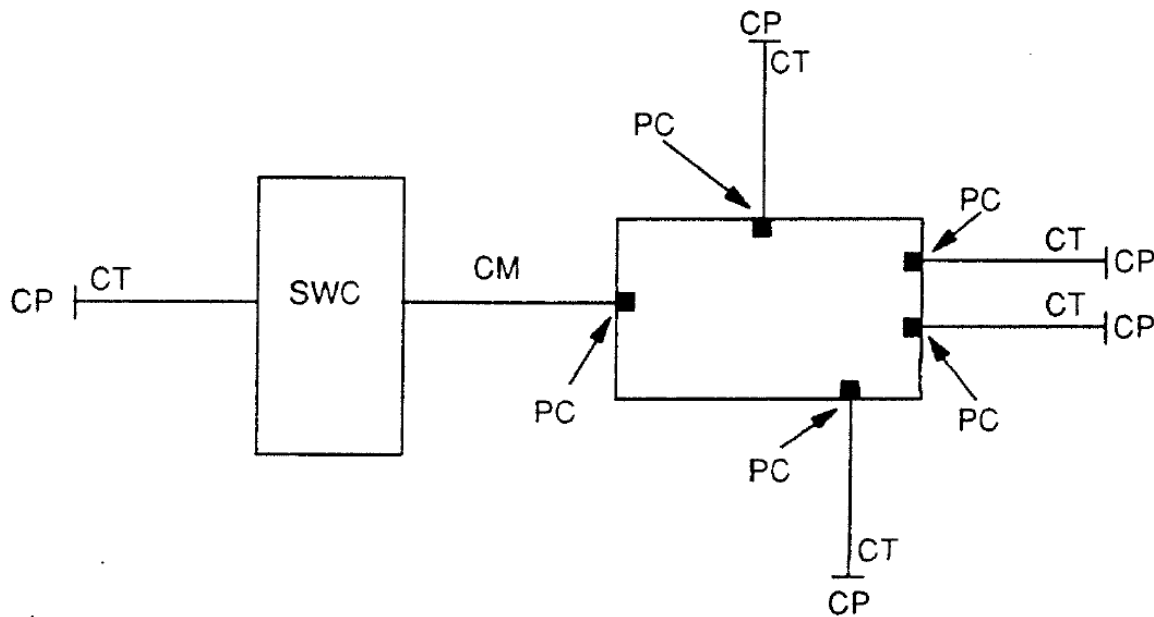

- CM = Channel Mileage
- CP = Customer Premises
- CT = Channel Termination
- NRH = Network Reconfiguration Hub
- PC = Port Charge
- SWC = Serving Wire Center

<sup>/1/</sup> Effective December 5, 2018, Network Reconfiguration Service (NRS) will no longer be available for purchase by new or existing customers, and NRS service agreements may no longer be renewed. Effective July 31, 2022, the Telephone Company will no longer accept new requests for physical changes to existing service arrangements including the upgrade or downgrade of access/port speed, installation of new service, or moves to different service addresses.

(N)  
|  
(N)

ACCESS SERVICE

17. Network Management Services (Cont'd)

17.1 Network Reconfiguration Service (Cont'd)<sup>/1/</sup>

(C)

17.1.5 Rate Regulations (Cont'd)

(C) Service Configurations (Cont'd)

The following diagram depicts a Network Reconfiguration Network utilizing two Network Reconfiguration Hubs:

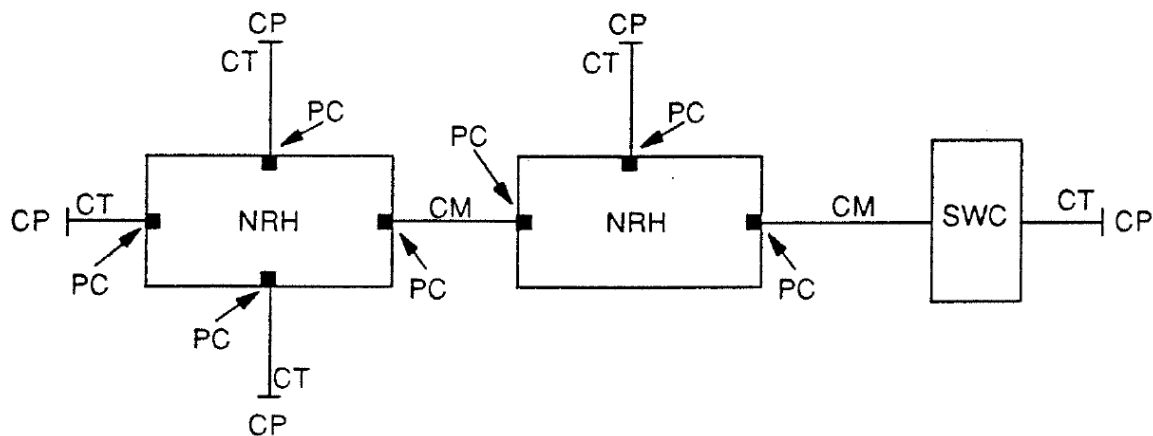

- CM = Channel Mileage
- CP = Customer Premises
- CT = Channel Termination
- NRH = Network Reconfiguration Hub
- PC = Port Charge
- SWC = Serving Wire Center

/1/ Effective December 5, 2018, Network Reconfiguration Service (NRS) will no longer be available for purchase by new or existing customers, and NRS service agreements may no longer be renewed. Effective July 31, 2022, the Telephone Company will no longer accept new requests for physical changes to existing service arrangements including the upgrade or downgrade of access/port speed, installation of new service, or moves to different service addresses.

(N)  
|  
(N)

**ACCESS SERVICE**

**17. Network Management Services (Cont'd)**

**17.1 Network Reconfiguration Service (Cont'd)<sup>/1/</sup>**

(C)

**17.1.6 Rates and Charges**

	<u>Monthly Rates</u>	<u>Nonrecurring Charges</u>
<b>(A) Service Establishment Charge (FN6DD)</b>		
Per Database Setup	\$ 0.00	\$ 1,722.00
<b>(B) Database Modification Charge (FN6DC)</b>		
Per request	0.00	80.00
<b>(C) Port Charges</b>		
<b>(1)</b> Subtending Channel Port (PT5)	12.00	20.00
<b>(2)</b> 1.544 Mbps Port (PT6)	45.14	43.00
<b>(3)</b> 45 Mbps Port (D3D)	490.05	32.00
<b>(D) Reconfiguration Charges</b>		
Per Cross Connect and/or Disconnect Successfully Completed		
<b>(1)</b> Individual Reservation or Demand Request performed by the Customer; or Each Segment of a Model Request Performed by customer or Telephone Company	0.00	1.25
<b>(2)</b> Individual Reservation or Demand Request Performed by the Telephone Company at the customer's Request	0.00	8.00

/1/ Effective December 5, 2018, Network Reconfiguration Service (NRS) will no longer be available for purchase by new or existing customers, and NRS service agreements may no longer be renewed. Effective July 31, 2022, the Telephone Company will no longer accept new requests for physical changes to existing service arrangements including the upgrade or downgrade of access/port speed, installation of new service, or moves to different service addresses.

(N)  
|  
(N)