

TARIFF DISTRIBUTION

FILE PACKAGE NO.: AL-21-0030

DATE: August 4, 2021

STATE: ALABAMA

EFFECTIVE DATE: 06/30/2021

TYPE OF DISTRIBUTION: Approved

PURPOSE: Grandfather Metallic, Telegraph, Voice Grade,
WATS, Digital Link, and Derived Data Services
effective 6/30/21 with targeted sunset
6/30/24.

<u>TARIFF SECTION</u>	<u>PAGE NUMBER</u>	<u>PAGE REVISION</u>
E007	1	0014
E007	2	0010
E007	4	0004
E007	5	0004
E007	6	0005
E007	7	0013
E007	8	0011
E007	9.1	0005
E007	10	0005
E007	11	0008
E007	12	0007
E007	12.1	0006
E007	13	0007
E007	13.1	0006
E007	14	0010
E007	15	0008
E007	16	0007
E007	16.1	0007
E007	20	0005
E007	21	0010
E007	21.1	0005
E007	22	0008
E007	23.1	0008
E007	24	0016
E007	24.3	0003
E007	25	0007
E007	26	0008
E007	27	0004
E007	49.1	0016

E007	50.1	0010
E007	51	0012
E007	51.1	0002
E007	55	0011
E007	56	0012
E007	57.1	0008
E007	58	0008
E007	59	0006
E007	59.1	0005
E007	60	0008
E007	60.1	0008
E007	60.2	0005
E007	65.1	0010
E007	66	0006
E007	67	0009
E007	67.1	0008
E007	67.2	0007
E007	70	0009
E007	70.1	0009

BELLSOUTH
TELECOMMUNICATIONS
ALABAMA
ISSUED: May 28, 2021
BY: President - Alabama
Birmingham, Alabama

ACCESS SERVICES TARIFF

Fourteenth Revised Page 1
Cancels Thirteenth Revised Page 1

EFFECTIVE: June 30, 2021

E7. SPECIAL ACCESS (A.K.A. BELLSOUTH SPA) SERVICE**E7.1 General**

Special Access (a.k.a. BellSouth SPA) service provides a transmission path to connect customer designated premises¹, either directly or through a Company Hub where bridging or channelization functions are performed. Special Access (a.k.a. BellSouth SPA) service² includes all exchange access not utilizing Company end office switches.

The connections provided by Special Access (a.k.a. BellSouth SPA) service can be either analog or digital. Analog connections are differentiated by spectrum and bandwidth. Digital connections are differentiated by bit rate.

E7.1.1 Channel Types

There are different types of channels used to provide Special Access (a.k.a. BellSouth SPA) services. Each type has its own characteristics. All are subdivided by one or more of the following:

- Transmission specifications
- Bandwidth
- Speed (i.e., bit rate)
- Spectrum

Customers can order a basic channel and select from a list of available transmission parameters and channel interfaces, those that they desire to meet specific communications requirements.

For purposes of ordering channels, each has been identified as a type of Special Access (a.k.a. BellSouth SPA) service. However, such identification is not intended to limit a customer's use of the channel not to imply that the channel is limited to a particular use. For example, if a customer's equipment is capable of transmitting voice over a channel that is identified as Metallic (a.k.a. BellSouth SPA Metallic)³ service in this Tariff, there is no restriction against doing so. (C)

Following is a brief description of each type of channel:

Voice Grade (a.k.a. BellSouth SPA DS0 VG)³ - a channel for the transmission of analog signals within an approximate bandwidth of 300-3000 Hz. (C)

Digital Data Access (a.k.a. BellSouth SPA DS0 Digital Data)³ - a channel for the digital transmission of synchronous serial data at rates of 2.4, 4.8, 9.6, 19.2, 56.0 or 64 Kbps. (C)

High Capacity (a.k.a. BellSouth SPA High Capacity) - a channel for the transmission of isochronous serial digital data at rates of 1.544, 3.152, 6.312, or 44.736 Mbps.

(DELETED)

Note 1: Company Centrex Type Services switches and Company Answering Service Concentrators are considered to be customer premises for purposes of administering regulations and rates contained in this Tariff.

Note 2: For purposes of administering the surcharge regulations, WATS (a.k.a. BellSouth SPA WATS Line) access lines are considered to be Special Access (a.k.a. BellSouth SPA) service.

Note 3: Effective June 30, 2021, this Service will no longer be available for purchase by new or existing customers. In addition, requests to move, add, change, or renew existing service arrangements will not be accepted. Following the expiration of a customer's existing term agreement, service will be provided on a month-to-month basis at the applicable Monthly rates until the service is discontinued. The Company currently plans to discontinue this service on or after June 30, 2024. (N)

(N)
|
(N)

BELLSOUTH
TELECOMMUNICATIONS
ALABAMA
ISSUED: May 28, 2021
BY: President - Alabama
Birmingham, Alabama

ACCESS SERVICES TARIFF

Tenth Revised Page 2
Cancels Ninth Revised Page 2

EFFECTIVE: June 30, 2021

E7. SPECIAL ACCESS (A.K.A. BELLSOUTH SPA) SERVICE**E7.1 General (Cont'd)****E7.1.1 Channel Types (Cont'd)**

Detailed descriptions of each of the channel types are provided in E7.2 following.

The customer also has the option of ordering high capacity service (i.e., 1.544 Mbps, 3.152 Mbps, 6.312 Mbps, and 44.736 Mbps) to a Company Hub for channelization to individual channels of a lower capacity or bandwidth. Descriptions of the types of channelization available at the hubs, as well as the number of individual channels which may be derived from each type of facility are set forth in E7.2 following. Additionally, the customer may specify optional features for the individual channels derived from the facility to further tailor the channel to meet specific communications requirements. Descriptions of the optional features and functions available are also set forth in E7.2 following.

For example, a customer may order a 44.736 Mbps facility from a customer designated premises to a Company Hub for channelization to twenty-eight 1.544 Mbps channels. The 1.544 Mbps channels may be further channelized at the same or a different Hub to Voice Grade (a.k.a. BellSouth SPA DS0 VG)¹ channels or may be extended to other customer designated premises. (C)

E7.1.2 Rate Categories

There are *four* basic rate categories which apply to Special Access (a.k.a. BellSouth SPA) service:

- Local Channels (described in A. following)
- Interoffice Channel (described in B. following)
- Optional Features and Functions (described in C. following)
- SMARTRing[®] service (a.k.a. BellSouth Dedicated Ring)

A. Local Channel

The Local Channel rate category provides for the communications path between the demarcation point at a customer premises and the serving wire center of that premises. Included as part of the Local Channel is a standard channel interface arrangement which defines the technical characteristics associated with the type of facilities to which the access service is to be connected at the Point of Termination (POT) and the type of signaling capability, if any. The signaling capability itself is provided as an optional feature as set forth in E7.1.1.C. One Local Channel charge applies per customer designated premises at which the channel is terminated. This charge will apply even if the customer premises and the serving wire center are co-located in a Company building. A Hub Termination charge applies in addition to each Digital Data Access (a.k.a. BellSouth SPA DS0 Digital Data)¹ service Local Channel. (C)

B. Interoffice Channel

The Interoffice Channel rate category provides for the transmission facilities between the serving wire centers associated with two customer designated premises, between a serving wire center associated with a customer designated premises and a Company Hub or between two Company Hubs. Interoffice Channel is portrayed in mileage bands. There are two rates that apply for each band, i.e., a flat rate per band and a rate per mile.

C. Optional Features and Functions

The Optional Features and Functions rate category provides for optional features and functions which may be added to a Special Access (a.k.a. BellSouth SPA) service to improve its quality or utility to meet specific communications requirements. These are not necessarily identifiable with specific equipment, but rather represent the end result in terms of performance characteristics which may be obtained. These characteristics may be obtained by using various combinations of equipment. Although the equipment necessary to perform a specified function may be installed at various locations along the path of the service, they will be charged for as a single rate element.

Note 1: Effective June 30, 2021, this Service will no longer be available for purchase by new or existing customers. In addition, requests to move, add, change, or renew existing service arrangements will not be accepted. Following the expiration of a customer's existing term agreement, service will be provided on a month-to-month basis at the applicable Monthly rates until the service is discontinued. The Company currently plans to discontinue this service on or after June 30, 2024. (N)

E7. SPECIAL ACCESS (A.K.A. BELLSOUTH SPA) SERVICE

E7.1 General (Cont'd)

E7.1.3 Service Configurations (Cont'd)

A. Two-Point Service (Cont'd)

The following diagram depicts a two-point Voice Grade (*a.k.a. BellSouth SPA DS0 VG*)³ service connecting two customer designated premises located 15 miles apart. The service is provided with C-Type Conditioning. (C)

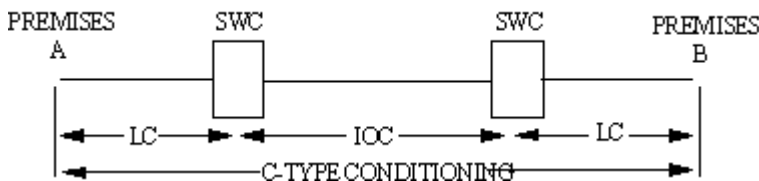

LC – Local Channel
 IOC – Interoffice Channel**
 SWC – Serving Wire Center

Applicable rate elements are:

- Local Channels¹ (2 applicable)
- Interoffice Channels² (mileage band Over 9 thru 25 miles)
- C-Type conditioning Optional Feature

B. Multipoint Service

Multipoint service connects three or more customer designated premises through a Company Hub. There is no limitation on the number of mid-links available with multipoint service. However, when more than three mid-links are provided in tandem, the quality of the service may be degraded. A mid-link is a channel between hubs (i.e., bridging locations). Only certain types of Special Access (*a.k.a. BellSouth SPA*) service are provided as multipoint service. These are so designated in the Service Descriptions set forth in E7.2. following.

When ordering, the customer will specify the desired bridging Hub(s) selected from the Exchange Carrier Association Tariff F.C.C. No. 4. This tariff identifies the type(s) of bridging functions which are available and the serving wire centers at which they are available.

- Note 1: Two Local Channels are applicable except with WATS Access Line (*a.k.a. BellSouth SPA WATS Line*) service. WAL service requires only one Local Channel for the (end users) customer designated premises and none for the WATS serving office.
- Note 2: Interoffice Mileage is applicable to a WATS Access Line (*a.k.a. BellSouth SPA WATS Line*) Extension (WALE) when the WATS serving office and the customer's Serving Wire Center (SWC) are not collocated.
- Note 3: Effective June 30, 2021, this Service will no longer be available for purchase by new or existing customers. In addition, requests to move, add, change, or renew existing service arrangements will not be accepted. Following the expiration of a customer's existing term agreement, service will be provided on a month-to-month basis at the applicable Monthly rates until the service is discontinued. The Company currently plans to discontinue this service on or after June 30, 2024.

(N)
 |
 (N)

E7. SPECIAL ACCESS (A.K.A. BELLSOUTH SPA) SERVICE

E7.1 General (Cont'd)

E7.1.3 Service Configurations (Cont'd)

B. Multipoint Service (Cont'd)

Applicable Rate Elements are:

- Local Channels (one per customer designated premises)
- Interoffice Channels (as applicable between each designated customer premises and the Hub and between Hubs)
- Bridging
- Additional Optional Features (when applicable)

In addition, a Special Access (*a.k.a. BellSouth SPA*) Surcharge as set forth in E7.4.2. following and a Message Station Equipment Recovery Charge as set forth in E7.4.3. following may be applicable.

Example: Voice Grade (*a.k.a. BellSouth SPA DS0 VG*)¹ multipoint connecting four customer premises via two customer specified bridging hubs.

(C)

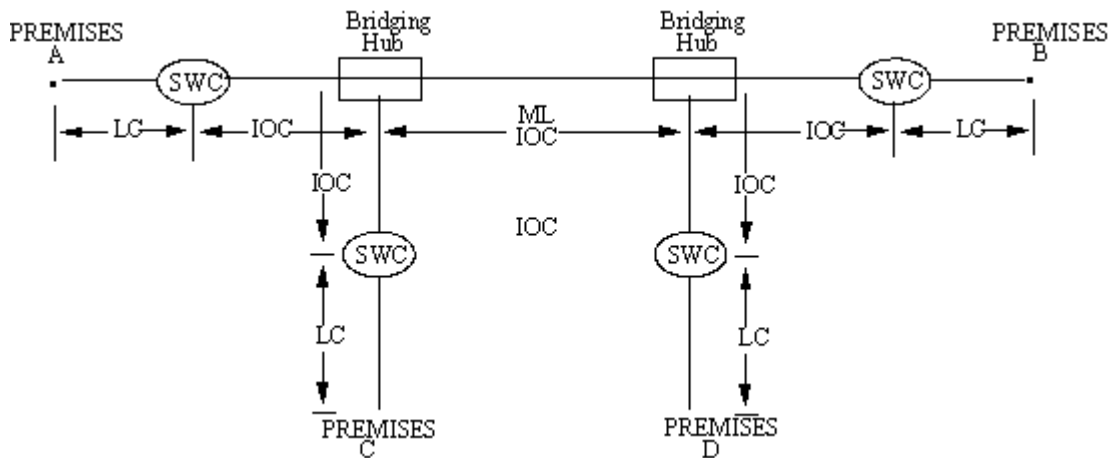

- LC = Local Channel
- IC = Interoffice Channel
- B = Bridging
- SWC = Serving Wire Center

Applicable rate elements are:

- Local Channels (4 applicable)
- Interoffice Channels (5 sections, each from appropriate mileage band)
- Bridging Optional Feature (6 applicable, i.e., each bridge port)

Note 1: Effective June 30, 2021, this Service will no longer be available for purchase by new or existing customers. In addition, requests to move, add, change, or renew existing service arrangements will not be accepted. Following the expiration of a customer's existing term agreement, service will be provided on a month-to-month basis at the applicable Monthly rates until the service is discontinued. The Company currently plans to discontinue this service on or after June 30, 2024.

(N)
|
(N)

BELLSOUTH
TELECOMMUNICATIONS
ALABAMA
ISSUED: May 28, 2021
BY: President - Alabama
Birmingham, Alabama

ACCESS SERVICES TARIFF

Fifth Revised Page 6
Cancels Fourth Revised Page 6

EFFECTIVE: June 30, 2021

E7. SPECIAL ACCESS (A.K.A. BELLSOUTH SPA) SERVICE**E7.1 General (Cont'd)****E7.1.4 Alternate Use**

Alternate Use occurs when a service is arranged by the Company so that the customer can select different types of transmission at different times. A customer may use a service in any privately beneficial manner. However, where technical or engineering changes are required to effectuate an alternate use, the Company will make such special arrangements available on an individual case basis.

The arrangement required to transfer the service from one operation to the other (i.e., the transfer relay and control leads) will be rated and provided on an individual case basis and filed in Section E12., Specialized Service or Arrangements. The customer will pay the stated tariff rates for the Access Service rate elements for the service ordered (i.e., Local Channels, Interoffice Channels, as applicable and Optional Features and Functions, if any).

E7.1.5 Special Facilities Routing

A customer may request that the facilities used to provide Special Access (*a.k.a. BellSouth SPA*) service be specially routed. The regulations, rates and charges for Special Facilities Routing (i.e., Avoidance, Diversity and Cable Only) are set forth in Section E11. following.

E7.1.6 Design Layout Report

At the request of the customer, the Company will provide to the customer the make-up of the facilities and services provided under this Tariff as Special Access (*a.k.a. BellSouth SPA*) service to aid the customer in designing its overall service. This information will be provided in the form of a Design Layout Report.

The Design Layout Report will be provided to the customer at no charge, and will be reissued or updated whenever these facilities are materially changed.

E7.1.7 Acceptance Testing

At no additional charge, the Company will, at the customer's request, cooperatively test, at the time of installation, the following parameters:

- A. For Voice Grade analog (*a.k.a. BellSouth SPA DS0 VG*)¹ services, acceptance tests will include tests for loss, 3-tone slope, DC continuity, operational signaling, C-notched noise and C-message noise when these parameters are applicable and specified in the order for service. Additionally, for Voice Grade (*a.k.a. BellSouth SPA DS0 VG*)¹ services, a balance (improved loss) test will be made if the customer has ordered the improved loss optional feature. (C)
- B. For digital services (i.e., Digital Data Access (*a.k.a. BellSouth SPA DS0 Digital Data*)¹ and High Capacity (*a.k.a. BellSouth SPA High Capacity*)), acceptance tests will include tests for the parameters applicable to the service as specified in the order for service. (C)

In addition to the preceding tests, Additional Cooperative Acceptance Testing for Voice Grade (*a.k.a. BellSouth SPA DS0 VG*)¹ service to test other parameters, as described in E13.3.5.B. following, is available at the customer's request. All test results will be made available to the customer upon request. (C)

E7.1.8 Ordering Options And Conditions

- A. The ordering option available to the customer in the provision of Special Access (*a.k.a. BellSouth SPA*) service is:
 1. Access Order
- B. This option is set forth in detail in Section E5. preceding. Also included in that section are other charges which may be associated with ordering Special Access (*a.k.a. BellSouth SPA*) service (e.g., Service Date Change Charges, Cancellation Charges, etc.).

Note 1: Effective June 30, 2021, this Service will no longer be available for purchase by new or existing customers. In addition, requests to move, add, change, or renew existing service arrangements will not be accepted. Following the expiration of a customer's existing term agreement, service will be provided on a month-to-month basis at the applicable Monthly rates until the service is discontinued. The Company currently plans to discontinue this service on or after June 30, 2024.

(N)
|
(N)

BELLSOUTH
TELECOMMUNICATIONS
ALABAMA
ISSUED: May 28, 2021
BY: President - Alabama
Birmingham, Alabama

ACCESS SERVICES TARIFF

Thirteenth Revised Page 7
Cancels Twelfth Revised Page 7

EFFECTIVE: June 30, 2021

E7. SPECIAL ACCESS (A.K.A. BELLSOUTH SPA) SERVICE**E7.2 Service Description**

For the purpose of ordering, there are different categories of Special Access (a.k.a. BellSouth SPA) service. These are:

- Voice Grade (a.k.a. BellSouth SPA DS0 VG) (VG) ¹ (C)

- Digital Data Access (a.k.a. BellSouth SPA DS0 Digital Data) service (DA) ¹ (C)

- High Capacity (a.k.a. BellSouth SPA High Capacity) (HC)

- Self-Healing Rings (SMARTRing service [a.k.a. BellSouth Dedicated Ring])

Each service consists of a basic channel to which a predefined technical specifications package, channel interface(s) and, when desired, optional features and functions are added to construct the service desired by the customer. Each of the components of the service are described in this section. Terms, conditions, and rates for Physical Access Collocation Cross-Connects and Virtual Access Collocation Cross-Connects are set forth in Section E13. of this Tariff for those services that are permitted to connect directly to a carrier's collocation space.

The channel description specifies the characteristics of the basic channel and indicates whether the channel is provided between customer designated premises or between a customer designated premises and a Company hub where bridging and/or channelization functions are performed.

Information pertaining to the technical specifications packages indicates the transmission parameters that are available with each package. This information is displayed in a matrix with the transmission parameters listed down the left side and the packages listed across the top. Each package is identified by a code, e.g., VG1. The first two letters of the code indicate the category of Special Access (a.k.a. BellSouth SPA) service to which the parameters are applicable. These two-letter codes are shown preceding in parentheses following the category of Special Access (a.k.a. BellSouth SPA) service. The number "1" following the two-letter code indicates the technical specifications package for a customized service. An alphanumeric designation following the two-letter code indicates the specific predefined package. When appropriate, the Technical Reference which contains detailed specifications for the parameters is shown following the matrix.

Channel interfaces at each point of termination on a two-point service may be symmetrical or asymmetrical. On a multipoint service they may also be symmetrical or asymmetrical. However, communications can only be provided between points of termination with compatible channel interfaces. Only certain channel interfaces are compatible. These are set forth in a combination format.

Only certain channel interface combinations are available with the predefined technical specifications packages. These are delineated in the Technical References set forth at the end of this E7.2.

The optional features and functions available with each type of Special Access (a.k.a. BellSouth SPA) service are described in this section. The optional features and functions information also indicates with which technical specifications packages they are available. Such information is displayed in a matrix with the optional feature or function listed down the left side and the technical specifications package listed across the top.

Note 1: Effective June 30, 2021, this Service will no longer be available for purchase by new or existing customers. In addition, requests to move, add, change, or renew existing service arrangements will not be accepted. Following the expiration of a customer's existing term agreement, service will be provided on a month-to-month basis at the applicable Monthly rates until the service is discontinued. The Company currently plans to discontinue this service on or after June 30, 2024.

(N)
|
(N)

BELLSOUTH
 TELECOMMUNICATIONS
 ALABAMA
 ISSUED: May 28, 2021
 BY: President - Alabama
 Birmingham, Alabama

ACCESS SERVICES TARIFF

Eleventh Revised Page 8
 Cancels Tenth Revised Page 8

EFFECTIVE: June 30, 2021

E7. SPECIAL ACCESS (A.K.A. BELLSOUTH SPA) SERVICE

E7.2 Service Description (Cont'd)

All services installed after the effective date of this Tariff will conform to the transmission specification standards contained in this Tariff or in the following Technical References for each category of service:

Voice Grade (a.k.a. BellSouth SPA DSO VG) ¹	TR-NPL-000335 PUB 41004, Table 4	(C)
Digital Data Access (a.k.a. BellSouth SPA DSO Digital Data) ¹	TR-NPL-000341	(C)
For 2.4, 4.8, 9.6 and 56.0 Kbps	BellCore PUB 62310	
For 19.2 Kbps	INC. BULLETIN CB-INC-100	
For 64.0 Kbps	AT&T PUB 62310	
High Capacity (a.k.a. BellSouth SPA High Capacity)	TA-TSY-000342	
	TR-NPL-000054	
WATS Access Line (a.k.a. BellSouth SPA WATS Line) ¹	TR-NPL-000334	(C)
(DELETED)		

E7.2.1 Reserved for Future Use

Note 1: Effective June 30, 2021, this Service will no longer be available for purchase by new or existing customers. In addition, requests to move, add, change, or renew existing service arrangements will not be accepted. Following the expiration of a customer's existing term agreement, service will be provided on a month-to-month basis at the applicable Monthly rates until the service is discontinued. The Company currently plans to discontinue this service on or after June 30, 2024.

(N)
 |
 (N)

BELLSOUTH
TELECOMMUNICATIONS
ALABAMA
ISSUED: May 28, 2021
BY: President - Alabama
Birmingham, Alabama

ACCESS SERVICES TARIFF

Fifth Revised Page 9.1
Cancels Fourth Revised Page 9.1

EFFECTIVE: June 30, 2021

E7. SPECIAL ACCESS (A.K.A. BELLSOUTH SPA) SERVICE**E7.2 Service Description (Cont'd)****E7.2.3 Voice Grade (a.k.a. BellSouth SPA DS0 VG) Service^{1, 2}**

(C)

A. Basic Channel Description

A Voice Grade (a.k.a. BellSouth SPA DS0 VG) channel is a channel which provides voice frequency transmission capability in the normal frequency range of 300 to 3000 Hz and may be terminated two-wire or four-wire. Voice Grade (a.k.a. BellSouth SPA DS0 VG) channels are provided between customer designated premises or between a customer designated premises and a Company Hub.

Voice Grade (a.k.a. BellSouth SPA DS0 VG) Channels are classified as Voice Grade/Voice or Voice Grade/Data depending on the suitability of the technical specification package requested by the customer. Voice Grade (a.k.a. BellSouth SPA DS0 VG) Technical Specification Packages 1,2,3,4,5,7,8,9,11 and 12 are suitable for Voice Grade/Voice. The Technical Specification Packages 6 and 10 are suitable for Voice Grade/Data Service.

Note 1: Effective October 14, 2017, Voice Grade (a.k.a. BellSouth SPA DSO VG) service in the Carbon Hill, Alabama Telephone Company wire center is no longer available.

Note 2: Effective June 30, 2021, this Service will no longer be available for purchase by new or existing customers. In addition, requests to move, add, change, or renew existing service arrangements will not be accepted. Following the expiration of a customer's existing term agreement, service will be provided on a month-to-month basis at the applicable Monthly rates until the service is discontinued. The Company currently plans to discontinue this service on or after June 30, 2024.

(N)

(N)

BELLSOUTH
 TELECOMMUNICATIONS
 ALABAMA
 ISSUED: May 28, 2021
 BY: President - Alabama
 Birmingham, Alabama

ACCESS SERVICES TARIFF

Fifth Revised Page 10
 Cancels Fourth Revised Page 10

EFFECTIVE: June 30, 2021

E7. SPECIAL ACCESS (A.K.A. BELLSOUTH SPA) SERVICE

E7.2 Service Description (Cont'd)

E7.2.3 Voice Grade (a.k.a. BellSouth SPA DS0 VG) Service^{1,2} (Cont'd)

(C)

B. Technical Specifications Packages

Parameter	Package VG-												
	1	2	3	4	5	6	7	8	9	10	11	12	
Attenuation Distortion	X	X	X	X	X	X	X	X	X	X	X	X	X
C-Message Noise	X	X	X	X	X	X	X	X	X	X	X	X	X
Echo Control	X	X	X		X		X	X			X	X	
Envelope Delay													
Distortion						X	X	X	X	X	X	X	X
Frequency Shift						X	X	X	X	X	X	X	X
Impulse Noise					X	X	X	X	X	X	X	X	X
Intermodulation													
Distortion						X	X	X	X	X	X	X	X
Loss Deviation	X	X	X	X	X	X	X	X	X	X	X	X	X
Phase Jitter						X	X	X	X	X	X	X	X
Signal-to-C													
Message Noise				X									
Signal-to-C													
Notch Noise					X	X	X	X	X	X	X	X	X

The technical specifications for these parameters are delineated in Technical Reference TR-NPL-000335 and associated Addendum.

Note 1: Effective October 14, 2017, Voice Grade (a.k.a. BellSouth SPA DSO VG) service in the Carbon Hill, Alabama Telephone Company wire center is no longer available.

Note 2: Effective June 30, 2021, this Service will no longer be available for purchase by new or existing customers. In addition, requests to move, add, change, or renew existing service arrangements will not be accepted. Following the expiration of a customer's existing term agreement, service will be provided on a month-to-month basis at the applicable Monthly rates until the service is discontinued. The Company currently plans to discontinue this service on or after June 30, 2024.

(N)

(N)

BELLSOUTH
TELECOMMUNICATIONS
ALABAMA
ISSUED: May 28, 2021
BY: President - Alabama
Birmingham, Alabama

ACCESS SERVICES TARIFF

Eighth Revised Page 11
Cancels Seventh Revised Page 11

EFFECTIVE: June 30, 2021

E7. SPECIAL ACCESS (A.K.A. BELLSOUTH SPA) SERVICE**E7.2 Service Description (Cont'd)****E7.2.3 Voice Grade (a.k.a. BellSouth SPA DS0 VG) Service^{4, 5} (Cont'd)**

(C)

C. Channel Interfaces

The following channel interfaces for Voice Grade (a.k.a. BellSouth SPA DS0 VG) service do not require signaling capability: DA, DB, DD, DE, DS, NO, PR and TF.

The following channel interfaces for Voice Grade (a.k.a. BellSouth SPA DS0 VG) service require signaling capability: AB, AC, CT, DX, EA, EB, EC, EX, GO, GS, LA, LB, LC, LO, LR, LS, RV and SF.

Compatible channel interfaces are set forth in Technical Reference TR-NPL-000054-A and associated addendum following.

D. Optional Features and Functions

1. Central Office Bridging Capability
 - a. Voice Bridging (two-wire and four-wire)¹
 - b. Data Bridging (two-wire and four-wire)²
 - c. Telephoto Bridging (two-wire and four-wire)³
 - d. Telemetry and Alarm Bridging
 - Split Band, Active Bridging

2. Conditioning

Conditioning provides more specific transmission characteristics for Voice Grade (a.k.a. BellSouth SPA DS0 VG) services. C-Type conditioning controls attenuation distortion and envelope delay distortion. Sealing Current helps maintain continuity on dry metallic⁵ loops.

In addition, a customer may desire that either the attenuation distortion or the envelope delay distortion, or both, be improved to more stringent specifications than those provided for C-Type conditioning. In such cases the customer has the option of ordering either Improved Attenuation Distortion or Improved Envelope Delay Distortion, or both, as desired.

For two-point services, the parameters apply to each service. For multipoint services, the parameters apply to each mid link or end link. C-Type conditioning and D-conditioning may be combined on the same service.

(C)

Note 1: Voice Bridging is intended for use with VG2, 5 and 12. However, it may be used on VG6 and VG10 at a customers request.

Note 2: Data Bridging is intended for use with VG6 and VG10. However, it may be used on VG2, 5 and 12 at a customers request.

Note 3: Telephoto Bridging is intended for use on VG11.

Note 4: Effective October 14, 2017, Voice Grade (a.k.a. BellSouth SPA DSO VG) service in the Carbon Hill, Alabama Telephone Company wire center is no longer available.

Note 5: Effective June 30, 2021, this Service will no longer be available for purchase by new or existing customers. In addition, requests to move, add, change, or renew existing service arrangements will not be accepted. Following the expiration of a customer's existing term agreement, service will be provided on a month-to-month basis at the applicable Monthly rates until the service is discontinued. The Company currently plans to discontinue this service on or after June 30, 2024.

(N)

(N)

BELLSOUTH
 TELECOMMUNICATIONS
 ALABAMA
 ISSUED: May 28, 2021
 BY: President - Alabama
 Birmingham, Alabama

ACCESS SERVICES TARIFF

Seventh Revised Page 12
 Cancels Sixth Revised Page 12

EFFECTIVE: June 30, 2021

E7. SPECIAL ACCESS (A.K.A. BELLSOUTH SPA) SERVICE

E7.2 Service Description (Cont'd)

E7.2.3 Voice Grade (a.k.a. BellSouth SPA DS0 VG) Service^{1,2} (Cont'd)

(C)

D. Optional Features and Functions (Cont'd)

2. Conditioning (Cont'd)

a. C-Type Conditioning

C-Type Conditioning is provided for the additional control of attenuation distortion and envelope delay distortion on data services. The attenuation distortion and envelope delay distortion specifications for C-Type Conditioning are:

Attenuation Distortion (Frequency Response) Relative to 1004 Hz

Frequency Range (Hz)	Variation (dB)
504 - 2804	-1.0 to + 3.0
304 - 3004	-2.0 to +6.0

Envelope Delay Distortion

Frequency Range (Hz)	Variation (micro-seconds)
1004 - 2604	Less Than 501
604 - 2604	Less Than 1501
504 - 2804	Less Than 3001

b. Improved Attenuation Distortion

Improved attenuation distortion is provided for additional control of attenuation distortion. The improved attenuation distortion specifications are:

Attenuation Distortion (Frequency Response) Relative to 1004 Hz

Frequency Range (Hz)	Variation (dB)
404-2804	-1.0 to +2.0
304-3004	-1.0 to +3.0
3004-3204	-2.0 to +6.0

Note 1: Effective October 14, 2017, Voice Grade (a.k.a. BellSouth SPA DSO VG) service in the Carbon Hill, Alabama Telephone Company wire center is no longer available.

Note 2: Effective June 30, 2021, this Service will no longer be available for purchase by new or existing customers. In addition, requests to move, add, change, or renew existing service arrangements will not be accepted. Following the expiration of a customer's existing term agreement, service will be provided on a month-to-month basis at the applicable Monthly rates until the service is discontinued. The Company currently plans to discontinue this service on or after June 30, 2024.

(N)
 |
 (N)

BELLSOUTH
 TELECOMMUNICATIONS
 ALABAMA
 ISSUED: May 28, 2021
 BY: President - Alabama
 Birmingham, Alabama

ACCESS SERVICES TARIFF

Sixth Revised Page 12.1
 Cancels Fifth Revised Page 12.1

EFFECTIVE: June 30, 2021

E7. SPECIAL ACCESS (A.K.A. BELLSOUTH SPA) SERVICE

E7.2 Service Description (Cont'd)

E7.2.3 Voice Grade (a.k.a. BellSouth SPA DS0 VG) Service^{1, 2} (Cont'd)

(C)

D. Optional Features and Functions (Cont'd)

2. Conditioning (Cont'd)

c. Improved Envelope Delay Distortion

Improved envelope delay distortion is provided for additional control of envelope distortion. The improved envelope delay distortion specifications are:

Envelope Delay Distortion

Frequency Range (Hz)	Variation (micro-seconds)
1001-2604	Less Than 101
604-2604	Less Than 301
504-2804	Less Than 3001

d. Sealing Current Conditioning

Sealing Current Conditioning is provided to help maintain continuity on dry metallic² loops. It is usually associated with four-wire DA or NO type channel interfaces.

(C)

3. Customer Specified Premises Receive Level

This option allows the customer to specify the receive level at the Point of Termination. The level must be within a specific range of effective four-wire transmission. The ranges are delineated in Technical Reference TR-NPL-000335.

Note 1: Effective October 14, 2017, Voice Grade (a.k.a. BellSouth SPA DSO VG) service in the Carbon Hill, Alabama Telephone Company wire center is no longer available.

Note 2: Effective June 30, 2021, this Service will no longer be available for purchase by new or existing customers. In addition, requests to move, add, change, or renew existing service arrangements will not be accepted. Following the expiration of a customer's existing term agreement, service will be provided on a month-to-month basis at the applicable Monthly rates until the service is discontinued. The Company currently plans to discontinue this service on or after June 30, 2024.

(N)

(N)

BELLSOUTH
TELECOMMUNICATIONS
ALABAMA
ISSUED: May 28, 2021
BY: President - Alabama
Birmingham, Alabama

ACCESS SERVICES TARIFF

Seventh Revised Page 13
Cancels Sixth Revised Page 13

EFFECTIVE: June 30, 2021

E7. SPECIAL ACCESS (A.K.A. BELLSOUTH SPA) SERVICE**E7.2 Service Description (Cont'd)****E7.2.3 Voice Grade (a.k.a. BellSouth SPA DS0 VG) Service^{1,2} (Cont'd)**

(C)

D. Optional Features and Functions (Cont'd)

4. Echo Control

a. ELEPL 2 ((Equal Level Echo Path Loss)

On Effective Two-Wire Transmission at Four-Wire Point of Termination (applicable to each two-wire port): Provides for a fixed 600 ohm impedance, variable level range and simplex reversal. Company equipment is required at the customer's premises where this option is ordered. Improved Return Loss parameters are delineated in Technical Reference TR-NPL-000335.

b. Improved Return Loss

On Effective Two-Wire Transmission at Two -Wire Point of Termination: provides for more stringent Echo Control specifications. In order for this option to be applicable, the transmission path must be two-wire at one Point of Termination (POT) and two-wire at the other POT. Placement of Company equipment may be required at the customer's premises with two-wire POT. The Improved Return Loss parameters are delineated in Technical Reference TR-NPL-000335.

5. D-Conditioning

D-Conditioning provides transmission characteristics suitable for data communications. Specifically, D-Conditioning provides for the control of Signal to C-Notched Noise Ratio and intermodulation distortion. It is available for two-point services or multipoint services.

The signal to C-Notched Noise Ratio and intermodulation distortion parameters for D-Conditioning are:

- Signal to C-Notched Noise Ratio is equal to or greater than 32dB
- Intermodulation distortion:
 - Signal to second order modulation products (R2) is equal to or greater than 38dB
 - Signal to third order modulation products (R3) is equal to or greater than 42dB

When a service equipped with D-Conditioning is used for voice communications, the quality of the voice transmission may not be satisfactory. D-Conditioning Transmission characteristics are described in Technical Reference TR-NPL-000335 under the name Data Capability.

6. Telephoto Conditioning

Telephoto Conditioning provides transmission characteristics suitable for telephotographic communications. Specifically, Telephoto Conditioning is provided for the control of attenuation distortion and envelope delay distortion on Telephotographic services. The attenuation distortion and envelope delay distortion parameters for telephoto conditioning are:

Note 1: Effective October 14, 2017, Voice Grade (a.k.a. BellSouth SPA DSO VG) service in the Carbon Hill, Alabama Telephone Company wire center is no longer available.

Note 2: Effective June 30, 2021, this Service will no longer be available for purchase by new or existing customers. In addition, requests to move, add, change, or renew existing service arrangements will not be accepted. Following the expiration of a customer's existing term agreement, service will be provided on a month-to-month basis at the applicable Monthly rates until the service is discontinued. The Company currently plans to discontinue this service on or after June 30, 2024.

(N)

(N)

BELLSOUTH
 TELECOMMUNICATIONS
 ALABAMA
 ISSUED: May 28, 2021
 BY: President - Alabama
 Birmingham, Alabama

ACCESS SERVICES TARIFF

Sixth Revised Page 13.1
 Cancels Fifth Revised Page 13.1

EFFECTIVE: June 30, 2021

E7. SPECIAL ACCESS (A.K.A. BELLSOUTH SPA) SERVICE

E7.2 Service Description (Cont'd)

E7.2.3 Voice Grade (a.k.a. BellSouth SPA DS0 VG) Service^{1,2} (Cont'd)

(C)

D. Optional Features and Functions (Cont'd)

6. Telephoto Conditioning (Cont'd)

**Attenuation Distortion
 (1004 Hz Reference)**

Frequency Range (Hz)	Variation (dB)
500 - 3000	- 0.5 to + 1.5

300 - 3200	- 1.0 to + 2.5
------------	----------------

Envelope Delay Distortion

Frequency Range (Hz)	Variation (mcs)
1000 - 2600	Less Than 111
800 - 2800	Less Than 181

7. Signaling Capability

Signaling Capability provides for the process by which one customer premises alerts another customer premises on the same service with which it wishes to communicate.

Note 1: Effective October 14, 2017, Voice Grade (a.k.a. BellSouth SPA DSO VG) service in the Carbon Hill, Alabama Telephone Company wire center is no longer available.

Note 2: Effective June 30, 2021, this Service will no longer be available for purchase by new or existing customers. In addition, requests to move, add, change, or renew existing service arrangements will not be accepted. Following the expiration of a customer's existing term agreement, service will be provided on a month-to-month basis at the applicable Monthly rates until the service is discontinued. The Company currently plans to discontinue this service on or after June 30, 2024.

(N)

(N)

BELLSOUTH
TELECOMMUNICATIONS
ALABAMA
ISSUED: May 28, 2021
BY: President - Alabama
Birmingham, Alabama

ACCESS SERVICES TARIFF

Tenth Revised Page 14
Cancels Ninth Revised Page 14

EFFECTIVE: June 30, 2021

E7. SPECIAL ACCESS (A.K.A. BELLSOUTH SPA) SERVICE**E7.2 Service Description (Cont'd)****E7.2.3 Voice Grade (a.k.a. BellSouth SPA DS0 VG) Service^{1, 2} (Cont'd)**

(C)

D. Optional Features and Functions (Cont'd)

8. Improved Termination

The Improved Termination option provides a fixed 600 ohm impedance, a variable level range and simplex reversal, when applicable, at the point of termination. Company equipment is required at the customer's premises when this option is ordered. The Improved Termination parameters are delineated in Technical Reference TR-NPL-000335.

9. Simplex Reversal

The Simplex Reversal option physically turns over the simplex DC path presented at the four-wire point of termination when LO, LS, GO, GS, & DX signaling is provided at the point of termination.

10. BellSouth Customer Network Management Service

BellSouth Customer Network Management Service provides the customer the ability to monitor and reconfigure Voice Grade (a.k.a. BellSouth SPA DS0 VG) service provided by the Company. BellSouth Customer Network Management Service is described in E7.4.12 following. Charges for this feature are contained in E7.5.16 following.

Note 1: Effective October 14, 2017, Voice Grade (a.k.a. BellSouth SPA DS0 VG) service in the Carbon Hill, Alabama Telephone Company wire center is no longer available.

Note 2: Effective June 30, 2021, this Service will no longer be available for purchase by new or existing customers. In addition, requests to move, add, change, or renew existing service arrangements will not be accepted. Following the expiration of a customer's existing term agreement, service will be provided on a month-to-month basis at the applicable Monthly rates until the service is discontinued. The Company currently plans to discontinue this service on or after June 30, 2024.

(N)

(N)

BELLSOUTH
 TELECOMMUNICATIONS
 ALABAMA
 ISSUED: May 28, 2021
 BY: President - Alabama
 Birmingham, Alabama

ACCESS SERVICES TARIFF

Eighth Revised Page 15
 Cancels Seventh Revised Page 15

EFFECTIVE: June 30, 2021

E7. SPECIAL ACCESS (A.K.A. BELLSOUTH SPA) SERVICE

E7.2 Service Description (Cont'd)

E7.2.3 Voice Grade (a.k.a. BellSouth SPA DS0 VG) Service^{1,2} (Cont'd)

(C)

D. Optional Features and Functions (Cont'd)

The following table shows the technical specifications packages with which the optional features and functions are available.

	Available with Technical Specifications Package VG-											
	1	2	3	4	5	6	7	8	9	10	11	12
C-Type Conditioning					X	X	X	X	X	X		
Improved Attenuation Distortion					X	X	X	X	X	X		
Improved Envelope Delay Distortion					X	X	X	X	X	X		
Sealing Current Conditioning					X	X						
D-Conditioning						X	X			X		
Central Office Bridging Capability			X		X	X				X	X	X
Customer Specified Premises Receive Level			X	X			X	X	X			
Echo Control Improved Return Loss			X	X			X					
ELEPL2	X	X	X		X		X					
BellSouth Customer Network Management Service	X	X	X	X	X	X	X	X	X	X	X	X
Improved Termination	X	X	X	X	X	X	X	X	X	X	X	X
Simplex Reversal	X	X	X				X	X	X			
Signaling Capability	X	X	X				X	X	X			
Telephoto Conditioning										X		

Note 1: Effective October 14, 2017, Voice Grade (a.k.a. BellSouth SPA DSO VG) service in the Carbon Hill, Alabama Telephone Company wire center is no longer available.

Note 2: Effective June 30, 2021, this Service will no longer be available for purchase by new or existing customers. In addition, requests to move, add, change, or renew existing service arrangements will not be accepted. Following the expiration of a customer's existing term agreement, service will be provided on a month-to-month basis at the applicable Monthly rates until the service is discontinued. The Company currently plans to discontinue this service on or after June 30, 2024.

(N)
 |
 (N)

BELLSOUTH
TELECOMMUNICATIONS
ALABAMA
ISSUED: May 28, 2021
BY: President - Alabama
Birmingham, Alabama

ACCESS SERVICES TARIFF

Seventh Revised Page 16
Cancels Sixth Revised Page 16

EFFECTIVE: June 30, 2021

E7. SPECIAL ACCESS (A.K.A. BELLSOUTH SPA) SERVICE**E7.2 Service Description (Cont'd)****E7.2.3 Voice Grade (a.k.a. BellSouth SPA DS0 VG) Service^{1,2} (Cont'd)**

(C)

E. Four-Wire/Two-Wire Conversions

When a customer requests that an effective four-wire channel be terminated with a two-wire channel interface at the customer designated premises, a four-wire to two-wire conversion is required. The rate for the conversion is included as part of the basic Local Channel rate.

F. WATS Access Line (WAL) (a.k.a. BellSouth SPA WATS Line)² service

(C)

1. Basic Channel Description

A WATS Access Line (a.k.a. BellSouth SPA WATS Line) service (WAL) provides a channel for voice frequency transmission capability. The service provides a connection between a customer designated premises and a WATS serving office associated with the closed end of BellSouth SWA 8XX Toll Free Dialing Ten Digit Screening Service, WATS (a.k.a. BellSouth SPA WATS Line) or similar services. It is provided for use with BellSouth SWA FGD in the originating and terminating direction and BellSouth SWA FGA or BellSouth SWA FGB in the terminating direction and BellSouth SWA service arrangement features as set forth in Section E6. preceding. The Company is currently unable to provide originating WATS (a.k.a. BellSouth SPA WATS Line) service through BellSouth SWA FGA or BellSouth SWA FGB. Such service will be provided as specified in 2. and 3. following.

The following shall apply to the Company's provision of WATS Access Line (a.k.a. BellSouth SPA WATS Line) service:

- a. When the end user's serving wire center is not a WATS serving office, channel mileage charges will apply for a WATS access line (a.k.a. BellSouth SPA WATS Line) extension (WALE) between the end user's serving wire center and the nearest WATS serving office.
- b. When a customer, other than AT&T, orders originating WATS Access Line (a.k.a. BellSouth SPA WATS Line) service and the end user's serving wire center is a WATS serving office which is not equipped with equal access, the Company will provide the WAL service to the nearest equal access WATS serving office by use of a WALE and the channel mileage charges for the WALE will be waived.
- c. When a customer other than AT&T orders originating WATS Access Line (a.k.a. BellSouth SPA WATS Line) service and the end user's serving wire center is not a WATS serving office and the nearest WATS (serving office is not equipped with equal access, channel mileage charges for a WALE to the nearest WATS(serving office will apply, as indicated in 1. preceding, but the Company will provide an additional WALE to the nearest WATS serving office equipped with equal access and the channel mileage charge for the additional WALE will be waived.

WATS Access Line (a.k.a. BellSouth SPA WATS Line) service is arranged for either originating calling or terminating calling. It is provided with either rotary dial or dual tone multifrequency address signaling and either loop start, ground start, E & M or reverse battery supervisory signaling. The choice of the type of signaling is at the option of the customer and subject to the technical limitations identified in the Technical Reference TR-NPL-000334. WATS Access Line (a.k.a. BellSouth SPA WATS Line) service is provided as an effective two-wire, an effective four-wire or a DS1 (i.e., 1.544 Mbps) transmission path. The DS1 WAL is only available as a trunk side termination on suitably equipped electronic switch, e.g., 1/1A ESS with Digital Carrier Termination (DCT) or DMS-100 with a Line Trunk Unit (LTU).

Note 1: Effective October 14, 2017, Voice Grade (a.k.a. BellSouth SPA DSO VG) service in the Carbon Hill, Alabama Telephone Company wire center is no longer available.

Note 2: Effective June 30, 2021, this Service will no longer be available for purchase by new or existing customers. In addition, requests to move, add, change, or renew existing service arrangements will not be accepted. Following the expiration of a customer's existing term agreement, service will be provided on a month-to-month basis at the applicable Monthly rates until the service is discontinued. The Company currently plans to discontinue this service on or after June 30, 2024.

(N)

(N)

BELLSOUTH
 TELECOMMUNICATIONS
 ALABAMA
 ISSUED: May 28, 2021
 BY: President - Alabama
 Birmingham, Alabama

ACCESS SERVICES TARIFF

Seventh Revised Page 16.1
 Cancels Sixth Revised Page 16.1

EFFECTIVE: June 30, 2021

E7. SPECIAL ACCESS (A.K.A. BELLSOUTH SPA) SERVICE

E7.2 Service Description (Cont'd)

E7.2.3 Voice Grade (a.k.a. BellSouth SPA DS0 VG) Service^{1, 2} (Cont'd)

(C)

F. WATS Access Line (WAL) (a.k.a. BellSouth SPA WATS Line)² service (Cont'd)

(C)

2. Technical Specification Packages

Parameters	Package WAL -		
	1	2	3
Attenuation Distortion	X	X	
Bit error rate			X
C-Message Noise	X	X	
Echo Control	X	X	
Envelope Delay Distortion	X	X	
Frequency Shift	X	X	
Impulse Noise	X	X	
Intermodulation Distortion	X	X	
Loss Deviation	X	X	
Phase Jitter	X	X	
Signal-to-C Notch Noise	X	X	

The technical specifications are delineated in Technical Reference TR-NPL-000334.

3. The following interfaces are available with WAL Service:

LO, LS, DS, GO, GS, RV, EA, EB

Compatible channel interfaces are set forth in Technical Reference TR-NPL-000334

4. Optional Features and Functions

- a. Two-wire and four-wire Central Office bridging capability.
- b. Improved two-wire voice transmission specifications.
- c. Certain other options associated with WAL services such as WATS (a.k.a. BellSouth SPA WATS Line) Access Line Nonchargeable Termination Options and Common Switching Optional Features are available as defined in Section E6. preceding.
- d. One-way or Two-way Capability

E7.2.4 Reserved for Future Use

Note 1: Effective October 14, 2017, Voice Grade (a.k.a. BellSouth SPA DSO VG) service in the Carbon Hill, Alabama Telephone Company wire center is no longer available.

(C)
(C)

Note 2: Effective June 30, 2021, this Service will no longer be available for purchase by new or existing customers. In addition, requests to move, add, change, or renew existing service arrangements will not be accepted. Following the expiration of a customer's existing term agreement, service will be provided on a month-to-month basis at the applicable Monthly rates until the service is discontinued. The Company currently plans to discontinue this service on or after June 30, 2024.

(N)
|
(N)

BELLSOUTH
TELECOMMUNICATIONS
ALABAMA

ACCESS SERVICES TARIFF

Fifth Revised Page 20
Cancels Fourth Revised Page 20

ISSUED: May 28, 2021
BY: President - Alabama
Birmingham, Alabama

EFFECTIVE: June 30, 2021

E7. SPECIAL ACCESS (A.K.A. BELLSOUTH SPA) SERVICE

E7.2 Service Description (Cont'd)

E7.2.7 Digital Data Access (a.k.a. BellSouth SPA DS0 Digital Data)¹ Service

(C)

A. Basic Channel Description

A Digital Data (*a.k.a. BellSouth SPA DS0 Digital Data*) channel is a channel for duplex four-wire transmission of synchronous serial data at the rate of 2.4, 4.8, 9.6, 19.2, 56 or 64 Kbps. The actual bit rate is a function of the channel interface selected by the customer. The channel provides a synchronous service with timing provided by the Company through the Company's facilities to the customer in the received bit stream. Digital Data (*a.k.a. BellSouth SPA DS0 Digital Data*) channels are only available via Company designated Digital Data (*a.k.a. BellSouth SPA DS0 Digital Data*) Hubs and are provided between customer designated premises or between a customer designated premises and a Company Digital Data (*a.k.a. BellSouth SPA DS0 Digital Data*) Hub.

A Hub termination charge applies per Digital Local Channel. This rate element covers the Hub functions (e.g., timing, testing) for the service.

Secondary Channel Capability (SCC) is a derived companion digital transmission path that is independent of the primary data path and operates at a substantially lower bit rate. This derived channel allows the customer to perform network management functions during the normal operation of the network. This diagnostics channel utilizes a portion of a customer's previously unavailable data bit stream allowing for the ability to remotely control and test the network and peripheral devices without taking the network out of service. Special customer equipment is necessary to utilize the benefits of the Secondary Channel. Customers not wishing to utilize this capability will not be impacted. Due to transmission equipment restrictions, Secondary Channel cannot be provided on 56 Kbps circuits that require the installation of loop repeater equipment for provision of service. Secondary Channel Capability, also, cannot be provided on 64 Kbps circuits, since all of the available bit stream will be used by the customer.

Note 1: Effective June 30, 2021, this Service will no longer be available for purchase by new or existing customers. In addition, requests to move, add, change, or renew existing service arrangements will not be accepted. Following the expiration of a customer's existing term agreement, service will be provided on a month-to-month basis at the applicable Monthly rates until the service is discontinued. The Company currently plans to discontinue this service on or after June 30, 2024.

(N)
|
(N)

BELLSOUTH
 TELECOMMUNICATIONS
 ALABAMA
 ISSUED: May 28, 2021
 BY: President - Alabama
 Birmingham, Alabama

ACCESS SERVICES TARIFF

Tenth Revised Page 21
 Cancels Ninth Revised Page 21

EFFECTIVE: June 30, 2021

E7. SPECIAL ACCESS (A.K.A. BELLSOUTH SPA) SERVICE

E7.2 Service Description (Cont'd)

E7.2.7 Digital Data Access (a.k.a. BellSouth SPA DS0 Digital Data)³ Service (Cont'd)

(C)

A. Basic Channel Description (Cont'd)

The customer will provide the Channel Service Unit-type equipment or other Network Channel Terminating Equipment associated with the Digital Data (a.k.a. BellSouth SPA DS0 Digital Data) channel at the customer premises. The interim program for interconnection of such equipment is set forth in Technical Reference PUB AS No. 1.

B. Technical Specifications Packages

Parameter	Package DA-					
	1	2	3	4	5	6
Error-Free Seconds	X	X	X	X	X	X

The Company will provide a channel capable of meeting a monthly average performance equal to or greater than 99.875 percent error-free seconds¹ while the channel is in service, if it is measured through a CSU equivalent, which is designed, manufactured, and maintained to conform with the interconnection specifications contained in Technical Reference PUB 62310.

Interface options and service objectives for Digital Data Access (a.k.a. BellSouth SPA DS0 Digital Data) service are delineated in Technical Reference TR-NPL-000341.

C. Channel Interfaces

The following channel interfaces (CIs) define the bit rates that are available for a Digital Data (a.k.a. BellSouth SPA DS0 Digital Data) channel:

CI	Bit Rate
DU-24(S) ²	2.4 Kbps
DU-48(S) ²	4.8 Kbps
DU-96(S) ²	9.6 Kbps
DU-19(S) ²	19.2 Kbps
DU-56(S) ²	56.0 Kbps
DU-64	64.0 Kbps

Compatible channel interfaces are set forth in Technical Reference TR-NPL-000-341

D. Optional Features and Functions

1. Central Office Bridging Capability
2. Secondary Channel Capability
3. ***BellSouth Customer Network Management Service***

BellSouth Customer Network Management Service provides the customer the ability to monitor and reconfigure Digital Data Access (a.k.a. BellSouth SPA DS0 Digital Data) service provided by the Company. ***BellSouth Customer Network Management Service*** is described in E7.4.12 following. Charges for this feature are contained in E7.5.16 following.

- Note 1:** This channel performance does not apply when the Data Over Voice Channel option is used.
- Note 2:** (S) is an additional BellSouth designation for use when the optional Secondary Channel feature is required.
- Note 3:** Effective June 30, 2021, this Service will no longer be available for purchase by new or existing customers. In addition, requests to move, add, change, or renew existing service arrangements will not be accepted. Following the expiration of a customer's existing term agreement, service will be provided on a month-to-month basis at the applicable Monthly rates until the service is discontinued. The Company currently plans to discontinue this service on or after June 30, 2024.

(N)
 |
 (N)

BELLSOUTH
 TELECOMMUNICATIONS
 ALABAMA
 ISSUED: May 28, 2021
 BY: President - Alabama
 Birmingham, Alabama

ACCESS SERVICES TARIFF

Fifth Revised Page 21.1
 Cancels Fourth Revised Page 21.1

EFFECTIVE: June 30, 2021

E7. SPECIAL ACCESS (A.K.A. BELLSOUTH SPA) SERVICE

E7.2 Service Description (Cont'd)

E7.2.7 Digital Data Access (a.k.a. BellSouth SPA DS0 Digital Data)¹ Service (Cont'd)

(C)

D. Optional Features and Functions (Cont'd)

4.

The following table shows the technical specifications packages with which the optional features and functions are available.

	Available with Technical Specifications Package DA-					
	1	2	3	4	5	6
Central Office Bridging Capability	X	X	X	X	X	
Secondary Channel Capability	X	X	X	X	X	
<i>BellSouth Customer Network Management Service</i>	X	X	X	X	X	X

Note 1: Effective June 30, 2021, this Service will no longer be available for purchase by new or existing customers. In addition, requests to move, add, change, or renew existing service arrangements will not be accepted. Following the expiration of a customer's existing term agreement, service will be provided on a month-to-month basis at the applicable Monthly rates until the service is discontinued. The Company currently plans to discontinue this service on or after June 30, 2024.

(N)

(N)

BELLSOUTH
 TELECOMMUNICATIONS
 ALABAMA
 ISSUED: May 28, 2021
 BY: President - Alabama
 Birmingham, Alabama

ACCESS SERVICES TARIFF

Eighth Revised Page 22
 Cancels Seventh Revised Page 22

EFFECTIVE: June 30, 2021

E7. SPECIAL ACCESS (A.K.A. BELLSOUTH SPA) SERVICE

E7.2 Service Description (Cont'd)

E7.2.8 High Capacity (a.k.a. BellSouth SPA High Capacity) Service

A. Basic Channel Description

A High Capacity (*a.k.a. BellSouth SPA High Capacity*) channel is a channel for the transmission of nominal 64.0 Kbps^{1, 3} or 1.544, 3.152, 6.312, or 44.736 Mbps isochronous serial data. The actual bit rate is a function of the channel interface selected by the customer. High Capacity (*a.k.a. BellSouth SPA High Capacity*) channels are provided between customer designated premises or between a customer designated premises and a Company Hub. (C)

The customer will provide the Network Channel Terminating Equipment associated with the High Capacity (*a.k.a. BellSouth SPA High Capacity*) channel at the customer's premises. The interim program for interconnection of such equipment is set forth in Technical Reference PUB AS No. 1.

B. Technical Specifications Packages

Parameters	Package HC-		
	0	1	1C 2 3
Error-Free Seconds		X	

A channel with technical specifications package HC1 will be capable of an error-free second performance of 98.75 percent over a continuous 24 hour period as measured at the 1.544 Mbps rate through a CSU equivalent which is designed, manufactured and maintained to conform with the interconnection specifications contained in TR-NPL-000054

Further technical specifications are delineated in Technical Reference TA-TSY-000342.

C. Channel Interfaces

The following channel interfaces (CIs) define the bit rates that are available for a High Capacity (*a.k.a. BellSouth SPA High Capacity*) channel:

CI	Bit Rate
DS-15 ^{2, 3}	1.544 Mbps (DS1)
DS-31	3.152 Mbps (DS1C)
DS-44	44.736 Mbps (DS3)
DS-63	6.312 Mbps (DS2)

Compatible channel interfaces are set forth in Technical Reference TA-TSY-000342.

Note 1: Available only as a cross connect (through connection) of two 2.4, 4.8, 9.6, 19.2, 56.0 or 64.0 Kbps channels of two 1.544 Mbps facilities to a Digital Data (*a.k.a. BellSouth SPA DS0 Digital Data*) Hub(s). The customer must provide system and channel assignment data.

Note 2: A 64.0 Kbps channel is available as a channel(s) of a 1.544 Mbps facility to a Company Hub.

Note 3: Effective June 30, 2021, 64.0 Kbps will no longer be available for purchase by new or existing customers. In addition, requests to move, add, change, or renew existing service arrangements will not be accepted. Following the expiration of a customer's existing term agreement, service will be provided on a month-to-month basis at the applicable Monthly rates until the service is discontinued. The Company currently plans to discontinue this service on or after June 30, 2024.

(C)

(C)

(N)

(N)

BELLSOUTH
TELECOMMUNICATIONS
ALABAMA
ISSUED: May 28, 2021
BY: President - Alabama
Birmingham, Alabama

ACCESS SERVICES TARIFF

Eighth Revised Page 23.1
Cancels Seventh Revised Page 23.1

EFFECTIVE: June 30, 2021

E7. SPECIAL ACCESS (A.K.A. BELLSOUTH SPA) SERVICE**E7.2 Service Description (Cont'd)****E7.2.8 High Capacity (a.k.a. BellSouth SPA High Capacity) Service (Cont'd)****D. Optional Features and Functions (Cont'd)**

3. Channelization

a. DS3 to DS1

An arrangement that channelizes a 44.736 Mbps channel to twenty-eight DS1 channels.

b. DS2 to DS1

An arrangement that channelizes a 6.312 Mbps channel to four DS1 channels.

c. DS1C to DS1

An arrangement that channelizes a 3.152 Mbps channel to two DS1 channels.

d. DS1 Basic Channelization System

An arrangement that channelizes a 1.544 Mbps channel to a maximum of twenty-four 64.0 Kbps channels that may be used to activate both analog and digital services, e.g., voice grade and digital data access service. A Basic Channelization System requires a Central Office Channel Interface for each channel of lesser capacity.

e. DS0 Basic Channelization System¹

An arrangement that channelizes a 64.0 Kbps channel to subspeeds of up to twenty 2.4 Kbps, ten 4.8 Kbps, or five 9.6 Kbps channels. A Basic Channelization System requires a Central Office Channel Interface for each channel of lesser capacity.

(C)

4. Channel Interface

a. DS1 Level Central Office Channel Interface

An arrangement for the connection of DS1 (1.544 Mbps) channels to higher order DS3 (44.736 Mbps) services in Company central office locations.

b. DS1 Level Customer Channel Interface

An arrangement for the connection of DS1 (1.544 Mbps) channels to higher order DS3 (44.736 Mbps) services at customer locations.

c. DS0 Level Central Office Channel Interface¹

An arrangement for the connection of VG/DS0 (2.4-64.0 Kbps) channels to higher order DS1 (1.544 Mbps) services in Company central office locations.

(C)

d. Subrate Level Central Office Channel Interface¹

An arrangement for the connection of subrate (2.4-9.6 Kbps) channels to higher order DS0 (64.0 Kbps) services in Company central office locations.

(C)

5. ***BellSouth Customer Network Management Service***

BellSouth Customer Network Management Service provides the customer the ability to monitor and reconfigure High Capacity (a.k.a. BellSouth SPA High Capacity) service provided by the Company. ***BellSouth Customer Network Management Service*** is described in E7.4.12 following. Charges for this feature are contained in E7.5.16 following.

Note 1: Effective June 30, 2021, this Service will no longer be available for purchase by new or existing customers. In addition, requests to move, add, change, or renew existing service arrangements will not be accepted. Following the expiration of a customer's existing term agreement, service will be provided on a month-to-month basis at the applicable Monthly rates until the service is discontinued. The Company currently plans to discontinue this service on or after June 30, 2024.

(N)

(N)

BELLSOUTH
 TELECOMMUNICATIONS
 ALABAMA
 ISSUED: May 28, 2021
 BY: President - Alabama
 Birmingham, Alabama

ACCESS SERVICES TARIFF

Sixteenth Revised Page 24
 Cancels Fifteenth Revised Page 24

EFFECTIVE: June 30, 2021

E7. SPECIAL ACCESS (A.K.A. BELLSOUTH SPA) SERVICE

E7.2 Service Description (Cont'd)

E7.2.8 High Capacity (a.k.a. BellSouth SPA High Capacity) Service (Cont'd)

D. Optional Features and Functions (Cont'd)

The following table shows the technical specifications packages with which the optional features and functions are available.

	Available With Technical Specifications Package HC-				
	0	1	1C	2	3
Channelization:					
DS3 to DS1					X
DS2 to DS1				X	
DS1C to DS1			X		
DS1 Basic Channelization System		X			
DS0 Basic Channelization System ^{1, 2}	X				(C)
Clear Channel Capability		X			
<i>BellSouth Customer Network Management Service</i>	X	X			

E7.2.9 Reserved for Future Use

E7.2.10 Reserved for Future Use

E7.2.11 Reserved for Future Use

E7.2.12 Reserved for Future Use

E7.2.13 Reserved for Future Use

E7.2.14 Reserved for Future Use

Note 1: Available only on 64.0 Kbps DDAS (a.k.a. BellSouth SPA DS0 Digital Data) service or on a DS1 (1.544 Mbps) (a.k.a. BellSouth SPA DS1) channel with Clear Channel Capability to a Company Hub.

Note 2: Effective June 30, 2021, this Service will no longer be available for purchase by new or existing customers. In addition, requests to move, add, change, or renew existing service arrangements will not be accepted. Following the expiration of a customer's existing term agreement, service will be provided on a month-to-month basis at the applicable Monthly rates until the service is discontinued. The Company currently plans to discontinue this service on or after June 30, 2024.

(N)
 |
 (N)

BELLSOUTH
TELECOMMUNICATIONS
ALABAMA
ISSUED: May 28, 2021
BY: President - Alabama
Birmingham, Alabama

ACCESS SERVICES TARIFF

Third Revised Page 24.3
Cancels Second Revised Page 24.3

EFFECTIVE: June 30, 2021

E7. SPECIAL ACCESS (A.K.A. BELLSOUTH SPA) SERVICE**E7.3 Channel Interface And Network Channel Codes**

This section explains the Channel Interface codes and Network Channel codes that the customer must specify when ordering Special Access (*a.k.a. BellSouth SPA*) service. Included is an example which explains the specific characters of the code, a glossary of Channel Interface codes, impedance levels, Network Channel codes and compatible Channel Interfaces.

Example: If the customer specifies a NT Network Channel Code and a 2DC8-3 Channel Interface at the customer's premises, the following is being requested:

NT = Metallic Channel¹ with a Predefined Technical Specification Package (1) (C)

2 = Number of physical¹ wires at customer premises (T)

DC = Facility interface for direct current or voltage

8 = Variable impedance level

3 = Metallic facilities¹ (DC continuity) for direct current/low frequency control signals or slow signals or slow speed data (30 baud) (C)

E7.3.1 Glossary Of Channel Interface Codes And Options

Code - Option	Definition
AB -	Accepts 20 Hz ringing signal at customer's point of termination
AC -	Accepts 20 Hz ringing signal at the customer's end user's point of termination
CS -	Digital hierarchy interface at Digital Crossconnect System (DCS)
- EA	E & M Signaling
- GO	Ground Start Loop Signaling-Open End
- GS	Ground Start Loop Signaling-Closed End
- LO	Loop Start Loop Signaling-Open End
- LS	Loop Start Loop Signaling-Closed End
- NO	Transmission Only - No Signaling
- R	(DS0)Customer Reconfigurable Voice Grade (a.k.a. BellSouth SPA DSO VG) ¹ service (C)
- 10R	DS1 to DS0 Customer Reconfigurable ¹
- 10	DS1 to DS0 ¹ (C)
- 11R	DS1 to DS1 Customer Reconfigurable
- 11	DS1 to DS1
- SP	Resistive Type: Split Path Operation for Data Polling Conference Type
- CF	Resistive Type: Split Path Operation for Symmetrical Voice Conference Type
- BC	CO Bridging: Broadcast for Broadcast Conference Type

Note 1: Effective June 30, 2021, this Service will no longer be available for purchase by new or existing customers. In addition, requests to move, add, change, or renew existing service arrangements will not be accepted. Following the expiration of a customer's existing term agreement, service will be provided on a month-to-month basis at the applicable Monthly rates until the service is discontinued. The Company currently plans to discontinue this service on or after June 30, 2024. (N)

BELLSOUTH
TELECOMMUNICATIONS
ALABAMA
ISSUED: May 28, 2021
BY: President - Alabama
Birmingham, Alabama

ACCESS SERVICES TARIFF

Seventh Revised Page 25
Cancels Sixth Revised Page 25

EFFECTIVE: June 30, 2021

E7. SPECIAL ACCESS (A.K.A. BELLSOUTH SPA) SERVICE**E7.3 Channel Interface And Network Channel Codes (Cont'd)****E7.3.1 Glossary Of Channel Interface Codes And Options (Cont'd)**

Code - Option (DELETED)	Definition	
DA -	Data stream in VF frequency band at customer's end user's point of termination	
DB -	Data stream in VF frequency band at customer's point of termination	
- 10	VF for TG1 and TG2	
- 43	VF for 43 Telegraph ¹ Carrier type signals, TG1 and TG2	(C)
DC -	Direct current or voltage	
- 1	Monitoring interface with series RC combination (McCulloh format)	
- 2	Company energized alarm channel	
- 3	Metallic ¹ facilities (DC continuity) for direct current/low frequency control signals or slow speed data (30 baud)	(C)
DS -	Digital hierarchy interface	
- 1K	1.544 Mbps (DS1) ANSI Extended Superframe (ESF) format per TA-TSY-000342	
- 1S	1.544 Mbps (DS1) ANSI Extended Superframe (ESF) format and B8ZS Clear Channel Capability per TA-TSY-000342.	
- 15	1.544 Mbps (DS1) Superframe (SF) format per TA-TSY-000342	
- 15B	1.544 Mbps (DS1) Superframe (SF) format and B8ZS Clear Channel Capability per TA-TSY-000342	
- 15E	8-bit PCM encoded in one 64 Kbps of the DS1 signal	
- 15F	8-bit PCM encoded in two 64 Kbps of the DS1 signal	
- 15G	8-bit PCM encoded in three 64 Kbps of the DS1 signal	
- 15H	14/11-bit PCM encoded in six 64 Kbps of the DS1 signal	
- 15J	1.544 Mbps format per PUB 41451 (only available to U.S. Govt. agencies)	
- 31	3.152 Mbps (DS1C)	
- 31L	3.152 Mbps (DS1C) with SF signaling	
- 44	44.736 Mbps (DS3)	

Note 1: Effective June 30, 2021, this Service will no longer be available for purchase by new or existing customers. In addition, requests to move, add, change, or renew existing service arrangements will not be accepted. Following the expiration of a customer's existing term agreement, service will be provided on a month-to-month basis at the applicable Monthly rates until the service is discontinued. The Company currently plans to discontinue this service on or after June 30, 2024.

(N)

(N)

BELLSOUTH
 TELECOMMUNICATIONS
 ALABAMA
 ISSUED: May 28, 2021
 BY: President - Alabama
 Birmingham, Alabama

ACCESS SERVICES TARIFF

Eighth Revised Page 26
 Cancels Seventh Revised Page 26

EFFECTIVE: June 30, 2021

E7. SPECIAL ACCESS (A.K.A. BELLSOUTH SPA) SERVICE

E7.3 Channel Interface And Network Channel Codes (Cont'd)

E7.3.1 Glossary Of Channel Interface Codes And Options (Cont'd)

Code - Option	Definition
- 44L	44.736 Mbps (DS3) with SF signaling
- 63	6.312 Mbps (DS2)
- 63L	6.312 Mbps (DS2) with SF signaling
DU -	Digital access interface
- 19(S) ¹	19.2 Kbps ²
- 24(S) ¹	2.4 Kbps ²
- 48(S) ¹	4.8 Kbps ²
- 56(S) ¹	56.0 Kbps ²
- 64	64.0 Kbps ²
- 96(S) ¹	9.6 Kbps ²
- 1KN	DS1 (1.544 Mbps) ANSI Extended Superframe (ESF) Format per TR-NPL-000054 without line power
- 1SN	DS1 (1.544 Mbps) ANSI Extended Superframe (ESF) Format per TR-NPL-000054, with B8ZS Clear Channel Capability and without line power
- A	DS1 (1.544 Mbps) free-framing format per PUB 41451 with line power (only available to U. S. Govt. agencies)
- AN	DS1 (1.544 Mbps) free-framing format per PUB 41451 without line power (only available to U. S. Govt. agencies)
- BN	DS1 (1.544 Mbps) Superframe (SF) Format per TR-NPL-000054 without line power
- DN	DS1 (1.544 Mbps) Superframe (SF) Format per TR-NPL-000054, with B8ZS Clear Channel Capability and without line power.
- SN	1.544 Mbps (DS1) ANSI Extended Superframe (ESF) format and B8ZS Clear Channel Capability
DV -	Data and Voice Multiplexing
- BC	Digital Data Over Voice, 9.6 Kbps ²
DX -	Duplex signaling interface at customer's point of termination
EA - E	Type I, E&M Lead Signaling. Customer at POT or customer's end user at POT originates one E Lead.
EA - M	Type I E&M Lead Signaling. Customer at POT or customer's end user at POT originates on M Lead.
EB - E	Type II, E&M Lead Signaling. Customer at POT or customer's end user at POT originates on E Lead.
EB - M	Type II E&M Lead Signaling. Customer at POT or customer's end user at POT originates on M Lead.
EC -	Type III, E&M signaling at customer POT.

Note 1: (S) is an additional BellSouth designation for use when the optional Secondary Channel feature is required.

Note 2: Effective June 30, 2021, this Service will no longer be available for purchase by new or existing customers. In addition, requests to move, add, change, or renew existing service arrangements will not be accepted. Following the expiration of a customer's existing term agreement, service will be provided on a month-to-month basis at the applicable Monthly rates until the service is discontinued. The Company currently plans to discontinue this service on or after June 30, 2024.

(C)

(C)

(N)

BELLSOUTH
 TELECOMMUNICATIONS
 ALABAMA
 ISSUED: May 28, 2021
 BY: President - Alabama
 Birmingham, Alabama

ACCESS SERVICES TARIFF

Fourth Revised Page 27
 Cancels Third Revised Page 27

EFFECTIVE: June 30, 2021

E7. SPECIAL ACCESS (A.K.A. BELLSOUTH SPA) SERVICE

E7.3 Channel Interface And Network Channel Codes (Cont'd)

E7.3.1 Glossary Of Channel Interface Codes And Options (Cont'd)

Code - Option	Definition	
LA -	End user loop start loop signaling - Type A OPS registered port open end	
LB -	End user loop start loop signaling - Type B OPS registered port open end	
LC -	End user loop start loop signaling - Type C OPS registered port open end	
LO -	Loop start loop signaling - open end function by customer or customer's end user	
LR -	20 Hz automatic ringdown interface at customer with Company provided PLAR	
LS -	Loop start loop signaling - closed end function by customer or customer's end user	
- M	For terminating in central office located answering service concentrator	
NO -	No signaling interface, transmission only	
PG -	Program transmission - no dc signaling	
- 3	Nominal frequency from 200 to 3,500 Hz	
- 5	Nominal frequency from 100 to 5,000 Hz	
- 8	Nominal frequency from 50 to 8,000 Hz	
PR -	Protective relaying ¹	
RV - O	Reverse battery signaling, one way operation, originate by customer	
- T	Reverse battery signaling, one way operation, terminate function by customer or customer's end user	
SF -	Single frequency signaling with VF band at either customer POT or customer's end user POT	
TF -	Telephotograph ² interface	(C)
TT -	Telegraph ² /teletypewriter interface at either customer POT or customer's end user POT	(C)
- 2	20.0 milliamperes	
- 3	3.0 milliamperes	
- 6	62.5 milliamperes	

Note 1: Available only for the transmission of audio tone protective relaying signals used in the protection of electric power systems during fault conditions.

Note 2: Effective June 30, 2021, this Service will no longer be available for purchase by new or existing customers. In addition, requests to move, add, change, or renew existing service arrangements will not be accepted. Following the expiration of a customer's existing term agreement, service will be provided on a month-to-month basis at the applicable Monthly rates until the service is discontinued. The Company currently plans to discontinue this service on or after June 30, 2024.

(N)
 |
 (N)

BELLSOUTH
 TELECOMMUNICATIONS
 ALABAMA
 ISSUED: May 28, 2021
 BY: President - Alabama
 Birmingham, Alabama

ACCESS SERVICES TARIFF

Sixteenth Revised Page 49.1
 Cancels Fifteenth Revised Page 49.1

EFFECTIVE: June 30, 2021

E7. SPECIAL ACCESS (A.K.A. BELLSOUTH SPA) SERVICE**E7.4 Rate Regulations**

This section contains the specific regulations governing the rates and charges that apply for Special Access (a.k.a. BellSouth SPA) service.

E7.4.1 Types Of Rates And Charges

- A. There are two types of rates and charges. These are monthly rates and nonrecurring charges. The rates and charges are described as follows:

1. Monthly Rates

Monthly rates are flat recurring rates that apply each month or fraction thereof that a Special Access (a.k.a. BellSouth SPA) service is provided. For billing purposes, each month is considered to have 30 days.

Digital Data Access (a.k.a. BellSouth SPA DS0 Digital Data)³ service is offered under two contract plans. Contract plan rates are available in payment periods from twenty-four to forty-two months² and in payment periods from forty-three to sixty months² under conditions specified in the Channel Services Payment Plan in E2.4 of this Tariff. (These payment periods are an exception to those listed in E2.4 of this Tariff.) Termination Liability charges will not apply for customer requests for moves of service under CSPP subject to the provisions set forth in E2.4.9.A.11. of this Tariff. However, Termination Liability Charge is applicable at the date of termination if the customer terminates or disconnects the service prior to fulfilling the period of the contract plan except as specified in b. following. The Termination Liability Charge is **fifty percent (50%) of the following**: the contracted monthly rate times the number of months in the contract plan, less the contracted monthly rate times the number of months the service has been installed. An example is provided in a. following. (C)

The following list identifies the individual Special Access (a.k.a. BellSouth SPA) services provided under Section E7. of this Tariff which are eligible for credit of nonrecurring charges under "Service Installation Guarantee" found in E2.4.10 of this Tariff. Customers with these services are not eligible for the Service Installation Guarantee when the requested installation, move or rearrangement service order interval is four days or less as measured from the Application Date of the order.

- Voice Grade (a.k.a. BellSouth SPA DS0 VG)³, (C)

- Digital Data Access (a.k.a. BellSouth SPA DS0 Digital Data) service^{1,3}, (C)

- High Capacity (a.k.a. BellSouth SPA High Capacity) service

- SMARTRing service (a.k.a. BellSouth Dedicated Ring)

Provided, however, that the following services are not eligible for such credit.

- BellSouth Customer Network Management Service

- BellSouth Metro Ethernet service

- a. A customer subscribes to Digital Data Access (a.k.a. BellSouth SPA DS0 Digital Data)³ service using the twenty-four to forty-two month payment plan. The contract plan period is for thirty months. The subscriber terminates the service after twelve months. The total liability charge is thirty months times the monthly rate. The amount is then reduced to reflect the number of months the subscriber has had the service, which in this example is twelve months. Therefore, the Termination Liability Charge is calculated as follows: (C)

$$\text{Termination Liability Charge} = .50 \times [(30 \text{ months} \times \text{monthly rate}) - (12 \text{ months} \times \text{monthly rate})]$$

Note 1: The Data Over Voice Channel optional feature is not eligible for such credit.

Note 2: Effective November 9th, 2013, customers may not establish new term plans greater than 36 months for Digital Data Access and term plans may not be renewed for a term greater than 36 months.

Note 3: Effective June 30, 2021, this Service will no longer be available for purchase by new or existing customers. In addition, requests to move, add, change, or renew existing service arrangements will not be accepted. Following the expiration of a customer's existing term agreement, service will be provided on a month-to-month basis at the applicable Monthly rates until the service is discontinued. The Company currently plans to discontinue this service on or after June 30, 2024. (N)

BELLSOUTH
 TELECOMMUNICATIONS
 ALABAMA
 ISSUED: May 28, 2021
 BY: President - Alabama
 Birmingham, Alabama

ACCESS SERVICES TARIFF

Tenth Revised Page 50.1
 Cancels Ninth Revised Page 50.1

EFFECTIVE: June 30, 2021

E7. SPECIAL ACCESS (A.K.A. BELLSOUTH SPA) SERVICE

E7.4 Rate Regulations (Cont'd)

E7.4.1 Types Of Rates And Charges (Cont'd)

A. (Cont'd)

3. Nonrecurring Charges (Cont'd)

a. Installation of Service

Nonrecurring charges apply to each Service installed. When one service is ordered and installed, it is billed at the First Service Installed rate. When more than one of the same type of service, between the same locations, for the same customer is ordered and installed at the same time, one at each location is billed at the First Service Installed Rate and the others are billed at the Additional Service Installed rate.

b. Installation of Optional Features and Functions

Nonrecurring charges apply for the installation of some of the optional features and functions available with Special Access (a.k.a. BellSouth SPA) service. The Initial nonrecurring charge applies if the feature or function is installed coincident with the primary service. The Subsequent nonrecurring charge applies if the feature or function is installed after the installation of the primary service.

One nonrecurring charge is applicable to bridging.

The nonrecurring charges for the installation of optional features and functions are set forth in E7.5 following as nonrecurring charges for optional features and functions associated with the specific services.

First and Additional nonrecurring charges are applicable to activate each individual Central Office Channel Interface of a DS1 or DS0 Basic Channelization System¹ and are in addition to the nonrecurring charges for the DS1 or DS0 Basic Channelization System¹. A "First" Central Office Channel Interface nonrecurring charge is applicable to the first Central Office Channel Interface installed coincident with the installation of a DS1 or DS0 Basic Channelization System¹, per service request. The "Additional" nonrecurring charge applies for each additional Central Office Channel Interface, of the same type, ordered and installed at the same location, for the same customer, at the same time, on the same order request. Future requests for a Central Office Channel Interface on an existing DS1 or DS0 Basic Channelization System¹ will be treated as new requests and will require "First" and "Additional" Central Office Channel Interface nonrecurring charge application in addition to any other applicable charges.

One nonrecurring charge is applicable for each individual DS1 level central office or customer channel interface, and is in addition to any other applicable charge(s).

The nonrecurring charges for the installation of optional features and functions are set forth in E7.5 following as nonrecurring charges for optional features and functions associated with the specific services.

4. Service Rearrangements

Service rearrangements are changes to existing (installed) services which do not result in either a change in the minimum period requirements as set forth in E5.2.5.E. preceding or a change in the physical location of the point of the termination at a customer designated premises. Changes which result in the establishment of new minimum period obligations are treated as disconnects and starts. Changes in the physical location of the point of the termination are treated as moves and are described and charged for as set forth in E7.4.5 following. A change which results from a transfer of service is described and charged as set forth in 4. and E7.5.13 following.

The charge to the customer for the service rearrangement is dependent on whether the change is administrative only in nature or involves actual physical change to the service.

Note 1: Effective June 30, 2021, this Service will no longer be available for purchase by new or existing customers. In addition, requests to move, add, change, or renew existing service arrangements will not be accepted. Following the expiration of a customer's existing term agreement, service will be provided on a month-to-month basis at the applicable Monthly rates until the service is discontinued. The Company currently plans to discontinue this service on or after June 30, 2024.

(C)
 |
 (C)

(C)

(M)
 (M)

(N)
 |
 (N)

E7. SPECIAL ACCESS (A.K.A. BELLSOUTH SPA) SERVICE

E7.4 Rate Regulations (Cont'd)

E7.4.1 Types Of Rates And Charges (Cont'd)

A. (Cont'd)

4. Service Rearrangements (Cont'd)

Administrative changes, identified as follows, will be made without charge(s) to the customer. Such changes require the continued provision and billing of the Access service to the same entity (i.e., customer remains responsible for all outstanding indebtedness for the Access service. Administrative changes are as follows:

- Change of customer name (i.e., the customer of record does not change but rather the customer of record changes its name -- e.g., AT&T-Long Lines to AT&T-Communications),
- Change of customer or customer's end user premises address when the change of address is not a result of a physical relocation of equipment,
- Change in billing data (name, address, or contact name or telephone number, the customer of record does not change),
- Change of customer circuit identification,
- Change of billing account number,
- Change of customer test line number,
- Change of customer or customer's end user contact name or telephone number, and
- Change of jurisdiction.

All other service rearrangements, including physical changes to existing services, will be charges for as follows:

- If the change involves the addition of other customer designated premises to an existing multipoint service, the nonrecurring charge for the Local channel rate element will apply. The charge(s) will apply only for the location(s) that is being added. (M1)
- If the change involves the addition of optional features or functions which have separate nonrecurring charges, the nonrecurring charges for the optional features or functions added will apply. (M1)
- If the change involves changing the type of signaling on a Voice Grade (a.k.a. BellSouth SPA DS0 VG)¹ service, a charge equal to the Voice Grade (a.k.a. BellSouth SPA DS0 VG)¹ Local channel rate element nonrecurring charge will apply. The charge will apply per service termination affected. (C)
- If the change involves a customer requested change of data transmission rate for an existing Digital Data Access (a.k.a. BellSouth SPA DS0 Digital Data)¹ Service circuit, the appropriate nonrecurring charge shall be the Speed Change Charge provided in E7.5.5.C.4. This charge shall apply per local channel on each circuit where the speed is requested to be changed. The existing circuit will experience out of service time when the speed change work is conducted. (Full nonrecurring charges shall apply for customer requests for changes of data transmission rate where out of service time cannot be tolerated. The customer shall specify the disconnect date for the circuit being replaced.) (C)
- If the change involves changing (reconfiguring) an existing BellSouth Metro Ethernet service Connection, appropriate charges provided in E7.4.32 apply.
- If the change involves the addition of a DS3 Network Interface Unit (NIU) to a SMARTRing service (a.k.a. BellSouth SPA Dedicated Ring) the rates and charges shown in E13.3.25.
- For all other changes, including a change of the customer of record involving no physical changes to the service provided or the addition of optional features without separate nonrecurring charges, a charge equal to a Local channel rate element nonrecurring charge will apply. Only one such charge will apply per service, per change.

5. Transfer of Service

When a change in billing data (e.g., name, address, contact name, or telephone number) is requested in association with a change in the customer of record, transfer of service charges, as set forth in E7.5.13 will apply. Charges are applied on a Billing Account Number (BAN) and per circuit basis.

Note 1: Effective June 30, 2021, this Service will no longer be available for purchase by new or existing customers. In addition, requests to move, add, change, or renew existing service arrangements will not be accepted. Following the expiration of a customer's existing term agreement, service will be provided on a month-to-month basis at the applicable Monthly rates until the service is discontinued. The Company currently plans to discontinue this service on or after June 30, 2024.

M1 Material appearing on this page previously appeared on page 50.1 of this section.
 M2 Material previously appearing on this page now appears on page 51.1 of this section.

BELLSOUTH
TELECOMMUNICATIONS
ALABAMA
ISSUED: May 28, 2021
BY: President - Alabama
Birmingham, Alabama

ACCESS SERVICES TARIFF

Second Revised Page 51.1
Cancels First Revised Page 51.1

EFFECTIVE: June 30, 2021

E7. SPECIAL ACCESS (A.K.A. BELLSOUTH SPA) SERVICE**E7.4 Rate Regulations (Cont'd)****E7.4.2 Surcharge For Special Access (a.k.a. BellSouth SPA) service****A. General**

In addition to the rates and charges described in E7.4.1, there is a monthly surcharge that applies to Special Access (a.k.a. BellSouth SPA) service. The Special Access (a.k.a. BellSouth SPA) Surcharge compensates the Company for use of the local exchange network when Special Access (a.k.a. BellSouth SPA) service is connected to a PBX or equivalent device which is capable of interconnecting the Special Access (a.k.a. BellSouth SPA) service with local exchange service.

The Company will automatically bill the surcharge on each Special Access (a.k.a. BellSouth SPA) service installed irrespective of whether the interconnection capability exists in the customer's premises equipment or in a Centrex Type Services switch unless written certification is received for the customer certifying exemption status as set forth in E7.4.2.B.

(M)

(M)

B. Special Access (a.k.a. BellSouth SPA) Surcharge Exemptions

The Special Access (a.k.a. BellSouth SPA) service will be exempted from the surcharge if the customer provides the Company written certification that the Special Access (a.k.a. BellSouth SPA) service termination is one of the following:

1. An open-end termination in a Company switch on an FX line, including CCSA and CCSA-equivalent ONALS; or
2. an analog Local channel that is used for radio or television program transmission; or
3. a termination used for TELEX service; or

BELLSOUTH
TELECOMMUNICATIONS
ALABAMA
ISSUED: May 28, 2021
BY: President - Alabama
Birmingham, Alabama

ACCESS SERVICES TARIFF

Eleventh Revised Page 55
Cancels Tenth Revised Page 55

EFFECTIVE: June 30, 2021

E7. SPECIAL ACCESS (A.K.A. BELLSOUTH SPA) SERVICE**E7.4 Rate Regulations (Cont'd)****E7.4.7 Facility Hubs**

A customer has the option of ordering analog or digital high capacity (a.k.a. BellSouth SPA High Capacity) facilities (i.e., DS1, DS1C, DS2, or DS3) to a facility Hub for channelizing to individual services requiring lower capacity facilities (e.g., Voice (a.k.a. BellSouth SPA DS0 VG)¹, etc.).

Different locations may be designated as Hubs for different facility capacities, e.g., channelization from digital to digital may occur at one location while channelization from digital to analog may occur at a different location. When ordering, the customer will specify the desired channelization Hub(s) selected from the National Exchange Carrier Association Tariff F.C.C. No. 4. This tariff identifies the type(s) of channelization functions which are available and the serving wire centers at which they are available.

Some of the types of channelization available include the following:

- from higher to lower bit rate
- from digital to voice frequency channels

End to end services may be provided on channels of these facilities to a hub. The transmission performance for the end to end service provided between customer designated premises will be that of the lower capacity or bit rate. For example, when a 1.544 Mbps facility is channelized to voice frequency channels, the transmission performance of the channelized services will be Voice Grade (a.k.a. BellSouth SPA DS0 VG)¹, not High Capacity (a.k.a. BellSouth SPA High Capacity).

The Company will commence billing the monthly rate for the facility to the Hub on the date specified by the customer on the service order. Individual services utilizing these facilities may be installed coincident with the installation of the facility to the Hub or may be ordered and/or installed at a later date, at the option of the customer. The customer will be billed for a Voice Grade (a.k.a. BellSouth SPA DS0 VG)¹ or a digital Local Channel, Interoffice Channel, if applicable and the Basic Channelization System at the time the facility is installed. DS1 and DS0 Basic Channelization Systems¹ require a Central Office Channel Interface for activation of each lesser capacity channel. DS3 to DS1 channelization arrangements, for transport of intrastate high capacity DS1 (a.k.a. BellSouth SPA DS1) service channels via LightGate[®] service (a.k.a. BellSouth SPA Point to Point Network) and SMARTRing[®] services (a.k.a. BellSouth SPA Dedicated Ring), require a DS1 channel interface for activation of each DS1 channel. Individual service rates (by service type) will apply for a Local channel and additional interoffice channels and Central Office Channel Interface(s) (as required) for each channelized service. These will be billed to the customer as each individual service is installed.

Cascading channelization occurs when a high capacity analog or digital channel is channelized to provide channels with a lesser capacity and one of the lesser capacity channels is further channelized.

When cascading channelization is performed, whether in the same or a different Hub, a charge for the additional Basic Channelization System and Central Office Channel Interface(s) also applies. A DS1 Basic Channelization System and DDAS¹ Central Office Channel Interface are required for high speed or low speed activations when channelized from a DS1 (1.544 Mbps) channel. A DS0 Basic Channelization System¹ and Subrate Central Office Channel Interface¹ are required for subrate¹ activations of 2.4, 4.8 and 9.6 when channelized from a DS0 (64 Kbps)¹ channel. When cascading channelization is performed at different Hubbing locations, interoffice channel charges also apply between the Hubs.

E7.4.8 Shared Use Analog And Digital High Capacity (a.k.a. BellSouth SPA High Capacity) Services

Shared use occurs when Special Access (a.k.a. BellSouth SPA) service and BellSouth SWA are provided over the same High Capacity (a.k.a. BellSouth SPA High Capacity) Facility through a common interface. When the customer orders Special Access (a.k.a. BellSouth SPA) service, the facility will be ordered and rated as Special Access (a.k.a. BellSouth SPA) service (i.e., Local channel *or VirtualCollocation Cross-Connect*, interoffice channel, as appropriate, and Basic Channelization System if applicable) until such time as the customer chooses to use a portion of the available capacity for providing (a.k.a. BellSouth SPA) service. As each individual channel is activated for BellSouth SWA, the Special Access (a.k.a. BellSouth SPA) Local channel rates and interoffice channel rates will be reduced accordingly (e.g., 1/24th for a DS1 service, etc.). The customer must place an order for each individual BellSouth SWA Channel provided over Special Access (a.k.a. BellSouth SPA) service utilizing the Shared Use Facilities and specify the channel assignment for each such service.

Note 1: Effective June 30, 2021, this Service will no longer be available for purchase by new or existing customers. In addition, requests to move, add, change, or renew existing service arrangements will not be accepted. Following the expiration of a customer's existing term agreement, service will be provided on a month-to-month basis at the applicable Monthly rates until the service is discontinued. The Company currently plans to discontinue this service on or after June 30, 2024.

BELLSOUTH
 TELECOMMUNICATIONS
 ALABAMA
 ISSUED: May 28, 2021
 BY: President - Alabama
 Birmingham, Alabama

ACCESS SERVICES TARIFF

Twelfth Revised Page 56
 Cancels Eleventh Revised Page 56

EFFECTIVE: June 30, 2021

E7. SPECIAL ACCESS (A.K.A. BELLSOUTH SPA) SERVICE

E7.4 Rate Regulations (Cont'd)

E7.4.8 Shared Use Analog And Digital High Capacity (a.k.a. BellSouth SPA High Capacity) Services (Cont'd)

BellSouth SWA and WATS Access Line (a.k.a. BellSouth SPA WATS Line)¹ service rates and charges as set forth in E6.8 preceding will apply for each channel of the shared use facility that is used to provide BellSouth SWA or WATS Access Line (a.k.a. BellSouth SPA WATS Line)¹ service. Where Special Access (a.k.a. BellSouth SPA) service is provided utilizing a channel (s) of the shared use facility to the Hub, High Capacity (a.k.a. BellSouth SPA High Capacity) rates and charges will apply for the facility to the hub as set forth preceding and individual service rates and charges will apply from the hub to the customer designated premises. The rates and charges that will apply to the portion from the hub to the customer-designated premises will be dependent on the specific type of Special Access (a.k.a. BellSouth SPA) service that is provided (e.g., Voice Grade (a.k.a. BellSouth SPA DS0 VG)¹, etc.). The applicable rates and charges will include a local channel and interoffice channel, and appropriate channelization elements if applicable. The applicable rates for WATS Access Lines (a.k.a. BellSouth SPA WATS Line)¹ will be the WATS Access Line (a.k.a. BellSouth SPA WATS Line)¹ Transport rates set forth in E6.8.5 preceding, if applicable. Rates and charges for optional features and functions associated with the service, if any, will apply as set forth in E7.5 following.

Access Collocation Cross-Connects provide a means for customers to interconnect their BellSouth Shared Use and Digital High Capacity (a.k.a. BellSouth SPA High Capacity) services to Central Office Collocation arrangements within the same Central Office. Terms, conditions, and rates for Physical Access Collocation Cross-Connects and Virtual Access Collocation Cross-Connects are set forth in Section E13. of this Tariff.

The capability exists for a customer to utilize all or part of a SMARTRing service (a.k.a. BellSouth Dedicated Ring) to transport switched access provided the SMARTRing service (a.k.a. BellSouth Dedicated Ring) channel interface transporting the BellSouth SWA service does not have *BellSouth Customer Network Management Service* capability. The customer must place an order for each individual BellSouth SWA Channel provided over Dedicated Access service Shared Use Facilities and specify the channel assignment for each such service. The switched traffic would enter and exit the SMARTRing service (a.k.a. BellSouth Dedicated Ring) at Customer and Central Office Nodes on that network. When this occurs, ratcheting of Dedicated Access rate elements (i.e. Nodes, Channel Interfaces, Local Channels, Alternate Central Office Channels, Internodal Channels, or Interoffice Channels) will be based on the number of voice grade (a.k.a. BellSouth SPA DS0 VG)¹ equivalent trunks/lines of that rate element used for BellSouth SWA access.

Reduction factors will be developed to reduce the charges on system level billing as well as the billing on individual DS1, DS3, STS-1, OC-3, and/or OC-12 Channel Interfaces. For ratcheting purposes, the system level charges include Customer Nodes, Central Office Nodes, Local Channels, Alternate Central Office Channels, Internodal Channels, and Interoffice Channels as appropriate to make up a customer's SMARTRing service (a.k.a. BellSouth Dedicated Ring). Individual OC-1, OC-3 and OC-12 Channel Interfaces used in Overlay Ring Arrangements will be ratcheted as system level charges. The system reduction factor will apply to the system level charges.

The system reduction factor will be derived by dividing the number of activated BellSouth SWA access circuits by the voice grade (a.k.a. BellSouth SPA DS0 VG)¹ channel equivalent capacity of the self-healing ring. An OC-1 SMARTRing service (a.k.a. BellSouth Dedicated Ring) has 672 voice grade (a.k.a. BellSouth SPA DS0 VG)¹ equivalent channels. An OC-3 SMARTRing service (a.k.a. BellSouth Dedicated Ring) has 2,016 voice grade (a.k.a. BellSouth SPA DS0 VG)¹ equivalent channels. An OC-3+ or OC-12 SMARTRing service (a.k.a. BellSouth Dedicated Ring) has 8,064 voice grade¹ equivalent channels. An OC-48 SMARTRing service (a.k.a. BellSouth Dedicated Ring) or OC-48+ SMARTRing service (a.k.a. BellSouth Dedicated Ring) with 48 or less activated DS3s has 32,256 voice grade (a.k.a. BellSouth SPA DS0 VG)¹ equivalent channels. However, when an OC-48+ SMARTRing service (a.k.a. BellSouth Dedicated Ring) is used to transport BellSouth SWA service, and more than 48 equivalent DS3s are activated on the service, the factor will be based upon the actual number of activated DS3s times 672 DS0s. A factor for individual DS3 channel interfaces and 28 DS1 channel systems, will be derived by dividing the number of activated BellSouth SWA access circuits associated with the DS3 channel by the voice grade (a.k.a. BellSouth SPA DS0 VG)¹ equivalent capacity of the DS3 channel. A DS3 has 672 voice grade (a.k.a. BellSouth SPA DS0 VG)¹ equivalent channels. For DS1 channel interfaces, a factor is derived by dividing the number of BellSouth SWA access circuits associated with the DS1 channel by the voice grade (a.k.a. BellSouth SPA DS0 VG)¹ equivalent capacity of the DS1 channel, which is 24. Each reduction factor is rounded to four decimal places and then multiplied against the respective monthly charges to determine the reduction amount.

BellSouth SWA rates and charges as set forth in E6.8 preceding will apply for each channel of the shared use facility that is used to provide BellSouth SWA.

Note 1: Effective June 30, 2021, this Service will no longer be available for purchase by new or existing customers. In addition, requests to move, add, change, or renew existing service arrangements will not be accepted. Following the expiration of a customer's existing term agreement, service will be provided on a month-to-month basis at the applicable Monthly rates until the service is discontinued. The Company currently plans to discontinue this service on or after June 30, 2024.

BELLSOUTH
 TELECOMMUNICATIONS
 ALABAMA
 ISSUED: May 28, 2021
 BY: President - Alabama
 Birmingham, Alabama

ACCESS SERVICES TARIFF

Eighth Revised Page 57.1
 Cancels Seventh Revised Page 57.1

EFFECTIVE: June 30, 2021

E7. SPECIAL ACCESS (A.K.A. BELLSOUTH SPA) SERVICE

E7.5 Rates And Charges (Cont'd)

E7.5.3 Voice Grade (a.k.a. BellSouth SPA DS0 VG)³ service

(C)

A. Local Channel

- 1. Per Point of Termination
 - a. Voice Grade (a.k.a. BellSouth SPA DS0 VG)
 - (1) Voice

		Monthly Rate ²	Nonrecurring Charge		USOC
			First Service Installed ²	Additional Service Installed ²	
(a)	Two-Wire	\$45.00	\$365.00	\$119.49	T6E2X
(b)	Four-Wire	65.00	270.00	125.19	T6E4X
(2)	Data				
(a)	Two-Wire	45.00	324.00	119.49	T6E2X
(b)	Four-Wire	65.00	270.00	125.19	T6E4X
(3)	Loop Facilities Not Required ¹				
(a)	Two-Wire	14.40	156.00	87.60	EUC2N
(b)	Four-Wire	14.40	156.00	87.60	EUC4N

Note 1: For connections to Company Centrex Type Services Switches and Equipment considered to be end-user premises.

Note 2: *Rate decreases retroactive to December 27, 2004.*

Note 3: Effective June 30, 2021, this Service will no longer be available for purchase by new or existing customers. In addition, requests to move, add, change, or renew existing service arrangements will not be accepted. Following the expiration of a customer's existing term agreement, service will be provided on a month-to-month basis at the applicable Monthly rates until the service is discontinued. The Company currently plans to discontinue this service on or after June 30, 2024.

(N)

(N)

BELLSOUTH
 TELECOMMUNICATIONS
 ALABAMA
 ISSUED: May 28, 2021
 BY: President - Alabama
 Birmingham, Alabama

ACCESS SERVICES TARIFF

Eighth Revised Page 58
 Cancels Seventh Revised Page 58

EFFECTIVE: June 30, 2021

E7. SPECIAL ACCESS (A.K.A. BELLSOUTH SPA) SERVICE

E7.5 Rates And Charges (Cont'd)

E7.5.3 Voice Grade (a.k.a. BellSouth SPA DS0 VG)² service (Cont'd)

(C)

B. Interoffice Channel

1. Mileage Bands

	Fixed Monthly Charge¹	Monthly Charge Per Mile¹	Nonrecurring Charge	USOC
(a) 0 miles	\$ -	\$ -	\$ -	1L5XX
(b) 1 thru 8 miles	27.00	1.70	110.00	1L5XX
(c) 9 thru 25 miles	27.00	1.70	110.00	1L5XX
(d) Over 25 miles	27.00	1.70	110.00	1L5XX

C. Optional Features and Functions

1. Bridging

a. Voice Bridging, Two-Wire/Four-Wire

(1) Per port

	Monthly Rate¹	Nonrecurring Charge¹	USOC
(a) Two-Wire	\$ 8.00	\$52.00	BCNV2
(b) Four-Wire	10.00	52.00	BCNV4

b. Data Bridging, Two-Wire/Four-Wire

(1) Per port

(a) Two-Wire	15.00	52.00	BCND2
(b) Four-Wire	13.00	52.00	BCND4

c. Telephoto Bridging, Two-Wire/Four-Wire

(1) Per port

(a) Two-Wire	8.00	52.00	BCNF2
(b) Four-Wire	10.00	52.00	BCNF4

Note 1: Rate decreases retroactive to December 27, 2004.

Note 2: Effective June 30, 2021, this Service will no longer be available for purchase by new or existing customers. In addition, requests to move, add, change, or renew existing service arrangements will not be accepted. Following the expiration of a customer's existing term agreement, service will be provided on a month-to-month basis at the applicable Monthly rates until the service is discontinued. The Company currently plans to discontinue this service on or after June 30, 2024.

(N)
 |
 (N)

BELLSOUTH
 TELECOMMUNICATIONS
 ALABAMA
 ISSUED: May 28, 2021
 BY: President - Alabama
 Birmingham, Alabama

ACCESS SERVICES TARIFF

Sixth Revised Page 59
 Cancels Fifth Revised Page 59

EFFECTIVE: June 30, 2021

E7. SPECIAL ACCESS (A.K.A. BELLSOUTH SPA) SERVICE

E7.5 Rates And Charges (Cont'd)

E7.5.3 Voice Grade (a.k.a. BellSouth SPA DS0 VG)² service (Cont'd)

(C)

C. Optional Features and Functions (Cont'd)

1. Bridging (Cont'd)

d. DataPhone Select-A-Station Bridging -
 Primary Data Station Selector (Cont'd)

(2) Addressable Arrangement

	Monthly Rate¹	Nonrecurring Charge¹	USOC
(a) Common Equipment	<i>\$300.00</i>	<i>\$318.00</i>	DXNPA
(3) Channel Connections			
(a) Per two-wire connection	<i>6.00</i>	<i>43.20</i>	DXNP2
(b) Per four-wire connection	<i>18.00</i>	<i>49.20</i>	DXNP4

f. Telemetry and Alarm Bridging - Split Band, Active Bridging

(1) Common Equipment, per central office

(a) First bridging shelf, capacity of 48 two-wire connections	120.00	390.00	DXQC1
(b) Additional bridging shelf, capacity of 56 two-wire connections installed subsequent to the first bridging shelf	120.00	350.00	DXQC2
(c) Additional bridging shelf, capacity of 56 two-wire connections installed at the same time as the first bridging shelf	50.00	220.00	NA

Note 1: Rates are effective with normal billing cycles beginning on or after March 22, 2003.

Note 2: Effective June 30, 2021, this Service will no longer be available for purchase by new or existing customers. In addition, requests to move, add, change, or renew existing service arrangements will not be accepted. Following the expiration of a customer's existing term agreement, service will be provided on a month-to-month basis at the applicable Monthly rates until the service is discontinued. The Company currently plans to discontinue this service on or after June 30, 2024.

(N)
 |
 (N)

BELLSOUTH
 TELECOMMUNICATIONS
 ALABAMA
 ISSUED: May 28, 2021
 BY: President - Alabama
 Birmingham, Alabama

ACCESS SERVICES TARIFF

Fifth Revised Page 59.1
 Cancels Fourth Revised Page 59.1

EFFECTIVE: June 30, 2021

E7. SPECIAL ACCESS (A.K.A. BELLSOUTH SPA) SERVICE

E7.5 Rates And Charges (Cont'd)

E7.5.3 Voice Grade (a.k.a. BellSouth SPA DS0 VG)² service (Cont'd)

(C)

C. Optional Features and Functions (Cont'd)

1. Bridging (Cont'd)

f. Telemetry and Alarm Bridging - Split Band, Active Bridging (Cont'd)

(2) Channel connections, per channel connected

	Monthly Rate	Nonrecurring Charge		USOC
(a) Remote station channel connection	\$5.00	\$36.00		DXQRX
(b) Mid-link channel connection, first channel	10.00	46.00		DXQMI
(c) Mid-link channel connection, subsequent channels	10.00	46.00		DXQMS

2. Conditioning, Per Point of Termination

	Monthly Rate ¹	Nonrecurring Charge		USOC
		Initial ¹	Subsequent ¹	
(a) C-Type	\$ 3.00	\$17.41	\$110.00	X1CPT
(b) Improved Attenuation Distortion	.00	.00	186.55	UHW
(c) Improved Envelope Delay Distortion	16.00	69.05	186.55	UHY
(d) Sealing Current	.95	.00	.00	1HBPT

3. Echo Control for Effective Two-Wire Service

(1) Per Point of Termination

(a) Improved Return Loss At the Two-Wire Point of Termination	8.00	49.88	369.30	1RL2W
(b) ELEPL2 At the Four-Wire Point of Termination	20.00	32.19	120.00	UHZ

4. Customer Specified Receive Level

(a) Per two-wire Point of Termination	12.35	.00	110.00	RLS
---------------------------------------	-------	-----	--------	-----

Note 1: Rate decreases retroactive to December 27, 2004.

Note 2: Effective June 30, 2021, this Service will no longer be available for purchase by new or existing customers. In addition, requests to move, add, change, or renew existing service arrangements will not be accepted. Following the expiration of a customer's existing term agreement, service will be provided on a month-to-month basis at the applicable Monthly rates until the service is discontinued. The Company currently plans to discontinue this service on or after June 30, 2024.

(N)

(N)

BELLSOUTH
 TELECOMMUNICATIONS
 ALABAMA
 ISSUED: May 28, 2021
 BY: President - Alabama
 Birmingham, Alabama

ACCESS SERVICES TARIFF

Eighth Revised Page 60
 Cancels Seventh Revised Page 60

EFFECTIVE: June 30, 2021

E7. SPECIAL ACCESS (A.K.A. BELLSOUTH SPA)SERVICE

E7.5 Rates And Charges (Cont'd)

E7.5.3 Voice Grade (a.k.a. BellSouth SPA DS0 VG)⁶ service (Cont'd)

(C)

C. Optional Features and Functions (Cont'd)

5. D-Conditioning

	Monthly Rate ⁵	Nonrecurring Charge		USOC
		Initial ⁵	Subsequent ⁵	
6. Telephoto Conditioning				
(a) Per point of termination	\$ 1.90	\$ 5.40	357.66	XDCPT
7. Signaling Capability, per Point of Termination				
(a) Per Point of Termination	4.00	4.43	332.56	XTCPT
(b) Loop ¹	6.00	5.43	318.41	XSS++
(c) Single Frequency	7.00	15.00	318.58	XSS++
(d) E&M ²	12.00	15.00	329.97	XSS++
(e) Ground ³	6.00	5.40	306.32	XSS++
(f) Type C	3.60	19.20	312.00	XSSLC
(f) Other ⁴	12.00	5.39	316.94	XSS++
8. Improved Termination				
(a) Per Point of Termination	6.00	4.50	319.11	UGD
9. Simplex Reversal				
(a) Per Point of Termination	-	-	-	UGJ

Note 1: In lieu of ++ substitute LO or LS as appropriate.

Note 2: In lieu of ++ substitute EA, EB, EC or CT as appropriate.

Note 3: In lieu of ++ substitute GO or GS as appropriate.

Note 4: In lieu of ++ substitute LA, LB, LC, LR, RV, DX, DY, EX, AB or AC as appropriate.

Note 5: *Rate decreases retroactive to December 27, 2004.*

Note 6: Effective June 30, 2021, this Service will no longer be available for purchase by new or existing customers. In addition, requests to move, add, change, or renew existing service arrangements will not be accepted. Following the expiration of a customer's existing term agreement, service will be provided on a month-to-month basis at the applicable Monthly rates until the service is discontinued. The Company currently plans to discontinue this service on or after June 30, 2024.

(N)

(N)

BELLSOUTH
 TELECOMMUNICATIONS
 ALABAMA
 ISSUED: May 28, 2021
 BY: President - Alabama
 Birmingham, Alabama

ACCESS SERVICES TARIFF

Eighth Revised Page 60.1
 Cancels Seventh Revised Page 60.1

EFFECTIVE: June 30, 2021

E7. SPECIAL ACCESS (A.K.A. BELLSOUTH SPA) SERVICE

E7.5 Rates And Charges (Cont'd)

E7.5.3 Voice Grade (a.k.a. BellSouth SPA DS0 VG)³ service (Cont'd)

D. WATS Access Line (a.k.a. BellSouth SPA WATS Line)³

The following apply to a WATS Access Line (a.k.a. BellSouth SPA WATS Line) used for interLATA only calling. Rates for all other WATS Access Lines (a.k.a. BellSouth SPA WATS Line) (i.e., combined interLATA/intraLATA calling) are found in the Company's General Subscriber Services Tariff, Section A19.

1. Two-Wire/Four-Wire WATS Access Line (a.k.a. BellSouth SPA WATS Line)

a. Local Channel

(1) Per Point of Termination

	Monthly Rate ²	Nonrecurring Charge First Service Installed ²	Additional Service Installed ²	USOC
(a) Per Two-Wire Line	\$50.00	\$345.00	\$121.22	X2W
(b) Per Two-Wire Line ¹	50.00	345.00	121.22	X2L
(c) Per Four-Wire Line	70.00	375.00	127.87	X4W
(d) Per Four-Wire Line ¹	70.00	375.00	127.87	X4L

2. Interoffice Channel

a. Mileage Bands

(1) Rates

	Fixed Monthly Charge ²	Monthly Charge Per Mile ²	Nonrecurring Charge ²	USOC
(a) 0 miles	\$ -	\$ -	\$ -	1LFFX
(b) 1 thru 8 miles	35.00	2.00	89.00	1LFFX
(c) 9 thru 25 miles	35.00	2.00	89.00	1LFFX
(d) Over 25 miles	35.00	2.00	89.00	1LFFX

Note 1: For use with Direct Inward Dial (DID) or DID/DOD Access (a.k.a. BellSouth SPA) service with BellSouth SWA Basic Serving Arrangement for use with WATS Access Lines (a.k.a. BellSouth SPA WATS Line) described in E6.3.5.A. and provided in E6.8.3.F. of this Tariff.

Note 2: *Rate decreases retroactive to December 27, 2004.*

Note 3: Effective June 30, 2021, this Service will no longer be available for purchase by new or existing customers. In addition, requests to move, add, change, or renew existing service arrangements will not be accepted. Following the expiration of a customer's existing term agreement, service will be provided on a month-to-month basis at the applicable Monthly rates until the service is discontinued. The Company currently plans to discontinue this service on or after June 30, 2024.

(C)

(C)

(N)

(N)

BELLSOUTH
 TELECOMMUNICATIONS
 ALABAMA
 ISSUED: May 28, 2021
 BY: President - Alabama
 Birmingham, Alabama

ACCESS SERVICES TARIFF

Fifth Revised Page 60.2
 Cancels Fourth Revised Page 60.2

EFFECTIVE: June 30, 2021

E7. SPECIAL ACCESS (A.K.A. BELLSOUTH SPA) SERVICE

E7.5 Rates And Charges (Cont'd)

E7.5.3 Voice Grade (a.k.a. BellSouth SPA DS0 VG)² service (Cont'd)

(C)

D. WATS Access Line (a.k.a. BellSouth SPA WATS Line)² (Cont'd)

(C)

3. Optional Features

a. Improved Two-Wire Voice Transmission Specifications

(1) For WATS Access Line (a.k.a. BellSouth SPA WATS Line)

	Monthly Rate ¹	Nonrecurring Charge		USOC
		Initial ¹	Subsequent ¹	
(a) Two-Wire	<i>\$6.00</i>	<i>\$25.00</i>	<i>\$95.77</i>	X2T
b. WATS Access Line (a.k.a. BellSouth SPA WATS Line) Bridging				
(1) Two-Wire/Four-Wire, per port				

	Monthly Rate ¹	Nonrecurring Charge ¹	USOC
(a) Two-Wire	<i>\$ 8.00</i>	<i>\$52.00</i>	BCNV2
(b) Four-Wire	<i>10.00</i>	<i>52.00</i>	BCNV4

Note 1: *Rate decreases retroactive to December 27, 2004.*

Note 2: Effective June 30, 2021, this Service will no longer be available for purchase by new or existing customers. In addition, requests to move, add, change, or renew existing service arrangements will not be accepted. Following the expiration of a customer's existing term agreement, service will be provided on a month-to-month basis at the applicable Monthly rates until the service is discontinued. The Company currently plans to discontinue this service on or after June 30, 2024.

(N)

(N)

BELLSOUTH
 TELECOMMUNICATIONS
 ALABAMA
 ISSUED: May 28, 2021
 BY: President - Alabama
 Birmingham, Alabama

ACCESS SERVICES TARIFF

Tenth Revised Page 65.1
 Cancels Ninth Revised Page 65.1

EFFECTIVE: June 30, 2021

E7. SPECIAL ACCESS (A.K.A. BELLSOUTH SPA) SERVICE

E7.5 Rates And Charges (Cont'd)

E7.5.7 Digital Data Access (a.k.a. BellSouth SPA DS0 Digital Data)⁴ Service

(C)

A. Local Channel

1. Per Point of Termination⁷

	Nonrecurring Charge		Month	24 to	43 to	USOC
	First	Add'l	to	42	60	
			Month	Months ^{2,3}	Months ^{2,3}	
(a) 2.4 Kbps	\$421.00	\$274.00	\$71.00	\$46.25	\$44.50	T6ECS
(b) 4.8 Kbps	421.00	274.00	71.00	46.25	44.50	T6ECS
(c) 9.6 Kbps	421.00	274.00	71.00	46.25	44.50	T6ECS
(d) 19.2 Kbps	421.00	274.00	71.00	46.25	44.50	T6ECS
(e) 56.0 Kbps	491.00	324.00	97.50	57.00	54.00	T6ECS
(f) 64.0 Kbps	491.00	324.00	97.50	57.00	54.00	T6ECS

2. Hub Termination, per Local Channel

(a) 2.4 Kbps	29.00	26.00	10.00	9.75	9.50	TUTA4
(b) 4.8 Kbps	29.00	26.00	10.00	9.75	9.50	TUTB4
(c) 9.6 Kbps	29.00	26.00	10.00	9.75	9.50	TUTC4
(d) 19.2 Kbps	29.00	26.00	10.00	9.75	9.50	TUTE4
(e) 56.0 Kbps	29.00	26.00	30.00	28.00	26.00	TUTD4
(f) 64.0 Kbps	29.00	26.00	30.00	28.00	26.00	TUTF4

Note 1: Rate decreases retroactive to December 27, 2004.

Note 2: Effective November 9th, 2013, customers may not establish new term plans greater than 36 months for Digital Data Access Service and term plans may not be renewed for a term greater than 36 months.

Note 3: Effective March 24, 2019, Customers may not convert, renew or establish CSPPs for Digital Data Access Service.

Note 4: Effective June 30, 2021, this Service will no longer be available for purchase by new or existing customers. In addition, requests to move, add, change, or renew existing service arrangements will not be accepted. Following the expiration of a customer's existing term agreement, service will be provided on a month-to-month basis at the applicable Monthly rates until the service is discontinued. The Company currently plans to discontinue this service on or after June 30, 2024.

(N)

(N)

BELLSOUTH
 TELECOMMUNICATIONS
 ALABAMA
 ISSUED: May 28, 2021
 BY: President - Alabama
 Birmingham, Alabama

ACCESS SERVICES TARIFF

Sixth Revised Page 66
 Cancels Fifth Revised Page 66

EFFECTIVE: June 30, 2021

E7. SPECIAL ACCESS (A.K.A. BELLSOUTH SPA) SERVICE

E7.5 Rates And Charges (Cont'd)

E7.5.7 Digital Data Access (a.k.a. BellSouth SPA DS0 Digital Data)² Service (Cont'd)

(C)

B. Interoffice Channel

1. 2.4 Kbps

Mileage Bands¹

		Fixed Monthly Charge	Monthly Charge Per Mile	Nonrecurring Charge	USOC
(a)	0 miles	\$-	\$-	\$-	1L5XX
(b)	1 thru 8 miles	19.00	1.80	60.00	1L5XX
(c)	9 thru 25 miles	19.00	1.80	60.00	1L5XX
(d)	Over 25 miles	19.00	1.80	60.00	1L5XX

2. 4.8 Kbps

Mileage Bands¹

(a)	0 miles	-	-	-	1L5XX
(b)	1 thru 8 miles	19.00	1.80	60.00	1L5XX
(c)	9 thru 25 miles	19.00	1.80	60.00	1L5XX
(d)	Over 25 miles	19.00	1.80	60.00	1L5XX

3. 9.6 Kbps

Mileage Bands¹

(a)	0 miles	-	-	-	1L5XX
(b)	1 thru 8 miles	19.00	1.80	60.00	1L5XX
(c)	9 thru 25 miles	19.00	1.80	60.00	1L5XX
(d)	Over 25 miles	19.00	1.80	60.00	1L5XX

Note 1: Rate decreases retroactive to December 27, 2004.

Note 2: Effective June 30, 2021, this Service will no longer be available for purchase by new or existing customers. In addition, requests to move, add, change, or renew existing service arrangements will not be accepted. Following the expiration of a customer's existing term agreement, service will be provided on a month-to-month basis at the applicable Monthly rates until the service is discontinued. The Company currently plans to discontinue this service on or after June 30, 2024.

(N)

(N)

BELLSOUTH
 TELECOMMUNICATIONS
 ALABAMA
 ISSUED: May 28, 2021
 BY: President - Alabama
 Birmingham, Alabama

ACCESS SERVICES TARIFF

Ninth Revised Page 67
 Cancels Eighth Revised Page 67

EFFECTIVE: June 30, 2021

E7. SPECIAL ACCESS (A.K.A. BELLSOUTH SPA) SERVICE

E7.5 Rates And Charges (Cont'd)

E7.5.7 Digital Data Access (a.k.a. BellSouth SPA DS0 Digital Data)⁴ Service (Cont'd)

(C)

B. Interoffice Channel (Cont'd)¹

4. 19.2 Kbps

Mileage Bands

		Fixed Monthly Charge	Monthly Charge Per Mile	Nonrecurring Charge	USOC
(a)	0 miles	\$-	\$-	\$-	1L5XX
(b)	1 thru 8 miles	19.00	1.80	60.00	1L5XX
(c)	9 thru 25 miles	19.00	1.80	60.00	1L5XX
(d)	Over 25 miles	19.00	1.80	60.00	1L5XX

5. 56 Kbps

Mileage Bands

(a)	0 miles	-	-	-	1L5XX
(b)	1 thru 8 miles	37.50	3.75	60.00	1L5XX
(c)	9 thru 25 miles	37.50	3.75	60.00	1L5XX
(d)	Over 25 miles	37.50	3.75	60.00	1L5XX

6. 64 Kbps

Mileage Bands

(a)	0 miles	-	-	-	1L5XX
(b)	1 thru 8 miles	37.50	3.75	60.00	1L5XX
(c)	9 thru 25 miles	37.50	3.75	60.00	1L5XX
(d)	Over 25 miles	37.50	3.75	60.00	1L5XX

7. 2.4, 4.8, 9.6 or 19.2 Kbps (Contract Rates)

Mileage Bands

		Nonrecurring Charge Per Channel	Fixed		Per Mile		USOC
			24 to 42 Months^{2,3}	43 to 60 Months^{2,3}	24 to 42 Months^{2,3}	43 to 60 Months^{2,3}	
(a)	0 miles	\$-	\$-	\$-	\$-	\$-	1L5XX
(b)	1 thru 8 miles	60.00	16.00	15.00	1.40	.95	1L5XX
(c)	9 thru 25 miles	60.00	16.00	15.00	1.40	.95	1L5XX
(d)	Over 25 miles	60.00	16.00	15.00	1.40	.95	1L5XX

8. 56.0 and 64.0 Kbps (Contract Rates)

Mileage Bands

(a)	0 miles	\$-	\$-	\$-	\$-	\$-	1L5XX
(b)	1 thru 8 miles	60.00	23.50	20.50	2.75	1.90	1L5XX
(c)	9 thru 25 miles	60.00	23.50	20.50	2.75	1.90	1L5XX
(d)	Over 25 miles	60.00	23.50	20.50	2.75	1.90	1L5XX

Note 1: Rate decreases retroactive to December 27, 2004.

Note 2: Effective November 9th, 2013, customers may not establish new term plans greater than 36 months for Digital Data Access and term plans may not be renewed for a term greater than 36 months.

Note 3: Effective March 24, 2019, Customers may not convert, renew or establish CSPPs for Digital Data Access Service.

Note 4: Effective June 30, 2021, this Service will no longer be available for purchase by new or existing customers. In addition, requests to move, add, change, or renew existing service arrangements will not be accepted. Following the expiration of a customer's existing term agreement, service will be provided on a month-to-month basis at the applicable Monthly rates until the service is discontinued. The Company currently plans to discontinue this service on or after June 30, 2024.

(N)
 |
 (N)

BELLSOUTH
 TELECOMMUNICATIONS
 ALABAMA
 ISSUED: May 28, 2021
 BY: President - Alabama
 Birmingham, Alabama

ACCESS SERVICES TARIFF

Eighth Revised Page 67.1
 Cancels Seventh Revised Page 67.1

EFFECTIVE: June 30, 2021

E7. SPECIAL ACCESS (A.K.A. BELLSOUTH SPA) SERVICE

E7.5 Rates And Charges (Cont'd)

E7.5.7 Digital Data Access (a.k.a. BellSouth SPA DS0 Digital Data)⁷ Service (Cont'd)

(C)

C. Optional Features, Functions and Charges

1. Bridging^{1,2}

		Nonrecurring Charge	Month to Month	24 to 42 Months ^{5,6}	43 to 60 Months ^{5,6}	USOC BCNDA
2.	(a) Per port Digital Data Secondary Channel Capability, per Local Channel Connection ^{1,2,3,4}	\$26.00	\$25.00	\$24.00	\$22.00	
	(a) Each	140.00	16.20	13.00	12.00	SFS

Note 1: This option is not available with 64 Kbps.

Note 2: Not available at all service locations.

Note 3: Nonrecurring charge is applicable only if Secondary Channel service is being added subsequent to the installation of basic service.

Note 4: Rate decreases retroactive to December 27, 2004.

Note 5: Effective November 9th, 2013, customers may not establish new term plans greater than 36 months for Digital Data Access and term plans may not be renewed for a term greater than 36 months.

Note 6: Effective March 24, 2019, Customers may not convert, renew or establish CSPPs for Digital Data Access Service.

Note 7: Effective June 30, 2021, this Service will no longer be available for purchase by new or existing customers. In addition, requests to move, add, change, or renew existing service arrangements will not be accepted. Following the expiration of a customer's existing term agreement, service will be provided on a month-to-month basis at the applicable Monthly rates until the service is discontinued. The Company currently plans to discontinue this service on or after June 30, 2024.

(N)
 |
 (N)

BELLSOUTH
 TELECOMMUNICATIONS
 ALABAMA
 ISSUED: May 28, 2021
 BY: President - Alabama
 Birmingham, Alabama

ACCESS SERVICES TARIFF

Seventh Revised Page 67.2
 Cancels Sixth Revised Page 67.2

EFFECTIVE: June 30, 2021

E7. SPECIAL ACCESS (A.K.A. BELLSOUTH SPA) SERVICE

E7.5 Rates And Charges (Cont'd)

E7.5.7 Digital Data Access (a.k.a. BellSouth SPA DS0 Digital Data)³ Service (Cont'd)

(C)

- C. Optional Features, Functions and Charges (Cont'd)
 - 3.

- 4. Speed Change Charge^{1, 2}

		Nonrecurring Charge		USOC
		First	Additional	SCH
(a)	Per Local Channel	\$330.00	\$165.00	

Note 1: Speed Change Charge is applicable where circuit out of service time during speed change activity is acceptable to customer.

Note 2: Rate decreases retroactive to December 27, 2004.

Note 3: Effective June 30, 2021, this Service will no longer be available for purchase by new or existing customers. In addition, requests to move, add, change, or renew existing service arrangements will not be accepted. Following the expiration of a customer's existing term agreement, service will be provided on a month-to-month basis at the applicable Monthly rates until the service is discontinued. The Company currently plans to discontinue this service on or after June 30, 2024.

(N)
 |
 (N)

BELLSOUTH
 TELECOMMUNICATIONS
 ALABAMA
 ISSUED: May 28, 2021
 BY: President - Alabama
 Birmingham, Alabama

ACCESS SERVICES TARIFF

Ninth Revised Page 70
 Cancels Eighth Revised Page 70

EFFECTIVE: June 30, 2021

E7. SPECIAL ACCESS (A.K.A. BELLSOUTH SPA) SERVICE

E7.5 Rates And Charges (Cont'd)

E7.5.8 High Capacity (a.k.a. BellSouth SPA High Capacity) Service (Cont'd)

C. Optional Features and Functions

1. Channelization

	Monthly Rate	Nonrecurring Charge	USOC
a. DS3 Channelization			
(1) DS3 to DS1			
(a) Per Arrangement ¹	-	-	MXB++
b. DS2 Channelization			
(1) DS2 to DS1			
(a) Per Arrangement ¹	-	-	MXD++
c. DS1C Channelization			
(1) DS1C to DS1			
(a) Per Arrangement ¹	-	-	MXH++
d. DS1 Channelization ³			
(1) DS1 Basic Channelization System (DS1 to VG/ DS0) ²			

	Monthly Rate			Nonrecurring Charge	USOC
	Rate Zone 1	Rate Zone 2	Rate Zone 3		
(a) Per System	\$185.00	\$193.00	\$198.00	\$135.00	MQ1
e. DS0 Channelization ^{3,4}					
(1) DS0 Basic Channelization System (DS0 to Subrate) ² (Per System)					

	Monthly Rate	Nonrecurring Charge	USOC
(a) Maximum of 20, 2.4 Kbps Services	\$120.00	\$135.00	QSU24
(b) Maximum of 10, 4.8 Kbps Services	120.00	135.00	QSU48
(c) Maximum of 5, 9.6 Kbps Services	120.00	135.00	QSU96

Note 1: ICB rates and charges apply.

Note 2: A Central Office Channel Interface is required in addition to a DS1 or DS0 Basic Channelization System for activation of each lesser capacity service.

Note 3: Rate decreases retroactive to December 27, 2004.

Note 4: Effective June 30, 2021, this Service will no longer be available for purchase by new or existing customers. In addition, requests to move, add, change, or renew existing service arrangements will not be accepted. Following the expiration of a customer's existing term agreement, service will be provided on a month-to-month basis at the applicable Monthly rates until the service is discontinued. The Company currently plans to discontinue this service on or after June 30, 2024.

(C)

(N)
 |
 (N)

BELLSOUTH
 TELECOMMUNICATIONS
 ALABAMA
 ISSUED: May 28, 2021
 BY: President - Alabama
 Birmingham, Alabama

ACCESS SERVICES TARIFF

Ninth Revised Page 70.1
 Cancels Eighth Revised Page 70.1

EFFECTIVE: June 30, 2021

E7. SPECIAL ACCESS (A.K.A. BELLSOUTH SPA) SERVICE

E7.5 Rates And Charges (Cont'd)

E7.5.8 High Capacity (a.k.a. BellSouth SPA High Capacity) Service (Cont'd)

C. Optional Features and Functions (Cont'd)

2. Channel Interfaces (Per Interface)¹

a. Sub-DS3 Interfaces

(1) DS1 Level Central Office Channel Interface

	Nonrecurring Charge	Month to Month	24 to 48 Months ²	49 to 72 Months ^{2,3}	73 to 96 Months ^{2,3}	USOC
(a) Asynchronous	\$160.00	\$12.00	\$8.00	\$7.00	\$6.00	1D3CA
(b) Synchronous	135.00	36.00	31.00	28.00	25.00	1D3CS
(2) DS1 Level Customer Channel Interface						
(a) Asynchronous	280.00	17.00	13.00	13.00	13.00	1D3DA
(b) Synchronous	245.00	45.00	36.00	33.00	30.00	1D3DS

b. Sub-DS1 Level Interfaces⁴

(1) VG/DS0 Level Central Office Channel Interface

	Nonrecurring First Charge	Additional Charge	Month to Month	USOC
(a) Switched Access	\$0.00	\$0.00	\$0.00	1D1SW
(b) Voice Grade	7.00	5.00	6.30	1D1VG
(c) WATS Access Line	7.00	5.00	6.30	1D1WT
(d) DDAS	7.00	7.00	12.55	1D1DD

c. Sub-DS0 Level Interfaces⁴

(1) Subrate Central Office Channel Interface

(a) Subrate (2.4, 4.8, & 9.6 Kbps)	7.00	5.00	12.55	1DOSR
------------------------------------	------	------	-------	-------

Note 1: Rate decreases retroactive to December 27, 2004.

Note 2: Effective November 9th, 2013, customers may not establish new term plans greater than 36 months for High Capacity Service and term plans may not be renewed or extended for a term greater than 36 months.

Note 3: Effective March 24, 2019, Customers may not: (1) Establish CSPPs greater than 36 months for High Capacity Service, and (2) Convert or renew CSPPs for High Capacity Service.

Note 4: Effective June 30, 2021, this Service will no longer be available for purchase by new or existing customers. In addition, requests to move, add, change, or renew existing service arrangements will not be accepted. Following the expiration of a customer's existing term agreement, service will be provided on a month-to-month basis at the applicable Monthly rates until the service is discontinued. The Company currently plans to discontinue this service on or after June 30, 2024.

(N)
 |
 (N)

