

29. Dedicated SONET Ring Service

29.1 General Description

(A) Basic Service Description

Dedicated SONET Ring OC-3, OC-12 and OC-48 Service provides customers with a dedicated custom network. The network is in a ring architecture, including sub-rings or Arc sub-rings provisioned on Next Generation SONET equipment, designed to provide increased reliability and functionality connecting multiple customer designated locations and specified Telephone Company Central Offices (COs) via self-healing network designs. Dedicated SONET Rings OC-3, OC-12 and OC-48 are available via Self-Healing Uni-Directional Path Switched Rings (UPSR); additionally, OC-48 is available via Self-Healing Bi-Directional Line Switched Rings (BLSR). The dedicated ring can connect multiple (between 2 and 16) customer-designated locations and telephone company central offices, where SONET facilities and equipment are available. The Dedicated SONET Ring services will interface with other compatible Telephone Company provided Special Access Services (i.e. DS1, DS3), as provided by this Guidebook and Tariff F.C.C. No. 73.

Rates and charges for Dedicated SONET Ring Service are set forth in Section 29.4, with the exception of the services provided by the Telephone Company in the Metropolitan Statistical Areas (MSAs) in which the Telephone Company has received Phase II pricing flexibility pursuant to Subpart H of Part 69 of the Commission's Rules. The rates and charges for the Dedicated SONET Ring Service in the MSAs that have received Phase II pricing flexibility are set forth in Section 39. (D)

Rate elements include nodes, ports, mileage between nodes and regenerators. Rates are specified in Section 29.4. (D)

(B) Service Provisioning

(1) Manner of Provisioning

All customers will be served from the nearest suitably equipped end office. Information pertaining to end offices equipped to provide Dedicated Ring Service is set forth in National Exchange Carrier Association, Inc. Tariff F.C.C. No. 4. Dedicated SONET Ring Service will be provided subject to the availability and limitations of The Telephone Company's wire centers and outside plant facilities. Dedicated SONET Ring Service is only available where technical capabilities permit such facility distance and type of physical plant. Where facilities are not available, Special Construction charges may apply. (D)

(2) Limitations

The Telephone Company does not undertake to originate data, but offers the use of its Dedicated SONET Ring Service, where available, to customers for the purpose of transporting data originated by the customer or a third party.

(3) Allowance for Service Interruptions

Dedicated SONET Ring Service provides Automatic Protection Switching to assure 100 percent availability of the services on the ring. A service interruption will result in a credit equal to one month's bill for the individual port-to-port connection involved. An interruption of service will start when an inoperative service is reported to the Telephone Company and end when the service is operative. In any month, as a result of an interruption, the total credit per rate element of the interrupted service may not exceed 100 percent of the monthly charge for that particular rate element.

In the event that protected facilities do not exist (including dual entrance facilities) and the customer does not utilize Special Construction to provide protected facilities, the unprotected dedicated ring will be provided. In addition, the customer waives the right to receive the SAWS credit allowance, as described in Part 2, Section 2 of this Guidebook.

(T)

(C) Responsibility of The Telephone Company

The Telephone Company will provision and maintain Dedicated SONET Ring Service for the customer up to and including the Network Interface (NI).

(D) Rights of The Telephone Company

The Telephone Company will not provision Dedicated SONET Ring Service if it has reasonably determined that (a) it is not technically feasible over existing facilities or (b) it will cause interference problems within The Telephone Company's network or other facilities.

During The Telephone Company's network maintenance and software update period, it may be necessary to temporarily place the Dedicated SONET Ring Service central office equipment out of service. The Telephone Company also reserves the right to temporarily interrupt Dedicated SONET Ring Service at other times in emergency situations.

ACCESS SERVICE

(E) Responsibility of Customer

The customer is responsible for providing compatible customer provided equipment (CPE) that is used for connection to Dedicated SONET Ring Service.

29.2 Technical Specifications

Technical specifications for Dedicated SONET Ring Service are listed in the following Telephone Company publications:

- (1) TP 76839 SONET Transmission Requirements Performance and Interface Specifications
- (2) AM TR-NIS-000111 Ameritech OC-3, OC-12, OC-48 and OC-192 Service Interface Specifications
- (3) AM TR-TMO-000101 Ameritech Digital Service Transmission Parameters for Performance
- (4) SBC-TP-76412-000 Customer Interface Standards for 100 Mbps and Higher Excluding SONET Interfaces

Dedicated SONET Ring Service offers the following SONET (Synchronous Optical Network) based Interfaces:

DS1 1.544 Mbps
DS3 44.736 Mbps
EC-1 51.84 Mbps
OC-3 155.520 Mbps
OC-3c 155.520 Mbps (concatenated)
OC-12 622.080 Mbps
OC-12c 622.080 Mbps (concatenated)
OC-48 2488.32 Mbps
Ethernet 100 Mbps
Ethernet 1Gbps

29.3 Rate Conditions(A) Rate Elements(1) Nodes

The ring will provide connectivity to multiple customer designated locations (nodes). However, a ring must have a minimum of two nodes, excluding sub-ring nodes. At least one node must be a Telephone Company Central Office (CO) node. A maximum of 16 nodes including regenerators will be allowed per ring.

The Telephone Company reserves the right to determine the order of the nodes on the ring.

When a customer premises node is located in the same building as a CO node, diversity between the two nodes may not be available.

If a customer collocates two customer premises nodes of the same speed, on the same dedicated ring, on the same premises, the additional node will be billed as shown in Section 29.4. This option does not provide diversity between these two collocated nodes and the rest of the ring.

If a customer has one or more additional OC-48 Dedicated SONET Rings within a LATA, the Customer Premises Node, Central Office Node and the OC-48 Add/Drop Capability rate elements utilized on the additional OC-48 Dedicated SONET Ring(s) and co-located with like primary OC-48 Dedicated Ring rate elements as described below will be billed as "Plus"⁽¹⁾ as shown in Section 29.4. All existing requirements associated with Dedicated SONET Ring Service apply to additional rings. The eligibility requirements for the "Plus"⁽¹⁾ rates are as follows:

(T)

The primary dedicated ring is defined as the dedicated SONET ring with the earliest installation date. If the primary dedicated SONET ring is terminated by the customer and the customer still has two or more dedicated SONET rings, the remaining dedicated SONET ring with the earliest installation date will be designated as the new primary dedicated SONET ring. If there are any additional dedicated rings, the nodes and add/drop capability that are common with the new primary dedicated SONET ring will be billed as "Plus"⁽¹⁾ nodes and "Plus"⁽¹⁾ add/drop capability.

If the primary OC-48 Dedicated SONET Ring has either two or three nodes, then at least two nodes (excluding sub-ring or Arc sub-ring nodes) with separate addresses must be common between the primary OC-48 Dedicated SONET Ring and the additional OC-48 Dedicated SONET Ring(s). At least one of the common nodes must be a customer premise node and at least one of the nodes must be a central office node.

(1) Effective 03/18/06, the OC-48 "Plus" feature will no longer be available to new customers. There will be no change to existing customers.

If the primary OC-48 Dedicated SONET Ring has four or more nodes, then at least three nodes (excluding sub-ring or Arc sub-ring nodes) with separate addresses must be common between the primary OC-48 Dedicated SONET Ring and the additional OC-48 Dedicated SONET Ring(s). At least one of the common nodes must be a central office node.

The customer will be billed time and material, as set forth in Section 13, for any additional charges incurred by the Telephone Company in locating Telephone Company equipment at the customer premises. (T) (T)

(a) Direct Drop Node⁽¹⁾

An optional Direct Drop Node (DDN) is available on an OC-12 Dedicated ring. This node has direct add/drop capability not to exceed 3 DS3s or its equivalent.

The remaining bandwidth of the OC-12 ring continues on through the Node to another drop point on the ring. Use of the Direct Drop Node allows customers to drop DS1s directly from the Node without the need for the Optical to Electrical DS1 Add/Drop Capability option.

OC-12 nodes and OC-12 DDNs may be used together in making up an OC-12 dedicated ring. A DS1 that enters the ring via a port on a Direct Drop Node must also exit via a port on another Direct Drop Node (DDN on - DDN off). A DS3 that enters the ring via a port on a Direct Drop Node may exit via a port on either a Direct Drop Node or OC-12 node. Direct Drop Node is not available in a two-node ring configuration.

(b) Sub-Ring Node

A sub-ring node is a lower speed optical extension off a main ring. It traverses one or more main ring nodes via the use of OC-N port connections on and off the main ring. The primary use of sub-ring nodes is to provide the ability to fully utilize the bandwidth around the ring when the customer requires DS1/VT1.5 circuit paths.

(1) Effective 03/18/06, the Direct Drop Node feature will no longer be available to new customers. There will be no change to existing customers.

An optional sub-ring node is available at OC-3 and OC-12 speeds from an OC-48 main ring and OC-3 speed from an OC-12 main ring. A sub-ring node may only connect to the main ring at the same or an adjacent main ring node. A sub-ring node may not connect directly to another sub-ring node.⁽¹⁾

Any service that enters the main ring via a port on a sub-ring node must also exit via a port on another sub-ring node (sub-ring on - sub-ring off).⁽¹⁾ Cascading sub-rings are not allowed off a main ring. Service circuits may not be established between sub-ring nodes connecting to the same main ring node or between a sub-ring node and a port on the same main ring node to which it connects.

Each sub-ring must be implemented as an OC-M on an OC-N ring with full complement of STS-1s, STS-3s or STS-12s depending on the bandwidth of the sub-ring, appearing together at all associated sub-ring nodes on a given sub-ring.

OC-3 sub-rings and OC-12 DDNs may not be combined on an OC-12 main ring. OC-12 sub-rings and OC-12 DDNs may be combined on a sub-ring connected to an OC-48 main ring.

Two OC-N ports and associated node charges apply for each sub-ring node connected to the main ring, as well as applicable mileage for the sub-ring applies.

A sub-ring node which is co-located with a main ring node at the customers premises (for the same dedicated ring) will be billed as an "Additional Node" as set forth in Section 29.4(A). A sub-ring is not available with a two-node main ring configuration. (T)

(c) Arc Sub-Ring Node

Arc sub-ring nodes are only available on Next Generation SONET equipment with service installed after November 2, 2007. An Arc sub-ring node is a lower speed optical extension off a main ring. It connects to one main ring node via the use of OC-N port connections from and to a main ring. The primary use of Arc sub-ring nodes is to add other locations to the ring that will utilize minimal amounts of bandwidth from the main ring. (T)

⁽¹⁾ This restriction does not apply for Next Generation SONET equipment.

Arc sub-rings are only available off of UPSR main rings. Arc sub-rings are only available where facilities and/or operating conditions permit, as determined by the Telephone Company.

An optical Arc sub-ring node is available at OC-3, OC-12 and OC-48 speeds from an OC-192 main ring, OC-3 and OC-12 speeds from an OC-48 main ring, and OC-3 speed from an OC-12 main ring. An Arc sub-ring node may connect to the main ring at any main ring node.

Cascading Arc sub-rings are not allowed off a main ring. Services entering an Arc sub-ring node cannot drop from the directly connecting main ring node (hairpinning).

More than one Arc sub-ring may be added to a main ring. Each Arc sub-ring must be implemented as an OC-M on an OC-N ring with a full compliment of STS-1s, 3s or 12s, depending on the bandwidth of the Arc sub-ring, appearing together at all associated Arc sub-ring nodes on a given Arc sub-ring.

Two OC-N ports apply for each Arc sub-ring node connected to the main ring. A node charge applies for each Arc sub-ring location. Mileage charges are applicable when the sub-ring is in a different location than the main ring.

An Arc sub-ring node which is collocated in the same room with a main ring node at the customer's premises (for the same dedicated ring) will be billed as an "Additional Node."

Arc sub-rings do not reduce the bandwidth capacity of the main ring. As services are added to the main or sub-ring, only the bandwidth capacity of the service is reduced.

Arc sub-rings can be provisioned in two basic configurations:

1. Single-node, single-homed ARC
2. Multi-node, single-homed ARC

Circuit traffic can be added/dropped from an Arc sub-ring node to another Arc sub-ring node within the same Arc (known as intra-ARC), or between ARCs (known as inter-ARC). Intra-ARC circuits can only be provisioned as unprotected due to technical limitations. Circuit traffic can also originate on an Arc sub-ring node and route across and drop from a main ring node, but only when UPSR protection schemes are used.

(d) Re-Map Node ⁽¹⁾

(N)

A Re-Map node is a ring node that is pre-equipped and dedicated to customer traffic that is re-mapped/re-routed to it by the Telephone Company (upon notification by the customer of a service outage at another customer premises node on the same dedicated ring).

Re-Map is designed as a temporary service for disaster recovery purposes only. No "normal" customer traffic will be added/dropped at the Re-Map node unless the Re-Map service is activated.

(e) Flex-Ring

Flex-Ring feature provides double the standard bandwidth levels for the Dedicated Ring product. The customer has the ability to double their bandwidth without ordering the next higher ring service.

(1) Double-Rings

Double-Rings will provide the ability to place two rings on the same DSRS equipment. Nodes of the second ring must be the same as the first ring. The second OC-12 and OC-48 ring is available and will require a new TPP upon the upgrade. All nodes on the ring will be at the same level. The additional higher speed optics may contribute to slot exhaustion on the main node. The standard features and components (mileage, ports, etc.) are available as described in Section 29.3(A). The second ring will require another pair of fibers so mileage will apply to both rings. There will only be two rings available on a single SONET ring equipment. The second ring's line rate will be the same as the first ring.

⁽¹⁾ Effective August 1, 2013, availability of Re-Map nodes is limited to Re-Map nodes that are in service or have been ordered prior to August 1, 2013. (N)
(N)

(2) OC-48 Add/Drop Capability

This provides the capability to add/drop lower speed channels from an OC-48 Dedicated Ring node location via OC-12 and OC-3 ports. OC-48 Add/Drop Capability at an OC-48 Dedicated SONET Ring Service node location will support any combination of service traffic not to exceed 48 STS-1 equivalents.

OC-48 Add/Drop Capability associated with OC-48 Dedicated SONET Ring nodes that qualify as "Plus"⁽¹⁾ nodes, as defined in Section 29.3(A)(1), will be billed as "Plus"⁽¹⁾ as shown in Section 29.4. (T)
(T)

For OC-48 SONET Rings established prior to 03/24/05, the Add/Drop capability charge is applied per node. Customers may upgrade their existing ring provided that new TPP is equal to or greater than their existing TPP and the new MRC revenue is equal to or greater than their existing MRC revenue.

For OC-48 SONET Rings established after 03/24/05, the Add/Drop capability charge is applied only once and only when the 25th DS-3 port is applied per node.

(3) Ports

Lower speed channels are accessible at nodes via port terminations. Ports provide access to lower-speed services at each node (e.g. DS1, DS3, STS-1, EC-1, OC-3, OC-12, 100 Mbps Ethernet, 1 Gbps Ethernet and possibly OC-12 or OC-48, depending on the bandwidth of the ring). Port configuration requirements are provided by the customer when the Dedicated SONET Ring service is ordered. The capacity of the selected OC-3, OC-12 or OC-48 Dedicated SONET Ring service is determined by the number of individual port-to-port connections available between all nodes on the ring.

(1) Effective 03/18/06, the OC-48 "Plus" feature will no longer be available to new customers. There will be no change to existing customers.

Accepted interfaces are as follows:

	OC-3 Node	OC-12 Node	OC-48 Node
DS1 Ports	X (Max. 84/Node)	X ⁽¹⁾ (Max. 84/OC-3 or OC-3c Port)	X ⁽¹⁾ (Max. 84/OC-3, OC-3c Port)
DS3 Ports	X (Max. 3/Node)	X (Max. 12/Node)	X (Max. 48/Node)
EC-1 Ports	X (Max. 3/Node)	X (Max. 12/Node)	X (Max. 48/Node)
OC-3/3c Ports ⁽²⁾	X (Max. 1/Node)	X (Max. 4/Node)	X (Max. 16/Node)
OC-12/12c Ports ⁽²⁾	N/A	X (Max. 1/Node)	X (Max. 4/Node)
OC-48/48c Ports ⁽²⁾	N/A	N/A	X (Max. 1/Node)
100 Mbps (STS-1) Ethernet Port	X (Max. 3/Node)	X (Max. 12/Node)	X (Max. 48/Node)
100 Mbps (STS-3c) Ethernet Port	N/A	X (Max. 4/Node)	X (Max. 16/Node)
1 Gbps (STS-1) Ethernet Port	X (Max. 3/Node)	X (Max. 12/Node)	X (Max. 48/Node)
1 Gbps (STS-3c) Ethernet Port	N/A	X (Max. 4/Node)	X (Max. 16/Node)
1 Gbps (STS-12c) Ethernet Port	N/A	N/A	X (Max. 4/Node)
1 Gbps (STS-24c) Ethernet Port	N/A	N/A	X (Max. 2/Node)
10/100 BaseT Ethernet Port			
VT1.5-1v (1.6 Mbps)	X (Max. 84/Node)	X (Max. 84/OC-3)	X (Max. 84/OC-3)
VT1.5-2v (3.2 Mbps)	X (Max. 42/Node)	X (Max. 42/OC-3)	X (Max. 42/OC-3)
VT1.5-3v (4.8 Mbps)	X (Max. 28/Node)	X (Max. 28/OC-3)	X (Max. 28/OC-3)
VT1.5-4v (6.4 Mbps)	X (Max. 21/Node)	X (Max. 21/OC-3)	X (Max. 21/OC-3)
VT1.5-5v (8.0 Mbps)	X (Max. 16/Node)	X (Max. 16/OC-3)	X (Max. 16/OC-3)
VT1.5-6v (9.6 Mbps)	X (Max. 14/Node)	X (Max. 14/OC-3)	X (Max. 14/OC-3)
VT1.5-7v (11.2 Mbps)	X (Max. 12/Node)	X (Max. 12/OC-3)	X (Max. 12/OC-3)
VT1.5-8v (12.40 Mbps)	X (Max. 10/Node)	X (Max. 10/OC-3)	X (Max. 10/OC-3)
VT1.5-10v (16.0 Mbps)	X (Max. 8/Node)	X (Max. 8/OC-3)	X (Max. 8/OC-3)
VT1.5-13v (20.8 Mbps)	X (Max. 6/Node)	X (Max. 6/OC-3)	X (Max. 6/OC-3)
STS-1-1v (48.38 Mbps)	X (Max. 3/Node)	X (Max. 12/Node)	X (Max. 48/Node)
STS-1-2v (96.77 Mbps)	X (Max. 1/Node)	X (Max. 6/Node)	X (Max. 24/Node)
1000 BaseSX/LX Ethernet Port			
STS-1-1v (48.38 Mbps)	X (Max. 3/Node)	X (Max. 12/Node)	X (Max. 48/Node)
STS-1-2v (96.77 Mbps)	X (Max. 1/Node)	X (Max. 6/Node)	X (Max. 24/Node)
STS-1-3v (145.15 Mbps)	X (Max. 1/Node)	X (Max. 4/Node)	X (Max. 16/Node)
STS-1-4v (193.54 Mbps)	N/A	X (Max. 3/Node)	X (Max. 12/Node)
STS-1-5v (241.92 Mbps)	N/A	X (Max. 2/Node)	X (Max. 9/Node)
STS-1-6v (290.30 Mbps)	N/A	X (Max. 2/Node)	X (Max. 8/Node)
STS 1-9v (435.46 Mbps)	N/A	X (Max. 1/Node)	X (Max. 5/Node)
STS-1-12v (580.61 Mbps)	N/A	X (Max. 1/Node)	X (Max. 4/Node)
STS-1-21v (1016.06 Mbps)	N/A	N/A	X (Max. 2/Node)
STS-3c-1v (149.76 Mbps)	N/A	X (Max. 4/Node)	X (Max. 16/Node)
STS-3c-2v (299.52 Mbps)	N/A	X (Max. 2/Node)	X (Max. 8/Node)
STS-3c-3v (449.28 Mbps)	N/A	X (Max. 1/Node)	X (Max. 5/Node)
STS-3c-4v (599.04 Mbps)	N/A	X (Max. 1/Node)	X (Max. 4/Node)
STS-3c-7v (1048.32 Mbps)	N/A	N/A	X (Max. 2/Node)

- (1) Optical to Electrical DS1 Add/Drop Capability, as described in Section 29.3(A) (5), is needed along with an OC-3 port unless the customer has chosen an OC-12 DDN. (T)
- (2) OC-3 and OC-3c ports support both OC-3 and OC-3c bandwidths. OC-12 and OC-12c ports support both OC-12 and OC-12c bandwidths. OC-48 and OC-48c ports support both OC-48 and OC-48c bandwidths. (T)

By using the existing OC-3 or OC-12 Service and cross-connection capability, OC-3 point-to-point service may connect to an OC-3 port of an OC-12 or OC-48 ring or OC-12 point-to-point service may connect to an OC-12 port of an OC-48 ring located in a Telephone Company CO.

An OC-3 port will permit the connection of STS-1 channels to other STS-1 channels across the OC-12 or OC-48 Dedicated SONET Ring Service subject to the overall ring capacity limits described in Section 29.3(A) (7). Also, an STS-1 channel with DS1 (T) payload mapping accessing an OC-12 Dedicated SONET Ring using an OC-3 port may be connected to the Optical-to-Electrical DS1 Add/Drop Capability for the purpose of connecting up to 28 DS1 ports. An STS-1 channel with DS3 payload mapping accessing the OC-12 or OC-48 Dedicated SONET Ring using an OC-3 port may individually connect to a DS3 or EC-1 port.

When a customer orders a Re-Map node,⁽¹⁾ a minimum number of Re-Map ports must be equipped;

OC-3 28 DS1 Re-Map ports, or 1 DS3 Re-Map port
 OC-12 28 DS1 Re-Map ports, or 3 DS3 Re-Map ports, or 1 OC-3
 or OC-3c Re-Map port
 OC-48 28 DS1 Re-Map ports, or 3 DS3 Re-Map ports, or 1 OC-3
 or OC-3c Re-Map port or 1 OC-12 Re-Map port

Re-Map node ports must be ordered in incremental blocks as described below:

	Port Type			
	DS1	DS3	OC-3 or OC-3c	OC-12 or OC-12c
OC-3 Ring	28, 56 or 84 (multiples of 28)	1, 2, or 3	N/A	N/A
OC-12 Ring	28, 56, 84 (multiples of 28)	3, 6, 9, or 12	1, 2, 3, or 4	N/A
OC-48 Ring	28, 56, 84 (multiples of 28)	3, 6, 9... or 48	1, 2, 3... or 16	1, 2, 3 or 4

An OC-12 or OC-48 ring utilizing re-map requires an OC-3 or OC-3c or OC-3c Re-Map port and DS1 Re-Map Add/Drop Capability to support DS1 port types. (An OC-3 or OC-3c Re-Map port and DS1 Re-Map Add/Drop Capability supports up to 84 DS1's.)

⁽¹⁾ Effective August 1, 2013, availability of Re-Map nodes is limited to Re-Map nodes that are in service or have been ordered prior to August 1, 2013.

Transmux

DS3 Transmux is available on all speeds and provides the ability to aggregate multiple DS1s to a DS3 within the SONET Ring and also on a single card. DS1s are aggregated across the SONET network and terminated into a single DS3 card at a ring node. The hand-off will be a channelized DS3. Aggregation of DS1s can occur across multiple DS3/STs.

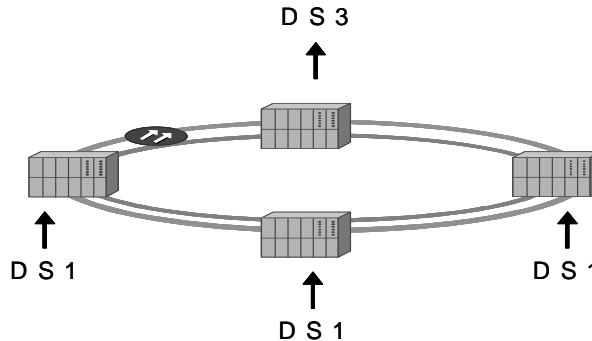
(4) Mileage

Mileage is the total airline distance between the serving wire center of each node involved on the ring. A one-mile minimum will be billed between nodes. A two-node ring configuration has a two-mile minimum - one mile from the wire center node to the customer premises node, and one mile from the customer premises node to the wire center node.

(5) Optical to Electrical DS1 Add/Drop Capability⁽¹⁾

This option allows an electrical DS1 to be derived from an optical OC-12 or OC-48 ring by using this capability to add/drop the electrical DS1 from an OC-3 port.

For SONET Rings established after 03/24/05, the Optical-to-Electrical DS-1 Add/Drop capability charge is applied when the 85th DS-1 port is required per OC-12 node. Additional charges will apply per each subsequent increment of 84 DS-1 ports.

For SONET Rings established after 08/02/07, the Optical-to-Electrical DS-1 Add/Drop Capability charge is required when the 29th DS-1 port is ordered per OC-48 node.

(6) Dedicated SONET Ring Regenerator

Regenerators provide essential detection and retransmission of SONET Optical 155.52 Mbps, 622.08 Mbps and 2488.32 Mbps signals between nodes. Regenerators will only be provided as required by the Telephone Company when actual fiber facility distances between nodes exceed inter-nodal design limits (typically 20 to 25 miles). Regenerators will be located exclusively in Telephone Company COs and do not allow ports to access customer service connections.

(1) Optical-to-Electrical DS1 Add/Drop Capability as described in 29.3(A) (5) is needed along with an OC-3 port unless the customer has chosen an OC-12 DDN.

(7) Dedicated SONET Ring Connection Capacity

Maximum transport capacity of OC-3, OC-12 and OC-48 Dedicated SONET Ring Service is characterized by the total quantity of individual port-to-port connections allowed between all nodes on the ring. The DS3 Port connections shown below in this section can be exchanged with EC-1 Port connections.

For OC-3 Dedicated SONET Ring Service, the maximum ring capacity will be equal to one of the following combinations:

DS3 Port to DS3 Port Connections		DS1 Port to DS1 Port Connections
Three	and	None
Two	and	Up to 28
One	and	Up to 56
None	and	Up to 84

An OC-3 sub-ring or Arc sub-ring provided as part of OC-12 or OC-48 Dedicated SONET Ring Service has a maximum capacity equal to one of the above combinations.

For OC-3 Dedicated SONET Ring Service and OC-3 sub-rings or Arc sub-rings, as part of OC-12 or OC-48 Dedicated SONET Ring Service, individual DS1 port-to-DS1 port and DS3 port-to-DS3 port connections capacities may be incrementally distributed between nodes on the ring in any manner.

For OC-12 Dedicated SONET Ring Service, the maximum ring capacity will be equal to one of the following combinations:

DS3 Port to DS3 Port Connections	and	DS1 Port to DS1 Port Connections
Twelve	and	None
Eleven	and	One Group of 28
Ten	and	Two Groups of 28 (56)
Nine	and	Three Groups of 28 (84)
Eight	and	Four Groups of 28 (112)
Seven	and	Five Groups of 28 (140)

Six	and	Six Groups of 28 (168)
Five	and	Seven Groups of 28 (196)
Four	and	Eight Groups of 28 (224)
Three	and	Nine Groups of 28 (252)
Two	and	Ten Groups of 28 (280)
One	and	Eleven Groups of 28 (308)
None	and	Twelve Groups of 28 (336)

An OC-12 sub-ring or Arc sub-ring provided as part of OC-48 Dedicated SONET Ring Service has a maximum capacity equal to one of the above combinations.

For OC-12 Dedicated SONET Ring Service and OC-12 sub-rings or Arc sub-rings, as part of OC-48 Dedicated SONET Ring Service, individual DS1 port-to-DS1 port connection and DS3 port-to-DS3 port connection may be incrementally distributed between nodes on the ring in any manner.

For OC-12 Dedicated SONET Ring Service using OC-12 Direct Drop⁽¹⁾ Nodes, the maximum ring capacity will be up to 84 DS1 port-to-port connections, together with up to 9 DS3 port-to-port connections (not to be added/dropped at the DDN), or equivalent. Individual DS1 port-to-port connections up to a total of 84 may be incrementally distributed between OC-12 Direct Drop Nodes on the ring in any manner.

(1) Effective 03/18/06, the Direct Drop Node feature will no longer be available to new customers. There will be no change to existing customers.

OC-12 Dedicated SONET Ring Service will also provide capability for node-to-node connection of STS-1 or STS-3C channels using OC-3 or OC-3c ports on the OC-12 ring. Each STS-1 to STS-1 channel connection or STS-1 channel to DS3 port connection requested by the customer will reduce the remaining ring capacity by the equivalent of one DS3 port-to-DS3 port connection or 28 DS1 port-to-DS1 port connections. Each STS-3C to STS-3C channel connection requested by the customer will reduce the remaining ring capacity by the equivalent of three DS3 port-to-DS3 port connections or 84 DS1 port-to-DS1 port connections.

An OC-3 Sub-ring provided as part of an OC-12 Dedicated SONET Ring Service reduces the remaining OC-12 ring capacity by the equivalent of three DS3 port-to-DS3 port connections or 84 DS1 port-to-DS1 port connections.

For OC-48 Dedicated SONET Ring Service, the maximum ring capacity will be equal to one of the following combinations:

<i>DS3 Port-to-DS3 Port Connections</i>		<i>DS1 Port-to-DS1 Port Connections</i>	<i>DS3 Port-to-DS3 Port Connections</i>		<i>DS1 Port-to-DS1 Port Connections</i>
Forty-eight	and	None	Forty-one	and	Seven Groups of 28 (196)
Forty-seven	and	One Group of 28	Forty	and	Eight Groups of 28 (224)
Forty-six	and	Two Groups of 28 (56)	Thirty-nine	and	Nine Groups of 28 (252)
Forty-five	and	Three Groups of 28 (84)	Thirty-eight	and	Ten Groups of 28 (280)
Forty-four	and	Four Groups of 28 (112)	Thirty-seven	and	Eleven Groups of 28 (308)
Forty-three	and	Five Groups of 28 (140)	Thirty-six	and	Twelve Groups of 28 (336)
Forty-two	and	Six Groups of 28 (168)	Continuing down the scale to: None and Forty-eight Groups of 28 (1344)		

For OC-48 Dedicated SONET Ring Service, individual DS1 port-to-DS1 port connection capacities may be distributed only in incremental groups of 28 between any two nodes on the ring. Individual DS3 port-to-DS3 port connection capacities may be incrementally distributed between nodes on the ring in any manner.

OC-48 Dedicated SONET Ring Service also provides capability for node-to-node connection of STS-1 or STS-3c channels using OC-3, OC-3c, OC-12, OC-12c, 100 Mbps Ethernet or 1 Gbps Ethernet ports on the OC-48 ring. Each STS-1 to STS-1 channel connection or STS-1 channel to DS3 port connection requested by the customer reduces the remaining ring capacity by the equivalent of one DS3 port-to-port connection or 28 DS1 port-to-port connections. Each STS-3c to STS-3c channel connection requested by the customer reduces the remaining ring capacity by the equivalent of three DS3 port-to-DS3 port connections or 84 DS1 port-to-DS1 port connections.

An OC-3 Sub-ring provided as part of OC-48 Dedicated SONET Ring Service reduces the remaining OC-48 ring capacity by the equivalent of three DS3 port-to-DS3 port connections or 84 DS1 port-to-DS1 port connections.

OC-48 Dedicated SONET Ring Service also provides capability for node-to-node connections of STS-12c channels using OC-12 ports on the OC-48 ring. Each STS-12c to STS-12c channel connection requested by the customer reduces the remaining ring capacity by the equivalent of twelve DS3 port-to-DS3 port connections or 336 DS1 port-to-DS1 port connections.

An OC-12 Sub-ring provided as part of OC-48 Dedicated SONET Ring Service reduces the remaining OC-48 ring capacity by the equivalent of twelve DS3 port-to-DS3 port connections or 336 DS1 port-to-DS1 port connections.

Ethernet over SONET (EoS) allows the efficient transport of Ethernet frames using SONET. Ethernet ports will be available in bandwidths up to the Ethernet interface of 100 Mbps or 1 Gbps on Dedicated SONET Ring Services. As SONET bandwidths will be preset, the customer will be unable to transmit data (including any bursts) beyond these preset SONET bandwidths. Interfaces of 100 Mbps Ethernet or 1 Gbps Ethernet are available only to customers with Next Generation SONET equipment. Only Single-Mode Fiber is available in the Central Office. The EoS line rates, defined in Section 29.4 (C), are based on the theoretical SONET payload line rates as per GR-253-CORE, Issue 4. These values are not representative of the true Ethernet transport capacity of the EoS circuit. (T)

Additional features are provided with the Ethernet over SONET (EoS) capability.

Virtual Concatenation (VCAT) provides the ability and flexibility to size the customer's bandwidth, sub-rate VT1.5 and super-rate STS-1 and 3c service payloads, based on their traffic requirements. For transport of payloads that do not fit efficiently into the standard set of VT1.5, STS-1 and SRS-Nc payload envelopes, virtual concatenation can be used.

(8) Electrical Connection - Level 1 (EC-1)

EC-1 is an electrical interface that can transport up to 51.84 Mb of bandwidth in a concatenated format. The EC1 port is available on an OC-3, OC-12 and OC-48 ring. For the above connection capacity charts, the quantity of EC-1 ports is equivalent to the connection capacity of a DS-3.

(A) Diagrams

(1) Sub-Ring Node

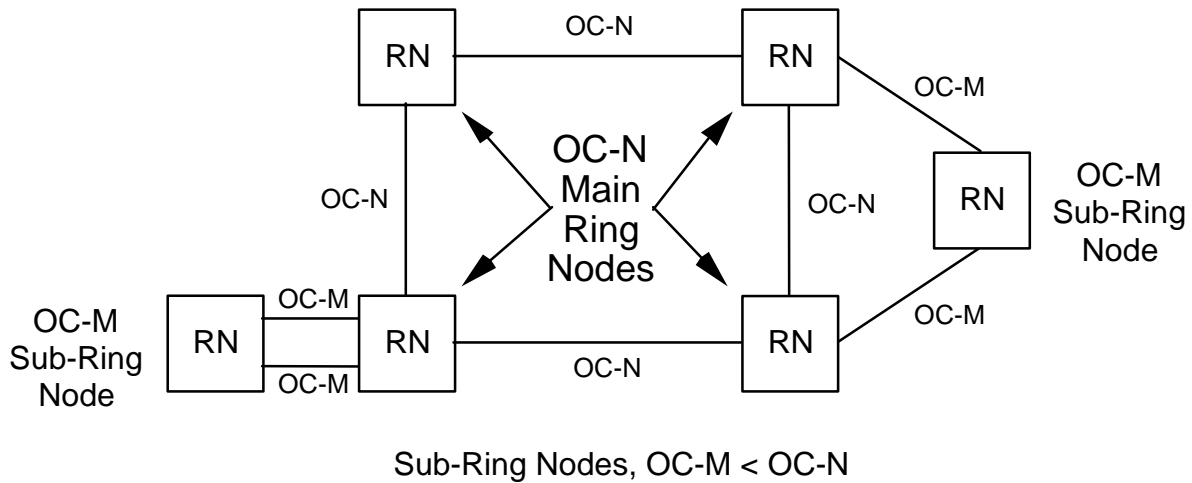

(2) Arc Sub-Ring Node

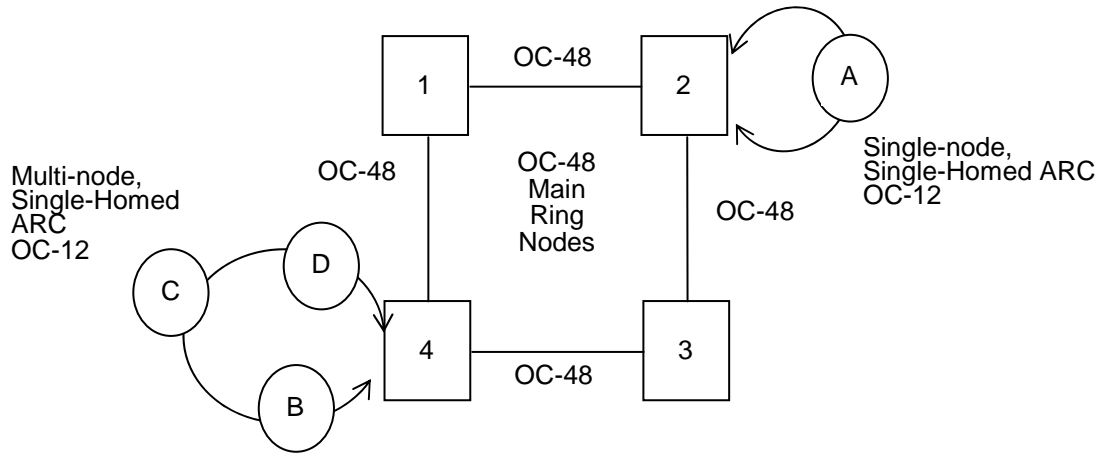

ARC Sub-Ring Nodes, OC-M < OC-N

OC-48 Dedicated Ring shown as example.

(C) Term Pricing Plan⁽¹⁾(1) General Description

Dedicated SONET Rings are available for either 36- or 60-month Term Pricing Plan (TPP) periods⁽²⁾. Monthly recurring charges (C) apply for the nodes, ports, mileage between nodes, and regenerators.

(2) Nonrecurring Charges

Nonrecurring Charges, as set forth in Section 29.4, will apply for those arrangements ordered under the Dedicated SONET Ring TPP. The Access Order Charge, as described in Part 2, Section 5 of this Guidebook, does not apply.

(3) Rate Flow Through

Any decreases in recurring rates will be passed on to customers who participate in the TPP. The Telephone Company will notify customers participating in the TPP when monthly rates are decreased.

Should the Telephone Company increase its rates during the TPP period, the customer will pay the increased rates as long as the increase does not exceed the original rate in effect at the time the customer established service under the TPP.

(4) Adding Nodes to the Ring

If a node is added after the initial installation of the dedicated ring, the new node will carry the same TPP rate as the initial ring and be co-terminus with that TPP. However, if a node is added during the last 12 months or less of a TPP, the customer will be billed the initial TPP ring rate for a minimum period of 12 months.

⁽¹⁾ All term plans for Dedicated SONET Ring Service which are established or renewed after November 9, 2013, for term lengths which are scheduled to expire at any time after February 1, 2019, will instead expire on February 1, 2019. All such services existing on or after February 1, 2019, will be provided on a month-to-month basis at the applicable, then current month-to-month rates. Notwithstanding anything to the contrary in the previous two sentences, this footnote does not apply to any term plans established or renewed after July 15, 2017.

⁽²⁾ Effective on August 21, 2018, AT&T will no longer offer term plans longer than 36 months, (N)
including any renewals, extensions or conversions of existing term commitments. (N)

(5) Renegotiation

The customer may choose to terminate an existing TPP any time prior to the end of the 36- or 60-month period and negotiate a new TPP without termination liability provided the new TPP meets the following requirements:

- (a) The minimum period for the new TPP must be greater than the remaining period currently in effect and
- (b) The renegotiated TPP will be based on the current rates.

An existing 36-month TPP may be converted into a 60-month TPP without termination liabilities, provided that:

- the 36-month TPP has not ended, and
- the converted TPP must be based upon the rates that are currently in effect and otherwise available to all customers.

When the customer converts to a 60-month TPP, actual time in service for the original TPP will be applied to the new TPP. However, no credits or refunds will apply for the billing of actual time in service for the previous TPP.

The customer must meet the following to qualify for the renegotiation clause, without incurring Termination Liability charges⁽¹⁾:

- (1) The customer subscribes to a new higher speed Term Pricing Plan period that is equal to, or greater than 36 months;
- (2) The expiration date for the new Term Pricing Plan period is beyond the end of the original Term Pricing Plan period;
- (3) No lapse in service occurs;
- (4) Nonrecurring Charges will apply;
- (5) The monthly rates for the new service will be those rates in effect at the time the new service is installed;
- (6) The new service is provided between the same customer locations and with the same customer of record as the disconnected service;
- (7) The billed monthly recurring revenue for the new service is equal to or greater than the billed monthly recurring revenue remaining in the service being converted; and
- (8) Spare facilities and equipment must be available or a nonrecurring upfront payment, which is a Special Construction charge, will apply.

(1) This criteria does not apply to term plans purchased prior to 03/18/06.

(6) Renewal

- (a) The customer must provide the Telephone Company with a written notice of intent to renew a TPP no later than 60 days prior to its expiration.
- (b) The customer will continue to be billed at the current TPP rates.
- (c) The new TPP must be for a 36- or 60-month period.
- (d) If the customer does not renew the TPP or does not notify the Telephone Company of its intent to renew the TPP, the Customer's service will convert to the Monthly Extension rate until the customer cancels or renews the service with a new TPP term.

(7) Termination of Service

If a customer cancels a service order or terminates services before the completion of the term for any reason other than a service interruption, the customer agrees to pay the Telephone Company termination liability charges, which are defined below. These charges shall become due as of the effective date of the cancellation or termination and are payable within 30 days of the invoice date, subject to interest penalty on the unpaid balance.

Customer's termination liability for cancellation or termination of service shall be equal to:

- (a) All waived and/or unpaid nonrecurring charges, plus;
- (b) 50% of all recurring charges for the balance of the customer's term.

(D) Moves(1) Moves within a Customer's Premises

A move involves a change in the physical location of the Point of Termination on the customer's premises. Such moves will be treated as an extension of Dedicated SONET Ring facilities. Extension of Dedicated SONET Ring facilities will be provided, at the customer's request, on a time-sensitive charge basis. The labor rates that apply are set forth in Part 2, Section 13 of this Guidebook. There will be no change in the TPP term requirements.

(T)

(2) Moves of Dedicated SONET Ring Nodes

Moves of Dedicated SONET Ring nodes will be provided, at the customer's request, on a time-sensitive charge basis. The charge will not exceed the nonrecurring charge for subsequent installation, as specified in Section 29.4(A), for the specific Dedicated SONET Ring node being modified. The labor rates that apply are set forth in Part 2, Section 13 of this Guidebook. No change in billing period is required.

(T)

(T)

Termination charges will not apply to moves of Dedicated SONET Ring nodes.

(E) Upgrades of Dedicated SONET Ring Service to Higher Speed Services^{(2) (3)} (C)

Customers with 36- or 60-month⁽³⁾ Dedicated SONET Ring Service TPPs may at any time upgrade to a higher speed service (e.g., OC-3 to OC-12), without incurring the Termination Liability charge, providing the following criteria are met: (C)

- (1) The customer subscribes to a new higher speed Term Pricing Plan period that is equal to, or greater than 36 months;⁽³⁾ (C)
- (2) The expiration date for the new Term Pricing Plan period is beyond the end of the original Term Pricing Plan period;
- (3) No lapse in service occurs;
- (4) Nonrecurring Charges will apply;
- (5) The monthly rates for the new service will be those rates in effect at the time the new service is installed;
- (6) The new service is provided between the same customer locations and with the same customer of record as the disconnected service;
- (7) The billed monthly recurring revenue for the new service is equal to or greater than the billed monthly recurring revenue remaining in the service being converted;
- (8) Spare facilities and equipment must be available or a nonrecurring upfront payment, which is a special construction charge, will apply; and
- (9) Existing service must have been in place for a minimum of 12 months.⁽¹⁾

⁽¹⁾ This criteria does not apply to term plans purchased prior to 03/18/06.

⁽²⁾ All term plans for Dedicated SONET Ring Service which are established or renewed after November 9, 2013, for term lengths which are scheduled to expire at any time after February 1, 2019, will instead expire on February 1, 2019. All such services existing on or after February 1, 2019, will be provided on a month-to-month basis at the applicable, then current month-to-month rates. Notwithstanding anything to the contrary in the previous two sentences, this footnote does not apply to any term plans established or renewed after July 15, 2017.

⁽³⁾ Effective on August 21, 2018, AT&T will no longer offer term plans longer than 36 months, including any renewals, extensions or conversions of existing term commitments. (N)
(N)

(F) Conversion to Dedicated SONET Ring Service from Other Services

Customers may convert one of the following existing services to Dedicated SONET Ring Service without incurring the Termination Liability charges for those existing services as long as the minimum requirements in that section of the Guidebook for waiver of the Termination Liability charges of that section are met. The STN, DS3, OCN Point-to-Point Service and ReliaNet sections will depict applicable termination liability exemptions. (D)

The following services found in Tariff F.C.C. No. 73 and this Guidebook may be upgraded to Dedicated SONET Ring:

- Self-Healing Transport Network (STN): Tariff F.C.C. No. 73, Section 19.3.15(A) (1) (c) (T)
(D)
(D)
- Megalink Custom (DS3): Tariff F.C.C. No. 73, Section 20.4.6
- ReliaNet: Tariff F.C.C. No. 73, Section 31.3.2(K) (1) (b) (T)
- Optical Carrier Network Point-to-Point: Part 9, Section 40 of this Guidebook

The customer must meet the following to qualify for conversions without incurring Termination Liability charges⁽¹⁾:

- (1) The customer subscribes to a new higher speed Term Pricing Plan period that is equal to, or greater than, 36 months;
- (2) The expiration date for the new Term Pricing Plan period is beyond the end of the original Term Pricing Plan period;
- (3) No lapse in service occurs;
- (4) Nonrecurring Charges will apply;
- (5) The monthly rates for the new service will be those rates in effect at the time the new service is installed;
- (6) The new service is provided between the same customer locations and with the same customer of record as the disconnected service;
- (7) The billed monthly recurring revenue for the new service is equal to or greater than the billed monthly recurring revenue remaining in the service being converted; and
- (8) Spare facilities and equipment must be available or a nonrecurring upfront payment, which is a Special Construction charge, will apply.

(1) This criteria does not apply to term plans purchased prior to 03/18/06.

(D)
(D)

(G) Shared Network Arrangement⁽¹⁾

A Shared Network Arrangement is a service offering that enables a customer ("Service User") to connect subtending services to an OC-3, OC-12 or OC-48 Dedicated SONET Ring service of another customer (the "Host Subscriber"), with the Telephone Company maintaining separate billing for each. Each customer will be billed for those rate elements associated with their own portion of the service configuration. The Host Subscriber will be responsible for all Dedicated SONET Ring Service rate elements (for example, node, ports and mileage, etc). Under no circumstances will the rates or charges for individual rate elements be split. This offering is limited to service configurations where a Service User orders a subtending service dropped from a Host subscriber's Dedicated SONET Ring wire center node.

Under the Shared Network Arrangement, the Telephone Company may share record information with the Host Subscriber pertaining to the services of other users of the shared network. Such disclosure will be under the sole discretion of the Telephone Company and is necessary to perform billing reconciliation and/or other functions required in connection with maintaining account records.

(H) Shared Use

Shared Use occurs when Switched Access and Special Access services are provided over the same analog or digital high capacity facility or SONET based service through a common interface. The conditions governing the provision of Shared Use are set forth in 6.8.12 of Tariff F.C.C. No. 73.

While Shared Use of SONET facilities (i.e., Dedicated SONET Ring Service) for Switched Access Transport is permitted, the SONET Special Access facilities continue to be rated as Special Access.

(1) Effective 05/26/06, this condition is limited to existing customers. For new customers purchasing Shared Network Arrangement, terms and conditions set forth in Section 5.2.2 (Z) of Tariff F.C.C. No. 73, will apply.

(I) Re-Map Service ⁽¹⁾

(N)

Re-Map Service is provided in conjunction with Dedicated SONET Ring Service and allows for a pre-defined set of services to be rerouted by the Telephone Company from one customer premises node to another customer premises node (defined as a "Re-Map node") in the event of a customer premises disaster. Re-Map Service will be tested at initial installation and once each year thereafter. Additional testing can be requested and will be charged on a per test basis. Activation upon customer request in the event of an emergency will be charged on a per occurrence basis.

Once the customer notifies the Telephone Company that they are ready to receive signals to the re-map node site the Telephone Company will re-map up to 50 circuits within the initial hours and 20 circuits every hour thereafter. The Emergency Activation Nonrecurring Charge will not be applied if the first 50 circuits are not remapped within 4 hours due to a Telephone Company caused delay.

Re-Map testing or activation for OC-3 or OC-12 DDN service requires a minimum of one DS1 (VT1.5), or 1 DS3 (STS-1) between one customer premises node and the Re-Map node. Re-Map testing or activation for OC-12 or OC-48 service requires a minimum incremental group from 1 to 28 DS1s or one DS3 (equals one STS-1) between one customer premises node and the Re-Map node.

The emergency Re-Map activation configuration will be maintained for up to 30 days. After 30 days, if the customer wishes to maintain the emergency configuration, the emergency activation NRC will be applied once for each 30 day additional period.

Re-Map Service is available on Self-Healing Uni-Directional Path Switched Rings (UPSR) only.

(J) Ethernet over SONET (EoS)

Effective September 5, 2003, new orders for Dedicated SONET Ring Service with the EoS enhancement will be served by different equipment than the equipment used for customers who placed Dedicated SONET Ring Service orders that were completed prior to September 5, 2003. Customers subscribing to Dedicated SONET Ring Service prior to September 5, 2003 requesting a change to the new equipment will incur termination liability charges for their existing service. Disconnect of the existing Dedicated SONET Ring Service and placement of an order for new Dedicated SONET Ring Service with the EoS enhancement is required. The monthly rates for the new service(s) shall be those rates in effect at the time the new service(s) are installed.

⁽¹⁾ Effective August 1, 2013, availability of Re-Map nodes is limited to Re-Map nodes that are in service or have been ordered prior to August 1, 2013. (N)
(N)

(K) STS-1 Service

The STS-1 circuit allows the efficient transport of up to 51.84 Mbps of bandwidth across Dedicated SONET Ring utilizing EC-1 (Electrical Connection - Level 1) ports on the dedicated service. While the EC-1 port is comparable to the DS-3 port as far as the connection capacity per STS, the STS-1 circuit utilizes the entire bandwidth of the STS (51.84 Mbps) while the DS-3 uses 44.76 Mbps of the STS. The STS-1 circuit is available via EC-1 ports on OC-3, OC-12 and OC-48 rings.

(L) Unprotected Channel Transport (UCT)

UCT will allow customers to transport traffic (DS-1, DS-3, up to OC-48), over a ring without enabling SONET protection schemes. This is intended for applications in which the customer provides protection for the circuit through means other than those available through SONET. If a fault occurs on the ring along the transport path, the traffic will not be switched to a protection channel. Service will be interrupted on that circuit until the fault is corrected. The customer is required to call in and open a trouble ticket for the unprotected service. If a fault occurs in the ring, but does not occur along the transport route, service will not be interrupted on that circuit.

Customers who order Dedicated SONET Ring Service may need to replace or upgrade their existing service to invoke use of UCT for circuit assignments. Use of UCT is managed through a Special Routing Code (SRC) in relation to a circuit's Connecting Facility Assignment (CFA). When an Unprotected service is placed on a channel, the protection switching is shut off. When a UCT is disconnected, the channel will revert back to the standard protection mode.

(M)⁽¹⁾ Upgrade to Next Generation SONET equipment (required for Ethernet ports)

Customers with three or five-year OPPs may at any time upgrade to Next Generation equipment without incurring Termination Liability charges, providing the following criteria are met:

- The customer subscribes to a Term Plan period that is equal to, or greater than thirty-six months;
- The expiration date for the new Term Plan period is beyond the end of the original Optional Payment Plan period;
- No lapse in service occurs;
- Nonrecurring charges will apply, when applicable;
- The monthly rates for the new service(s) will be those rates in effect at the time the new service(s) is/are installed;
- The new service is provided between the same customer locations and with the same customer of record as the disconnected service;
- The original location of all nodes must be included in the new service.
- Billed recurring revenue for each month of the first eighteen months of the new service is equal to or greater than the billed recurring revenue for the last month of the service(s) being converted.

⁽¹⁾ This option is limited to existing customers at existing locations purchased between September 5, 2003 and March 12, 2004.

-
- (N) Upgrade to a higher speed Dedicated SONET Ring Service with Next Generation SONET equipment (required for Ethernet ports)

Customers with three or five-year OPPs may at any time upgrade to a higher speed Dedicated SONET Ring Service with Next Generation equipment without incurring Termination Liability charges, providing the following criteria are met:

- (1) The customer subscribes to a Term Plan period that is equal to, or greater than thirty-six months;
- (2) The expiration date for the new Term Plan period is beyond the end of the original Optional Payment Plan period;
- (3) No lapse in service occurs;
- (4) Nonrecurring charges will apply;
- (5) The monthly rates for the new service(s) will be those rates in effect at the time the new service(s) is/are installed;
- (6) The new service is provided between the same customer locations and with the same customer of record as the disconnected service;
- (7) The original location of all nodes must be included in the new service;
- (8) Billed recurring revenue for each month of the first eighteen months of the new service is equal to or greater than the billed recurring revenue for the last month of the service(s) being converted; and
- (9) Existing service must have been in place for a minimum of 12 months.⁽¹⁾

(1) This criteria does not apply to term plans purchased prior to 03/18/06.

(0) Jointly Provided Service

(N)

(1) General

DSRS may be available in a meet-point billing arrangement involving another Incumbent Local Exchange Carrier (ILEC) (sometimes also referred to as an Independent Company or ICO), where suitable facilities exist and where appropriate procedures for such arrangement have been put in place between the Telephone Company and the other ILEC. When the Telephone Company and another ILEC jointly provide a meet-point ring arrangement, each ILEC involved shall provision and bill the portion of service located in its operating territory according to the terms and conditions of that ILEC's applicable tariffs or other service publications. Meet-point billing arrangements are not available for OC-3 DSRS.

(2) Ordering

The Customer shall order DSRS Service by issuing an access order, or by such other means for the exchange telephone companies to provision on the ring in each exchange telephone company territory. The Customer will place the order for service as set forth in the ordering conditions for the requested service.

(3) Credit Allowance for Service Interruption

DSRS, provided in a meet-point arrangement, is subject to the general terms and conditions in Part 2, Section 2, including, without limitation, the exclusions applicable to Credit Allowances for Service Interruptions, as provided in Part 2, Section 2.5.6(F). As clarification, but not to modify any such terms and conditions, a Credit Allowance for Service Interruptions shall not apply to any service interruption resulting from any failure attributable to the other ILEC jointly providing the service or otherwise not attributable to the Telephone Company.

(N)

29.4 Rates and Charges

(A) Node					
Description	USOC	36 Months ⁽³⁾	60 Months ^{(3) (4)}	Monthly Extension	(C)
Per Node:					
OC-3					
-Customer Premises					
First	FP5CX	\$1,770.00	\$1,415.00	\$2,120.00	
First Re-Map ⁽²⁾	RN8CX	1,770.00	1,415.00	2,120.00	
Additional	FP5CA	1,000.00	800.00	1,200.00	
Additional Re-Map ⁽²⁾	RN8CA	1,000.00	800.00	1,200.00	
-Central Office	FC5CX	1,000.00	800.00	1,200.00	
OC-12					
-Customer Premises					
First	FP5DX	3,850.00	3,080.00	4,620.00	
First Re-Map ⁽²⁾	RN8DX	3,850.00	3,080.00	4,620.00	
Additional	FP5DA	2,620.00	2,095.00	3,140.00	
Additional Re-Map ⁽²⁾	RN8DA	2,620.00	2,095.00	3,140.00	
-Central Office	FC5DX	2,620.00	2,095.00	3,140.00	
Direct Drop ⁽²⁾					
-Customer Premises					
First	L8NDX	3,750.00	2,980.00	4,470.00	
First Re-Map ⁽²⁾	RL8DX	3,750.00	2,980.00	4,470.00	
Additional	L8NDA	2,520.00	1,995.00	2,990.00	
Additional Re-Map ⁽²⁾	RL8DA	2,520.00	1,995.00	2,990.00	
-Central Office	L9NDX	2,520.00	1,995.00	2,990.00	
OC-48					
-Customer Premises					
First	FP5EX	5,890.00	4,715.00	7,070.00	
First Re-Map ⁽²⁾	RN8EX	5,890.00	4,715.00	7,070.00	
Additional	FP5EA	5,240.00	4,190.00	6,280.00	
Additional Re-Map ⁽²⁾	RN8EA	5,240.00	4,190.00	6,280.00	
Plus ⁽¹⁾	FP5SX	5,240.00	4,190.00	6,280.00	
Plus Re-Map ^{(1) (2)}	RN8SX	5,240.00	4,190.00	6,280.00	
-Central Office	FC5EX	5,240.00	4,190.00	6,280.00	
-Central Office Plus ⁽¹⁾	FC5SX	4,870.00	3,900.00	6,850.00	

Description	USOC	Nonrecurring Charge
Nonrecurring charges for subsequent installation		
-Per Node		
Customer Premises	NRBS7	\$400.00
Customer Premises Re-Map ⁽²⁾	NRBS7	400.00
Central Office	NRBSV	325.00

(1) Effective 03/18/06, the OC-48 "Plus" and Direct Drop Node feature will no longer be available to new customers. There will be no change to existing customers.

(2) Effective August 1, 2013, availability of Re-Map nodes is limited to Re-Map nodes that are in service or have been ordered prior to August 1, 2013.

(3) All term plans for Dedicated SONET Ring Service which are established or renewed after November 9, 2013, for term lengths which are scheduled to expire at any time after February 1, 2019, will instead expire on February 1, 2019. All such services existing on or after February 1, 2019, will be provided on a month-to-month basis at the applicable, then current month-to-month rates. Notwithstanding anything to the contrary in the previous two sentences, this footnote does not apply to any term plans established or renewed after July 15, 2017.

(4) Effective on August 21, 2018, AT&T will no longer offer term plans longer than 36 months, including any renewals, extensions or conversions of existing term commitments. (N)

Description	USOC	36 Months ⁽¹⁾	60 Months ^{(1) (2)}	Monthly Extension	(C)
Per node:					
Flex-Ring					
Customer Premise node for 2nd ring double on existing					
OC-12	GP5FX	2,200.00	1,800.00	2,900.00	
OC-48	GP5GX	3,900.00	3,000.00	4,500.00	
Central Office node for 2nd ring double on existing					
OC-12	GC5FX	1,850.00	1,500.00	2,200.00	
OC-48	GC5GX	3,500.00	2,800.00	4,100.00	

⁽¹⁾ All term plans for Dedicated SONET Ring Service which are established or renewed after November 9, 2013, for term lengths which are scheduled to expire at any time after February 1, 2019, will instead expire on February 1, 2019. All such services existing on or after February 1, 2019, will be provided on a month-to-month basis at the applicable, then current month-to-month rates. Notwithstanding anything to the contrary in the previous two sentences, this footnote does not apply to any term plans established or renewed after July 15, 2017.

⁽²⁾ Effective on August 21, 2018, AT&T will no longer offer term plans longer than 36 months, including any renewals, extensions or conversions of existing term commitments. (N)
 (N)

(B) OC-48 Add/Drop Capability

Description	USOC	36 Months ⁽⁵⁾	60 Months ^{(5) (6)}	Monthly Extension (C)
Per Node	MPEFX	\$3,510.00	\$2,895.00	\$4,350.00
Re-Map ⁽⁴⁾	M8RFX	3,510.00	2,895.00	4,350.00
per node				
Plus ⁽³⁾	MPEPX	3,120.00	2,575.00	3,870.00
per node				
Plus Re-Map ^{(3) (4)}	M8RPX	3,120.00	2,575.00	3,870.00
per node				
Nonrecurring charges for Subsequent Installation - per arrangement	NRBS8			490.00

(C) Ports

Description	USOC	36 Months ⁽⁵⁾	60 Months ^{(5) (6)}	Monthly Extension (C)
- Per Node Type (excluding Re-Map)				
DS1 at OC-3 Node	SPRAX	\$ 50.00	\$ 45.00	\$ 65.00
DS3 at OC-3 Node	SPRBX	120.00	110.00	150.00
EC-1 at OC-3 Node	S9NSX	120.00	110.00	150.00
OC-3 at OC-3 Node	S9T1X	350.00	300.00	550.00
DS3 at OC-12 (DDN) ⁽³⁾	SPRMX	120.00	110.00	150.00
EC-1 at OC-12 (DDN) ⁽³⁾	S9NTX	120.00	110.00	150.00
DS3 at OC-12 Node	SPRCX	120.00	110.00	150.00
EC-1 at OC-12 Node	S9NUX	120.00	110.00	150.00
OC-3 or OC-3c at OC-12 Node	SPREX	150.00	135.00	190.00
DS1 at OC-12 (DDN) ⁽¹⁾⁽³⁾	SPRNX	50.00	45.00	65.00
DS1 at OC-12 Node ⁽¹⁾⁽²⁾	SPRGX	50.00	45.00	65.00
OC-12 at OC-12 Node	S9T2X	850.00	725.00	1050.00
OC-12 or OC-12c at OC-48 Node	SPRHX	375.00	360.00	475.00
OC-3 or OC-3c at OC-48 Node	SPRJX	150.00	135.00	190.00
DS3 at OC-48 Node	SPRKX	120.00	110.00	150.00
EC-1 at OC-48 Node	S9NVX	120.00	110.00	150.00
DS1 at OC-48 Node ⁽¹⁾	SPRLX	50.00	45.00	65.00
OC-48 at OC-48 Node	S9T3X	1900.00	1650.00	2850.00
DS3 with Transmux	S4NGX	250.00	200.00	300.00
100 Mbps Ethernet (STS-1) at OC-3 Node*	S9TAX	145.00	130.00	225.00
100 Mbps Ethernet (STS-1) at OC-12 Node*	S9TBX	145.00	130.00	225.00
100 Mbps Ethernet (STS-3c) at OC-12 Node*	S9TCX	180.00	160.00	280.00
1 Gbps Ethernet (STS-1) at OC-12 Node*	S9TDX	250.00	200.00	350.00
1 Gbps Ethernet (STS-3c) at OC-12 Node*	S9TEX	250.00	200.00	350.00
100 Mbps Ethernet (STS-1) at OC-48 Node*	S9TGX	145.00	130.00	225.00
100 Mbps Ethernet (STS-3c) at OC-48 Node*	S9THX	180.00	160.00	280.00
1 Gbps Ethernet (STS-1) at OC-48 Node*	S9TJX	250.00	200.00	350.00
1 Gbps Ethernet (STS-3c) at OC-48 Node*	S9TKX	250.00	200.00	350.00
1 Gbps Ethernet (STS-12c) at OC-48 Node*	S9TLX	600.00	500.00	875.00
1 Gbps Ethernet (STS-24c) at OC-48 Node*	S9TMX	900.00	850.00	1500.00

(1) Optical to Electrical DS1 add/drop capability as described in 29.3(A) (5) is needed along with an OC-3 port unless the customer has chosen an OC-12 DDN.

(2) The Optical-to-Electrical DS1 add/drop capability will be charged when the 85th DS1 port is applied per OC-12 node.

(3) Effective 03/18/06, the OC-48 "Plus" and Direct Drop Node feature will no longer be available to new customers. There will be no change to existing customers.

(4) Effective August 1, 2013, availability of Re-Map nodes is limited to Re-Map nodes that are in service or have been ordered prior to August 1, 2013.

(5) All term plans for Dedicated SONET Ring Service which are established or renewed after November 9, 2013, for term lengths which are scheduled to expire at any time after February 1, 2019, will instead expire on February 1, 2019. All such services existing on or after February 1, 2019, will be provided on a month-to-month basis at the applicable, then current month-to-month rates. Notwithstanding anything to the contrary in the previous two sentences, this footnote does not apply to any term plans established or renewed after July 15, 2017.

(6) Effective on August 21, 2018, AT&T will no longer offer term plans longer than 36 months, including any renewals, extensions or conversions of existing term commitments. (N)

* Effective September 5, 2003, new orders for Dedicated SONET Ring Service with the EoS enhancement will be served by different equipment. Disconnect of the existing Dedicated SONET Ring Service and placement of an order for new Dedicated SONET Ring Service with the EoS enhancement is required. Refer to Section 29.3(J) for details.

Description	USOC	36 Months ⁽⁶⁾	60 Months ^{(6) (7)}	Monthly Extension	(C)
EoS Ports					
Virtual Concatenation (VCAT) ⁽¹⁾					
- per multiplexing function					
10/100 BaseT Ethernet Port	S5P1X	250.00	180.00	350.00	
Bandwidth options for port ^{(2) (4) (5)}					
VT1.5-1v (1.6 Mbps)					
VT1.5-2v (3.2 Mbps)					
VT1.5-3v (4.8 Mbps)					
VT1.5-4v (6.4 Mbps)					
VT1.5-5v (8.0 Mbps)					
VT1.5-6v (9.6 Mbps)					
VT1.5-7v (11.2 Mbps)					
VT1.5-8v (12.4 Mbps)					
VT1.5-10v (16.0 Mbps)					
VT1.5-13v (20.8 Mbps)					
STS-1-1v (48.38 Mbps)					
STS-1-2v (96.77 Mbps)					
1000 Base SX Ethernet Port	S5P2X	425.00	350.00	500.00	
1000 Base LX Ethernet Port	S5P3X	425.00	350.00	500.00	
Bandwidth options for port ^{(3) (4) (5)}					
STS-1-1v (48.38 Mbps)					
STS-1-2v (96.77 Mbps)					
STS-1-3v (145.15 Mbps)					
STS-1-4v (193.54 Mbps)					
STS-1-5v (241.92 Mbps)					
STS-1-6v (290.30 Mbps)					
STS-1-9v (435.46 Mbps)					
STS-1-12v (580.61 Mbps)					
STS-1-21v (1016.06 Mbps)					
STS-3c-1v (149.76 Mbps)					
STS-3c-2v (299.52 Mbps)					
STS-3c-3v (449.28 Mbps)					
STS-3c-4v (599.04 Mbps)					
STS-3c-7v (1048.32 Mbps)					

⁽¹⁾ Nonrecurring charges apply to EoS ports, Virtual Concatenation (VCAT). See Port charges in Section 29.4(C), for applicable nonrecurring charges.

⁽²⁾ Actual payload capacity for selected bandwidth.

⁽³⁾ Actual payload capacity for selected bandwidth applies to both SX and LX.

⁽⁴⁾ Only Single-Mode Fiber is available in the Central Office.

⁽⁵⁾ The EoS line rates defined herein are based on the theoretical SONET payload rates as per GR-253-CORE, Issue 4. These values are not representative of the true Ethernet transport capacity of the EoS circuit.

⁽⁶⁾ All term plans for Dedicated SONET Ring Service which are established or renewed after November 9, 2013, for term lengths which are scheduled to expire at any time after February 1, 2019, will instead expire on February 1, 2019. All such services existing on or after February 1, 2019, will be provided on a month-to-month basis at the applicable, then current month-to-month rates. Notwithstanding anything to the contrary in the previous two sentences, this footnote does not apply to any term plans established or renewed after July 15, 2017.

⁽⁷⁾ Effective on August 21, 2018, AT&T will no longer offer term plans longer than 36 months, including any renewals, extensions or conversions of existing term commitments. (N)

Description	USOC	36 Months ⁽⁴⁾	60 Months ^{(4) (5)}	Monthly Extension	(C)
Per DS1 Re-Map Block ⁽³⁾ (consists of 28 DS1 ports) at					
OC-3 Ring	P8RAX	1,400.00	1,260.00	1,820.00	
OC-12 Ring	P8RGX	1,400.00	1,260.00	1,820.00	
OC-12 DDN Ring ⁽¹⁾	P8RNX	1,400.00	1,260.00	1,820.00	
OC-48 Ring	P8RLX	1,400.00	1,260.00	1,820.00	
Per DS3 Re-Map Port ⁽³⁾ at					
OC-3 Ring	P8RBX	120.00	110.00	150.00	
OC-12 DDN Ring ⁽¹⁾	P8RMX	120.00	110.00	150.00	
Per DS3 Re-Map Block ⁽³⁾ (consists of 3 DS3 ports) at					
OC-12 Ring	P8RCX	360.00	330.00	450.00	
OC-48 Ring	P8RKX	360.00	330.00	450.00	
Per DS3 Transmux Re-Map ^{(2) (3)}					
	RN7TX	250.00	200.00	300.00	
Per EC-1 Re-Map Port ⁽³⁾ at					
OC-3 Ring	S9N6X	120.00	110.00	150.00	
OC-12 Ring	S9N8X	120.00	110.00	150.00	
OC-48 Ring	S9N9X	120.00	110.00	150.00	
Per OC-3, OC-3c Re-Map Port ⁽³⁾ at					
OC-12 Ring	P8REX	150.00	135.00	190.00	
OC-48 Ring	P8RJX	150.00	135.00	190.00	
Per OC-12, OC-12c Re-Map Port ⁽³⁾ at OC-48 Ring					
	P8RHX	375.00	360.00	475.00	

⁽¹⁾ Effective 03/18/06, the Direct Drop Node feature will no longer be available to new customers. There will be no change to existing customers.

⁽²⁾ Available for rings established on or after 10/17/06.

⁽³⁾ Effective August 1, 2013, availability of Re-Map nodes is limited to Re-Map nodes that are in service or have been ordered prior to August 1, 2013.

⁽⁴⁾ All term plans for Dedicated SONET Ring Service which are established or renewed after November 9, 2013, for term lengths which are scheduled to expire at any time after February 1, 2019, will instead expire on February 1, 2019. All such services existing on or after February 1, 2019, will be provided on a month-to-month basis at the applicable, then current month-to-month rates. Notwithstanding anything to the contrary in the previous two sentences, this footnote does not apply to any term plans established or renewed after July 15, 2017. Notwithstanding anything to the contrary in the previous two sentences, this footnote does not apply to any term plans established or renewed after July 15, 2017.

⁽⁵⁾ Effective on August 21, 2018, AT&T will no longer offer term plans longer than 36 months, including any renewals, extensions or conversions of existing term commitments. (N)
(N)

Description	USOC	Nonrecurring Charge
Nonrecurring charges for subsequent installation		
- Per port type		
OC-48	NRBN9	\$425.00
OC-12 or OC-12c	NRBSZ	400.00
OC-3 or OC-3c	NRBSW	400.00
EC-1	NRBSX	385.00
DS3	NRBSX	385.00
DS3 w/Transmux	NRBSX	385.00
DS1	NRBSY	350.00
100 Mbps Ethernet STS-1*	NRM63	385.00
100 Mbps Ethernet STS-3c*	NRM64	385.00
1 Gbps Ethernet STS-1*	NRM65	425.00
1 Gbps Ethernet STS-3c*	NRM66	425.00
1 Gbps Ethernet STS-12c*	NRM67	425.00
1 Gbps Ethernet STS-24c*	NRM68	425.00
10/100 BaseT Ethernet Port	NRM63	385.00
1000 BaseLX Ethernet Port	NRM65	425.00
1000 BaseSX Ethernet Port	NRM66	425.00

(D) Mileage

Description	USOC	36 Months ⁽²⁾	60 Months ^{(2) (3)}	Monthly Extension	(C)
Per mile between nodes by ring type					
OC-3	1YAZX	\$260.00	\$220.00	\$330.00	
OC-12	1YAZX	260.00	220.00	330.00	
OC-48	1YAZX	260.00	220.00	330.00	

(E) Optical to Electrical DS1 Add/Drop Capability

Description	USOC	36 Months ⁽²⁾	60 Months ^{(2) (3)}	Monthly Extension	(C)
Per OC-3 to DS1 Add/Drop Re-Map ⁽¹⁾	MXJDX	875.00	700.00	1,050.00	
Per OC-3 to DS-1 Add/Drop	M8RDX	875.00	700.00	1,050.00	

Description	USOC	Nonrecurring Charge
Nonrecurring charges for subsequent installation		
-Per OC-3 to DS1 Add/Drop	NRBS6	\$490.00

* Effective September 5, 2003, new orders for Dedicated SONET Ring Service with the EoS enhancement will be served by different equipment. Disconnect of the existing Dedicated SONET Ring Service and placement of an order for new Dedicated SONET Ring Service with the EoS enhancement is required. Refer to Section 29.3(J) for details.

⁽¹⁾ Effective August 1, 2013, availability of Re-Map nodes is limited to Re-Map nodes that are in service or have been ordered prior to August 1, 2013.

⁽²⁾ All term plans for Dedicated SONET Ring Service which are established or renewed after November 9, 2013, for term lengths which are scheduled to expire at any time after February 1, 2019, will instead expire on February 1, 2019. All such services existing on or after February 1, 2019, will be provided on a month-to-month basis at the applicable, then current month-to-month rates. Notwithstanding anything to the contrary in the previous two sentences, this footnote does not apply to any term plans established or renewed after July 15, 2017.

⁽³⁾ Effective on August 21, 2018, AT&T will no longer offer term plans longer than 36 months, including any renewals, extensions or conversions of existing term commitments. (N)

(F) Dedicated SONET Ring Regenerator

Description	USOC	36 Months ⁽¹⁾	60 Months ⁽¹⁾⁽²⁾	Monthly Extension	(C)
OC-3 Each (as required)	RGY	\$1,000.00	\$ 800.00	\$1,200.00	
OC-12 Each (as required)	RGY	2,620.00	2,095.00	3,140.00	
OC-48 Each (as required)	RGY	3,275.00	2,620.00	3,930.00	

Description	USOC	Nonrecurring Charge
Nonrecurring charges for subsequent installation of Regenerator -Each (as required)	NRBS5	\$270.00

(G) Shared Network Arrangement

Description	USOC	Nonrecurring Charge
Processing Charge Per Service Order	NRMCL	\$30.00

(H) Installation and Rearrangement Charges

Description	USOC	Administrative Charge per Order	Design and Central Office Connection Charge, per Initial Ring
OC-3		ORCMX	NRMCK
		\$60.00	\$600.00
OC-12		60.00	600.00
OC-48		60.00	600.00
STS-1		60.00	

⁽¹⁾ All term plans for Dedicated SONET Ring Service which are established or renewed after November 9, 2013, for term lengths which are scheduled to expire at any time after February 1, 2019, will instead expire on February 1, 2019. All such services existing on or after February 1, 2019, will be provided on a month-to-month basis at the applicable, then current month-to-month rates. Notwithstanding anything to the contrary in the previous two sentences, this footnote does not apply to any term plans established or renewed after July 15, 2017.

⁽²⁾ Effective on August 21, 2018, AT&T will no longer offer term plans longer than 36 months, including any renewals, extensions or conversions of existing term commitments. (N)
(N)

Description	USOC	Nonrecurring Charge	
Re-Map Service ⁽²⁾			(N)
Initial Service Script Establishment/ Test Charge			
Per OC-3 Ring	NRMR1	\$2,000.00	
Per OC-12 Ring	NRMR1	3,500.00	
Per OC-12 DDN Ring ⁽¹⁾	NRMR2	2,000.00	
Per OC-48 Ring	NRMR1	4,500.00	
Subsequent Script Activity Charge			
Per OC-3 Ring	NRMR3	1,200.00	
Per OC-12 Ring	NRMR3	2,100.00	
Per OC-12 DDN Ring ⁽¹⁾	NRMR4	1,200.00	
Per OC-48 Ring	NRMR3	2,700.00	
Scheduled Test Charge			
Per OC-3 Ring	NRMR5	1,600.00	
Per OC-12 Ring	NRMR5	2,800.00	
Per OC-12 DDN Ring ⁽¹⁾	NRMR6	1,600.00	
Per OC-48 Ring	NRMR5	3,600.00	
Emergency Re-Map Activation (per request)			
Per OC-3 Ring	NRMR7	1,800.00	
Per OC-12 Ring	NRMR7	3,150.00	
Per OC-12 DDN Ring ⁽¹⁾	NRMR8	1,800.00	
Per OC-48 Ring	NRMR7	4,050.00	

⁽¹⁾ Effective 03/18/06, the Direct Drop Node feature will no longer be available to new customers. There will be no change to existing customers.

⁽²⁾ Effective August 1, 2013, availability of Re-Map nodes is limited to Re-Map nodes that are in service or have been ordered prior to August 1, 2013. (N)
(N)