

ACCESS SERVICE

7. Special Access Service

7.2 Service Descriptions

7.2.5 Video Service

Video Services are full motion video transport services that deliver high quality video images and stereo quality audio. There are two digital video transport offerings: Serial Component Video Service (SCVS), the first generation for delivering a high definition video signal, and High Definition Video Transport (HDVT), the second generation.

(A) Basic Channel Description

(1) Serial Component Video Service (SCVS)

SCVS is a standards based 270 Mbps digital video transport for the limited purpose of providing one-way transport of high quality digital video signals and audio signals. (C)

The following standard formats are supported:

- (a) Serial Digital Interface (SDI) - ANSI/Society of Motion Picture and Television Engineers (SMPTE 259M); (C)

Audio embedding of either four analog audio channels at 20 KHz or two AES-EBU digital audio channels is available from the Telephone Company. (N)
(N)
(N)

- (b) Serial Data Transport Interface (SDTI SMPTE 305M); and

- (c) Digital Video Broadcasting-Asynchronous Serial Interface (DVB-ASI).

The customer is responsible for combining multiple MPEG video program stream(s) into a transport stream and encapsulating this into a 270 Mbps DVB-ASI format.

(D)
(D)

SVCS is available on a point-to-point basis, or between a customer premises and a Telephone Company Hub location, where available.

(T)
(D)

(D)

(2) High Definition Video Transport (HDVT)

HDVT provides one-way transmission of a digital video signal between customer designated premises or between customer designated premises and a Telephone Company Hub (where available) via fiber optic facilities.

The following standard formats are supported:

- (a) SMPTE 292M (1.485 Gbps);
- (b) SMPTE 310M (19.39Mbps);
- (c) ANSI/Society of Motion Picture and Television Engineers (SMPTE 259M);
- (d) Serial Data Transport Interface (SDTI SMPTE 305M); and
- (e) Digital Video Broadcasting-Asynchronous Serial Interface (DVB-ASI).

The customer can transmit video signals using any of the standard formats listed above; the network terminating equipment is designed to automatically detect and send the correct format.

HDVT will support the transport of digital video with or without embedded audio. Audio embedding or de-bedding is the customer responsibility.

HDVT is provided where facilities are available. Where facilities are not available, Special Construction charges may apply as specified in Part 1, Section 8 of this Guidebook.

(B) Optional Features and Functions

(1) Video Regenerator

Video Regenerators provide for the regeneration of the digital video signals. The Video Regenerator is available for Serial Component Video Service (SCVS) and High Definition Video Transport (HDVT). A Video Regenerator will be required for SCVS or HDVT when the distance between the designated SCVS or HDVT end user premises is greater than the single system optical power budget.

(2) Optical, Wavelength and Ethernet Handoff Options and Interfaces (C)

(a) Optical, Wavelength and Ethernet Handoff Options (C)

These options are available with SCVS and HDVT. The Telephone Company will encapsulate the Customer's digital video signal into an Optical (e.g., OC-3c or OC-12c), Wavelength or Ethernet transport stream. The service will either (i) originate as an electrical or standards-based SCVS or HDVT video signal at one end, and terminate as an Optical, Wavelength or Ethernet signal at the other end, or (ii) originate as an Optical, Wavelength or Ethernet signal at one end, and terminate as an electrical or standards-based SCVS or HDVT video signal at the other end. The available bandwidths for the Optical, Wavelength and Ethernet handoffs and the rates payable therefore are listed in the Rates and Charges section (Section 7.5(b)).

(C)
(D)

(B) Optional Features and Functions (Cont'd)

(2) Optical, Wavelength and Ethernet Handoff Options and Interfaces (C)
(Cont'd)

(a) (Cont'd)

In certain conditions where facilities are available, the Telephone Company may design transport streams to deliver multiple SCVS or HDVT circuits in the same Optical, Wavelength or Ethernet transport stream, to or from the Customer venue. This design is subject to the availability of suitable bandwidth in the Telephone Company's network.

(C)
|
(C)
(D)

(b) SMPTE 310M Digital Interface - SCVS

This interface is available with SCVS and provides Customers with the ability to handoff a standard 19.4 Mbps SMPTE 310M interface at the transmit end of the SCVS circuit. The Telephone Company's output at the other end will be a 270 Mbps DVB-ASI video signal.

(c) NTSC Analog Interface - SCVS

This interface is available with SCVS and provides Customers with the ability to have an NTSC interface with up to four analog audio channels at 20 KHz at one end of the service. This option is available at either end of the SCVS circuit. The interface at the other end will be an SDI video signal, as described in the SCVS service description above.

(d) Multi Media Channel - HDVT

Multi Media Channel (MMC) enables Customers of HDVT service to transmit up to 1 Gbps of data via a point-to-point data channel. Customers must subscribe to at least one HDVT circuit to use the MMC feature.

The MMC feature provides a Layer 2 (Ethernet) data channel with a specified capacity of up to 1 Gbps between the same two locations as the HDVT circuit with which it is associated.

The MMC handoff may be optical or electrical depending on the service requested and equipment available. If the associated HDVT circuit has been purchased with an Optical, Wavelength or Ethernet Handoff option, the handoff to the Customer of the HDVT circuit and the associated MMC feature will be a single encoded video/data transport stream. The combined bandwidth of the HDVT circuit and the associated MMC feature cannot exceed the available bandwidth of the applicable Optical, Wavelength or Ethernet Handoff option purchased by the Customer.

(C)
(C)
(C)
(C)

Customers requesting MMC associated with an HDVT circuit and the Optical, Wavelength or Ethernet option will be responsible for doing their own encoding or decoding at the optical handoff end.

(C)
(C)
(D)

Customers may only use the MMC to transport data content related to the video content being transported on the associated HDVT circuit (and other HDVT circuits between the same two locations).

(B) Optional Features and Functions (Cont'd)

(3) Diversity Options

(M)

Diversity options are available where facilities exist. If appropriate facilities do not exist, Special Construction charges may apply. End-to-end diversity can be achieved by coupling Alternate Wire Center Diversity with Inter-Wire Center Diversity. HDVT and SCVS offer four diversity options:

(a) Local Channel Diversity (LCD)

LCD provides for a transmission path between a designated customer premises and the standard serving wire center (SWC) that is diverse from the normal/standard transmission path. LCD requires two HDVT or SCVS services purchased by, or on behalf of, the same customer. With this arrangement, one or more local distribution channels will be provisioned over the standard route, and one or more local distribution channels will be provisioned over the diverse route. LCD does not provide for full diversity; it only allows for diversity from the splice point closest to the customer's property line to the SWC. If a customer desires full diversity, arrangements must be made for constructing dual entrance facilities into the customer's premises, at the customer's expense. One LCD rate element applies for each channel termination.

(M)

Material on this page previously appeared on the 2nd Revised Page 2.1.

(B) Optional Features and Functions (Cont'd)(3) Diversity Options (Cont'd)(b) Inter-Wire Center Diversity (IWCD)

IWCD arrangements presume that each end of a HDVT or SCVS local distribution channel is served out of a different serving wire center (SWC). This arrangement provides a transmission path between the customer's designated SWC and the SWC at the distant end of the circuit, over a transmission path that is separate from the standard transmission path between the two wire centers. Interoffice mileage will be calculated between the intermediate WC along the circuit path of the diversely routed HDVT or SCVS service. IWCD requires two HDVT or SCVS services purchased by, or on behalf of, the same customer.

IWCD does not provide for full diversity; it only offers interoffice diversity. If a customer desires full diversity, Alternate Wire Center Diversity must be implemented along with IWCD. Additionally, arrangements must be made for constructing dual entrance facilities at the customer's premises, at the customer's expense.

(c) Alternate Wire Center Diversity (AWCD)

AWCD is for the local loop only. It provides a local channel transmission path for HDVT or SCVS service between the customer's designated premises and a wire center that is not the customer's standard serving wire center. The Telephone Company will choose the alternate wire center closest to the customer's designated premises that is capable of providing HDVT or SCVS service over the alternate route. AWCD does not require the purchase of two HDVT or SCVS services by, or on behalf of, the same customer, nor does it require the customer to have an existing HDVT or SCVS circuit operating over the standard route to the customer's standard serving wire center. With this arrangement, one or more local distribution channels will be provisioned over the alternate route. If a customer desires full diversity, arrangements must be made for constructing dual entrance facilities into the customer's premises, at the customer's expense. One AWCD rate element applies for each channel termination. (N)

(d) Equipment Only Diversity (EOD)

EOD allows for a HDVT or SCVS circuit to terminate on separate equipment from another HDVT or SCVS circuit. The diverse circuit will be provisioned on its own Equipment, i.e., separate laser, separate encoder/decoder, chassis, and separate power supply.

The customer must order at least two circuits and request that one of the circuits terminate on different equipment from the other circuit(s). A circuit subscribing to EOD will not be provisioned over a diverse route unless the customer orders one of the diversity options (local channel, alternate wire center, or inter-wire center). EOD may be selected for one or both terminating ends. One EOD rate element applies for each channel termination. (N)

7.2.10 Optical Carrier Network (OCN) Point-to-Point Service⁽¹⁾ (C)

(A) Basic Channel Description

(1) General

- (a) Optical Carrier Network (OCN) Point-to-Point channels provide high speed synchronous optical fiber-based full duplex data transmission capabilities. These services provide optical data transmission with the following characteristics:
 - (i) OC-3/OC-3c provides channels operating at the terminating bit rate of 155.52 Mbps;
 - (ii) OC-12/OC-12c provides channels operating at the terminating bit rate of 622.08 Mbps;
 - (iii) OC-48/OC-48c provides channels operating at the terminating bit rate of 2488.32 Mbps;
 - (iv) OC-192/OC-192c provides channels operating at the terminating bit rate of 9953.28 Mbps;
- (b) OC-3, OC-12, OC-48 and OC-192 channels may be used to connect:
 - (i) a customer designated premises to another customer designated premises, without the add/drop multiplexing capability;
 - (ii) a customer designated premises to a Telephone Company location where add/drop multiplexing and add/drop functions are performed;
 - (iii) a Dedicated SONET Ring Service node in a Telephone Company location to a customer designated premises or a Collocator's physical or virtual collocation--this serving arrangement is referred to as (SMOA) SONET Mapped Optical Arrangement or to a Telephone Company location where add/drop multiplexing and add/drop functions are performed, and this serving arrangement is referred to as (SMUX) SMOA with a MUX;
 - (iv) two Dedicated SONET Facility nodes in the same or different Telephone Company location--this serving arrangement is referred to as (DIN) Dedicated Interconnection Network.

Optical Transmission paths for OCN Point-to-Point Service differentiated by bit rate and the quality of transmission is as delineated by the Optical Interface definitions in the Technical Reference Publications cited in Section 7.2.

OC-3 Service, OC-12 Service and OC-48 Service may be connected by (1) using the appropriate OC-3, OC-12 or OC-48 add/drop multiplexer (mux) along with the add/drop function to an DS1 and/or DS3 at suitably equipped wire centers, or (2), by using the full bandwidth premises to premises.

⁽¹⁾ Effective on August 21, 2018, AT&T will no longer offer term plans longer than 36 months, including any renewals, extensions or conversions of existing term commitments. (N)
(N)

Where appropriate facilities are not immediately available, negotiated intervals may apply. The customer is responsible via the ordering process to identify what STS signal configuration is to be contained in each OC-3/OC-3c, OC-12/OC-12c and OC-48/OC-48c service connection and each STS-1, STS-3 and/or STS-12 payload content. This information is needed for routing and connection purposes in the network. OCN does not extend the SONET data communication channel overhead across the network interface to the customer's equipment.

Ethernet over SONET (EoS)

EoS allows the efficient transport of Ethernet frames using SONET. Ethernet Optical Add/Drop capability will be available in bandwidths up to 1 Gbps on an OC-N Point-to-Point. As SONET bandwidths will be present, the customer will be unable to transmit data beyond these preset SONET bandwidths. Only Single-Mode Fiber is available in the Central Office. The EoS line rates are based on the theoretical SONET payload line rates as per GR-253-CORE, Issue 4. These values are not representative of the true Ethernet transport capacity of the EoS circuit.

OCN Point-to-Point Service based on customer requirements can be configured in any of the following ways:

- (c) OC-3
 - (i) three STS-1 (Synchronous Transport Signals) channels which each contain:
 - (A) one DS3 that is STS-1 mapped; or
 - (B) up to 28 asynchronous DS1s that are VT-mapped; or
 - (C) an STS-1 channel without constraint to payload mapping when the STS-1 channel does not terminate via an add/drop function to DS1 or DS3 services within the Ameritech network; or
 - (D) 1 Gbps Ethernet STS-1 1-2v;
 - (ii) a single concatenated STS-3C channel.

-
- (d) OC-12
 - (i) twelve STS-1 channels which each contain:
 - (A) one DS3 that is STS-1 mapped; or
 - (B) up to 28 asynchronous DS1s that are VT-mapped; or
 - (C) an STS-1 channel without constraint to payload mapping when the STS-1 channel does not terminate via an add/drop function to DS1 or DS3 services within the Ameritech network; or
 - (D) 1 Gbps Ethernet STS-1 1-9v; or
 - (E) 1 Gbps Ethernet STS-3c 1-3v;
 - (ii) four concatenated STS-3C channels.
 - (iii) from one to three STS-3Cs channels mixed with from three to nine STS-1 channels subject to utilization of the total OC-12 capacity.
 - (iv) a single concatenated STS-12C channel.
 - (e) OC-48
 - (i) forty-eight STS-1 channels which each contain:
 - (A) one DS3 that is STS-1 mapped; or
 - (B) up to 28 asynchronous DS1s that are VT-mapped; or
 - (C) an STS-1 channel without constraint to payload mapping when the STS-1 channel does not terminate via an add/drop function to DS1 or DS3 services within the Ameritech network; or
 - (D) 1 Gbps Ethernet STS-1 1-21v; or
 - (E) 1 Gbps Ethernet STS-3c 1-7v;
 - (ii) sixteen concatenated STS-3C channels.
 - (iii) from one to fifteen concatenated STS-3C channels, mixed with from three to forty-five STS-1 channels subject to utilization of the total OC-48 capacity.
 - (iv) four concatenated STS-12Cs channels.
 - (v) from one to three concatenated STS-12C channels, mixed with from twelve to thirty-six STS-1 channels subject to utilization of the total OC-48 capacity.
 - (vi) from one to three concatenated STS-12C channels, mixed with from four to twelve concatenated STS-3C channels, also mixed with from three to thirty-three STS-1 channels subject to utilization of the total OC-48 capacity.
-

-
- (vii) from one to three concatenated STS-12C channels, mixed with from one to eleven concatenated STS-3C channels, also mixed with from three to thirty-three STS-1 channels, subject to utilization of the total OC-48 capacity.
- (f) OC-192
- (i) One hundred ninety two interleaved STS-1 Channels
 - (A) one DS3 that is STS-1 mapped; or
 - (B) up to 28 asynchronous DS1s that are VT-mapped; or
 - (C) an STS-1 channel without constraint to payload mapping when the STS-1 channel does not terminate via and Add/Drop Function to DS1 or DS3 services within the Ameritech network; or
 - (D) 1 Gbps Ethernet STS-1 1-21v; or
 - (E) 1 Gbps Ethernet STS-3c 1-7v;
 - (ii) Sixty-four interleaved concatenated STS-3 channels.
 - (iii) From one to sixty-three interleaved concatenated STS-3c channels, mixed with from three to one hundred and eighty nine STS-1 channels, subject to utilization of the total STS-192 capacity.
 - (iv) Sixteen interleaved concatenated STS-12c channels.
 - (v) From one to fifteen interleaved concatenated STS-12c channels mixed with from twelve to one hundred and eighty STS-1 channels, subject to utilization of the total STS-192 capacity.
 - (vi) From one to fifteen interleaved concatenated STS-12c channels, mixed with from four to sixty concatenated STS-3c channels subject to utilization of the total STS-192 capacity.
 - (vii) From one to fifteen interleaved concatenated STS-12c channels, mixed from one to fifty nine concatenated STS-3c channels, also mixed with from three to one hundred and seventy seven STS-1 channels, subject to utilization of the total STS-192 capacity.

-
- (viii) Four interleaved concatenated STS-48c channels.
 - (ix) From one to three interleaved concatenated STS-48c channels, mixed with from forty eight to one hundred and forty four STS-1 channels, subject to utilization of the total STS-192 capacity.
 - (x) From one to three interleaved concatenated STS-48c channels, mixed with from sixteen to forty eight STS-3c channels, subject to utilization of the total STS-192 capacity.
 - (xi) From one to three interleaved concatenated STS-48c channels, mixed with from four to twelve STS-12c channels, subject to utilization of the total STS-192 capacity.
 - (xii) From one to three interleaved concatenated STS-48c channels, mixed with from one to forty seven concatenated STS-3c channels, also mixed with from three to one hundred and forty one STS-1 channels, subject to utilization of the total STS-192 capacity.
 - (xiii) From one to three interleaved concatenated STS-48c channels, mixed with from one to eleven concatenated STS-12c channels, also mixed with from twelve to one hundred and thirty two STS-1 channels, subject to utilization of the total STS-192 capacity.
 - (xiv) From one to three interleaved concatenated STS-48 channels, mixed with from one to eleven concatenated STS-12c channels, also mixed with from four to forty four concatenated STS-3c channels, subject to utilization of the total STS-192 capacity.
 - (xv) From one to three interleaved concatenated STS-48 channels, mixed from one to eleven concatenated STS-12c channels, also mixed with from three to one hundred and twenty nine STS-1 channels, subject to utilization of the total STS-192 capacity.

(B) Channel Configuration

OCN Point-to-Point Channels consist of Local Distribution Channels (LDCs), interoffice transport and optional features and functions.

(1) OCN Point-to-Point Local Distribution Channels

The Local Distribution Channel rate category (same as Channel Termination) provides for the communications path between a customer designated premises and the serving wire center of that premise. LDC's are only offered without SBC provided and maintained terminal OLT equipment at the customer's designated premises and will hand-off basic 2-fiber or 4-fiber optic cables, depending upon the optional feature (as ordered). One LDC is applied per customer designated premises at which the channel is terminated even if collocation exists.

(D)

OCN Point-to-Point Local Distribution Channels provide optical interconnection between the Telephone Company Serving Wire Center (SWC) and the customer premises.

The following types of LDCs are available:

OC-3/OC-3c
OC-12/OC-12c
OC-48/OC-48c
OC-192/OC-192c

When OCN Point-to-Point Service is provided, the customer is responsible for providing the Optical Line Termination (OLT) at the customer's premises. The OLT supplied at the customer premises must be compatible with the OLT used by the Telephone Company in the Serving Wire Center. The Telephone Company will work cooperatively with the customer to select compatible OLTs which conform to the requirements set forth in Technical Reference Publication AM-TR-TMO-000101.

All LDCs comprising a channel must have the same terminating bit rate unless multiplexing is performed at a Telephone Company Hub location.

(2) Interoffice Transport

Interoffice Transport facilities comprised of Fixed and Per Mile rate elements, provide the transmission paths between Serving Wire Centers associated with two customer designated premises or between a Serving Wire Center associated with a customer premises and a Telephone Company Hub location. Four interoffice transport types are available. OC-3/OC-3c which supports bit rate of 155.52, Mbps OC-12/OC-12c at a bit rate of 622.08 Mbps, OC-48/OC-48c at a bit rate of 2488.32 and OC-192/OC-192c at a bit rate of 9953.28 Mbps. (T)

OC-3/OC-3c LDCs are interconnected to OC-3/OC-3c transport.

OC-12/OC-12c LDCs are interconnected to OC-12/OC-12c transport.

OC-48/OC-48c LDCs are interconnected to OC-48/OC-48c transport.

OC-192/OC-192c LDCs are interconnected to OC-192/OC-192c transport

In addition, interoffice transport can be connected between wire centers with Add/Drop multiplexing at a lower OC-N speed than the LDC, if the transport is between a lower speed Add/Drop Function and:

-another lower speed Add/Drop Function;

-another lower speed Local Distribution Channel;

-a lower speed Dedicated Ring Port;

All of the above terminations must be the same speed as the transport.

(3) Optional Features and Functions

The following optional features and functions are available:

Add/Drop Multiplexing;
Add/Drop Function;
OC-3, OC-12, OC-48 and OC-192 Cross-Connects;
1+1 Protection (OC-3/OC-3c, OC-12/OC-12c, OC-48/OC-48c and OC-192);
1+1 Protection with Cable Survivability (OC-3/OC-3c, OC-12/OC-12c, OC-48/OC-48c and OC-192);
1+1 Protection with Route Survivability (OC-3/OC-3c, OC-12/OC-12c, OC-48/OC-48c and OC-192);
1+1 Protection with Diversity;
1+1 with Site Survivability
1+1 Protection with Central Office Survivability*
1+1 Protection with Customer Premises Survivability*; and
Regenerators (OC-48 and OC-192).

(a) OC-3, OC-12, OC-48 and OC-192 Add/Drop Multiplexing.

Add/Drop multiplexing is an arrangement in a Telephone Company central office that allows an non-concatenated OC-3, OC-12, OC-48 or OC-192 channels operating at a terminating speed of 155.52 Mbps, 622.08 Mbps, 2488.32 Mbps or 9953.28 Mbps, respectively, to add/drop a lower speed channel by using this feature along with the add/drop function as set forth in Section 7.2.10(B)(3)(b). The mix of multiplexing signals cannot exceed the maximum bandwidth of the higher speed OCN circuit terminating on the Central Office multiplexer. (T)

*1+1 Protection with Central Office Survivability for OC-3 and OC-12 and/or Customer Premises Survivability for OC-12 and OC-48, subscribed to, on or after January 11, 2002, will no longer be available.

For example, OC-3 add/drop multiplexing at a Telephone Company wire center will provide the capability to support the full add/drop function capacity of OC-3 Service bandwidth with up to 3 DS3 add/drop functions or equivalently up to 3 groups of 28 DS1 add/drop functions.

At the time of ordering any of the following basic rate categories, the customer must provide configuration information for the entire multiplexing option at the time the order for service is placed. In addition, concatenated services OC-3, OC-12 or OC-48 cannot be ordered under the central office feature section as the Telephone Company cannot convert individual STS-1 signals to concatenated (non-channelized) channels.

OC-12 add/drop multiplexing at a Telephone Company wire center will provide the capability to support the full add/drop function capacity of OC-12 service bandwidth with up to 4 OC-3 add/drop functions or up to twelve DS3 add/drop functions or equivalent combinations of OC-3 and DS3 add/drop functions.

If asynchronous DS1 ports are required on a OC-12 OCN circuit, then the OC-3 add/drop multiplexing feature and associated DS1 add/drop function must be ordered in addition to the OC-12 add/drop multiplexing feature.

OC-48 add/drop multiplexing at a Telephone Company wire center will provide the capability to support one quarter of the add/drop function capacity of OC-48 service bandwidth. Up to four OC-48 add/drop multiplexing options may be provided with each supporting one OC-12 add/drop function, or up to 4 OC-3 add/drop functions or up to twelve DS3 add/drop functions or equivalent combination of OC-3 and DS3 add/drop functions. If DS1's are required for the OC-12 then the preceding guidelines established can be followed.

OC-192 add/drop multiplexing at a Telephone Company wire center will provide the capability to support full add/drop function capacity of OC-192 service bandwidth. Up to four OC-48 add/drop functions, or up to 16 OC-12 add/drop functions, or up to 64 OC-3 add/drop functions or equivalent combinations of OC-48, OC-12 and OC-3 add/drop functions are supported.

(b) Add/Drop Function

The OCN Point-to-Point Service is able to add or drop lower level signals as shown in the matrix following. The add/drop function is offered at a circuit level. For example, if a customer wants to drop one DS3 signal from an OC-12 service, they would pay one add/drop function charge for the DS3 and the initial OC-12 add/drop multiplexing charge.

An OCN Point-to-Point Service is only able to add/or drop the services that have been identified by payload content (mapping) within the bandwidth. DS1 mapped STS-1 signals are only able to connect to a DS1, and a DS3 mapped STS-1 signals are only able to connect to a DS3. If a change is required it may be accomplished by the customer's CPE or through the current asynchronous environment for multiplexing of DS3 and DS1 services stated in Section 7.2.9 of Tariff F.C.C. No. 2.

The options in Sections 7.2.10(B) (3) (a) and (b) cannot be used with OC-3, OC-12 or OC-48 Service configured by the customer to contain a single non-channelized (concatenated) STS-3C or STS-12C signal, respectively. (T)

Ethernet over SONET (EoS) is supported by an Add/Drop function. The quantities allowed will depend upon the VT or STS bandwidth assigned over the port.

ADD/DROP Function

	DS1	DS3	OC-3	OC-12	OC-48	1000 Base LX
OC-192	No	No	Yes	Yes	Yes	Yes
OC-48	No	Yes	Yes	Yes	N/A	Yes
OC-12	No	Yes	Yes	N/A	N/A	Yes
OC-3	Yes	Yes	N/A	N/A	N/A	Yes

(c) OC-3, OC-12, OC-48 and OC-192 Cross-Connect

An arrangement to cross-connect OC-3 Service, OC-12 Service, OC-48 or OC-192 Service to another service or to an add/drop function of the same speed at a wire center for the same or for a different customer on a per circuit basis. The customer must purchase service to the wire center from his designated premises. One charge applies per service cross-connected.

(d) 1+1 Protection

This option provides two identical fiber pairs that are placed in the same cable and follows the same route. If the working pair fails, traffic shifts to the protected fiber pair. This option does not protect against a fiber cable cut.

The protected OC-3/OC-3c Service, OC-12/OC-12c Service, OC-48/OC-48c Service and OC-192/OC-192c Services are offered with four fibers in the same cable, and the protection card is activated when this option is ordered. This will allow customers to order protection if their CPE can accommodate it.

(e) 1+1 Protection with Cable Survivability⁽¹⁾

With this option, the working fiber pairs and the protect fiber pairs are located in two separate cables within the same conduit. If the working fiber pair cable experiences damages or a fiber cut, traffic will switch to the protected fiber pair in a separate cable. These cables are located in the same conduit, if the conduit is cut, there is no protection.

This option will provide 1+1 protection and additional loop survivability with the working fiber pair and protect fiber pair placed in separate cables within the same conduit.

⁽¹⁾Not available for OCN service originating and terminating within a Telephone Company location.

(f) 1+1 Protection with Route Survivability ⁽¹⁾

This option will provide 1+1 protection and offer additional protection from fiber cable cuts by routing the working fiber pair via the primary route and the protected fiber pair via a physically diverse alternate route. The protected fiber will be charged on a distance sensitive basis, in addition to the protection optical charge and will be based on quarter route miles, from the customer premises to the serving wire center.

This is the only option that will also assure 100 percent availability of the service. Any service interruption will result in a credit equal to one month's bill for the circuit involved. If the interruption occurs on a Local Distribution Channel without this option, normal terms and conditions for out of service credits as stated in Part 2, Section 2 of this Guidebook, will apply. An interruption period will start when an inoperative service is reported to the Telephone Company and end when the service is operative. In any month, as a result of an interruption, the total credit per rate element of the interrupted service may not exceed 100 percent of the monthly charge for that particular rate element. All other terms and conditions for Credit Allowances as stated in Part 2, Section 2 of this Guidebook, will apply.

(T)
(T)

(T)

Prior to confirming an order for service, the Telephone Company will provide a proposed route diagram to the customer. The diagram will include the number of quarter route miles and method used to support the number needed to provide the alternate route. In order to avoid compromising Route Survivability information, the Telephone Company will provide this information only to the ordering customer.

Installation of the 1+1 protection with Route Survivability option will not begin until the customer has accepted the proposed routing by the Telephone Company.

⁽¹⁾ Not available for OCN service originating and terminating within a Telephone Company location.

(g) Diversity

This option will provide end-to-end diversity from A-Z for the second like service. It requires a charge for mileage on a "per Quarter Route Mile" basis, for each customer premises or Local Distribution Channel (LDC), only when both circuits terminate at the same customer premises. The standard OCN PTP service is provided without protection, but it is still an option with Diversity. 1+1 Protection is defined above and rates will apply as stated in Diversity Sections, 7.5.10 (A) (4) (i) - (OC-3), 7.5.10 (B) (4) (j) - (OC-12), 7.5.10 (C) (4) (j) - (OC-48), and 7.5.10 (D) (4) (h) - (OC-192). For the inter-office portion, the Diversity rate will cover any additional air-line mileage between serving wire centers. (T)

This is the only option that will assure 100% availability from end-to-end of the service. Any service interruption of both services at the same time will result in a credit of one month's bill for the second circuit. If the interruption occurs on a section of the service where commonality has been identified to the customer, normal terms and conditions for out of service credits, as stated in Part 2, Section 2 of this Guidebook, will apply. An interruption period will start when an inoperative service is reported to the Telephone Company, and end when the service is operative. In any month, as a result of an interruption, the total credit per rate element of the interrupted service may not exceed 100 percent of the monthly charge for that particular rate element. (T)

All other terms and conditions for Credit Allowances, as stated in Part 2, Section 2 of this Guidebook, will apply. (T)

Prior to confirming an order for service, the Telephone Company will provide a proposed route diagram to the customer. The diagram will include the number of quarter route miles and method used to support the number needed to provide the alternate route. In order to avoid compromising Route Survivability information, the Telephone Company will provide this information only to the ordering customer. (T)

Installation of the Diversity option will not begin until the customer has accepted the proposed routing by the Telephone Company. (T)

(h) 1+1 Protection with Site Survivability

(1) 1+1 Protection with Central Office Survivability
for OC-3 and OC-12*

This option will provide 1+1 protection and offer additional protection from Serving Wire Center (SWC) failure for services not terminating at the SWC by routing the working fiber pair via the primary route to the customer's SWC and the protect fiber pair to an alternate wire center chosen by the Telephone Company. The protect fiber will be charged on a distance sensitive basis, based on quarter route miles, from the customer premises to the alternate wire center. Channel Mileage and Channel Mileage Terminations for the appropriate OC-3 or OC-12 service ordered will be charged between the SWC and the alternate wire center using the V&H coordinates method as stated in National Exchange Carrier Association, Inc. Tariff F.C.C. No. 4.

(T)

This option will also assure 100 percent availability of the service. Any service interruption will result in a credit equal to one month's bill for the circuit involved. If the interruption occurs on a Local Distribution Channel without this option, normal terms and conditions for out of service credits as stated in Part 2, Section 2 of this Guidebook, will apply. An interruption period will start when an inoperative service is reported to the Telephone Company and end when the service is operative. In any month, as a result of an interruption, the total credit per rate element of the interrupted service may not exceed 100 percent of the monthly charge for that particular rate element. All other terms and conditions for Credit Allowances as stated in Part 2, Section 2 of this Guidebook, will apply.

*1+1 Protection with Central Office Survivability for OC-3 and OC-12
subscribed to, on or after January 11, 2002, will no longer be available.

Prior to confirming an order for service, the Telephone Company will provide a proposed diagram to the customer. The diagram will include the number of quarter route miles and method used to support the number needed to provide the route to the alternate wire center. In order to avoid compromising Central Office Survivability information, the Telephone Company will provide this information only to the ordering customer.

Installation of the 1+1 protection with Central Office Survivability option will not begin until the customer has accepted the proposed routing by the Telephone Company.

If the customer wants to use this optional feature as a point-to-point extension with OC-12 or OC-48 Dedicated Ring Service, then both the customer's Serving Wire Center and alternate wire center must have Nodes located on the ring. The Telephone Company will work cooperatively with the customer to determine the appropriate alternate wire center to be used for the Dedicated Ring situation. Channel Mileage and Channel Mileage Termination will not apply to this option when used with a ring extension.

(2) 1+1 Protection with Customer Premises Survivability (CPS) for OC-12 and OC-48*

1+1 Protection with Customer Premises Survivability (CPS) offers traditional 1+1 protection with additional protection from customer premises failure. The CPS option provides diverse routing for the OC-N service protection path between the primary customer premises serving wire center (PSWC) and an alternate customer premises. This option will allow originating and terminating OC-N traffic to be routed to the PSWC via an alternate customer's premises Serving Wire Center (ASWC) in case of a failure.

*1+1 Protection with Central Office Survivability for OC-3 and OC-12 and/or Customer Premises Survivability for OC-12 and OC-48 subscribed to, on or after January 11, 2002, will no longer be available.

Using this option, the customer and the Telephone Company jointly select a single wire center from which add/drop multiplexing is allowed. This wire center may be the PSWC, the ASWC or another Telephone Company wire center equipped with add/drop multiplexing.

OC-N Channel Mileage (CM) and Channel Mileage Termination (CMT) rate elements are not available with this option.

CPS mileage applies between the PSWC, ASWC and the add/drop multiplexing wire center (when applicable) and is assessed on a per air mile basis. Calculation of air mileage is described in Part 2, Section 7 of this Guidebook. (T)

The CPS Termination charge applies at the PSWC and the ASWC. If an add/drop multiplexer location different from either the PSWC or ASWC is utilized, two additional CPS Termination Charges apply at that location.

CPS OC-N Regenerator provides for signal regeneration on a per OC-N regenerator basis (if required) when the actual protection path exceeds design limits (typically 25 to 30 air miles).

CPS Extension represents the facility utilized between the alternate customer premises and the alternate serving wire center. The CPS Extension, while architecturally similar to a Local Distribution Channel, differs in that the facilities are dedicated to the protection path for this customer application. The cost of this rate element is independent of the speed of the service unlike the Local Distribution Channel (LDC) which changes along with the service channel required for the OC-N service.

*1+1 Protection with Customer Premises Survivability for OC-12 and OC-48 subscribed to, on or after January 11, 2002, will no longer be available.

(2) 1+1 Protection with Customer Premises
Survivability (CPS) for Ameritech OC-12 and
Ameritech OC-48* (Cont'd)

Both customer and Telephone Company equipment must be configured for path switching/ring operation per Ameritech Technical Reference AM-TR-NIS-000111 for this option.

Rate elements for Customer Premises Survivability (CPS) include;

- CPS Mileage (measured in air miles - one mile minimum)
- CPS Termination (per wire center - as required)
- CPS Regenerator OC-N (as required)
- CPS Extension (from the ASWC to the alternate customer premises)

If existing facilities do not exist, Special Construction may apply.

(i) Point-to-Point OC-48 and OC-192 Regenerator

Regenerators provide essential detection and retransmission of SONET Optical 2488.32 Mbps or 9953.28 Mbps signals between customer premises. Regenerators will only be provided as required by the Telephone Company when actual fiber facility distances between customer designated premises and/or central office locations exceed design limits (typically 25 to 30 miles). Regenerators will be located exclusively in Telephone Company central offices.

*1+1 Protection with Customer Premises Survivability for OC-12 and OC-48 subscribed to, on or after January 11, 2002, will no longer be available.

The following diagrams provide an example of (d), (e) and (f) above:

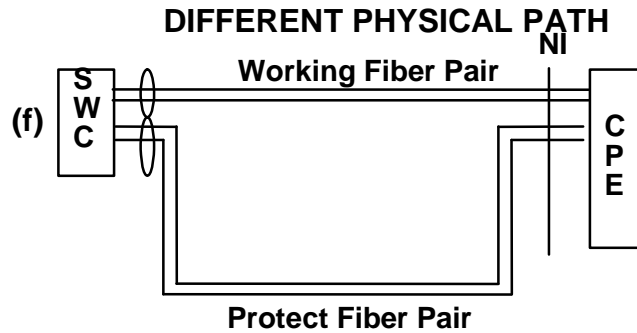
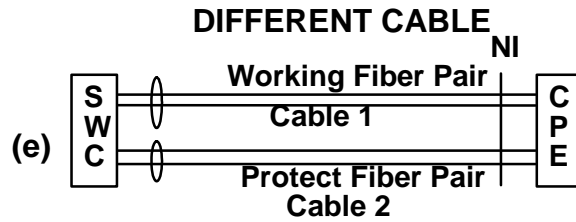
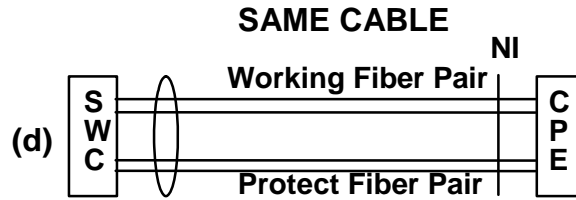

The following diagram provides an example of (h) (1) above:

1 + 1 Protection with Central Office Survivability *

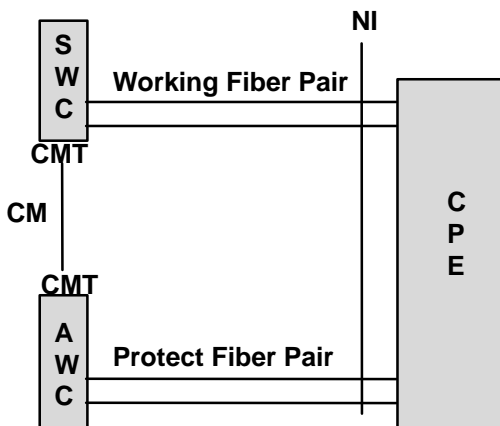

- *CM = Channel Mileage
- *CMT = Channel Mileage Terminations
- AWT = Alternate Wire Center

*1+1 Protection with Central Office Survivability for OC-3 and OC-12 subscribed to, on or after January 11, 2002, will no longer be available.

The following diagram provides an example of (h) (2) above:

1 + 1 PROTECTION WITH CUSTOMER PREMISES SURVIVABILITY*

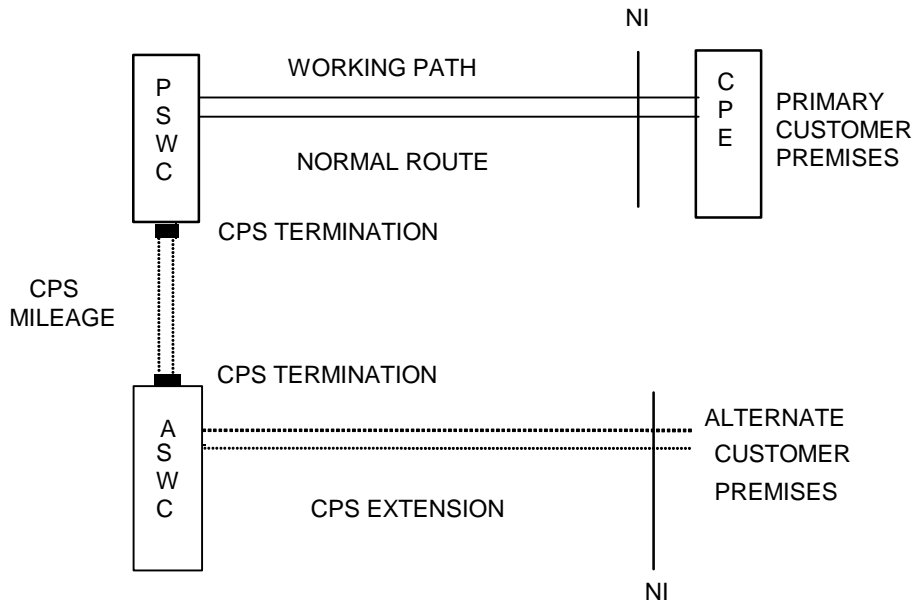

CPS = Customer Premises Survivability
 ASWC = Alternate Serving Wire Center
 PSWC = Primary Serving Wire Center
 - - - = Protection Path

*1+1 Protection with Customer Premises Survivability for OC-12 and OC-48 subscribed to, on or after January 11, 2002, will no longer be available.

The following diagram provides an example of (g) above:

OC-N PTP Survivability with Diversity (Two Circuits Diverse E-E, same locations)

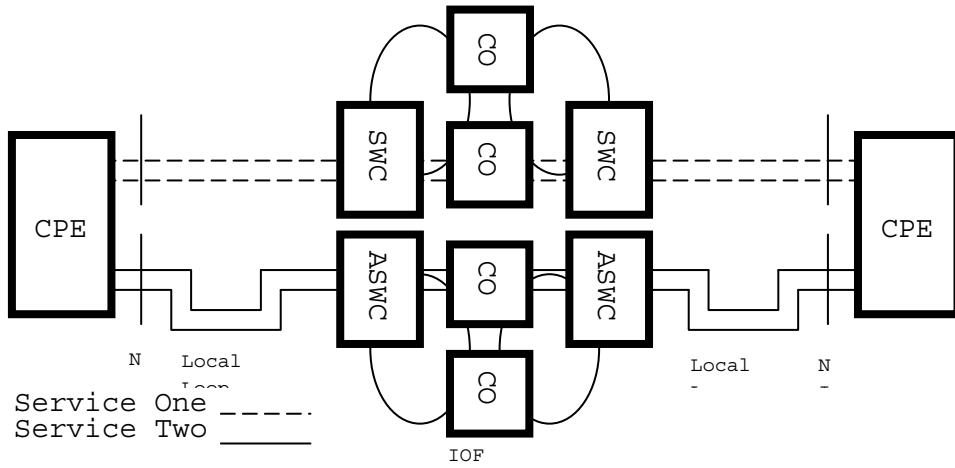

(I) Shared Network Arrangement⁽¹⁾

(i) A Shared Network Arrangement is a service offering that enables a customer ("Service User") to connect subtending services to the multiplexed OCN Point-to-Point service of another customer (the "Host Subscriber"), with the Telephone Company maintaining separate billing for each. Each customer will be billed for those rate elements associated with their own portion of the service configuration. Under no circumstances will the rates or charges for individual rate elements be split. This offering is limited to service configurations where a Service User obtains either subtending DS3 or DS1 from a Host's multiplexed OC-3 service or an OC-3 service from a Host's multiplexed OC-12 service or an OC-12 service from a Hosts' multiplexed OC-48 service or an OC-48 service from a Hosts' multiplexed OC-192 Service.

(ii) Under the Shared Network Arrangement, the Telephone Company may share record information with the Host subscriber pertaining to the services of other users of the shared network. Such disclosure will be under the sole discretion of the Telephone Company and is necessary to perform billing reconciliation and/or other functions required in connection with maintaining account records.

(iii) Part 2, Section 7 this Guidebook contains rate conditions specific to Shared Network Arrangements. (T)

(4) Technical Specifications Packages

The technical specifications for OC-3/OC-3c, OC-12/OC-12c and OC-48/OC-48c and OC-192 are described in Technical References, AM-TR-NIS-000111 and AM-TR-TMO-000101.

(1) Effective 05/26/06, this condition is limited to existing customers. For new customers purchasing Shared Network Arrangement, terms and conditions set forth in Part 2, Section 5 of this Guidebook, will apply. (T)

(5) Network Channel Interfaces

The network channel interfaces define the bit rates that are available for OCN Point-to-Point Services operating at speeds of 155.52 Mbps, 622.08 Mbps, 2488.32 Mbps, and 9953.28 Mbps. Network Channel interfaces and codes are described in Part 2, Section 7 of this Guidebook.

(C) Monthly Extension Rates⁽²⁾

At the expiration of the TPP term and if the customer wishes to continue OC-3/OC-3c, OC-12/OC-12c, OC-48/OC-48c, OC-192/OC-192c, the customer may select a new TPP⁽³⁾ at the prevailing TPP rate. (C)

If a customer does not wish to renew the TPP at the expiration of the term, the Monthly Extension Rates will apply until the customer cancels or renews the service with a new TPP term. Monthly Extension Rates are not available as an individual TPP and are to be used as a default applied at the end of a regular 1 year (12 month), 3 year (36 month), and 5 year (60 month)⁽³⁾ TPP. (C)

(D) Nonrecurring Charges*

Nonrecurring charges are one-time charges that apply for specific work activity (i.e., installation of new services and rearrangements of installed services), as described in Part 2, Section 7 of this Guidebook.

(E) Minimum Periods

The Minimum Period for the OCN Point-to-Point Service is one year for all customers including one, three and five year⁽³⁾ TPP customers.⁽¹⁾ The Minimum OC-192 OCN Point-to-Point Service is three years. In the event OCN Point-to-Point Service is terminated prior to completion of the minimum period, termination liabilities as described in Section 7.2.10(G) will apply. (C)

*For Services ordered under MVP, refer to Section 19.3(E) (5) of Tariff F.C.C. No. 2.

⁽¹⁾ As of November 27, 2004, the One Year Minimum Period for OC-192 OCN Point-to-Point Service will no longer be available to new customers. There will be no change to existing customers.

⁽²⁾ All term plans for OCN Point-to-Point Service which are established or renewed after November 9, 2013, for term lengths which are scheduled to expire at any time after December 31, 2017, will instead expire on December 31, 2017. All such services existing on or after December 31, 2017, will be provided on a month-to-month basis at the applicable, then current month-to-month rates. Notwithstanding anything to the contrary in the previous two sentences, this footnote does not apply to any term plans established or renewed after January 22, 2016.

⁽³⁾ Effective on August 21, 2018, AT&T will no longer offer term plans longer than 36 months, including any renewals, extensions or conversions of existing term commitments. (N)
(N)
(N)

(F) Term Pricing Plans (TPP) ⁽¹⁾ ⁽²⁾ (C)

(1) General Description

Term Pricing Plans (TPP) are available on Local Distribution Channels, Interoffice Transport and Add/Drop Multiplexing rate elements. The TPP stabilizes rates for OCN Point-to-Point Service for the specified period of time. The following TPPs are available:

- One Year (12 month) TPP,
- Three Year (36 Month) TPP, or
- Five-Year (60-Month) TPP⁽²⁾. (C)

(2) Modifications

When additional like-speed OCN Point-to-Point Service circuits are purchased, the customer may include the additional circuits in an existing TPP if:

- The customer renegotiates their TPP for a period of time equal to or greater than the time remaining on the existing TPP;
- The circuits are the same speed; and
- The circuits are located between the same customer designated premises.

(3) Renewals

At the end of a TPP period, the customer must select one of the following options within one month prior to the expiration date:

- a. Renew the service for a one, three or five year⁽²⁾ TPP as provided in this Guidebook; (C)
- b. Elect to disconnect the service upon expiration of the billing period; or
- c. Continue the service on a monthly basis at the current monthly extension rates.

All services under an existing TPP that are not renewed within the period stated above will revert to Option (3)(c) above and will be billed at the current monthly extension rates.

⁽¹⁾ All term plans for OCN Point-to-Point Service which are established or renewed after November 9, 2013, for term lengths which are scheduled to expire at any time after December 31, 2017, will instead expire on December 31, 2017. All such services existing on or after December 31, 2017, will be provided on a month-to-month basis at the applicable, then current month-to-month rates. Notwithstanding anything to the contrary in the previous two sentences, this footnote does not apply to any term plans established or renewed after January 22, 2016.

⁽²⁾ Effective on August 21, 2018, AT&T will no longer offer term plans longer than 36 months, including any renewals, extensions or conversions of existing term commitments. (N)
(N)
(N)

(4) Conversions

If there is at least one month remaining on an existing 1 or 3 year OCN Point-to-Point TPP, the customer may convert the service to a higher term OCN Point-to-Point TPP without termination liability and, at the time of the access order to convert, retain the service for the period remaining on the higher term OCN Point-to-Point TPP. No retroactive OCN Point-to-Point TPP discounts will apply prior to the order date.

For example; a customer with an existing 3 Year OCN Point-to-Point TPP with 11 months remaining elects to convert to a 5 Year⁽¹⁾ OCN Point-to-Point TPP. At the time of the order, the customer will begin paying the 5 year⁽¹⁾ TPP rate for the remaining period of 2 years and 11 months (35 months) on the new TPP. (C)

(5) Transitioning from Other Special Access Services to OCN Point-to-Point

The customer may, at any time, move other Telephone Company Special Access Services that have not been grandfathered, to an OCN Point-to-Point service. Charges for the transition will be the nonrecurring charges for the installation of the new OCN Point-to-Point rate elements as listed in Section 7.5.10. No other charges, such as Service Facility Moves will be applicable to such transitions. The relevant Telephone Company sections for the services, if applicable for the Special Access Services being transitioned from, will govern termination charges in question.

In the event that the current Point-to-Point Special Access service is no longer available to the customer and their existing term payment plan has not been completed or expired, the customer may choose to convert their TPP using the OCN Point-to-Point service as described in Section 7.2.10(N). If the customer's TPP expires and the customer does not choose to renew their TPP for any of the Telephone Company Access Services including OCN Point-to-Point, or if the customer fails to notify the Telephone Company of their plans to renew their TPP upon expiration of the current TPP, all TPPs will become subject to Monthly Extension Rates as set forth in Section 7.2.10(C). Upon notification by the customer that renewal of the TPP or the cancellation of service is needed, the Telephone Company will remove the monthly extension rate and normal TPP terms and conditions will apply or not apply in the case of cancellation of service.

⁽¹⁾ Effective on August 21, 2018, AT&T will no longer offer term plans longer than 36 months, including any renewals, extensions or conversions of existing term commitments. (N)

(G) Termination Liability

Customer requesting termination of service prior to the expiration date of the OCN Point-to-Point TPP will be liable for a termination charge. The termination charge for all TPP terms⁽¹⁾ with an Optical Interface will be calculated as follows:

Billing Period	Termination Percentage	
1, 3, or 5 years ⁽²⁾	50%	(C)

The termination liability is calculated as follows:

(Monthly recurring rate) X (Months remaining X (Termination percentage) in billing)

Example:

An OCN Point-to-Point customer with a \$20,000 monthly rate terminates service after 2 years with 1 year (12 months) remaining in a 3 year TPP. The termination liability would be calculated as:

$$\$20,000 \times 12 \times .50 = \$120,000 \text{ Termination Liability}$$

A termination charge will not apply under the following conditions and circumstances:

1. Moves as set forth under "Moves" without decreasing number of OC-N PTP circuits
2. Modifications of services as described in the Guidebook
3. Conversions to other special access service if
 - a. service is same or higher
 - b. billing period same or greater
 - c. billing period revenue for the special access service is greater than or equal to the OC-N PTP billing period revenue.

(H) Moves

Moves involve a change in the physical location of one of the following:

- Service rearrangement;
- Point of Termination at the customer's premises; or
- Customer's premises.

Move charges are dependent upon the type of move requested by the customer.

⁽¹⁾All term plans for OCN Point-to-Point Service which are established or renewed after November 9, 2013, for term lengths which are scheduled to expire at any time after December 31, 2017, will instead expire on December 31, 2017. All such services existing on or after December 31, 2017, will be provided on a month-to-month basis at the applicable, then current month-to-month rates. Notwithstanding anything to the contrary in the previous two sentences, this footnote does not apply to any term plans established or renewed after January 22, 2016.

⁽²⁾Effective on August 21, 2018, AT&T will no longer offer term plans longer than 36 months, including any renewals, extensions or conversions of existing term commitments.

(N)
(N)

(1) Service Rearrangement

Service rearrangements are changes to existing (installed) services which do not result in either a change in the minimum period requirements, as set forth in Part 2, Section 5, or a change in the physical location of the point of termination at a customer or customer's end user premises, as described in Part 2, Section 7 of this Guidebook. (T) (D)

(2) Moves Within the Same Building

When the move is to a new location within the same building, the Administrative Charge and Customer Connection Charge for the service termination affected will apply. There will be no change in the minimum period requirements, as described in Part 2, Section 7 of this Guidebook.

(3) Moves To a Different Building

Moves to a different building will be treated as a discontinuance and start of service and all associated nonrecurring charges will apply. New minimum period requirements will be established for the new services. The customer will also remain responsible for satisfying all outstanding minimum period charges for the discontinued service, as described in Part 2, Section 7 of this Guidebook.

(I) Mileage Measurement

The mileage is calculated on the airline distance between the locations involved, i.e., the serving wire centers associated with two customer designated premises, the serving wire center associated with a customer designated premises and an international boundary point, a serving wire center associated with a customer designated premises and a Telephone Company Hub, a serving wire center associated with a customer designated premises and a WATS Serving Office as described in Part 2, Section 7 of this Guidebook.

(J) Modification of Access Service

The customer may request a modification of its Access Order at anytime prior to notification by the Telephone Company that service is available for the customer's use. The Telephone Company will make every effort to accommodate a requested modification when it is able to do so with the normal work force assigned to complete such an order within normal business hours. If the modification cannot be made with the normal work force during normal business hours, the Telephone Company will notify the customer.

If the customer still desires the Access Order modification, the Telephone Company will schedule a new service date. All charges for Access Order modifications will apply on a per occurrence basis as described in Part 2, Section 5 of this Guidebook.

(T)
(T)

(K) Shared Use

Shared use occurs when Special Access Service and Switched Access Service are provided over the same Wideband Analog* or DS1 or DS3 facilities or SONET based services through a common interface. The facility will be ordered, provided and rated as Special Access Service (e.g., Channel Termination, DS3 Service Packages, DS3 Service Channels, Channel Mileage Terminations and Channel Mileage, as appropriate, and Multiplexing).

The nonrecurring charge that applies when the Shared Use Facility is installed will be the nonrecurring charge associated with the installation of the appropriate Special Access Wideband Analog or DS1 or DS3 facility or SONET based service. Individual service (i.e., Switched or Special Access) nonrecurring charges will not apply to the individual channels of the Shared Use Facility. Rating as Special Access will continue until such time as the customer chooses to use a portion of the available capacity for providing Switched Access Transport Service from the office where multiplexing occurs to either an end office or an access tandem.

(L) Jointly Provided Service

Jointly Provided Service is also referred to as "meet-point-billing" arrangements. The service consists of one end of an OCN Point-to-Point circuit located in one exchange telephone company operating territory and the other end of service located in another exchange telephone company operating territory.

(M) Ordering Options and Conditions

The ordering options and conditions section sets forth the conditions and order related charges for Access Orders for Switched and Special Access Services and Specialized Services and Arrangements and Planned Facilities Orders for Switched Access Services as described in Part 2, Section 5 of this Guidebook.

(T)
(T)

*Wideband Analog Service is limited to circuits in place as of August 11, 1988.

(N) Upgrade to OCN Point-to-Point from lower speeds

Customers with one, three, or five year⁽¹⁾ OCN Point-to-Point TPPs may at any time upgrade OCN Point-to-Point service (e.g., OC-48 to OC-192) without incurring the Termination Liability charge, providing the following criteria are met: (C)

- The customer subscribes to a Term Pricing Plan period that is equal to, or greater than 12 months;
- The expiration date for the new Term Pricing Plan period is beyond the end of the original Term Pricing Plan period;
- No lapse in service occurs;
- 100% of any waived or unamortized nonrecurring charges will apply, when applicable;
- The monthly rates for the new service(s) will be those rates in effect at the time the new service(s) is/are installed;
- The new service is provided between the same customer locations and with the same customer of record as the disconnected service;
- The billed monthly recurring revenue for the new service is equal to or greater than the billed monthly recurring revenue remaining in the service being converted.

⁽¹⁾ Effective on August 21, 2018, AT&T will no longer offer term plans longer than 36 months, including any renewals, extensions or conversions of existing term commitments.

(N)
(N)

7.2.11 OC-3, OC-12, OC-48 and OC-192 Dedicated Ring

(A) Basic Service Description

(1) General

OC-3, OC-12, OC-48 and OC-192 Dedicated Ring provides the customer with a dedicated custom network. The network is in a ring architecture, including sub-rings or Arc sub-rings provisioned on Next Generation SONET equipment, designed to provide increased reliability and functionality connecting multiple customer designated locations and specified Telephone Company Central Offices (COs) via self healing network designs. Dedicated SONET Rings OC-3, OC-12, OC-48 and OC-192 are available via Self-Healing Uni-Directional Path Switched Rings (UPSR); additionally, OC-48 and OC-192 are available via Self-Healing Bi-Directional Line Switched Rings (BLSR). A sub-ring is a lower speed ring made up of two or more sub-ring Nodes operating off the higher speed main ring. An Arc sub-ring is a lower speed ring made up of one or more Arc sub-ring nodes operating off the higher speed main ring. Dedicated Ring will provide 50 millisecond protection switching after fault detection to assure 100 percent availability of the services on the ring. Dedicated Ring is provided where appropriate SONET facilities are available. Where facilities are not available, Special Construction may apply.

Dedicated Ring is an alternative to OC-3/3c, OC-12/12c, OC-48/48c service between multiple customer locations. Rate elements include nodes, ports, mileage between nodes, regenerators, Optical to Electrical DS1 add/drop capability and Optical OC-48 add/drop capability. Rates are specified in Section 7.5.11.

(T)

Existing customers with point-to-point OC-3/3c, OC-12/12c and OC-48/48c may upgrade to Dedicated Ring without termination liability.

A service interruption will result in a credit equal to one month's bill for the individual port-to-port connection involved. An interruption of service will start when an inoperative service is reported to the Telephone Company and end when the service is operative. In any month, as a result of an interruption, the total credit per rate element of the interrupted service may not exceed 100 percent of the monthly charge for that particular rate element.

Customers may choose to accept a ring without diversity (i.e., no dual entrance), or prior to the cable diversity being available. In this situation (i.e., temporary or permanent unprotected Dedicated Ring Service), effective for new customers after (12/27/03), the customer may accept the ring without diversity. Credits for the unprotected portion of the ring will not apply until diversity is implemented on the ring.

(B) Dedicated Ring Configuration

(1) Nodes

The ring will provide connectivity to multiple customer designated locations (nodes). However, a ring must have a minimum of two nodes, excluding sub-ring nodes. At least one node must be a Telephone Company CO node. A maximum of 16 nodes including regenerators will be allowed per ring.

The Telephone Company reserves the right to determine the order of the nodes on the ring.

When a customer premises node is located in the same building as a CO node, diversity between the two nodes may not be available.

If a customer collocates two customer premises nodes of the same speed, on the same dedicated ring, on the same premises, the additional node will be billed as shown in Section 7.5.11. This option does not provide diversity between these two collocated nodes and the rest of the ring. (T)

If a customer has one or more additional OC-48 Dedicated Rings within a LATA, the Customer Premises Node, Central Office Node and the OC-48 Add/Drop Capability rate elements utilized on the additional OC-48 Dedicated Ring(s) and co-located with like primary OC-48 Dedicated Ring rate elements as described below will be billed as "Plus" ⁽¹⁾ as shown in Section 7.5.11. All existing requirements associated with Ameritech Dedicated Ring Service apply to additional rings. The eligibility requirements for the "Plus" ⁽¹⁾ rates are as follows: (T)

The primary dedicated ring is defined as the dedicated ring with the earliest installation date. If the primary dedicated ring is terminated by the customer and the customer still has two or more dedicated rings, the remaining dedicated ring with the earliest installation date will be designated as the new primary dedicated ring. If there are any additional dedicated rings, the nodes and add/drop capability that are common with the new primary dedicated ring will be billed as "Plus" ⁽¹⁾ nodes and "Plus" ⁽¹⁾ add/drop capability.

(1) Effective 03/18/06, the OC-48 "Plus" feature will no longer be available to new customers. There will be no change to existing customers.

If the primary OC-48 Dedicated Ring has either two or three nodes, then at least two nodes (excluding sub-ring or Arc sub-ring nodes) with separate addresses must be common between the primary OC-48 Dedicated Ring and the additional OC-48 Dedicated Ring(s). At least one of the common nodes must be a central office node.

If the primary OC-48 Dedicated Ring has four or more nodes, then at least three nodes (excluding sub-ring or Arc sub-ring nodes) with separate addresses must be common between the primary OC-48 Dedicated Ring and the additional OC-48 Dedicated Ring(s). At least one of the common nodes must be a central office node.

The customer will be billed time and material for any additional charges incurred by the Telephone Company in locating Company equipment at the customer premises.

Moves of Dedicated Ring nodes requested by the customer will be billed time and material for charges incurred. No change in the billing period is required. Termination Liability charges will not apply to moves of Dedicated Ring nodes. If an additional location, monthly node is placed to facilitate migration of services to the new node location, monthly node charges will apply to both the additional node and the node being moved during the period for service transition.

(a) Direct Drop Node⁽¹⁾

An optional Direct Drop Node (DDN) is available on an OC-12 dedicated ring. This Node has direct add/drop capability not to exceed 3 DS3s or its equivalent.

The remaining bandwidth of the OC-12 ring continues on through the Node to another drop point on the ring. Use of the Direct Drop Node allows customers to drop DS1s directly from the Node without the need for the Optical to Electrical DS1 Add/Drop Capability option.

OC-12 nodes and OC-12 DDNs may be used together in making up an OC-12 dedicated ring. A DS1 that enters the ring via a port on a Direct Drop Node must also exit via a port on another Direct Drop Node (DDN on - DDN off). A DS3 that enters the ring via a port on a Direct Drop Node may exit via a port on either a Direct Drop Node or OC-12 node. Direct Drop Node is not available in a two-node ring configuration.

(1) Effective 03/18/06, the Direct Drop Node feature will no longer be available to new customers. There will be no change to existing customers.

(b) Sub-Ring Node

A sub-ring node is a lower speed optical extension off a main ring. It traverses one or more main ring nodes via the use of OC-N port connections on and off the main ring. The primary use of sub-ring nodes is to provide the ability to fully utilize the bandwidth around the ring when the customer requires DS1/VT1.5 circuit paths.

An optional sub-ring node is available at OC-3, OC-12 and OC-48 speeds from an OC-192 main ring. A sub-ring node may only connect to the main ring at the same or an adjacent main ring node. A sub-ring node may not connect directly to another sub-ring node.⁽¹⁾

Any service that enters the main ring via a port on a sub-ring node must also exit via a port on another sub-ring node (sub-ring on - sub-ring off).⁽¹⁾ Cascading sub-rings are not allowed off a main ring. Service circuits may not be established between sub-ring nodes connecting to the same main ring node or between a sub-ring node and a port on the same main ring node to which it connects.

Each sub-ring must be implemented as an OC-m on an OC-n ring with full complement of STS-1s, 3 or 12 depending on the bandwidth of the sub-ring, appearing together at all associated sub-ring nodes on a given sub-ring.

OC-3 sub-rings and OC-12 DDNs may not be combined on an OC-12 main ring. OC-12 sub-rings and OC-12 DDNs may be combined on a sub-ring connected to an OC-48 main ring.

Two OC-n ports and associated node charges apply for each sub-ring node connected to the main ring, as well as applicable mileage for the sub-ring applies.

A sub-ring node which is co-located with a main ring node at the customers premises (for the same dedicated ring) will be billed as an "Additional Node" per Section 7.5.11(A) (T) following.

A sub-ring is not available with a two-node main ring configuration.

A sub-ring node is only available in the Uni-Directional Path Switched Ring (UPSR) mode.

⁽¹⁾ This restriction does not apply for Next Generation SONET equipment.

(c) Arc Sub-Ring Node

ARC sub-ring nodes are only available on Next Generation SONET equipment with service installed after November 2, 2007. An Arc sub-ring node is a lower speed optical extension off a main ring. It connects to one main ring node via the use of OC-N port connections from and to a main ring. The primary use of Arc sub-ring nodes is to add other locations to the ring that will utilize minimal amounts of bandwidth from the main ring.

Arc sub-rings are only available off of UPSR main rings. Arc sub-rings are only available where facilities and/or operating conditions permit, as determined by the Telephone Company.

An optical Arc sub-ring node is available at OC-3, OC-12 and OC-48 speeds from an OC-192 main ring, OC-3 and OC-12 speeds from an OC-48 main ring, and OC-3 speed from an OC-12 main ring. An Arc sub-ring node may connect to the main ring at any main ring node.

Cascading Arc sub-rings are not allowed off a main ring. Services entering an Arc sub-ring node cannot drop from the directly connecting main ring node (hairpinning).

More than one Arc sub-ring may be added to a main ring. Each Arc sub-ring must be implemented as an OC-M on an OC-N ring with a full compliment of STS-1s, 3s or 12s, depending on the bandwidth of the Arc sub-ring, appearing together at all associated Arc sub-ring nodes on a given Arc sub-ring.

Two OC-N ports apply for each Arc sub-ring node connected to the main ring. A node charge applies for each Arc sub-ring location. Mileage charges are applicable when the sub-ring is in a different location than the main ring.

An Arc sub-ring node which is collocated in the same room with a main ring node at the customer's premises (for the same dedicated ring) will be billed as an "Additional Node."

Arc sub-rings do not reduce the bandwidth capacity of the main ring. As services are added to the main or sub-ring, only the bandwidth capacity of the service is reduced.

Arc sub-rings can be provisioned in two basic configurations:

1. Single-node, single-homed ARC
2. Multi-node, single-homed ARC

Circuit traffic can be added/dropped from an Arc sub-ring node to another Arc sub-ring node within the same Arc (known as intra-ARC), or between ARCs (known as inter-ARC). Intra-ARC circuits can only be provisioned as unprotected due to technical limitations. Circuit traffic can also originate on an Arc sub-ring node and route across and drop from a main ring node, but only when UPSR protection schemes are used.

(d) Re-Map Node⁽²⁾

A Re-Map node is a ring node that is pre-equipped and dedicated to customer traffic that is re-mapped/re-routed to it by Ameritech upon notification by the customer of a service outage at another customer premises node on the same dedicated ring. Re-Map is designed as a temporary service for disaster recovery purposes only. No "normal" customer traffic will be added/dropped at the Re-Map node unless the Re-Map service is activated.

(e) Flex-Ring

Flex-Ring feature provides double the standard bandwidth levels for the Dedicated Ring product. The customer has the ability to double their bandwidth without ordering the next higher ring service.

(1) Double-Rings

Double-Rings will provide the ability to place two rings on the same DSRS equipment. Nodes of the second ring must be the same as the first ring. The second OC-12 and OC-48 ring is available and will require a new TPP upon the upgrade. All nodes on the ring will be at the same level. The additional higher speed optics may contribute to slot exhaustion on the main node. The standard features and components (mileage, ports, etc.) are available as described in Section 7.2.11 (B). The second ring will require another pair of fibers so mileage will apply to both rings. There will only be two rings available on a single SONET ring equipment. The second ring's line rate will be the same as the first ring.

Flex-Ring is not available with OC-192.

(2) Add/Drop Capability

(a) OC-48 Add/Drop Capability

This provides the capability to add/drop lower speed channels from an OC-48 Dedicated Ring node location via OC-12 and OC-3 ports. OC-48 Add/Drop Capability at an OC-48 Dedicated Ring Service node location will support one quarter of the port capability of OC-48 ring bandwidth. Up to four OC-48 Add/Drop Capability options may be provided at a node with each option supporting one OC-12 port, up to four OC-3 ports, up to twelve DS3 ports, or equivalent combination of OC-3 and DS3 ports, or up to twelve 100 Mbps (STS-1) Ethernet ports or up to four 100 Mbps (STS-3c) Ethernet ports or up to eight 1 Gbps (STS-1) Ethernet ports or up to four 1 Gbps (STS-3c) ports or one 1 Gbps (STS-12c) Ethernet port.

OC-48 Add/Drop Capability associated with OC-48 Dedicated Ring nodes that qualify as "Plus"⁽¹⁾ nodes as defined in Section 7.2.11(B)(1) will be billed as "Plus"⁽¹⁾ as shown in Section 7.5.11.

(T)
(T)

⁽¹⁾ Effective 03/18/06, the OC-48 "Plus" feature will no longer be available to new customers. There will be no changes to existing customers.

⁽²⁾ Effective August 1, 2013, availability of Re-Map nodes is limited to Re-Map nodes that are in service or have been ordered prior to August 1, 2013.

For OC-48 SONET Rings established prior to 03/24/05, the Add/Drop Capability charge is applied per quarter (12 DS-3 equivalent) port capability of ring. Customers may upgrade their ring when new TPP is equal to or greater than their existing TPP and the new MRC revenue is equal to or greater than their existing MRC revenue.

For OC-48 SONET Rings established after 03/24/05, the Add/Drop Capability charge is applied only once and only when the 25th DS-3 port is applied per node.

(b) OC-192 Add/Drop Capability

This provides the capability to add/drop lower speed channels from an OC-192 Dedicated Ring node location via OC-48 or OC-12 ports. OC-192 Add/Drop Capability at an OC-192 Dedicated Ring Service node location will support up to four OC-48 or OC-48c ports, or up to sixteen OC-12 or OC-12c ports, or up to sixty four OC-3 or OC-3c ports, or up to 192 DS3 ports or various combinations not to exceed 192 STS-1 equivalents, or up to forty-eight 100 Mbps (STS-1) Ethernet ports or up to sixteen 100 Mbps (STS-3c) Ethernet ports or up to thirty-two 1 Gbps (STS-1) Ethernet ports or up to sixteen 1 Gbps (STS-3c) Ethernet ports or up to two 1 Gbps (STS-12c) ports or up to two 1 Gbps (STS-24c) ports.

The OC-192 Add/Drop Capability charge is applied to all nodes, excluding regenerators and CO nodes without drop ports.

(3) Ports

The type of ports available on the family of rings is DS3, STS-1, EC-1, OC-3, OC-3c, OC-12, OC-12c, OC-48, OC-48c, OC-192, 100 Mbps (STS-1) Ethernet, 100 Mbps (STS-3c) Ethernet, 1 Gbps (STS-1) Ethernet, 1 Gbps (STS-3c) Ethernet, 1 Gbps (STS-12c) Ethernet and 1 Gbps (STS-24c) Ethernet. The associated family of riding services are Point-to-Point OC-3, OC-3c, OC-12, OC-12c, OC-48 and OC-48c.

Ethernet over SONET (EoS) allows the efficient transport of ethernet frames using SONET. Ethernet ports will be available in bandwidths up to the ethernet interface of 100 Mbps or 1 Gbps on Dedicated Ring Services. As SONET bandwidths will be preset, the customer will be unable to transmit data (including any bursts) beyond these preset SONET bandwidths. Interfaces of 100 Mbps Ethernet or 1 Gbps Ethernet are available only to customers with Next Generation SONET equipment. Access into the Telephone Company's Ethernet ports must conform to industry standards and specifications as described in technical publication SBC-TP-76412-000. Only Single-Mode Fiber is available in the Central Office. The EoS line rates, defined in Section 7.5.11 (D), are based on the theoretical SONET payload line rates as per GR-253-CORE, Issue 4. These values are not representative of the true Ethernet transport capacity of the EoS circuit.

Accepted interfaces are as follows:

	OC-3 Node	OC-12 Node	OC-48 Node	OC-192 Node
DS1 Ports	x (Max. 84/Node)	x (Max. 84/OC-3 or OC-3c Ports) ⁽¹⁾	x (Max. 84/OC-3 or OC-3c Ports) ⁽¹⁾	x (Max.84/OC-3 Port)
DS3 Ports	x(Max. 3/Node)	x(Max. 12/Node)	x(Max. 48/Node)	X(Max.192/Node)
EC-1 Ports	X(Max. 3/Node)	X(Max. 12 Node)	X(Max. 48/Node)	X(Max.192/Node)
OC-3, OC-3c Ports ⁽²⁾	X(Max. 1/Node)	x (Max 4/Node)	x (Max 16/Node)	X (Max.64/Node)
OC-12, OC-12c Ports ⁽²⁾	N/A	x (Max. 1/Node)	x (Max 4/Node)	X (Max.16/Node)
OC-48, OC-48c Ports ⁽²⁾	N/A	N/A	x (Max. 1/Node)	X (Max. 4/Node)
OC-192 Ports ⁽²⁾	N/A	N/A	N/A	x (Max. 1/Node)
100 Mbps (STS-1) Ethernet Ports	x (Max 3/Node)	x (Max 12/Node)	x (Max 48/Node)	X (Max.192/Node)
100 Mbps (STS-3c) Ethernet Ports	N/A	x (Max 4/Node)	x (Max 16/Node)	x (Max.64/Node)
1Gbps (STS-1) Ethernet Ports	x (Max.3/Node)	x (Max 12/Node)	x (Max.48/Node)	x (Max.192/Node)
1Gbps (STS-3c) Ethernet Ports	N/A	x (Max 4/Node)	x (Max 16/Node)	x (Max.64/Node)
1Gbps (STS-12c) Ethernet Ports	N/A	N/A	x (Max 4/Node)	x (Max.16/Node)
1Gbps (STS- 24c) Ethernet Ports	N/A	N/A	x (Max 2/Node)	x (Max.8/Node)
10/100 BaseT Ethernet Port				
VT1.5-1v (1.6 Mbps)	X (Max. 84/Node)	X (Max. 84/OC-3)	X (Max. 84/OC-3)	X (Max. 84/OC-3)
VT1.5-2v (3.2 Mbps)	X (Max. 42/Node)	X (Max. 42/OC-3)	X (Max. 42/OC-3)	X (Max. 42/OC-3)
VT1.5-3v (4.8 Mbps)	X (Max. 28/Node)	X (Max. 28/OC-3)	X (Max. 28/OC-3)	X (Max. 28/OC-3)
VT1.5-4v (6.4 Mbps)	X (Max. 21/Node)	X (Max. 21/OC-3)	X (Max. 21/OC-3)	X (Max. 21/OC-3)
VT1.5-5v (8.0 Mbps)	X (Max. 16/Node)	X (Max. 16/OC-3)	X (Max. 16/OC-3)	X (Max. 16/OC-3)
VT1.5-6v (9.6 Mbps)	X (Max. 14/Node)	X (Max. 14-OC-3)	X (Max. 14-OC-3)	X (Max. 14-OC-3)
VT1.5-7v (11.2 Mbps)	X (Max. 12/Node)	X (Max. 12/OC-3)	X (Max. 12/OC-3)	X (Max. 12/OC-3)
VT1.5-8v (12.40 Mbps)	X (Max. 10/Node)	X (Max. 10/OC-3)	X (Max. 10/OC-3)	X (Max. 10/OC-3)
VT1.5-10v (16.0 Mbps)	X (Max. 8/Node)	X (Max. 8/OC-3)	X (Max. 8/OC-3)	X (Max. 8/OC-3)
VT1.5-13v (20.8 Mbps)	X (Max. 6/Node)	X (Max. 6/OC-3)	X (Max. 6/OC-3)	X (Max. 6/OC-3)
STS-1-1v (48.38 Mbps)	X (Max. 3/Node)	X (Max. 12/Node)	X (Max. 48/Node)	X (Max. 192/Node)
STS-1-2v (96.77 Mbps)	X (Max. 1/Node)	X (Max. 6/Node)	X (Max. 24/Node)	X (Max. 96/Node)
STS-1-3v (145.15 Mbps)	X (Max. 1/Node)	X (Max. 4/Node)	X (Max. 16/Node)	X (Max. 64/Node)
STS-1-4v (193.54 Mbps)	N/A	X (Max. 3/Node)	X (Max. 12/Node)	X (Max. 48/Node)
STS-1-5v (241.92 Mbps)	N/A	X (Max. 2/Node)	X (Max. 9/Node)	X (Max. 38/Node)
STS-1-6v (290.30 Mbps)	N/A	X (Max. 2/Node)	X (Max. 8/Node)	X (Max. 32/Node)
STS 1-9v (435.46 Mbps)	N/A	X (Max. 1/Node)	X (Max. 5/Node)	X (Max. 21/Node)
STS-1-12v (580.61 Mbps)	N/A	X (Max. 1/Node)	X (Max. 4/Node)	X (Max. 16/Node)
STS-1-21v (1016.06 Mbps)	N/A	N/A	X (Max. 2/Node)	X (Max. 9/Node)
STS-3c-1v (149.76 Mbps)	N/A	X (Max. 4/Node)	X (Max. 16/Node)	X (Max. 64/Node)
STS-3c-2v (299.52 Mbps)	N/A	X (Max. 2/Node)	X (Max. 8/Node)	X (Max. 32/Node)
STS-3c-3v (449.28 Mbps)	N/A	X (Max. 1/Node)	X (Max. 5/Node)	X (Max. 21/Node)
STS-3c-4v (599.04 Mbps)	N/A	X (Max. 1/Node)	X (Max. 4/Node)	X (Max. 16/Node)
STS-3c-7v (1048.32 Mbps)	N/A	N/A	X (Max. 2/Node)	X (Max. 9/Node)

(1) Optical to Electrical DS1 Add/Drop Capability as described in 7.2.11 (B) (5) is needed along with an OC-3 port unless the customer has chosen an OC-12 DDN.

(2) OC-3 and OC-3c ports support both OC-3 and OC-3c bandwidths. OC-12 and OC-12c ports support both OC-12 and OC-12c bandwidths. OC-48 and OC-48c ports support both OC-48 and OC-48c bandwidths. OC-192 and OC-192c ports support both OC-192 and OC-192c bandwidths.

By using the existing OC-3 or OC-3c, OC-12 or OC-12c or OC-48 or OC-48c Service and cross-connection capability, OC-3 or OC-3c point-to-point service may connect to an OC-3 or OC-3c port of an OC-12, OC-48 or OC-192 ring. OC-12 or OC-12c point-to-point service may connect to an OC-12 or OC-12c port of an OC-48, OC-192 ring, or OC-48. OC-48 or OC-48c point-to-point service may connect to an OC-48 or OC-48c port of an OC-192 ring located in a Company CO.

As described in Section 7.2.10 for OC-3, OC-3c Service, an OC-3 port will permit the connection of STS-1 channels to other STS-1 channels across the OC-12, OC-48 or OC-192 Dedicated Ring Service subject to the overall ring capacity limits described in Section 7.2.11(B)(6). Also an STS-1 channel with DS1 payload mapping accessing an OC-12 Dedicated Ring using an OC-3 port may be connected to the Optical to Electrical DS1 add/drop capability for the purpose of connecting up to 28 DS1 ports. An STS-1 channel with DS3 payload mapping accessing the OC-12 or OC-48 Dedicated Ring using an OC-3 port may individually connect to a DS3 or EC-1 port.

(T)

When a customer orders a Re-Map node⁽¹⁾, a minimum number of Re-Map ports must be equipped; (N)

- OC-3 28 DS1 Re-Map ports, or 1 DS3 Re-Map port
- OC-12 28 DS1 Re-Map ports, or 3 DS3 Re-Map ports, or 1 OC-3 or OC-3c Re-Map port
- OC-48 28 DS1 Re-Map ports, or 3 DS3 Re-Map ports, or 1 OC-3 or OC-3c Re-Map port, or 1 OC-12 Re-Map port

Re-Map node ports⁽¹⁾ must be ordered in incremental blocks as described below:

	Port Type					
	DS1	DS3	OC-3 or OC-3c	OC-12 or OC-12c	OC-48	OC-192
OC-3 Ring	28, 56 or 84 (multiples of 28)	1, 2, or 3	N/A	N/A	N/A	N/A
OC-12 Ring	28, 56 or 84 (multiples of 28)	3, 6, 9, or 12	1, 2, 3, or 4	1	N/A	N/A
OC-48 Ring	28, 56 or 84 (multiples of 28)	3, 6, 9... or 48	1, 2, 3... or 16	1, 2, 3 or 4	1	N/A
OC-192 Ring	28, 56 or 84 (multiples of 28)	3, 6, 9...or 192	1, 2, 3, 16... or 64	1, 2, 3, 4...or 16	1, 2, 3 or 4	1

An OC-12 or OC-48 ring utilizing re-map requires an OC-3 or OC-3c Re-Map port and DS1 Re-Map Add/Drop Capability to support DS1 port types. (An OC-3 or OC-3c Re-Map port and DS1 Re-Map Add/Drop Capability supports up to 84 DS1's.)

When utilizing an OC-12 Direct Drop Node for provisioning a re-map node, either 28 DS1 Re-Map ports or 1 DS3 Re-Map port will be the minimum required.

Transmux

DS3 Transmux is available on all speeds and provides the ability to aggregate multiple DS1s to a DS3 within the SONET Ring and also on a single card. DS1s are aggregated across the SONET network and terminated into a single DS3 card at a ring node. The hand-off will be a channelized DS3. Aggregation of DS1s can occur across multiple DS3/STSSs.

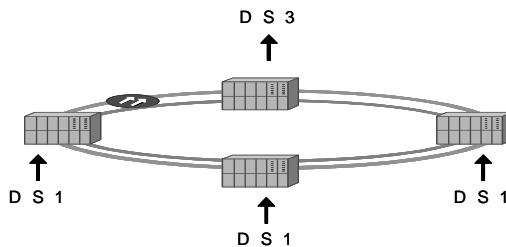

⁽¹⁾ Effective August 1, 2013, availability of Re-Map nodes is limited to Re-Map nodes that are in service or have been ordered prior to August 1, 2013. (N)

(i) Electrical Connection - Level 1 (EC-1)

EC-1 is an electrical interface that can transport up to 51.84 Mb of bandwidth in a concatenated format. The EC-1 port is available on an OC-3, OC-12, OC-48 and OC-192 ring. For the above connection capacity charts, the quantity of EC-1 ports is equivalent to the connection capacity of a DS-3.

(4) Mileage

Mileage is the total airline distance between the serving wire center of each node involved on the ring. A one-mile minimum will be billed between nodes. A two-node ring configuration has a two-mile minimum - one mile from the wire center node to the customer premises node, and one mile from the customer premises node to the wire center node.

In addition, interoffice transport can be connected between wire centers at a lower OC-N speed than the Dedicated Ring, if the transport is between a dedicated ring port and:

- a lower speed Add/Drop Function;
- a lower speed Local Distribution Channel
- another lower speed Dedicated Ring Port; or
- a lower speed Cross-Connect

(5) Optical-to-Electrical Add/Drop Capability

- (a) Optical-to-Electrical DS1⁽¹⁾ Add/Drop Capability allows an electrical DS1 to be derived from an optical OC-12, OC-48, or OC-192 ring by using this capability to add/drop the electrical DS1 from an OC-3 port.

For SONET Rings established after 03/24/05, the Optical-to-Electrical DS-1 Add/Drop Capability charge is applied when the 85th DS-1 port is required per OC-12 node and when the 29th DS-1 port is required per OC-48 or OC-192 node. Additional charges will apply per each increment of 84 DS-1 ports.

Effective 06/10/06, Optical-to-Electrical DS-1 Add/Drop Capability will be available from an optical OC-192 shelf.

- (b) Optical-to-Electrical DS3 Add/Drop Capability allows an electrical DS3 to be derived from an OC-192 ring via an optical OC-3, OC-12 or OC-48 shelf. The manner in which a DS3 is dropped will be designed based on forecast and equipment hierarchy.

For OC-192 SONET Rings established prior to 03/24/05, when electrical drops are required, the Optical-to-Electrical DS-3 Add/Drop Capability charge is applied in addition to the Add/Drop Capability charge as described in Section 7.2.11(B) (2) (b).

For OC-192 SONET Rings established after 03/24/05, the Optical-to-Electrical DS-3 Add/Drop Capability charge is applied only once and only when the 25th DS-3 port is applied per node.

(1) Optical-to-Electrical DS1 Add/Drop Capability as described in 7.2.11 (B) (5) (a) is needed along with an OC-3 port unless the customer has chosen an OC-12 DDN.

(6) Dedicated Ring Regenerator

Regenerators provide essential detection and retransmission of SONET Optical 155.52 Mbps, 622.08 Mbps, 2488.32 Mbps and 9953.28 Mbps signals between nodes. Regenerators will only be provided as required by the Telephone Company when actual fiber facility distances between nodes exceed inter-nodal design limits. Regenerators will be located exclusively in Telephone Company COs and do not allow ports to access customer service connections.

(7) Dedicated Ring Connection Capacity

Maximum transport capacity of OC-3, OC-12, OC-48 and OC-192 Dedicated Ring Service is characterized by the total quantity of individual port-to-port connections allowed between all nodes on the ring. The DS3 Port connections shown below in this section can be exchanged with EC-1 Port connections.

For OC-3 Dedicated Ring Service, the maximum ring capacity will be equal to one of the following combinations:

DS3 Port to DS3 Port Connections	and	DS1 Port to DS1 Port Connections
Three	and	None
Two	and	Up to 28
One	and	Up to 56
None	and	Up to 84

An OC-3 sub-ring or Arc sub-ring provided as part of OC-12 or OC-48 Dedicated Ring Service has a maximum capacity equal to one of the above combinations.

For OC-3 Dedicated Ring Service and OC-3 sub-rings or Arc sub-rings, as part of OC-12 or OC-48 Dedicated Ring Service, individual DS1 port-to-DS1 port and DS3 port-to-DS3 port connections capacities may be incrementally distributed between nodes on the ring in any manner.

For OC-12 Dedicated Ring Service, the maximum ring capacity will be equal to one of the following combinations:

DS3 Port to DS3 Port Connections	and	DS1 Port to DS1 Port Connections
Twelve	and	None
Eleven	and	One Group of 28
Ten	and	Two Groups of 28 (56)
Nine	and	Three Groups of 28 (84)
Eight	and	Four Groups of 28 (112)
Seven	and	Five Groups of 28 (140)

Six	and	Six Groups of 28 (168)
Five	and	Seven Groups of 28 (196)
Four	and	Eight Groups of 28 (224)
Three	and	Nine Groups of 28 (252)
Two	and	Ten Groups of 28 (280)
One	and	Eleven Groups of 28 (308)
None	and	Twelve Groups of 28 (336)

An OC-12 sub-ring or Arc sub-ring provided as part of OC-48 Dedicated Ring Service has a maximum capacity equal to one of the above combinations.

For OC-12 Dedicated Ring Service and OC-12 sub-rings or Arc sub-rings as part of OC-48 Dedicated Ring Service, individual DS1 port-to-DS1 port connection and DS3 port-to-port connection may be incrementally distributed between nodes on the ring in any manner.

For OC-12 Dedicated Ring Service using OC-12 Direct Drop Nodes⁽¹⁾, the maximum ring capacity will be up to 84 DS1 port-to-port connections, together with up to 9 DS3 port-to-port connections, or equivalent. Individual DS1 port-to-port connections up to a total of 84 may be incrementally distributed between OC-12 Direct Drop Nodes on the ring in any manner.

(1) Effective 03/18/06, the Direct Drop Node feature will no longer be available to new customers. There will be no change to existing customers.

OC-12 Dedicated Ring Service will also provide capability for node-to-node connection of STS-1 or STS-3C channels using OC-3 or OC-3c ports on the OC-12 ring. Each STS-1 to STS-1 channel connection or STS-1 channel to DS3 port connection requested by the customer will reduce the remaining ring capacity by the equivalent of one DS3 port-to-DS3 port connection or 28 DS1 port-to-DS1 port connections. Each STS-3C to STS-3C channel connection requested by the customer will reduce the remaining ring capacity by the equivalent of three DS3 port-to-DS3 port connections or 84 DS1 port-to-DS1 port connections.

An OC-3 Sub-ring provided as part of an OC-12 Dedicated Ring Service reduces the remaining OC-12 ring capacity by the equivalent of three DS3 port-to-DS3 port connections or 84 DS1 port-to-DS1 port connections.

For OC-48 Dedicated Ring Service, the maximum ring capacity will be equal to one of the following combinations:

DS3 Port-to-DS3 Port DS1 Port Connections	and	DS1 Port-to- Connections
Forty-eight	and	None
Forty-seven	and	One Group of 28
Forty-six	and	Two Groups of 28 (56)
Forty-five	and	Three Groups of 28 (84)
Forty-four	and	Four Groups of 28 (112)
Forty-three	and	Five Groups of 28 (140)
Forty-two	and	Six Groups of 28 (168)

DS3 Port-to-DS3 Port DS1 Port Connections	and	DS1 Port-to- Connections
Forty-one	and	Seven Groups of 28 (196)
Forty	and	Eight Groups of 28 (224)
Thirty-nine	and	Nine Groups of 28 (252)
Thirty-eight	and	Ten Groups of 28 (280)
Thirty-seven	and	Eleven Groups of 28 (308)
Thirty-six	and	Twelve Groups of 28 (336)
Continuing down the scale to: None and Forty-eight Groups of 28 (1344)		

For OC-48 Dedicated Ring Service, individual DS1 port-to-DS1 port connection capacities may be distributed only in incremental groups of 28 between any two nodes on the ring. Individual DS3 port-to-DS3 port connection capacities may be incrementally distributed between nodes on the ring in any manner.

OC-48 Dedicated Ring Service also provides capability for node-to-node connection of STS-1 or STS-3C channels using OC-3, OC-3c, OC-12, OC-12c, 100 Mbps Ethernet or 1 Gbps Ethernet ports on the OC-48 ring. Each STS-1 to STS-1 channel connection or STS-1 channel to DS3 port connection requested by the customer reduces the remaining ring capacity by the equivalent of one DS3 port-to-port connection or 28 DS1 port-to-port connections. Each STS-3C to STS-3C channel connection requested by the customer reduces the remaining ring capacity by the equivalent of three DS3 port-to-DS3 port connections or 84 DS1 port-to-port connections.

An OC-3 Sub-ring provided as part of OC-48 Dedicated Ring Service reduces the remaining OC-48 ring capacity by the equivalent of three DS3 port-to-DS3 port connections or 84 DS1 port-to-DS1 port connections.

OC-48 Dedicated Ring Service also provides capability for node-to-node connections of STS-12C channels using OC-12 or OC-12c ports on the OC-48 ring. Each STS-12C to STS-12C channel connection requested by the customer reduces the remaining ring capacity by the equivalent of twelve DS3 port-to-DS3 port connections or 336 DS1-to-DS1 port connections.

An OC-12 Sub-ring provided as part of OC-48 Dedicated Ring Service reduces the remaining OC-48 ring capacity by the equivalent of twelve DS3 port-to-DS3 port connections or 336 DS1 port-to-DS1 port connections.

For OC-192 Dedicated Ring Service, the maximum ring capacity between nodes is not to exceed 96 STS-1 equivalents.

OC-192 Dedicated Ring Service will provide capability for node-to-node connection of STS-1 or STS-3C channels using OC-3, OC-3c, OC-12, OC-12c, OC-48, OC-48c, 100 Mbps Ethernet or 1 Gbps Ethernet ports on the OC-192 ring.

OC-192 Dedicated Ring Service will also provide capability for node-to-node connections of STS-12C channels using OC-12, OC-12c, OC-48, OC-48c or 1 Gbps Ethernet ports on the OC-192 ring.

OC-192 Dedicated Ring Service will also provide capability for node-to-node connections of STS-48C channels using OC-48 or OC-48c ports on the OC-192 ring.

Virtual Concatenation (VCAT) provides the ability and flexibility to size the customer's bandwidth, sub-rate VT1.5 and super-rate STS-1 and 3c service payloads, based on their traffic requirements. For transport of payloads that do not fit efficiently into the standard set of VT1.5, STS-1 and STS-Nc payload envelopes, virtual concatenation can be used.

The maximum transport capacity of an OC-3, OC-12 or OC-48 sub-ring or Arc sub-ring is characterized by the total quantity of individual port connections allowed between all nodes on the ring. Refer to DSRS Section 7.2.11(B) (7) for combinations.

Unprotected services may be interrupted to repair other circuits. In cases where the customer orders OC-192 Dedicated Ring Service with an unprotected 2-fiber service interface, the Telephone Company may provision this unprotected service, with other unprotected services, via a multi-port circuit card. If one unprotected service on the card incurs an outage, the Telephone Company may repair the 2-fiber service interface device by replacing the card, which may temporarily interrupt service on any other unprotected tributary circuits that subtend this same multi-port circuit card. In the event of a service interruption, credit allowance will be provided for the service that suffered the unplanned outage, as outlined in Section 7.2.11(A) (1), previously.

(8) Diagram OC-3, OC-12 and OC-48 Ring

OC-3 Dedicated Ring Service

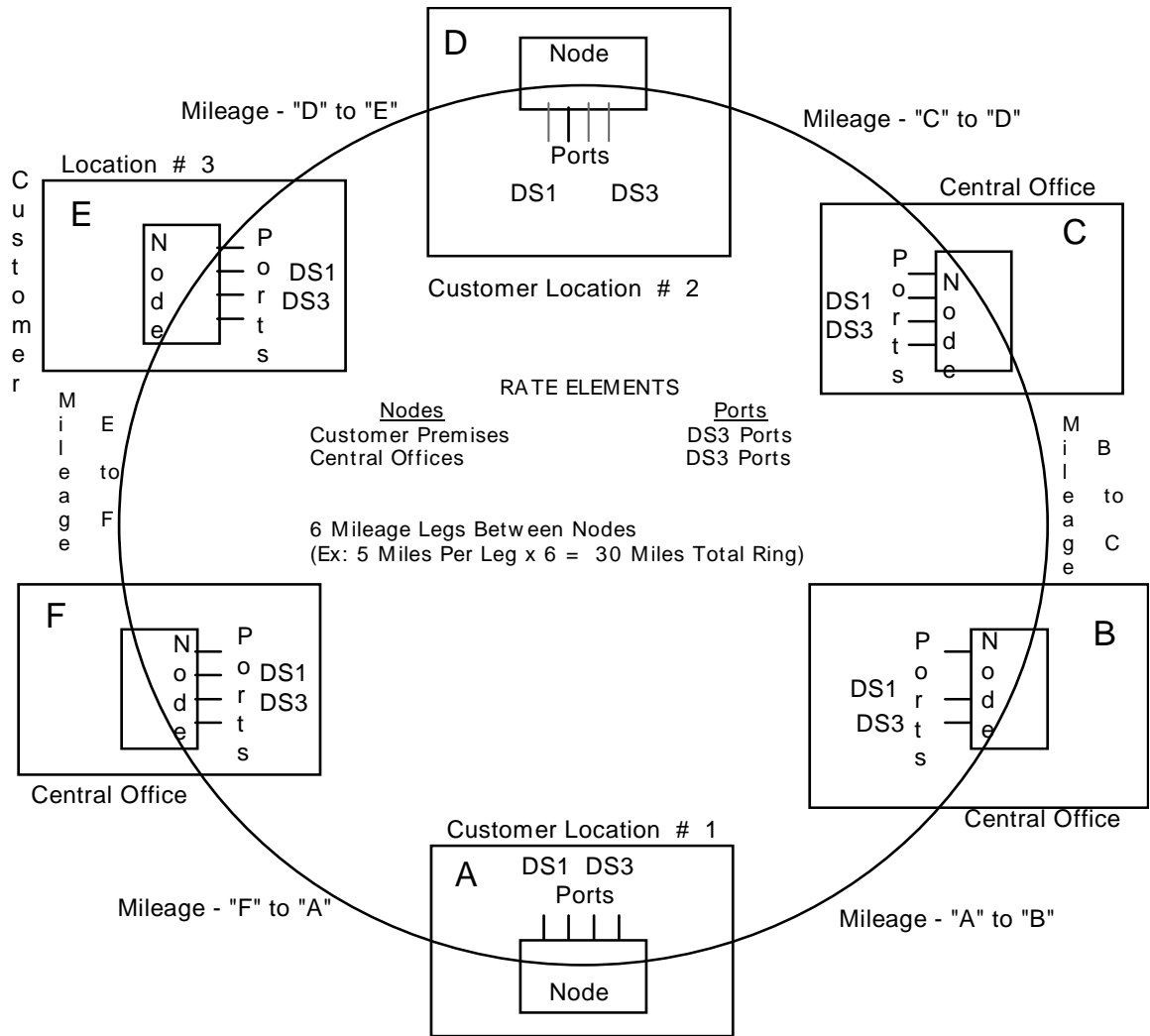

OC-12 Dedicated Ring Service

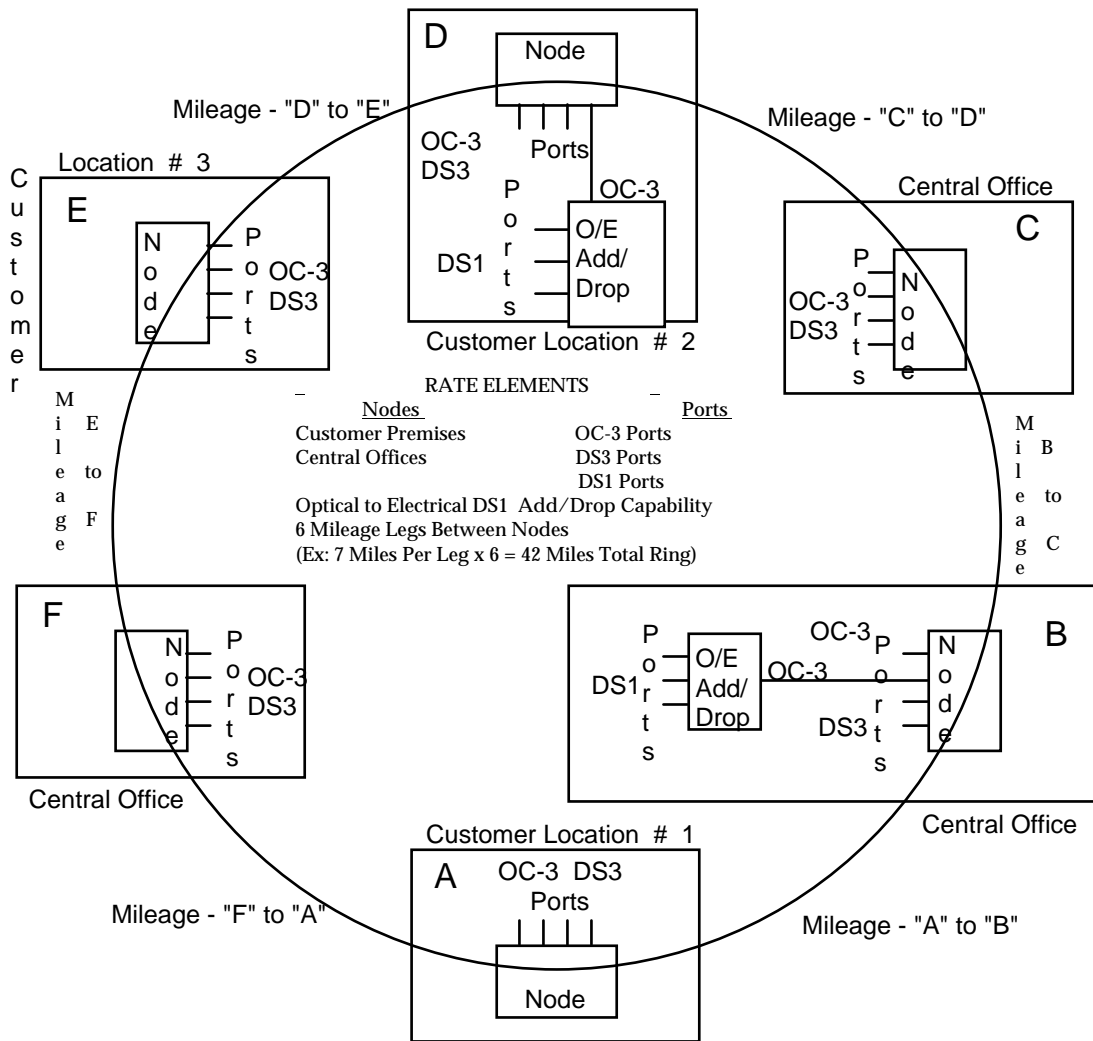

OC-48 Dedicated Ring Service

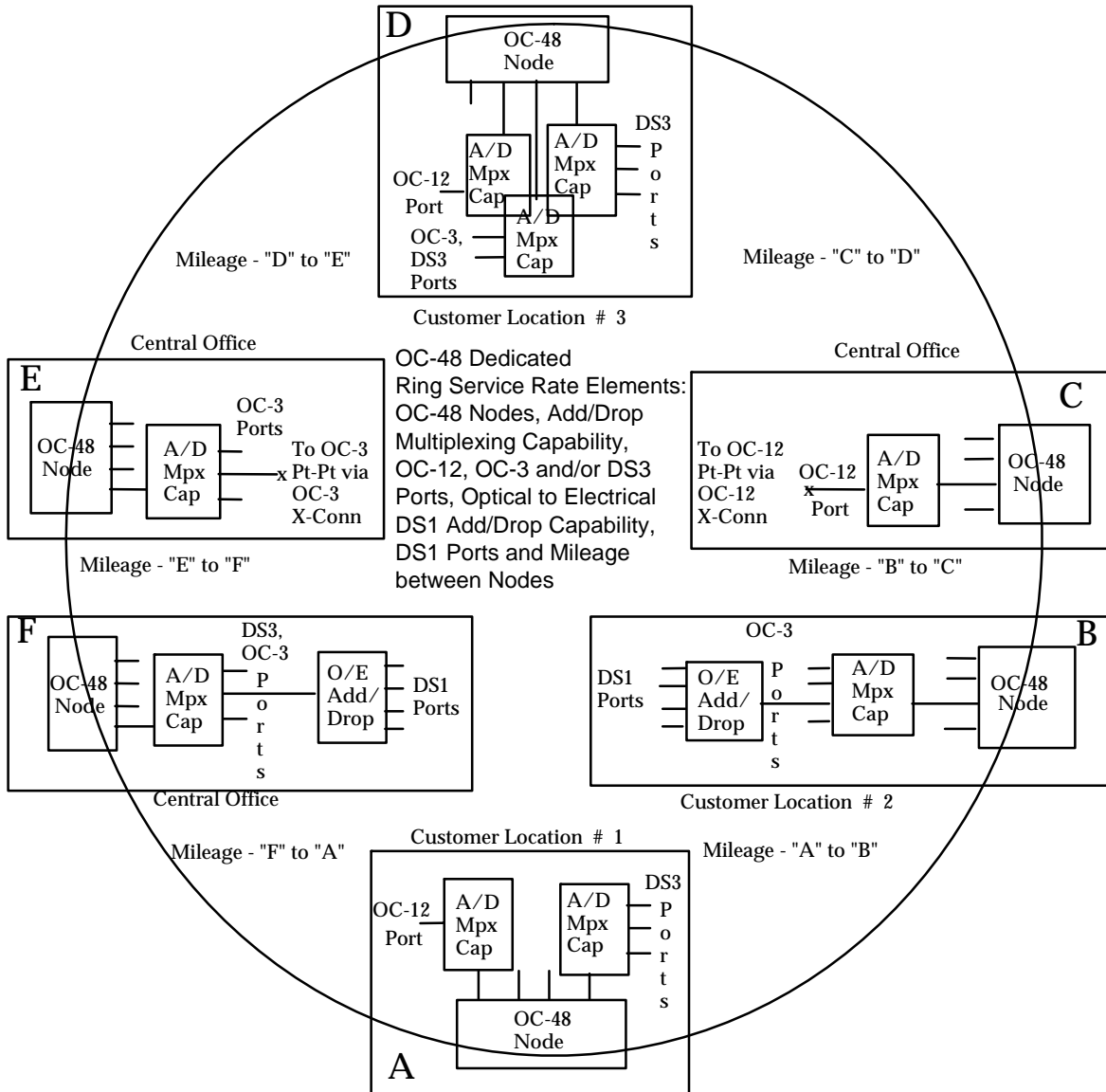

Ameritech Sub-Ring Nodes

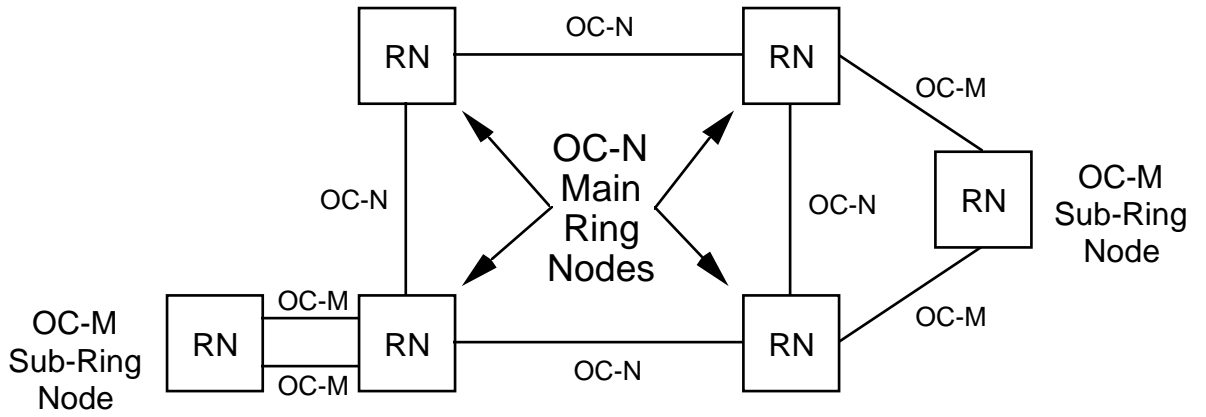

Ameritech Sub-Ring Nodes, OC-M < OC-N

ARC Sub-Ring Nodes, $OC-m < OC-n$

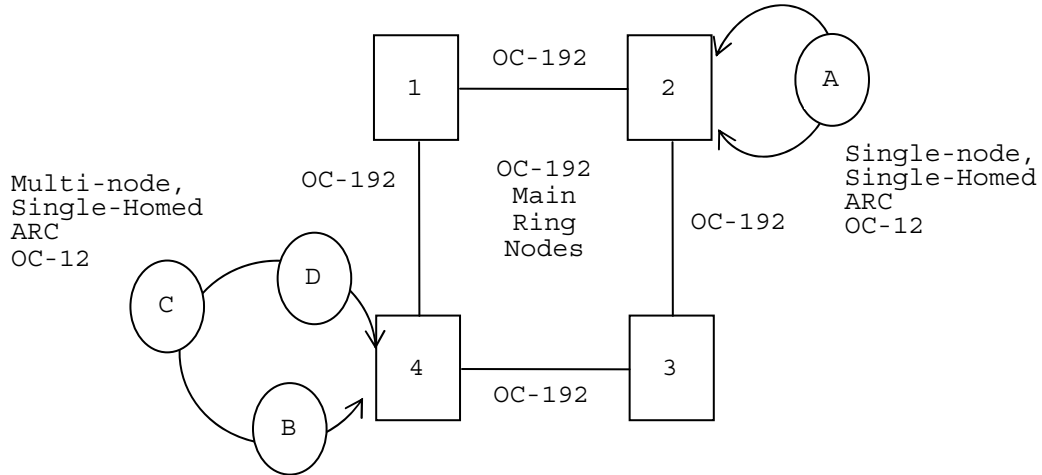

ARC Sub-Ring Nodes, $OC-M < OC-N$

OC-192 Dedicated Ring shown as example.

(9) Optional Payment Plan⁽¹⁾

Dedicated Rings are available for either 36 month or 60 month⁽²⁾ periods. Monthly recurring charges apply for the nodes, ports and mileage between nodes. If a node is added after the initial installation of the dedicated ring, the new node will carry the same OPP rate as the initial ring and be co-terminus with that OPP. However, if a node is added during the last 12 months or less of an OPP, the customer will be billed the initial OPP ring rate for a minimum period of 12 months. Once an OPP term has expired, the customer's service will convert to the Monthly Extension rate until the customer cancels or renews the service with a new OPP term. To renew the service, the customer must provide the Telephone Company with a written notice of intent to renew the OPP no later than 60 days prior to its expiration. Monthly Extension Rates are not available to new subscriptions. The OPP prepayment option is not available with this service. The OPP prepayment option is not available with this service. (C)

Effective September 5, 2003, new orders for Dedicated Ring Service with the EoS enhancement will be served by different equipment than the equipment used for customers who placed Dedicated Ring Service orders that were completed prior to September 5, 2003. Customers subscribing to Dedicated Ring Service prior to September 5, 2003 requesting to be changed to the new equipment will incur termination liability charges for their existing service. Disconnect of the existing Dedicated Ring Service and placement of an order for new Dedicated Ring Service with the EoS enhancement is required. The monthly rates for the new service(s) shall be those rates in effect at the time the new service(s) are installed.

For service purchased prior to August 4, 2000, Termination Liability charges will apply for the Node only as described below by paying a percentage of the monthly charges for the remainder of the term as indicated below:

OPP Terms in Months ⁽²⁾	Termination Percentage	(C)
36	75	
60	60	

⁽¹⁾ All term plans for OC-3, OC-12, OC-48 and OC-192 Dedicated Ring service which are established or renewed after November 9, 2013, for term lengths which are scheduled to expire at any time after February 1, 2019, will instead expire on February 1, 2019. All such services existing on or after February 1, 2019, will be provided on a month-to-month basis at the applicable, then current month-to-month rates. Notwithstanding anything to the contrary in the previous two sentences, this footnote does not apply to any term plans established or renewed after July 15, 2017.

⁽²⁾ Effective on August 21, 2018, AT&T will no longer offer term plans longer than 36 months, including any renewals, extensions or conversions of existing term commitments. (N)
 (N)

If a customer cancels a service order or terminates services before the completion of the term for any reason whatsoever other than a service interruption, the customer agrees to pay to the Telephone Company termination liability charges, which are defined below. These charges shall become due and owing as of the effective date of the cancellation or termination and are payable within 30 days of the invoice date, subject to interest penalty on the unpaid balance.

Customer's termination liability for cancellation of service shall be equal to:

- (a) All waived and/or unpaid nonrecurring charges, plus;
- (b) 50% of all recurring charges for the balance of the customer's term.

Logical Changes in the ring (change in mapping content) are not considered to be a dedicated ring termination, however, any physical change would be considered a termination and all appropriate termination liability would apply.

(10) Shared Network Arrangement⁽¹⁾

A Shared Network Arrangement is a service offering that enables a customer ("Service User") to connect subtending services to an OC-3, OC-12, OC-48 or OC-192 Dedicated Ring service of another customer (the "Host Subscriber"), with the Telephone Company maintaining separate billing for each. Each customer will be billed for those rate elements associated with their own portion of the service configuration. The Host Subscriber will be responsible for all Dedicated Ring Service rate elements, for example, node, ports and mileage, etc. Under no circumstances will the rates or charges for individual rate elements be split. This offering is limited to service configuration where a Service User orders a subtending service dropped from a Host subscriber's Dedicated Ring wire center node.

Under the Shared Network Arrangement, the Telephone Company may share record information with the Host Subscriber pertaining to the services of other users of the shared network. Such disclosure will be under the sole discretion of the Telephone Company and is necessary to perform billing reconciliation and/or other functions required in connection with maintaining account records.

Part 2, Section 7 of this Guidebook contains rate conditions specific to Shared Network Arrangements.

(T)

(1) Effective 05/26/06, this condition is limited to existing customers. For new customers purchasing Shared Network Arrangement, terms and conditions set forth in Part 2, Section 5 of this Guidebook, will apply.

(T)

(11) Re-Map Service⁽¹⁾

(N)

Re-Map Service is provided in conjunction with an Ameritech Dedicated Ring Service and allows for a pre-defined set of services to be rerouted by Ameritech from one customer premises node to another customer premises node (defined as a "Re-Map node") in the event of a customer premises disaster. Re-Map Service will be tested at initial installation and once each year thereafter. Additional testing can be requested and will be charged on a per test basis. Activation upon customer request in the event of an emergency will be charged on a per occurrence basis.

Once the customer notifies Ameritech that they are ready to receive signals at the re-map node site, Ameritech will re-map up to 50 circuits within the initial hours and 20 circuits every hour thereafter. The Emergency Activation Nonrecurring Charge will not be applied if the first 50 circuits are not remapped within 4 hours due to an Ameritech caused delay.

Re-Map testing or activation for OC-12 or OC-48 service requires a minimum incremental group from 1 to 28 DS1s or one DS3 (equals one STS-1) between one customer premises node and the Re-Map node.

The emergency Re-Map activation configuration will be maintained for up to 30 days. After 30 days, if the customer wishes to maintain the emergency configuration, the emergency activation NRC will be applied once for each 30 day additional period.

Re-Map Service is available on Self-Healing Uni-Directional Path Switched Rings (UPSR) only.

(12) STS-1 Service

The STS-1 circuit allows the efficient transport of up to 51.84 Mbps of bandwidth across Dedicated SONET Ring utilizing EC-1 (Electrical Connection - Level 1) ports on the dedicated service. While the EC-1 port is comparable to the DS-3 port as far as the connection capacity per STS, the STS-1 circuit utilizes the entire bandwidth of the STS (51.84 Mbps) while the DS-3 uses 44.76 Mbps of the STS. The STS-1 circuit is available via EC-1 ports on OC-3, OC-12, OC-48 and OC-192 rings.

⁽¹⁾ Effective August 1, 2013, availability of Re-Map nodes is limited to Re-Map nodes that are in service or have been ordered prior to August 1, 2013.

(N)

(N)

(13) Unprotected Channel Transport (UCT)

UCT will allow customers to transport traffic (DS-1, DS-3, up to OC-48), over a ring without enabling SONET protection schemes. This is intended for applications in which the customer provides protection for the circuit through means other than those available through SONET. If a fault occurs on the ring along the transport path, the traffic will not be switched to a protection channel. Service will be interrupted on that circuit until the fault is corrected. The customer is required to call in and open a trouble ticket for the unprotected service. If a fault occurs in the ring, but does not occur along the transport route, service will not be interrupted on that circuit.

Customers who order Dedicated SONET Ring Service may need to replace or upgrade their existing service to invoke use of UCT for circuit assignments. Use of UCT is managed through a Special Routing Code (SRC) in relation to a circuit's Connecting Facility Assignment (CFA). When an Unprotected service is placed on a channel, the protection switching is shut off. When a UCT is disconnected, the channel will revert back to the standard protection mode.

(14) Upgrade to OC-192 Ring Service from lower speed services⁽²⁾

Customers with three or five year⁽³⁾ OPPs may at any time upgrade from OC-48 to OC-192 Dedicated SONET Ring Service without incurring the Termination Liability charge, providing the following criteria are met: (C)

- (1) The customer subscribes to a Term Pricing Plan period that is equal to, or greater than 36 months;⁽³⁾ (C)
- (2) The expiration date for the new Term Pricing Plan period is beyond the end of the original Optional Payment Plan period; (C)
- (3) No lapse in service occurs;
- (4) Nonrecurring Charges will apply;
- (5) The monthly rates for the new service(s) will be those rates in effect at the time the new service(s) is/are installed;
- (6) The new service is provided between the same customer locations and with the same customer of record as the disconnected service;
- (7) The original location of all nodes must be included in the new service;
- (8) Billed recurring revenue for each month of the first eighteen months of the new service is equal to or greater than the billed recurring revenue for the last month of the service(s) being converted;
- (9) Customer agrees not to convert the new service term pricing plan to a pricing plan with a lower rate for the period of eighteen months after the conversion;
- (10) Spare facilities and equipment must be available or a nonrecurring upfront payment, which is a Special Construction Charge, will apply; and
- (11) Existing service must have been in place for a minimum of 12 months.⁽¹⁾

⁽¹⁾ This criteria does not apply to term plans purchased prior to 03/18/06.

⁽²⁾ All term plans for OC-3, OC-12, OC-48 and OC-192 Dedicated Ring service which are established or renewed after November 9, 2013, for term lengths which are scheduled to expire at any time after February 1, 2019, will instead expire on February 1, 2019. All such services existing on or after February 1, 2019, will be provided on a month-to-month basis at the applicable, then current month-to-month rates. Notwithstanding anything to the contrary in the previous two sentences, this footnote does not apply to any term plans established or renewed after July 15, 2017.

⁽³⁾ Effective on August 21, 2018, AT&T will no longer offer term plans longer than 36 months, including any renewals, extensions or conversions of existing term commitments. (N)

(15) *Upgrade to Next Generation SONET equipment (required for Ethernet ports) ⁽¹⁾

Customers with three or five-year⁽²⁾ OPPs may at any time upgrade to Next Generation equipment without incurring Termination Liability charge, providing the following criteria are met: (C)

- The customer subscribes to a Term Plan period that is equal to, or greater than thirty-six months;⁽²⁾ (C)
- The expiration date for the new Term Plan period is beyond the end of the original Optional Payment Plan period;
- No lapse in service occurs;
- Nonrecurring charges will apply, when applicable;
- The monthly rates for the new service(s) will be those rates in effect at the time the new service(s) is/are installed;
- The new service is provided between the same customer locations and with the same customer of record as the disconnected service;
- The original location of all nodes must be included in the new service.
- Billed recurring revenue for each month of the first eighteen months of the new service is equal to or greater than the billed recurring revenue for the last month of the service(s) being converted.

* This option is limited to existing customers at existing locations purchased between September 5, 2003 and March 12, 2004.

(1) All term plans for OC-3, OC-12, OC-48 and OC-192 Dedicated Ring service which are established or renewed after November 9, 2013, for term lengths which are scheduled to expire at any time after February 1, 2019, will instead expire on February 1, 2019. All such services existing on or after February 1, 2019, will be provided on a month-to-month basis at the applicable, then current month-to-month rates. Notwithstanding anything to the contrary in the previous two sentences, this footnote does not apply to any term plans established or renewed after July 15, 2017.

(2) Effective on August 21, 2018, AT&T will no longer offer term plans longer than 36 months, including any renewals, extensions or conversions of existing term commitments. (N)
(N)

- (16) Upgrade to a higher speed Dedicated Ring with Next Generation SONET equipment (required for Ethernet ports) ⁽²⁾

Customers with three or five-year⁽³⁾ OPPs may at any time upgrade to a higher speed Dedicated Ring with Next Generation equipment without incurring Termination Liability charge, providing the following criteria are met: (C)

- (1) The customer subscribes to a Term Plan period that is equal to, or greater than thirty-six months; ⁽³⁾ (C)
- (2) The expiration date for the new Term Plan period is beyond the end of the original Optional Payment Plan period;
- (3) No lapse in service occurs;
- (4) Nonrecurring charges will apply;
- (5) The monthly rates for the new service(s) will be those rates in effect at the time the new service(s) is/are installed;
- (6) The new service is provided between the same customer locations and with the same customer of record as the disconnected service;
- (7) The original location of all nodes must be included in the new service;
- (7) Billed recurring revenue for each month of the first eighteen months of the new service is equal to or greater than the billed recurring revenue for the last month of the service(s) being converted; and
- (9) Existing service must have been in place for a minimum of 12 months. ⁽¹⁾

⁽¹⁾ This criteria does not apply to term plans purchased prior to 03/18/06.

⁽²⁾ All term plans for OC-3, OC-12, OC-48 and OC-192 Dedicated Ring service which are established or renewed after November 9, 2013, for term lengths which are scheduled to expire at any time after February 1, 2019, will instead expire on February 1, 2019. All such services existing on or after February 1, 2019, will be provided on a month-to-month basis at the applicable, then current month-to-month rates. Notwithstanding anything to the contrary in the previous two sentences, this footnote does not apply to any term plans established or renewed after July 15, 2017.

(3) Effective on August 21, 2018, AT&T will no longer offer term plans longer than 36 months, including any renewals, extensions or conversions of existing term commitments. (N)

(17) Renewal Options^{(1) (2)} (C)

Current OC-3, OC-12, OC-48, and OC-192 Dedicated Ring customers have the option to extend their 36 month or 60 month⁽²⁾ OPP Rates. Customers may extend their existing term as noted: (C)

- 36 month terms may be extended for an additional 24 month renewal term commitment at 36 month rates
- 60 month⁽²⁾ terms may be extended for an additional 36 month renewal term commitment at 60 month rates (C)

Customers must initiate a request for one of these Renewal options. After the first renewal term commitment is completed under these Renewal Options, rates will convert to monthly extension rates unless a 36 month or 60 month⁽²⁾ OPP is purchased. (C)

Qualification for these Renewal Options include eligible services meeting either of the requirements below:

- (1) Services that have expired and are currently on monthly extension rates

Customers currently on monthly extension rates are not eligible for retroactive treatment under these Renewal Options.

Termination Liability charges as contained in Section 7.2.11 will apply.

⁽¹⁾ All term plans for OC-3, OC-12, OC-48 and OC-192 Dedicated Ring service which are established or renewed after November 9, 2013, for term lengths which are scheduled to expire at any time after February 1, 2019, will instead expire on February 1, 2019. All such services existing on or after February 1, 2019, will be provided on a month-to-month basis at the applicable, then current month-to-month rates. Notwithstanding anything to the contrary in the previous two sentences, this footnote does not apply to any term plans established or renewed after July 15, 2017.

⁽²⁾ Effective on August 21, 2018, AT&T will no longer offer term plans longer than 36 months, including any renewals, extensions or conversions of existing term commitments. (N)
(N)

(C) Jointly Provided Service

(N)

(1) General

OC-12, OC-48, and OC-192 Dedicated Ring may be available in a meet-point billing arrangement involving another Incumbent Local Exchange Carrier (ILEC) (sometimes also referred to as an Independent Company or ICO), where suitable facilities exist and where appropriate procedures for such arrangement have been put in place between the Telephone Company and the other ILEC. When the Telephone Company and another ILEC jointly provide a meet-point ring arrangement, each ILEC involved shall provision and bill the portion of service located in its operating territory according to the terms and conditions of that ILEC's applicable tariffs or other service publications. Meet-point billing arrangements are not available for OC-3 Dedicated Ring.

(2) Ordering

The Customer shall order OC-12, OC-48, and OC-192 Dedicated Ring by issuing an access order, or by such other means for the exchange telephone companies to provision on the ring in each exchange telephone company territory. The Customer will place the order for service as set forth in the ordering conditions for the requested service.

(3) Credit Allowance for Service Interruption

OC-3, OC-12, OC-48, and OC-192 Dedicated Ring, provided in a meet-point arrangement, is subject to the general terms and conditions in Part 2, Section 2, including, without limitation, the exclusions applicable to Credit Allowances for Service Interruptions, as provided in Part 2, Section 2.5.6(F). As clarification, but not to modify any such terms and conditions, a Credit Allowance for Service Interruptions shall not apply to any service interruption resulting from any failure attributable to the other ILEC jointly providing the service or otherwise not attributable to the Telephone Company.

7.2.12 Section Not in Use

(N)

7.2.13 Gigabit Ethernet Metropolitan Area Network (GigaMAN®) ⁽¹⁾

(N)

(A) Basic Channel Description

GigaMAN® is a fiber based, point-to-point, gigabit Ethernet service that allows customers to transport data signals between local area networks (LANs). GigaMAN® transports data signals at the rate of 1 gigabit per second (Gbps). All basic service configurations provide a single direction of transmission.

The following conditions will apply to GigaMAN®:

- (1) This service is available to Customers in select areas within the LATAs served by the Telephone Company.
- (2) If existing facilities do not exist Special Construction may apply.
- (2) The Telephone Company considers a service interrupted when it becomes unusable to the customer because of a failure of a facility component used to furnish service under this Guidebook or in the event that the protective controls applied by the Telephone Company result in the complete loss of service by the customer. An interruption period starts when a customer reports an inoperative service to the Telephone Company and the Telephone Company confirms that continuity has been lost, and ends when the service is operative.
- (4) Service Provisioning
 - (a) The customer provided equipment (CPE) must deliver the data signals for GigaMAN® transport for the subscribed data service.
 - (b) GigaMAN® provides physical layer transport only. The Telephone Company assumes no responsibility for the through transmission of signals generated by the CPE, for the signals by the CPE, or address signaling to the extent the CPE performs addressing. Error detection and correction of data generated by the CPE are the customer's responsibility.

⁽¹⁾ Effective October 2, 2017, GigaMAN Service is no longer available for new circuits. The Telephone Company no longer accepts orders for adds, moves, changes or new term plans for GigaMAN Service, and existing term plans may not be renewed, converted or extended. Following the expiration of a customer's existing GigaMAN term agreement, service will be provided on a month-to-month basis at the applicable monthly extension rates until the service is discontinued.

(N)
|
(N)

(B) Channel Configuration

There are 7 basic rate elements, which apply to GigaMAN[®] service:

(1) Local Distribution Channel (LDC)

Local Distribution Channel is the termination of GigaMAN[®] at a customer- designated premise (node), as described in Part 2, Section 7 of this Guidebook, consisting of the following two elements: (T)
(T)

(a) the termination of the fiber optic facilities at each node in the customer's network;

(b) the fiber optic facility between each node and its serving wire center

(2) Channel Mileage Termination (CMT)

Channel Mileage Termination is the termination of digital transmission facilities (channel mileage) at serving or intermediate wire center(s) associated with two designated premises (nodes), as described in Part 2, Section 7 of this Guidebook. (T)
(T)

(3) Channel Mileage (CM)

Channel mileage includes the interoffice fiber optic facilities that interconnect customer designated premises (node) serving wire centers and/or intermediate wire centers where Channel Mileage Termination charges apply, as described in Part 2, Section 7 of this Guidebook. One channel mileage charge applies per-mile of interoffice transport segments between node serving wire centers, as described in Part 2, Section 7 of this Guidebook. (T)
(T)

(4) Repeater

Repeaters (Circuit Regenerators) provide essential detection and retransmission of GigaMAN[®] signals. Repeaters are provided as required by the Telephone Company when actual fiber facility loss between customer designated premises and/or central office locations exceed design limits. Repeaters will be located exclusively in Telephone Company central offices and are required for each successive transport segment of approximately 21.4 db.

When protection options are ordered, as set forth in Section 7.2.13(K), additional repeaters may be necessary on the protected path as determined by the Telephone Company. The Repeater rate element will be applied to a protected circuit per fiber pair.

(5) Local Channel Diversity

Local Channel Diversity provides for a transmission path between a designated customer premises and the standard service wire center (SWC) that is diverse from the normal/standard transmission path. With this arrangement, one or more local distribution channels will be provisioned over the standard route and one or more local distribution channels will be provisioned over the diverse route. Local channel diversity does not provide for all diversity, it only allows for diversity from the splice point closest to the customer's property line to the SWC. If a customer desires full diversity, arrangements must be made for constructing dual entrance facilities into the customer's premises, at the customer's expense.

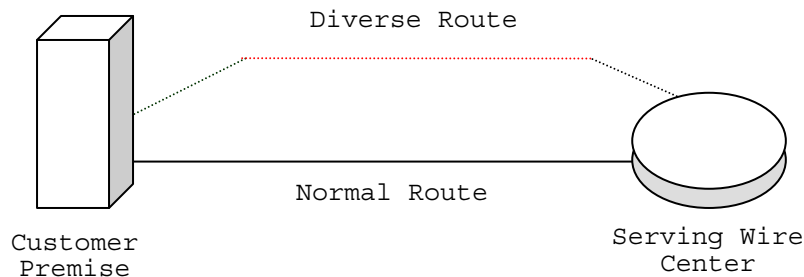

(6) Inter-Wire Center (IWC) Diversity

Inter-Wire Center (IWC) Diversity arrangements presume that each end of a GigaMAN[®] local distribution channel is serviced out of a different serving wire center (SWC). This arrangement provides a transmission path for GigaMAN[®] local distribution channels between the customer's designated SWC and the SWC at the distant end of the circuit over a transmission path that is separate from the standard transmission path between the two wire centers. IWC diversity does not provide for full diversity. It only offers interoffice diversity. If a customer desires full diversity, Alternate Wire Center Diversity must be implemented along with IWC Diversity. Additionally, arrangements must be made for constructing dual entrance facilities at the customer's premises, at the customer's expense.

(a) Inter-Wire Center (IWC) Diversity Mileage Measurement
Mileage measurements for Access Services provisioned via an Inter-Wire Center Diversity, will be based on the special routing; i.e. mileage measurements will be calculated between the Intermediate Serving Wire Centers along the circuit path of the Diversely routed GigaMAN[®] service.

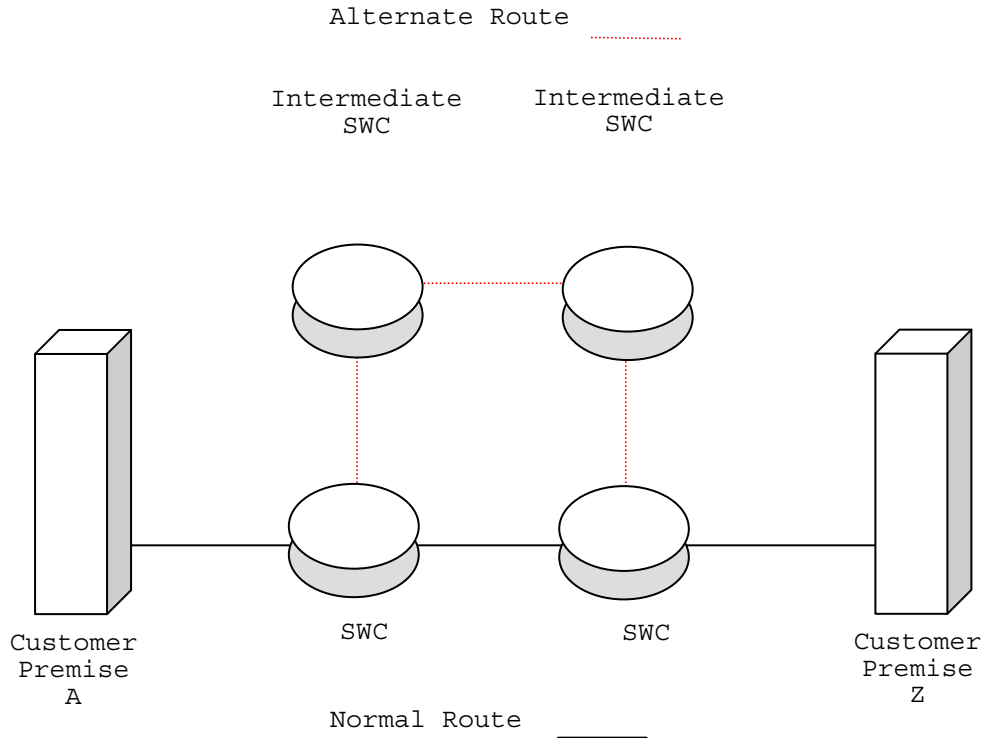

(7) Alternate Wire Center Diversity

Alternate Wire Center Diversity is for the local loop only. It provides a local channel transmission path for GigaMAN[®] service between the customer's designated premises and a wire center that is not the normal (or standard) service wire center. The Telephone Company will choose the alternate wire center closest to the customer's designated premises that is capable of providing GigaMAN[®] service over the alternate route. If a customer desires full diversity, arrangements must be made for constructing dual entrance facilities into the customer's premises, at the customer's expense.

If the circuit routed to the alternate wire center has Interoffice Mileage, measurements will be based on the special routing; i.e., mileage measurements will be made to the alternate wire center rather than the serving wire center from which the customer designated premises would normally obtain dial tone.

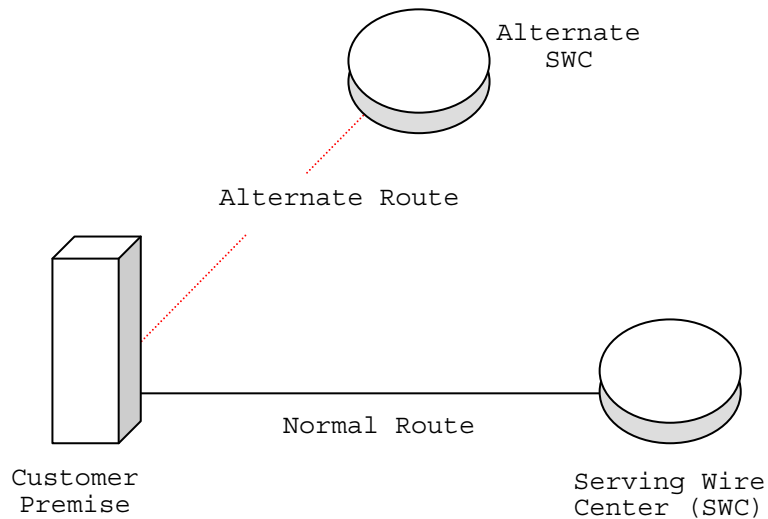

(C) Non-recurring Charges

Non-recurring charges are one-time charges that apply for specific work activity related to the provisioning of GigaMAN® Service, as described in Part 2, Section 7 of this Guidebook.

(D) Recurring Charges

Recurring Charges are rates that apply each month or fraction thereof that the service is provided. Recurring rates apply to 12-, 36-, or 60-month periods under the terms and conditions of the Term Pricing Plan (TPP) as set forth in Section 7.2.1(F).

(E) Monthly Extension Rates

Upon completion of a TPP, a customer's service will automatically convert to the Monthly Extension Rates unless the customer requests a new TPP.

(F) Term Pricing Plan (TPP)

GigaMAN® is available for 12-, 36-, or 60- month periods.⁽¹⁾ (N)
Monthly recurring charges apply for Local Distribution (TMECS), Channel Mileage Termination (CM6), and Channel Mileage (1L5XX) where appropriate.

(1) Renewals⁽¹⁾ (N)

At the end of a TPP period, the customer must select one of the following options within one month prior to the expirations date:

- a. Renew the service for a one, three, or five year TPP as provided in this Guidebook;
- b. Elect to disconnect the service upon expiration of the billing period; or
- c. Continue the service on a monthly basis at the current monthly extension rates.

All services under an existing TPP that are not renewed within the period stated above will revert to Option (1)c above and be billed at the current monthly extension rates.

(2) Conversions⁽¹⁾ (N)

During a customer's TPP term, conversions may be made to a new TPP term of the same or greater length. The expiration date of the new service must be beyond the expiration date of the original TPP term. With the new TPP, the customer incurs no liability for the remaining months on the original TPP.

An Administrative Charge is applicable when customers renew or change the length of the TPP term.

⁽¹⁾ Effective October 2, 2017, GigaMAN Service is no longer available for new circuits. The Telephone Company no longer accepts orders for adds, moves, changes or new term plans for GigaMAN Service, and existing term plans may not be renewed, converted or extended. Following the expiration of a customer's existing GigaMAN term agreement, service will be provided on a month-to-month basis at the applicable monthly extension rates until the service is discontinued.

(N)
|
(N)

(3) Termination Liability

Customers requesting termination of service prior to the expiration date of the TPP term will be liable for a termination charge equal to fifty percent (50%) of the Monthly Recurring Rate for the number of months remaining in the applicable TPP term, which is calculated as follows:

(Monthly Recurring Rate) X (Months Remaining in TPP term) X (50%)
= Termination Liability Charge

Example: A GigaMAN® Customer with a \$6,000.00 monthly rate terminates service after 2 years with 1 year (12 months) remaining in a 3 year TPP. The termination liability charge would be calculated as:

$\$6,000 \times 12 \times .50 = \$36,000.00$ Termination Liability

(G) Moves⁽¹⁾

(N)

Moves involve a change in the physical location of one of the following:

- Service rearrangement;
- Point of Termination at the customer's premises; or
- Customer's premises.

Move charges are dependant upon the type of move requested by the customer.

(1) Service Re-arrangement

Service rearrangements are changes to existing (installed) services, which do not result in either a change in the minimum period requirements, as set forth in Part 2, Section 5 of this Guidebook, or a change in the physical location of the point termination at a customer or customer's end user premises, as described in Part 2, Section 5 of this Guidebook.

⁽¹⁾ Effective October 2, 2017, GigaMAN Service is no longer available for new circuits. The Telephone Company no longer accepts orders for adds, moves, changes or new term plans for GigaMAN Service, and existing term plans may not be renewed, converted or extended. Following the expiration of a customer's existing GigaMAN term agreement, service will be provided on a month-to-month basis at the applicable monthly extension rates until the service is discontinued.

(N)
|
(N)

(2) Moves Within the Same Building

When the move is to a new location within the same building, the Administration charge and Customer Connection charge for the service termination affected will apply. There will be no change in the minimum period requirements, as described in Part 2, Section 7 of this Guidebook.

(T)

(3) Moves to a Different Building

Moves to a different building will be treated as a discontinuance and start of service and all associated nonrecurring charges will apply. New minimum period requirements will be established for the new services. The customer will also remain responsible for satisfying all outstanding minimum period charges for the discontinued service, as described in Part 2, Section 7 of this Guidebook.

(T)

(T)

(4) GigaMAN[®] customers subscribing to three (3) and five (5) year Term Pricing Plans may move one end of the GigaMAN[®] service per the following conditions:

(a) A customer may move one end of the GigaMAN[®] service to a different premises in the same LATA, without incurring early termination liability charges for their existing GigaMAN[®] service, providing the following criteria are met, contingent upon the availability of fiber from premises to premises.

- Customers must have completed at least 15 months (for 3 year term plan), and 18 months (for 5 year term plan) of their existing GigaMAN[®] contracted term plan,
- The customer subscribes to a new term pricing plan period that is greater than the remaining months in the existing term pricing plan,
- Nonrecurring charges will apply where applicable,
- Spare facilities and equipment must be available or special construction charges, as set forth in this Guidebook, may apply.

(T)

The moved service will require a disconnect of the existing GigaMAN[®] service and placement of an order for the new GigaMAN[®] service for same customer of record as disconnected service.

The monthly rates for the new services(s) shall be those rates in effect at the time the new service(s) is being installed requiring a disconnect of the existing GigaMAN[®] service and placement of an order for new GigaMAN[®] service.

- (b) The GigaMAN[®] service installed without protection and customer subsequently request protection options after the GigaMAN[®] order has been completed, and customer premises locations remain the same. This will require a change to the customer premises based Telephone Company equipment. This change will be treated as an upgrade to the GigaMAN[®] service, and a new nonrecurring charge is applicable. This change will require a disconnect of the existing GigaMAN[®] service and placement of an order for the new GigaMAN[®] service for the same customer of record. With this upgrade the customer will experience an out of service condition.
- (c) The GigaMAN[®] service was installed with protection options and the customers subsequently requests a move of the channel termination within the same building afterwards. This request may require a change to the customer premises based Telephone Company equipment which will be determined by the Telephone Company. Nonrecurring charges as set forth in Section 7.5.13 are applicable (one-half the nonrecurring charge for the channel termination). With this upgrade the customer will experience an out of service condition.

(H) Mileage Measurement

The mileage is calculated on the airline distance between the locations involved, i.e., the serving wire centers associated with two customer-designated premises, the serving wire center associated with a customer designated premises and an international boundary point, a serving wire center associated with a customer designated premises and a Telephone Company Hub, a serving wire center associated with a customer designated premises and a WATS Serving Office as described in Part 2, Section 7 of this Guidebook.

(T)

(I) Upgrades

An upgrade is considered an increase in speed or capacity when comparing GigaMAN[®] Service to the new service. Customers will be permitted to upgrade to a higher-speed service provided by the Company, without incurring Termination Charges, given all of the following conditions are met:

- (1) The customer must issue a disconnect order for the existing GigaMAN[®] Service and place a service order for the new higher-speed service at the same locations such that there is no more than 90 days overlap in service.
- (2) The new higher-speed service term must be equal to or greater than the remaining time left on the existing GigaMAN[®] term.
- (3) The existing GigaMAN[®] Service must have been in service for a minimum period of 18 months for a 36-month term or 18 months for a 60-month term. Existing GigaMAN[®] Service with 12-month terms will not be eligible for this upgrade option.

The monthly rates for the new service will be those rates in effect at the time the new service is installed.

(J) Modification of Access Service

The customer may request a modification of its Access Order at anytime prior to notification by Ameritech that service is available for the customer's use. Ameritech will make every effort to accommodate a requested modification when it is able to do so with the normal work force assigned to complete such an order within normal business hours. If the modification cannot be made with the normal work force during normal business hours, Ameritech will notify the customer. If the customer still desires the Access Order Modification, Ameritech will schedule a new service date. All Charges for Access Order modifications will apply on a per occurrence basis as described in Part 2, Section 5 of this Guidebook.

(T)

(K) Optional Features

(1) Protection Options

Protection options are provisioned on the customers GigaMAN[®] service and the customer is not required to purchase a second GigaMAN[®] circuit for protection options. Protection options are applied on a per GigaMAN[®] circuit basis only.

Protection options are available where facilities and/or operating conditions permit. Where facilities and/or operating conditions do not permit, Special Construction charges as set forth in this Guidebook, may apply. Protection options provide additional levels of reliability to GigaMAN[®] service. There are multiple protection options offered. The options do not need to be the same, but both Channel Terminations of the GigaMAN[®] service must include some form of protection for the service to be considered protected.

(T)

The Telephone Company will design the protection optional based upon the configuration of the customers GigaMAN[®] service.

Additional repeaters may be necessary on the protected path as determined by the Telephone Company, as set forth in Part 2, Section 7 of this Guidebook.

(T)

(T)

Protection switching in less than 50 milliseconds will occur on GigaMAN[®] services with Protection options, with the exception of Power Protection which is not switch protected. Protection options are offered with a Service Level Agreements (SLA) that target a service availability of 99.999%.

SLA's are not applicable in the event of cable cut in any unprotected portion of the GigaMAN[®] service fiber path or when customer requested modifications to the service require down time.

GigaMAN[®] Protection Options are offered as follows:

- (a) Equipment Only Protection - per Termination End.
- (b) Equipment Plus Fiber Path Protection
 - (1) Equipment Plus Alternate Wire Center Path Protection - per Terminating End
 - (2) Equipment Plus Channel Termination Path Protection - per Terminating End
 - (3) Inter Wire Center Path Protection - per Interoffice Segment
- (c) Power Protection

(2) Equipment Only Protection

Equipment Only Protection offers one GigaMAN[®] signal routed on two different fiber pairs that co-exist in the same cable and conduit structure that terminate into two distinct and separate network terminating equipment devices at the customer's premises.

All protected configurations have one working and one standby path. In event of a failure of the customer's transmission path, the GigaMAN[®] equipment will switch, within 50 milliseconds of detection, the customer's transmission to a dedicated standby path. In the event of a failure to both fiber transmission paths, an out of service condition will result. This form of protection can only be ordered per channel termination for each protected GigaMAN[®] service, and may also apply to the Inter-Wire center segment if the GigaMAN[®] service is served by more than one serving wire center.

If a customer requests complete protection extending to the SBC serving wire center from their premises location when utilizing Equipment Protection, they must request diverse entrance facilities into their premises at each end from the nearest SBC splice point closest to the customer premises location, this work is subject to special construction charges as set forth in this Guidebook.

(3) Equipment Plus Fiber Path Protection

Equipment Plus Fiber Path Protection offers varying degrees of path protection for each channel termination of the GigaMAN[®] service, plus the inter-wire segment if the service is served by more than one serving wire center, and is offered as follows:

(a) Equipment Plus Alternate Wire Center Path Protection

Equipment Plus Alternate Wire Center Path Protection offers one GigaMAN[®] signal routed over one fiber pair of the protected GigaMAN[®] service from the customer's premises to the customer's normal serving wire center, and a duplicate GigaMAN[®] signal routed over a diversely routed fiber pair to the alternate wire center selected by the Telephone Company.

If any location(s) between the two fiber paths is closer than ten feet, the location(s) will be disclosed to the customer. The customer will determine accept the engineered path or agree to pay special construction charges as set forth in this Guidebook, to provide a completely diverse route where the ten foot allowance is not acceptable to the customer.

Where facilities are not available, the Customer may select Equipment Only Protection for an inter-office segment. This option can be selected for one or both channel terminations of the GigaMAN[®] service. (T)

All protected configurations have one working and one standby path. In the event of a failure of the customer's transmission path, the GigaMAN[®] service will switch to a dedicated standby path within 50 milliseconds of detection. In the event of a failure to both fiber transmission paths, an out of service condition will result. This form of protection can only be ordered per channel termination for each protected GigaMAN[®] service. (T)

If a customer requests complete protection extending to the SBC serving wire center from their premises location when utilizing Equipment Protection Plus Alternate Wire Center Path Protection, they must request diverse entrance facilities into their premises at each end from the nearest SBC splice point closest to the customer premise location. This work is subject to special construction charges as set forth in this Guidebook.

(T)

(b) Equipment Plus Channel Termination Path Protection

Equipment Plus Channel Termination Path Protection offers a duplicate GigaMAN[®] signal routed over two diversely routed fiber paths, to the customer's normal serving wire center.

If any location(s) between two fiber paths is closer than ten feet, the location(s) will be disclosed to the customer. The customer will determine whether to accept the engineered path or agree to pay special construction charges as set forth in this Guidebook, to provide a completely diverse route where the ten foot allowance is not acceptable to the customer.

(T)

All protected configurations have one working and one standby path. In the event of a failure of the customer's transmission path, GigaMAN[®] technology will switch within 50 milliseconds of detection, the customer's transmission to a dedicated standby path. In the event of failure to both fiber transmission to a dedicated standby path. In the event of a failure to both fiber transmission paths, an out to service condition will result.

This form of protection can only be ordered per channel termination for each protected GigaMAN[®] service, from the customers premises location, or from the manhole/splice point nearest the customer premises), to the Utility serving wire center.

If a customer requests complete protection extending to the SBC serving wire center from their premises location when utilizing Equipment Protection Plus Channel Termination Path Protection, they must request diverse entrance facilities into their premises at each end from the nearest SBC splice point closest to the customer premises location. This work is subject to special construction charges as set forth in this Guidebook.

(T)

(c) Inter-Wire Center Path Protection

Inter-Wire Center Path Protection offers a duplicate GigaMAN[®] signal routed over two diversely routed fiber paths, between the two serving wire centers or alternate wire centers. Path protection starts at the nearest manhole outside the Telephone Company serving wire center. Inter-Wire Center Path Protection must be ordered with either Equipment Only, Channel Termination Path Protection or Alternate Wire Center Path Protection.

If any location(s) between the two fiber paths is closer than ten feet, the location(s) will be disclosed to the customer. The customer will determine to accept the engineered path or agree to pay special construction charges as set forth in this Guidebook, to provide a completely diverse route where the ten foot allowance is not acceptable to the customer.

(T)

All protected configurations have one working and one standby path. In the event of a failure of the customer's transmission path, GigaMAN[®] technology will switch, within 50 milliseconds of detection, the customer's transmission to a dedicated standby path. In the event of a failure to both fiber transmission paths, an out of service condition will result.

(d) Power Protection

Power Protection provides GigaMAN[®] customers with battery backup for up to eight (8) hours to maintain GigaMAN[®] equipment in the event of a commercial AC power failure.

Power Protection is offered on a per equipment bay capacity basis, per customer premise, and depending upon the number of GigaMAN[®] services for the GigaMAN[®] customer of record. The Telephone Company will apply the power protection rate elements based upon the circuit capacity, and more than one element may be applicable. The Telephone Company will determine the design and engineering requirements for Power Protection for GigaMAN[®] customers.

Customers in multi-tenant buildings will require separate equipment and bays dedicated to each customer.

The addition of Power Protection to existing GigaMAN[®] service may result in temporary service interruption.

Power Protection is not available for installations using the wall mounted cabinet.

Customers are responsible for providing floor space for power equipment as set forth in Part 2, Section 2 of this Guidebook.

(T)
(T)

(L) Allowance for Service Interruptions

GigaMAN[®] (Not Fully Protected)

(N)

The GigaMAN[®] outage credits listed below are in lieu of, and not in addition to, the outage credit allowances provided for in the General Conditions Section of this Guidebook.

A service is interrupted when it becomes unusable to the customer because of a failure of a facility component used to furnish service under this Guidebook, or in the event that the protective controls applied by the Company result in the complete loss of service by the customer. An interruption period starts when an inoperative service is reported to the Company and the Company confirms that continuity has been lost, and ends when the service is operative.

In case of an interruption to GigaMAN[®] service, allowance for the period of interruption, if not due to the negligence of the customer or the customer's end user, shall be as follows: no credit shall be allowed for an interruption of less than 10 seconds. The customer shall be credited for an interruption of 10 seconds or more as follows: the credit shall be at the rate of 10/8640 of the monthly charges for the service for each period of 5 minutes or major fraction thereof that the interruption continues. The credit allowance(s) for service interruptions shall not exceed 100 percent of the applicable monthly rates.

The Company's failure to provide or maintain services under this Guidebook shall be excused by force majeure events such as, but not limited to, an earthquake, hurricane, flood, fire, storms, tornadoes, explosion, lightning, power surges or failure, fiber cuts, strikes or labor disputes, acts of war, civil disturbances, acts of civil or military authorities or public enemy, governmental orders, civil commotion, criminal actions taken against the Company, acts of God and other circumstances beyond the Company's reasonable control.

(N)

Material previously on this page now appears on Original Page 79.1

GigaMAN[®] (Fully Protected)

A Service Level Agreement (SLA) is offered with fully-protected GigaMAN[®] service, which provides the customer with a performance commitment that includes financial compensation if the service does not perform as described.

An SLA of 99.999 percent Service Availability performance is offered on GigaMAN[®] service with protection (defined as Equipment Plus Path Protection) for every segment of the service.

If this SLA is not met, the customer will be entitled to a credit equal to 100 percent of the monthly rate for the period of the interruption of service affecting that rate element(s), not to exceed the total monthly charges for the services. Only one such credit in a billing period will apply.

The service is considered interrupted when the customer reports a service disruption of greater than ten (10) consecutive seconds to the Telephone Company and the Telephone Company confirms that continuity of its service has been lost.

In order to qualify for this credit, the outage must be determined by the Telephone Company to be in its network and the failure occurred in that part of the service with the protection. SLA adjustments are not available in the event of a cable cut, in any unprotected portion of the GigaMAN[®] service fiber path, or due to customer requested modifications to the service that may require down time.

SLAs are applicable to customers who purchase Equipment Plus Alternate Wire Center Path Protection or Equipment Plus Channel Termination Path Protection on both ends of a GigaMAN[®] service (both channel terminations) as well as Inter-Wire Center Path Protection when applicable. The customer is responsible for notifying the Telephone Company when the service parameter within the calendar month falls below the committed level. The customer must request a service credit adjustment within 25 days after the end of the month when the failure occurred.

Some material previously on this page now appears on Original Page 79.2.

(M) Meet Point Arrangements

In some cases, the Telephone Company and another Incumbent Local Exchange Carrier (ILEC, sometimes also referred to as an Independent Company or ICO) may agree to jointly provide an Ethernet service where such service will be provided in both the Telephone Company's and the other ILEC's serving territories within the same LATA. In such cases, the Telephone Company and the other ILEC may mutually agree to meet at a location (i.e., meet point) within the LATA utilizing facilities suitable for delivery of GigaMAN[®] service. The rates and charges for GigaMAN[®] service are applicable for the Telephone Company provided portion of such service. The Telephone Company is responsible for the ordering, provisioning, billing and maintenance of GigaMAN[®] service up to the meet point. See Part 2, Section 2.7, for regulations applicable to Jointly Provided Access Services.

(N) Migration to AT&T Dedicated Ethernet Service

Customers subscribing to GigaMAN or DecaMAN service may migrate to AT&T Dedicated Ethernet provided by the Telephone Company without incurring termination liability, subject to the following conditions:

- (1) The new AT&T Dedicated Ethernet and the existing GigaMAN or DecaMAN service must be billed to the same customer of record at the same customer locations.
- (2) The customer's existing service must have been in place for at least 12 months.
- (3) The minimum term for the new service must be at least 12 months and must be equal to or greater than the number of months remaining in the customer's existing Term Payment Plan (TPP) term.
- (4) The speed (capacity/bandwidth) of the new service must be equal to or greater than that of the existing service.
- (5) The customer must issue a disconnect order for the replaced GigaMAN or DecaMAN service to be effective within 90 days after the AT&T Dedicated Ethernet installation date. The disconnect order and new orders must be coordinated through the Telephone Company.
- (6) If overlapping service is required, the period will be limited to not more than 90 days and billing will apply to both services during the time both services are available.

(N)

(N)

7.3 Network Channel Interface and Network Channel Codes

The Network Channel Interface (NCI) and the Network Channel codes (NC) and all other associated material which previously appeared in this section are now contained in Ameritech Technical Publication AM-TR-TMO-000080.

7. Special Access Service

7.4 Rate Conditions

7.4.10 Optional Payment Plan (OPP) for Serial Component Video Service (D)
and High Definition Video Transport

(A) General

The Optional Payment Plan is a provision that allows a customer to select Serial Component Video Service (SCVS) over a 12, 24, 36, 48 or 60 month payment period. High Definition Video Transport (HDVT) can be purchased over a 12, 24, 36 or 60 month payment period. Monthly rates for services installed under this Payment Plan will change as Telephone Company initiated rate changes become effective but during the OPP term will not exceed the monthly rate in effect at the beginning of the customer's OPP term. (D)

During the term of the selected OPP, Telephone Company initiated rate changes (increases or decreases) will automatically be applied to the monthly payments for the remaining months of the current OPP term. But in no case will any rate change cause the monthly rate during the OPP term to exceed that in effect at the beginning of the customer's OPP term.

Serial Component Video Service and High Definition Video Transport, rates and charges for which the OPP is available are listed in 7.5 and 21.5.2.5. (D)

Customers subscribing to the OPP will be subject to nonrecurring charges ⁽¹⁾ as specified in 7.5.13 for installation and rearrangements of service covered by the plan. The nonrecurring charges will not be spread over the OPP term. If the customer subscribes to the OPP on an existing service with no other changes, no nonrecurring charges will apply.

(1) For Services ordered under MVP, refer to Section 19.3(E)(5) of Tariff F.C.C. No. 2.

At the expiration of the OPP term and if the customer wishes to continue SCVS or HDVT, the customer may select a new OPP at the prevailing OPP rate. If a customer does not wish to renew the OPP at the expiration of the term, the customer's service will automatically convert to month-to-month, Dedicated Ring Service Monthly Extension rates. (T)

(B) Prepayment of an OPP

A customer may, at any time during an OPP term, elect to prepay the remaining monthly charges for the rest of the term. The prepayment amount will be adjusted for the time value of money. Recurring charges will cease for the rest of the term and start up again at the end of the OPP if service has not been disconnected. If prepayment has been elected and the service is discontinued prior to the end of the OPP term, a credit for the unused portion of the OPP term, adjusted for the time value of money, will be given to the customer. Termination charges will still be applicable. Once a customer selects the prepayment option, the prepaid amount is not adjusted for company initiated rate changes that occur during the period for which the customer has prepaid.

(C) OPP Termination Liabilities

Customer's termination liability for cancellation of service shall be equal to:

- (a) All waived and/or unpaid nonrecurring charges, plus;
- (b) Fifty percent of all recurring charges for the balance of the customer's term.

For example, a customer subscribed to a 60 month OPP term and disconnected service at the end of the 37th month. This customer's termination charge would be: (T)

$$[60 \text{ month OPP rate}] \times [60 \text{ (months in term plan)} - 38 \text{ (full months completed in term plan)}] \times .50 = \text{Termination Charge.} \quad (T)$$

(D)
 |
 (D)

(D) Conversion of service to New OPP or Higher Speed Service (M)

During a customer's OPP term, conversion may be made to a new OPP term of the same of different length or to a higher speed service. If the expiration date for the new service or OPP term is beyond the end of the original OPP term, the remaining OPP charges and any nonrecurring termination charges for the original term will not apply. If no physical changes are made to the service, the Administrative Charge, the Design and Central Office Connection Charge and the Customer Connection Charge will not apply.

(M)

(E) Moves (N)

Early termination liability will not apply when a customer requests moves of SCVS and HDVT service from one premises end point to another end point in a different building within the same LATA provided the following conditions are met.

- (1) The customer must currently subscribe to a 36 or 60 month Optional Payment Plan at the existing location.
- (2) The customer must have completed at least 15 months of the 36 month term or 18 months of the 60 month term.
- (3) For service at the new location, customer subscribes to a new Optional Payment Plan that is equal to or greater than the remaining months in the existing term.
- (4) Nonrecurring installation charges will apply at the new location, where applicable.
- (5) The move from the original location must be completed within thirty (30) days of the original premises disconnect date contingent on availability of fiber from premise to premise.
- (6) Orders from customer to disconnect the existing service and reestablish it at the new location must be placed by customer and received by the Telephone Company at the same time.
- (7) Fiber, equipment and other required facilities must be available at the new location or special construction charges may apply.

(N)

Certain material previously appearing on this page now appears on 2nd Revised Sheet 81.
Certain material now appearing on this page previously appeared on Original Sheet 83.

(F) Upgrades

(N)

An increase in speed, when compared to the existing service, is considered an upgrade. During a customer's OPP term, service upgrades may be made without termination charges. Existing SCVS customers may covert to higher speed HDVT service. Existing analog TV1 video customers may convert to SCVS or the HDVT service.

All of the following conditions must be met to upgrade service without incurring termination charges:

- (1) The customer must issue a disconnect order for the existing SCVS or TV1 Analog service and place a service order for the new higher speed video service at the same locations such that there is no more than 60 days overlap between the two services.
- (2) The same locations must be utilized for the new higher-speed video service.
- (3) The customer must subscribe to a new OPP term that is greater than or equal to the remaining months in the existing term for the lower speed service.
- (4) The existing SCVS or TV1 service must have been in service for a minimum period of 15 months for a 36 month term, or 18 months for a 60 month term.
- (5) Nonrecurring charges will apply where applicable.

(N)

Certain material previously appearing on this page now appears on 1st Revised Sheet 82.

(D)

(D)

7.5 Rates and Charges

(A) Serial Component Video Service (SCVS)

		Recurring Charges					
		Optional Payment Plan					
USOC	Monthly	12 Month	24 Month	36 Month	48 Month	60 Month	
(1) Local Distribution Channel							
(a) SCVS Standard (270 Mbps)							
- Per Point of Termination							
- All States	T7TXX	\$ 435.00	\$ 435.00	\$ 420.00	\$ 410.00	\$ 405.00	\$ 390.00
(b) SCVS Optional (45 Mbps)							
- Per Point of Termination							
- All States	TJ57X	2,000.00	1,900.00	1,825.00	1,750.00	1,700.00	1,650.00
(2) Channel Mileage Termination							
- Per Point of Mileage Termination							
- All States	CM6	45.00	35.00	30.00	25.00	20.00	17.00
(3) Channel Mileage -Per Mile							
- All States	1L5XX	65.00	65.00	60.00	60.00	58.00	55.00
(4) Optional Features and Functions							
-Per Each							
(a) Regenerator							
- All States	V8R	373.00	373.00	369.00	364.00	358.00	352.00

		Optional Payment Plan						
USOC	Monthly	12 Month	24 Month	36 Month	48 Month	60 Month	Nonrecurring Charge ⁽¹⁾	
(b) Optical, Wavelength and Ethernet Handoff Options and Interfaces							(N)	
OC-3 Handoff	VOF3X	\$750.00	\$650.00	\$560.00	\$300.00	\$285.00	\$275.00	\$700.00
OC-12 Handoff	VOF1X	1,675.00	1,450.00	1,250.00	675.00	650.00	625.00	700.00
OC-48 Handoff	VOF4X	1,675.00	1,450.00	1,250.00	675.00	650.00	625.00	700.00 (N)
2.5 Gbps Ethernet/Wavelength Handoff	VOFAX	1,675.00	1,450.00	1,250.00	675.00	650.00	625.00	700.00
10 Gbps Ethernet Handoff	VOFBX	1,675.00	1,450.00	1,250.00	675.00	650.00	625.00	700.00 (N)
SMPTE 310M Digital Interface	V1F3X	400.00	350.00	340.00	315.00	305.00	300.00	500.00
NTSC Analog Interface	V1FNX	200.00	190.00	185.00	180.00	175.00	170.00	500.00

⁽¹⁾ Nonrecurring charge is waived when feature is ordered and installed concurrently with associated Channel Termination.

7.5 Rates and Charges (Cont'd)

(A) Serial Component Video Service (SCVS) (Cont'd)

		Recurring Charges						Nonrecurring Charge
		Optional Payment Plan						
USOC	Monthly	12 Month	24 Month	36 Month	48 Month	60 Month		
(4) Optional Features and Functions (Cont'd)								
(c) Diversity Options:								
-Local Channel Diversity (Per Channel Termination)	CPAMX	\$410.00	\$350.00	\$300.00	\$260.00	\$240.00	\$225.00	N/A (N) (N) N/A
-Alternate Wire Center Diversity (Per Channel Termination)	CPABX	660.00	570.00	490.00	420.00	400.00	360.00	(N) (N) N/A
-Inter-Wire Center Diversity (Per Circuit)	CPAUX	290.00	250.00	210.00	180.00	165.00	150.00	(N)
-Equipment Only Diversity (Per Channel Termination)	CPACX	415.00	370.00	320.00	270.00	255.00	245.00	N/A (N) (N)

7.5 Rates and Charges (Cont'd)

(B) High Definition Video Transport (HDVT)

		Recurring Charges					Nonrecurring Charge ⁽¹⁾
		Optional Payment Plan					
	USOC	Monthly	12 Month	24 Month	36 Month	60 Month	
(1) Channel Termination -per end	TZ4DX	\$750.00	\$700.00	\$625.00	\$585.00	\$525.00	\$1500.00
(2) Interoffice Fixed Mileage	FQY2X	\$50.00	\$48.00	\$48.00	\$45.00	\$43.00	N/A
(3) Variable Mileage -per mile	1A4FX	\$110.00	\$100.00	\$95.00	\$90.00	\$80.00	N/A
(4) Optional Features and Functions -per each							
(a) Regenerator	V8R	\$440.00	\$440.00	\$430.00	\$430.00	\$420.00	N/A
(b) Optical, Wavelength and Ethernet Handoff Options							
-OC-3 Handoff	VOF3X	\$750.00	\$650.00	\$560.00	\$300.00	\$275.00	\$700.00 ^(1,2)
-OC-12 Handoff	VOF1X	\$1,675.00	\$1,450.00	\$1,250.00	\$675.00	\$625.00	\$700.00 ^(1,2)
-OC-48 Handoff	VOF4X	\$1,675.00	\$1,450.00	\$1,250.00	\$675.00	\$625.00	\$700.00 ^(1,2)
-2.5 Gbps Ethernet/Wavelength Handoff	VOFAX	\$1,675.00	\$1,450.00	\$1,250.00	\$675.00	\$625.00	\$700.00 ^(1,2)
-10 Gbps Ethernet Handoff	VOFBX	\$1,675.00	\$1,450.00	\$1,250.00	\$675.00	\$625.00	\$700.00 ^(1,2)
(c) Multi Media Channel ^(1,3)							
-1 Gbps option	HDVM1	\$2,500.00	\$2,000.00	\$2,000.00	\$1,000.00	\$950.00	\$1,500.00
(d) Diversity Options							
-Local Channel Diversity (Per Channel Termination)	CPAMX	\$410.00	\$350.00	\$300.00	\$260.00	\$225.00	N/A
-Alternate Wire Center Diversity (Per Channel Termination)	CPABX	\$660.00	\$570.00	\$490.00	\$420.00	\$360.00	N/A
-Inter-Wire Center Diversity (Per Circuit)	CPAUX	\$290.00	\$250.00	\$210.00	\$180.00	\$150.00	N/A
-Equipment Only Diversity (Per Channel Termination)	CPACX	\$415.00	\$370.00	\$320.00	\$270.00	\$245.00	N/A

(T)

⁽¹⁾ Nonrecurring charge will not apply when the customer subscribes to a 24-Month or longer Optional Payment Plan.

⁽²⁾ Nonrecurring charge is waived when feature is ordered and installed concurrently with associated Channel Termination.

⁽³⁾ Nonrecurring charge is waived when feature is ordered and installed concurrently with associated HDVT Channel Termination.

7.5.10 Optical Carrier Network (OCN) Point-to-Point Service

(A) OC-3/OC-3c Service*

	USOC	12 Month ⁽¹⁾	36 Month ⁽¹⁾	60 Month ^{(1) (2)}	Monthly	(C)
(1) Local Distribution Channel						
- Per Point of Termination Terminating Bit Rate 155.52 Mbps						
- All States	TMECS	\$1,607.00	\$1,368.00	\$1,125.00	\$2,090.00	
(2) Channel Mileage Termination						
- Per Point of Termination						
- Per Point of Mileage Termination 155.52 Mbps						
- All States	CM6	\$469.00	\$399.00	\$375.00	\$853.00	
(3) Channel Mileage						
-Per Mile 155.52 Mbps						
- All States	1L5XX	\$300.00	\$250.00	\$200.00	\$495.00	
(4) Optional Features and Functions						
(a) OC-3 Add/Drop Multiplexing**						
- Per Arrangement	MPECX	\$1,107.00	\$939.00	\$775.00	\$1,295.00	

*Effective January 11, 2002 the 24, and 48 month Optional Payment Plans are being grandfathered for existing customers until their term plan expires, at which time any renewed services or new contracts established on or after January 11, 2002, will no longer be available. Applicable rates for 24 and 48 month Optional Payment Plans can be found in Section 7.5.16.

** Concatenated services not available.

⁽¹⁾ All term plans for OCN Point-to-Point Service which are established or renewed after November 9, 2013, for term lengths which are scheduled to expire at any time after December 31, 2017, will instead expire on December 31, 2017. All such services existing on or after December 31, 2017, will be provided on a month-to-month basis at the applicable, then current month-to-month rates. Notwithstanding anything to the contrary in the previous two sentences, this footnote does not apply to any term plans established or renewed after January 22, 2016.

⁽²⁾ Effective on August 21, 2018, AT&T will no longer offer term plans longer than 36 months, including any renewals, extensions or conversions of existing term commitments. (N)
(N)
(N)

(4) Optional Features and Functions (Cont'd)

	USOC	Monthly	Nonrecurring Charge
(b) Add/Drop Function -Per DS3			
Add or Drop			
-All States	MXJBX	\$125.00	None
-Per DS1			
Add or Drop			
-All States	MXJAX	\$50.00 (I)	None
-Per 1000 Base LX			
- All States	MX4LX	\$500.00	None
(c) Not in Use			
(d) 1+1 Protection			
-Per OC-3/OC-3c			
Customer Premises			
-All States	P8T	\$57.00	None
(e) 1+1 Protection with Cable Survivability ⁽¹⁾			
-Per OC-3/OC-3c			
Customer Premises			
-All States	P3S	\$57.00	\$500.00
(f) 1+1 Protection with Route Survivability ⁽¹⁾			
-All States			
(1) Per OC-3/OC-3c	P8T	Apply Rates and Charges as P8T above plus (2) below	
Customer Premises			
(2) Per Quarter			
Route Mile	S2DXY	\$50.00 (I)	None

⁽¹⁾ Not available for OCN service originating and terminating within a Telephone Company location.

	USOC	Monthly	Nonrecurring Charge
(g) 1+1 Protection with Central Office Survivability* -All States			
(1) Per OC-3 Local Distribution Channel	P8T	Apply Rates and Charges as P8T above plus (2) and (3) below	
(2) Per Quarter Route Mile	S2VXY	\$50.00	None
(3) Channel Mileage and Channel Mileage Terminations	1L5XX CM6	Apply Rates and Charges as 7.5.10A preceding	
(h) Shared Network Arrangement - Processing Charge Per Service Order - All States	NRBOP		30.00
(i) Diversity ⁽¹⁾ -Per Quarter Route Mile -Per OC-3/OC-3c	S2DXY CPAPA	\$50.00 (I) \$200.00	\$0 \$0

*1+1 Protection with Central Office Survivability for OC-3 subscribed to, on or after January 11, 2002, will no longer be available.

⁽¹⁾ The Per Quarter Route Mile is required for one or both ends of the second service when both services terminate at the same customer premises.

(B) Ameritech OC-12/OC-12c Service*

	USOC	12 Month ⁽¹⁾	36 Month ⁽¹⁾	60 Month ⁽¹⁾⁽²⁾	Monthly	(C)
(1) Local Distribution Channel						
-Per Point of Termination Terminating Bit Rate 622.08 Mbps						
-All States	TMECS	\$3,800.00	\$3,400.00	\$2,800.00	\$5,500.00	
(2) Channel Mileage Termination						
- Per Point of Termination						
- Per Point of Mileage Termination 622.08 Mbps						
- All States	CM6	\$665.00	\$595.00	\$560.00	\$2,255.00	
(3) Channel Mileage						
- Per Mile 622.08 Mbps						
- All States	1L5XX	\$475.00	\$425.00	\$400.00	\$644.00	
(4) Optional Features and Functions						
(a) OC-12 Add/Drop Multiplexing**						
- Per Arrangement	MPEDX	\$2,750.00	\$2,340.00	\$1,925.00	\$3,218.00	

* Effective January 11, 2002 the 24, and 48 month Optional Payment Plans are being grandfathered for existing customers until their term plan expires, at which time any renewed services or new contracts established on or after January 11, 2002, will no longer be available. Applicable rates for 24 and 48 month Optional Payment Plans can be found in Section 7.5.16.

** Concatenated services not available.

(1) All term plans for OCN Point-to-Point Service which are established or renewed after November 9, 2013, for term lengths which are scheduled to expire at any time after December 31, 2017, will instead expire on December 31, 2017. All such services existing on or after December 31, 2017, will be provided on a month-to-month basis at the applicable, then current month-to-month rates. Notwithstanding anything to the contrary in the previous two sentences, this footnote does not apply to any term plans established or renewed after January 22, 2016.

(2) Effective on August 21, 2018, AT&T will no longer offer term plans longer than 36 months, including any renewals, extensions or conversions of existing term commitments. (N)
(N)
(N)

	USOC	Monthly	Nonrecurring Charge
(b) Add/Drop Function			
- Per OC-3			
Add or Drop			
- All States	MXJCX	\$150.00	None
- Per DS3			
Add or Drop.			
- All States	MXJBX	\$125.00 (I)	None
- Per 1000 Base LX			
- All States	MX4LX	\$500.00	None
(c) Not in Use			
(d) 1+1 Protection			
- Per OC-12/OC-12c			
Customer			
Premises			
- All States	P8T	\$250.00	None
(e) 1+1 Protection with			
Cable Survivability ⁽¹⁾			
- Per OC-12/OC-12c			
Customer			
Premises			
- All States	P3S	\$250.00	\$600.00
(f) 1+1 Protection with			
Route Survivability ⁽¹⁾			
- All States			
(1) Per OC-12/OC-12c	P8T	Apply Rates and Charges	
Customer		as P8T above plus (2) below	
Premises			
(2) Per Quarter			
Route Mile	S2DXY	\$75.00 (I)	None

⁽¹⁾ Not available for OCN service originating and terminating within a Telephone Company location.

	USOC	Monthly	Nonrecurring Charge
(g) 1+1 Protection with Central Office Survivability* - All States			
(1) Per OC-12 Local Distribution Channel	P8T	Apply Rates and Charges as P8T above plus (2) and (3) below	
(2) Per Quarter Route Mile	S2VXY	\$75.00 (I)	None
(3) Channel Mileage and Channel Mileage Terminations	1L5XX CM6	Apply Rates and Charges as 7.5.10B preceding	
(h) 1+1 Protection with Customer Premises Survivability* - All States			
(1) Per OC-12 Local Distribution Channel	P8T	Apply Rates and Charges as P8T above plus (2) through (5) below	
(2) CPS Mileage - per air mile	1Y6WS	\$220.00	
(3) CPS Termination - per wire center (as required)	CZ42X	100.00	

*1+1 Protection with Central Office Survivability for and/or Customer Premises Survivability for OC-12 subscribed to, on or after January 11, 2002, will no longer be available.

	USOC	Monthly	Nonrecurring Charge
(h) 1+1 Protection with Customer Premises Survivability* (Cont'd) - All States			
(4) CPS OC-12 Regenerator - Each (as required)	RGYDX	\$1,760.00	
(5) CPS Extension - per alternate customer premises	S2VAX	350.00	\$700.00
(i) Shared Network Arrangement - Processing Charge Per Service Order - All States	NRBOP		30.00
(j) Diversity ⁽¹⁾ - Per Quarter Route Mile	S2DXY	\$75.00 (I)	\$0
- Per OC-12/OC-12c	CPAPB	\$300.00	\$0

*1+1 Protection with Customer Premises Survivability for OC-12 subscribed to, on or after January 11, 2002, will no longer be available.

⁽¹⁾ The Per Quarter Route Mile is required for one or both ends of the second service when both services terminate at the same customer premises.

(C)OC-48/OC-48c Service*

	USOC	12 Month ⁽¹⁾	36 Month ⁽¹⁾	60 Month ^{(1) (2)}	Monthly	(C)
(1) Local Distribution Channel						
- Per Point of Termination Terminating Bit Rate 2488.32 Mbps						
-All States	TMECS	\$7,600.00	\$6,600.00	\$5,500.00	\$11,000.00	
(2) Channel Mileage Termination						
- Per Point of Termination						
- Per Point of Mileage Termination 2488.32 Mbps						
- All States	CM6	\$1,497.00	\$1,420.00	\$1,340.00	\$2,200.00	
(3) Channel Mileage						
- Per Mile 2488.32 Mbps						
- All States	1L5XX	\$523.00	\$400.00	\$350.00	\$709.00	
(4) Optional Features and Functions						
(a) OC-48 Add/Drop Multiplexing**						
- Per Arrangement (not to exceed 12 DS3s or equivalent)	MXRFX	\$1,375.00	\$1,170.00	\$965.00	\$1,609.00	

* Effective January 11, 2002 the 24, and 48 month Optional Payment Plans are being grandfathered for existing customers until their term plan expires, at which time any renewed services or new contracts established on or after January 11, 2002, will no longer be available. Applicable rates for 24 and 48 month Optional Payment Plans can be found in Section 7.5.16.

** Concatenated services not available.

(1) All term plans for OCN Point-to-Point Service which are established or renewed after November 9, 2013, for term lengths which are scheduled to expire at any time after December 31, 2017, will instead expire on December 31, 2017. All such services existing on or after December 31, 2017, will be provided on a month-to-month basis at the applicable, then current month-to-month rates. Notwithstanding anything to the contrary in the previous two sentences, this footnote does not apply to any term plans established or renewed after January 22, 2016.

(2) Effective on August 21, 2018, AT&T will no longer offer term plans longer than 36 months, including any renewals, extensions or conversions of existing term commitments. (N)
(N)
(N)

	USOC	Monthly	Nonrecurring Charge
(b) Add/Drop Function			
Per OC-12			
Add or Drop			
- All States	MXJEX	\$375.00	None
Per OC-3			
Add or Drop			
- All States	MXJCX	\$150.00	None
Per DS3			
Add or Drop			
- All States	MXJBX	\$120.00	None
Per 1000 Base LX			
-All States	MX4LX	\$500.00	None
(c) Not in Use			
(d) 1+1 Protection			
-Per OC-48/OC-48c			
Customer			
Premises			
- All States	P8T	\$1,175.00	None
(e) 1+1 Protection with			
Cable Survivability ⁽¹⁾			
-Per OC-48/OC-48c			
Customer			
Premises			
-All States	P3S	\$1,175.00	\$700.00
(f) 1+1 Protection			
with Route			
Survivability ⁽¹⁾			
- All States			
(1) Per OC-48/			
OC-48c	P8T	Apply Rates and Charges	
Customer		as P8T above plus (2) below	
Premises			
(2) Per Quarter			
Route Mile	S2DXY	\$100.00 (I)	None

⁽¹⁾ Not available for OCN service originating and terminating within a Telephone Company location.

	USOC	Monthly	Nonrecurring Charge
(g) 1+1 Protection with Customer Premises Survivability* - All States			
(1) Per OC-48 Local Distribution Channel	P8T	Apply Rates and Charges as P8T above plus (2) through (5) below	
(2) CPS Mileage - per air mile	1Y6WS	\$ 220.00	
(3) CPS Termination - per wire center (as required)	CZ42X	100.00	
(4) CPS OC-48 Regenerator - Each (as required)	RGYDX	2,640.00	
(5) CPS Extension - per alternate customer premises	S2VAX	350.00	\$700.00
(h) Point-to-Point OC-48 Regenerator - Each (as required)	RGY48	\$5,280.00	None
(i) Shared Network Arrangement - Processing Charge Per Service Order - All States	NRBOP		30.00

*1+1 Protection with Customer Premises Survivability for OC-48 subscribed to, on or after January 11, 2002, will no longer be available.

	USOC	Monthly	Nonrecurring Charge
(j) Diversity ⁽¹⁾			
-Per Quarter			
Route Mile	S2DXY	\$ 100.00 (I)	\$0
-Per OC-48/OC-48c	CPAPC	\$ 700.00	\$0

⁽¹⁾ The Per Quarter Route Mile is required for one or both ends of the second service when both services terminate at the same customer premises.

(D) OC-192/OC-192c Service

	USOC	36 Mo. ⁽¹⁾	60 Mo. ⁽¹⁾⁽²⁾	Monthly Extension	(C)
(1) Local Distribution Channel					
- Per Point of Termination Terminating Bit Rate 9953.28 Mbps					
- All States	TMECS	\$20,400.00	\$16,800.00	\$32,340.00	
(2) Channel Mileage Termination					
- Per Point of Mileage Termination 9953.28 Mbps					
- All States	CM6	\$8,000.00	\$6,500.00	\$12,650.00	
(3) Channel Mileage					
- Per Mile 9953.28 Mbps					
- All States	1L5XX	\$520.00	\$440.00	\$715.00	
(4) Optional Features and Functions					
(a) OC-192 Add/Drop Multiplexing*					
- Per Arrangement	MXRGX	\$10,530.00	\$8,685.00	\$15,000.00	
(b) Add/Drop Function Per OC-48 Add or Drop	USOC	Monthly	Nonrecurring Charge		
- All States	MXJFX	\$900.00	None		

*Concatenated services not available.

(1) All term plans for OCN Point-to-Point Service which are established or renewed after November 9, 2013, for term lengths which are scheduled to expire at any time after December 31, 2017, will instead expire on December 31, 2017. All such services existing on or after December 31, 2017, will be provided on a month-to-month basis at the applicable, then current month-to-month rates. Notwithstanding anything to the contrary in the previous two sentences, this footnote does not apply to any term plans established or renewed after January 22, 2016.

(2) Effective on August 21, 2018, AT&T will no longer offer term plans longer than 36 months, including any renewals, extensions or conversions of existing term commitments. (N)
(N)
(N)

	USOC	Monthly	Nonrecurring Charge	
(b) Per OC-12				
Add or Drop				
- All States	MXJEX	\$375.00	None	
Per OC-3				
Add or Drop				
- All States	MXJCX	\$150.00	None	
Per 1000 Base LX				
-All States	MX4LX	\$500.00	None	
(c) Not in Use				(N)
(d) 1+1 Protection				
-Per OC-192/OC-192c				
Customer				(C)
Premises				(C)
- All States	P8T	\$5,400.00	None	
(e) 1+1 Protection				
with Cable				
Survivability ⁽¹⁾				
-Per OC-192/OC-192c				
Customer				(C)
Premises				(C)
- All States	P3S	\$5,400.00	\$800.00	
(f) 1+1 Protection with				
Route Survivability ⁽¹⁾				
- All States				
(1) Per OC-192/				
OC-192c				
Customer	P8T		Apply Rates and Charges	(C)
Premises			as P8T above plus (2) below	(C)
(2) Per Quarter				
Route Mile	S2DXY	\$150.00	None	
(g) Point-to-Point				
OC-192/OC-192c				
Regenerator				
-Each (as required)	RGY	\$11,000.00	None	

⁽¹⁾ Not available for OCN service originating and terminating within a Telephone Company location.

	USOC	Monthly	Nonrecurring Charge
(h) Diversity ⁽¹⁾			
-Per Quarter			
Route Mile	S2DXY	\$150.00	\$0
-Per OC-192/OC-192c	CPAPD	\$1200.00	\$0

⁽¹⁾ The Per Quarter Route Mile is required for one or both ends of the second service when both services terminate at the same customer premises.

7.5.110C-3, OC-12, OC-48 and OC-192 Dedicated Ring

(A)Node		36	60	Monthly	(C)
Description	USOC	Months ⁽³⁾	Months ^{(3) (4)}	Extension	
Per Node:					
OC-3					
- Customer Premises					
First	FP5CX	\$1,650.00	\$1,200.00	\$2,120.00	
First Re-Map ⁽²⁾	RN8CX	1,770.00	1,415.00	2,120.00	
Additional	FP5CA	1,000.00	800.00	1,200.00	
Additional Re-Map ⁽²⁾	RN8CA	1,000.00	800.00	1,200.00	
- Central Office	FC5CX	1,000.00	800.00	1,200.00	
OC-12					
- Customer Premises					
First	FP5DX	3,850.00	3,000.00	4,620.00	
First Re-Map ⁽²⁾	RN8DX	3,850.00	3,080.00	4,620.00	
Additional	FP5DA	2,620.00	2,000.00	3,140.00	
Additional Re-Map ⁽²⁾	RN8DA	2,620.00	2,095.00	3,140.00	
- Central Office	FC5DX	2,620.00	1,900.00	3,140.00	
Direct Drop ⁽¹⁾					
- Customer Premises					
First	L8NDX	3,750.00	2,980.00	4,470.00	
First Re-Map ⁽²⁾	RL8DX	3,750.00	2,980.00	4,470.00	
Additional	L8NDA	2,520.00	1,995.00	2,990.00	
Additional Re-Map ⁽²⁾	RL8DA	2,520.00	1,995.00	2,990.00	
- Central Office	L9NDX	2,520.00	1,995.00	2,990.00	
OC-48					
- Customer Premises					
First	FP5EX	5,500.00	4,190.00	6,500.00	
First Re-Map ⁽²⁾	RN8EX	5,890.00	4,715.00	7,070.00	
Additional	FP5EA	5,240.00	4,190.00	6,280.00	
Additional Re-Map ⁽²⁾	RN8EA	5,240.00	4,190.00	6,280.00	
Plus ⁽¹⁾	FP5SX	5,240.00	4,000.00	6,280.00	
Plus Re-Map ⁽¹⁾	RN8SX	5,240.00	4,190.00	6,280.00	
- Central Office	FC5EX	4,500.00	3,700.00	6,280.00	
- Central Office Plus ⁽¹⁾	FC5SX	4,870.00	3,900.00	5,850.00	
OC-192					
- Customer Premises					
First	GP5AX	19,800.00	16,000.00	33,000.00	
First Re-Map ⁽²⁾	RNFAX	19,800.00	16,000.00	33,000.00	
Additional	GP5AA	17,800.00	14,200.00	29,475.00	
Additional Re-Map ⁽²⁾	RNFAX	17,800.00	14,200.00	29,475.00	
- Central Office	GC5AX	17,800.00	14,200.00	29,475.00	

(1) Effective 03/18/06, the OC-48 "Plus" and Direct Drop Node features will no longer be available to new customers. There will be no change to existing customers.

(2) Effective August 1, 2013, availability of Re-Map nodes is limited to Re-Map nodes that are in service or have been ordered prior to August 1, 2013.

(3) All term plans for OC-3, OC-12, OC-48 and OC-192 Dedicated Ring service which are established or renewed after November 9, 2013, for term lengths which are scheduled to expire at any time after February 1, 2019, will instead expire on February 1, 2019. All such services existing on or after February 1, 2019, will be provided on a month-to-month basis at the applicable, then current month-to-month rates. Notwithstanding anything to the contrary in the previous two sentences, this footnote does not apply to any term plans established or renewed after July 15, 2017.

(4) Effective on August 21, 2018, AT&T will no longer offer term plans longer than 36 months, including any renewals, extensions or conversions of existing term commitments. (N)

Description	USOC	36 Months ⁽³⁾	60 Months ^{(3) (4)}	Monthly Extension	(C)
Per node:					
Flex-Ring					
Customer Premise node for 2nd ring double on existing					
OC-12	GP5FX	2,200.00	1,800.00	2,900.00	
OC-48	GP5GX	3,900.00	3,000.00	4,500.00	
Central Office node for 2nd ring double on existing					
OC-12	GC5FX	1,850.00	1,500.00	2,200.00	
OC-48	GC5GX	3,500.00	2,800.00	4,100.00	

Description	USOC			Nonrecurring Charge
Nonrecurring charges for subsequent installation - Per Node				
Customer Premises	NRBS7			\$400.00
Customer Premises Re-Map ⁽²⁾	NRBS7			400.00
Central Office	NRBSV			325.00

(B) OC-48 Add/Drop Capability

Description	USOC	36 Months ⁽³⁾	60 Months ^{(3) (4)}	Monthly Extension	(C)
Per Arrangement	MPEFX	\$700.00	\$500.00	\$1,450.00	
Re-Map ⁽²⁾	M8RFX	1,170.00	965.00	1,450.00	
Plus ⁽¹⁾	MPEPX	800.00	500.00	1,290.00	
Re-Map ⁽²⁾	M8RPX	1,040.00	859.00	1,290.00	

Description	USOC			Nonrecurring Charge
Nonrecurring charges for subsequent installation - Per Arrangement				
	NRBS8			\$490.00

⁽¹⁾ Effective 03/18/06, the OC-48 "Plus" and Direct Drop Node features will no longer be available to new customers. There will be no change to existing customers.

⁽²⁾ Effective August 1, 2013, availability of Re-Map nodes is limited to Re-Map nodes that are in service or have been ordered prior to August 1, 2013.

⁽³⁾ All term plans for OC-3, OC-12, OC-48 and OC-192 Dedicated Ring service which are established or renewed after November 9, 2013, for term lengths which are scheduled to expire at any time after February 1, 2019, will instead expire on February 1, 2019. All such services existing on or after February 1, 2019, will be provided on a month-to-month basis at the applicable, then current month-to-month rates. Notwithstanding anything to the contrary in the previous two sentences, this footnote does not apply to any term plans established or renewed after July 15, 2017.

⁽⁴⁾ Effective on August 21, 2018, AT&T will no longer offer term plans longer than 36 months, including any renewals, extensions or conversions of existing term commitments.

(N)
(N)

(C) OC-192 Add/Drop Capability

Description	USOC	36 Months ⁽⁷⁾	60 Months ^{(7) (8)}	Monthly Extension	(C)
- per node ⁽²⁾ (not to exceed any configurable combination of ports beyond 192 STS-1 equivalents)	MXRGX	\$4,500.00	\$3,600.00	\$7,000.00	
- Re-Map ^{(5) (6)}	M8RGX	\$4,500.00	\$3,600.00	\$7,000.00	

(D) Ports

Description	USOC	36 Months	60 Months ⁽⁸⁾	Monthly Extension	(C)
- Per Port (excluding Re-Map)					
DS1 at OC-3 Node	SPRAX	\$ 30.00	\$ 25.00	\$ 65.00	
DS3 at OC3 Node	SPRBX	110.00	100.00	140.00	
EC-1at OC-3 Node	S9NSX	120.00	110.00	150.00	
OC-3 at OC-3 Node	S9T1X	350.00	300.00	550.00	
100 Mbps Ethernet (STS-1) at OC-3 node*	S9TAX	145.00	130.00	225.00	
DS3 at OC-12 (DDN) ⁽⁴⁾	SPRMX	110.00	100.00	140.00	
DS3 at OC-12 Node	SPRCX	110.00	100.00	140.00	
EC-1at OC-12 Node	S9NUX	120.00	110.00	150.00	
OC-3, OC-3c at OC-12 Node	SPREX	135.00	120.00	200.00	
DS1 at OC-12 (DDN) ^{(1) (4)}	SPRNX	30.00	25.00	65.00	
DS1 at OC-12 Node ^{(1) (3)}	SPRGX	30.00	25.00	65.00	
OC-12 at OC-12 Node	S9T2X	850.00	725.00	1050.00	
100 Mbps Ethernet (STS-1) at OC-12 node*	S9TBX	145.00	130.00	225.00	
100 Mbps Ethernet (STS-3c) at OC-12 node*	S9TCX	180.00	160.00	280.00	
1 Gbps Ethernet (STS-1) at OC-12 node*	S9TDX	250.00	200.00	350.00	
1 Gbps Ethernet (STS-3c) at OC-12 node*	S9TEX	250.00	200.00	350.00	

- ⁽¹⁾ Optical-to-Electrical DS1 Add/Drop Capability as described in 7.2.11(B) (5) is needed along with an OC-3 port unless the customer has chosen an OC-12 DDN.
 - ⁽²⁾ The OC-192 Add/Drop Capability charge is applied to all nodes, excluding regenerators and CO nodes without drop ports.
 - ⁽³⁾ The Optical-to-Electrical DS1 Add/Drop Capability will be charged when the 85th DS1 port is applied per OC-12 node.
 - ⁽⁴⁾ Effective 03/18/06, the Direct Drop Node (DDN) feature will no longer be available to new customers. There will be no change to existing customers.
 - ⁽⁵⁾ Available for rings established on or after 10/17/06.
 - ⁽⁶⁾ Effective August 1, 2013, availability of Re-Map nodes is limited to Re-Map nodes that are in service or have been ordered prior to August 1, 2013.
 - ⁽⁷⁾ All term plans for OC-3, OC-12, OC-48 and OC-192 Dedicated Ring service which are established or renewed after November 9, 2013, for term lengths which are scheduled to expire at any time after February 1, 2019, will instead expire on February 1, 2019. All such services existing on or after February 1, 2019, will be provided on a month-to-month basis at the applicable, then current month-to-month rates. Notwithstanding anything to the contrary in the previous two sentences, this footnote does not apply to any term plans established or renewed after July 15, 2017.
 - ⁽⁸⁾ Effective on August 21, 2018, AT&T will no longer offer term plans longer than 36 months, including any renewals, extensions or conversions of existing term commitments. (N)
- * Effective September 5, 2003, new orders for Dedicated Ring Service with the EoS enhancement will be served by different equipment. Disconnect of the existing Dedicated Ring Service and placement of an order for new Dedicated Ring Service with the EoS enhancement is required. Refer to Section 7.2.11(B) (9) for details. (N)

Description	USOC	36 Months ⁽²⁾	60 Months ^{(2) (3)}	Monthly Extension	(C)
- Per Port (excluding Re-Map) (Cont'd)					
OC-12, OC-12c at OC-48 Node	SPRHX	\$ 325.00	\$ 300.00	\$ 475.00	
OC-3, OC-3c at OC-48 Node	SPRJX	135.00	120.00	200.00	
DS3 at OC-48 Node	SPRKX	110.00	100.00	150.00	
EC-1at OC-48 Node	S9NVX	120.00	110.00	150.00	
DS1 at OC-48 Node ⁽¹⁾	SPRLX	30.00	25.00	65.00	
OC-48 at OC-48 Node	S9T3X	1900.00	1650.00	2850.00	
100 Mbps Ethernet (STS-1) at OC-48 node*	S9TGX	145.00	130.00	225.00	
100 Mbps Ethernet (STS-3c) at OC-48 node*	S9THX	180.00	160.00	280.00	
1 Gbps Ethernet (STS-1) at OC-48 node*	S9TJX	250.00	200.00	350.00	
1 Gbps Ethernet (STS-3c) at OC-48 node*	S9TKX	250.00	200.00	350.00	
1 Gbps Ethernet (STS-12c) at OC-48 node*	S9TLX	600.00	500.00	875.00	
1 Gbps Ethernet (STS-24c) at OC-48 node*	S9TMX	900.00	850.00	1,500.00	
OC-3, OC-3c at OC-192 Node	S9NEX	135.00	120.00	200.00	
OC-12, OC-12c at OC-192 Node	S9NGX	325.00	300.00	475.00	
OC-48, OC-48c at OC-192 Node	S9NJX	825.00	700.00	1,425.00	
OC-192 at OC192 Node	S9T4X	3300.00	3000.00	5700.00	
DS1 at OC-192 Node	S9QWX	50.00	45.00	65.00	
DS3 at OC-192 Node	S9QGX	110.00	100.00	140.00	
EC-1 at OC-192 Node	S9TZX	120.00	110.00	150.00	
DS3 w/Transmux	S4NGX	250.00	200.00	300.00	
100 Mbps Ethernet (STS-1) at OC-192 node*	S9TNX	145.00	130.00	225.00	
100 Mbps Ethernet (STS-3c) at OC-192 node*	S9TOX	180.00	160.00	280.00	
1 Gbps Ethernet (STS-1) at OC-192 node*	S9TPX	250.00	200.00	350.00	
1 Gbps Ethernet (STS-3c) at OC-192 node*	S9TQX	250.00	200.00	350.00	
1 Gbps Ethernet (STS-12c) at OC-192 node *	S9TRX	600.00	500.00	875.00	
1 Gbps Ethernet (STS-24c) at OC-192 node *	S9TSX	900.00	850.00	1,500.00	

⁽¹⁾ Optical-to-Electrical DS1 add/drop capability as described in 7.2.11(B)(5) is needed along with an OC-3 port unless the customer has chosen an OC-12 DDN.

⁽²⁾ All term plans for OC-3, OC-12, OC-48 and OC-192 Dedicated Ring service which are established or renewed after November 9, 2013, for term lengths which are scheduled to expire at any time after February 1, 2019, will instead expire on February 1, 2019. All such services existing on or after February 1, 2019, will be provided on a month-to-month basis at the applicable, then current month-to-month rates. Notwithstanding anything to the contrary in the previous two sentences, this footnote does not apply to any term plans established or renewed after July 15, 2017.

⁽³⁾ Effective on August 21, 2018, AT&T will no longer offer term plans longer than 36 months, including any renewals, extensions or conversions of existing term commitments. (N)
(N)

* Effective September 5, 2003, new orders for Dedicated Ring Service with the EoS enhancement will be served by different equipment. Disconnect of the existing Dedicated Ring Service and placement of an order for new Dedicated Ring Service with the EoS enhancement is required. Refer to Section 7.2.11(B)(9) for details.

Description	USOC	36 Months ⁽⁶⁾	60 Months ^{(6) (7)}	Monthly Extension	(C)
EoS Ports					
Virtual Concatenation (VCAT) ⁽¹⁾					
- per multiplexing function					
10/100 BaseT Ethernet Port	S5P1X	250.00	180.00	350.00	
Bandwidth options for port ^{(2) (4) (5)}					
VT1.5-1v (1.6 Mbps)					
VT1.5-2v (3.2 Mbps)					
VT1.5-3v (4.8 Mbps)					
VT1.5-4v (6.4 Mbps)					
VT1.5-5v (8.0 Mbps)					
VT1.5-6v (9.6 Mbps)					
VT1.5-7v (11.2 Mbps)					
VT1.5-8v (12.4 Mbps)					
VT1.5-10v (16.0 Mbps)					
VT1.5-13v (20.8 Mbps)					
STS-1-1v (48.38 Mbps)					
STS-1-2v (96.77 Mbps)					
1000 Base SX Ethernet Port	S5P2X	425.00	350.00	500.00	
1000 Base LX Ethernet Port	S5P3X	425.00	350.00	500.00	
Bandwidth options for port ^{(3) (4) (5)}					
STS-1-1v (48.38 Mbps)					
STS-1-2v (96.77 Mbps)					
STS-1-3v (145.15 Mbps)					
STS-1-4v (193.54 Mbps)					
STS-1-5v (241.92 Mbps)					
STS-1-6v (290.30 Mbps)					
STS-1-9v (435.46 Mbps)					
STS-1-12v (580.61 Mbps)					
STS-1-21v (1016.06 Mbps)					
STS-3c-1v (149.76 Mbps)					
STS-3c-2v (299.52 Mbps)					
STS-3c-3v (449.28 Mbps)					
STS-3c-4v (599.04 Mbps)					
STS-3c-7v (1048.32 Mbps)					

⁽¹⁾ Nonrecurring charges apply to EoS Ports, Virtual Concatenation (VCAT). See EoS Port charges in Section 7.5.11(D), for applicable nonrecurring charges.

⁽²⁾ Actual payload capacity for selected bandwidth.

⁽³⁾ Actual Payload capacity for selected bandwidth applies to both SX and LX.

⁽⁴⁾ Only Single-Mode Fiber is available in the Central Office.

⁽⁵⁾ The EoS line rates defined herein are based on the theoretical SONET payload line rates as per GR-253-CORE, Issue 4. These values are not representative of the true Ethernet transport capacity of the EoS circuit.

⁽⁶⁾ All term plans for OC-3, OC-12, OC-48 and OC-192 Dedicated Ring service which are established or renewed after November 9, 2013, for term lengths which are scheduled to expire at any time after February 1, 2019, will instead expire on February 1, 2019. All such services existing on or after February 1, 2019, will be provided on a month-to-month basis at the applicable, then current month-to-month rates. Notwithstanding anything to the contrary in the previous two sentences, this footnote does not apply to any term plans established or renewed after July 15, 2017.

⁽⁷⁾ Effective on August 21, 2018, AT&T will no longer offer term plans longer than 36 months, including any renewals, extensions or conversions of existing term commitments. (N)
(N)

Description	USOC	36 Months ⁽⁴⁾	60 Months ⁽⁴⁾	Monthly Extension
- Per Port - Re-Map ⁽³⁾				
- Per DS1 Re-Map Block (consists of 28 DS1 ports) at				
OC-3 Ring	P8RAX	1,400.00	1,260.00	1,820.00
OC-12 Ring	P8RGX	1,400.00	1,260.00	1,820.00
OC-12 DDN Ring ⁽¹⁾	P8RNX	1,400.00	1,260.00	1,820.00
OC-48 Ring	P8RLX	1,400.00	1,260.00	1,820.00
OC-192 Ring	RN76X	1,400.00	1,260.00	1,820.00
- Per DS3 Re-Map Port at				
OC-3 Ring	P8RBX	120.00	110.00	150.00
OC-12 DDN Ring ⁽¹⁾	P8RMX	120.00	110.00	150.00
OC-192 Ring	RN71X	120.00	110.00	150.00
- Per DS3 Re-Map Block (consists of 3 DS3 ports) at				
OC-12 Ring	P8RCX	360.00	330.00	450.00
OC-48 Ring	P8RKX	360.00	330.00	450.00
OC-192 Ring	RN77X	360.00	330.00	400.00
- Per DS3 Transmux Re-Map ⁽²⁾				
	RN7TX	250.00	200.00	300.00
- Per EC-1 Re-Map Port at				
OC-3 Ring	S9N6X	120.00	110.00	150.00
OC-12 Ring	S9N8X	120.00	110.00	150.00
OC-48 Ring	S9N9X	120.00	110.00	150.00
OC-192 Ring	S4NMX	120.00	110.00	150.00
- Per OC-3, OC-3c Re-Map Port at				
OC-12 Ring	P8REX	150.00	135.00	190.00
OC-48 Ring	P8RJX	150.00	135.00	190.00
OC-192 Ring	RN72X	150.00	135.00	190.00
- Per OC-12, OC-12c Re-Map Port at				
OC-48 Ring	P8RHX	375.00	360.00	475.00
OC-192 Ring	RN73X	375.00	360.00	475.00
- Per OC-48, OC-48c Re-Map Port at				
OC-192 Ring	RN74X	825.00	700.00	1425.00

⁽¹⁾ Effective 03/18/06, the Direct Drop Node feature will no longer be available to new customers. There will be no change to existing customers.

⁽²⁾ Available for rings established on or after 10/17/06.

⁽³⁾ Effective August 1, 2013, availability of Re-Map nodes is limited to Re-Map nodes that are in service or have been ordered prior to August 1, 2013.

⁽⁴⁾ All term plans for OC-3, OC-12, OC-48 and OC-192 Dedicated Ring service which are established or renewed after November 9, 2013, for term lengths which are scheduled to expire at any time after February 1, 2019, will instead expire on February 1, 2019. All such services existing on or after February 1, 2019, will be provided on a month-to-month basis at the applicable, then current month-to-month rates. Notwithstanding anything to the contrary in the previous two sentences, this footnote does not apply to any term plans established or renewed after July 15, 2017.

(N)
(N)
(N)

<u>Description</u>	<u>USOC</u>	<u>Nonrecurring Charge</u>
Nonrecurring charges for subsequent Installation		
-Per port type		
OC-192	NRBN2	\$850.00
OC-48 or OC-48c	NRBN9	425.00
OC-12 or OC-12c	NRBSZ	400.00
OC-3 or OC-3c	NRBSW	400.00
EC-1	NRBSX	385.00
DS3	NRBSX	385.00
DS3 w/Transmux	NRBSX	385.00
DS1	NRBSY	350.00
100 Mbps Ethernet STS-1*	NRM63	385.00
100 Mbps Ethernet STS-3c*	NRM64	385.00
1 Gbps Ethernet STS-1*	NRM65	425.00
1 Gbps Ethernet STS-3c*	NRM66	425.00
1 Gbps Ethernet STS-12c*	NRM67	425.00
1 Gbps Ethernet STS-24c*	NRM68	425.00
10/100 BaseT Ethernet Port	NRM63	385.00
1000 BaseLX Ethernet Port	NRM65	425.00
1000 BaseSX Ethernet Port	NRM66	425.00

- * Effective September 5, 2003, new orders for Dedicated Ring Service with the EOS enhancement will be served by different equipment. Disconnect of the existing Dedicated Ring Service and placement of an order for new Dedicated Ring Service with the EOS enhancement is required. Refer to Section 7.2.11(B) (9) for details.

(E) Mileage

Description	USOC	36 Months ⁽⁵⁾	60 Months ^{(5) (6)}	Monthly Extension (C)
Per mile between nodes by ring type				
OC-3	1L5XX	\$260.00	\$200.00	\$330.00
OC-12	1L5XX	260.00	200.00	330.00
OC-48	1L5XX	260.00	200.00	330.00
OC-192	1L5XX	260.00	200.00	330.00

(F) Optical to Electrical Add/Drop Capability

Description	USOC	36 Months ⁽⁵⁾	60 Months ^{(5) (6)}	Monthly Extension (C)
Per Arrangement ⁽¹⁾				
- (per OC-192 node) not to exceed any configurable combination of ports beyond 192 STS-1 equivalents	MXJGX	2,500.00	2,000.00	3,500.00
- Re-Map ^{(2) (4)} Per Optical to Electrical DS-3 Add/Drop Capability	M6JGX	2,500.00	2,000.00	3,500.00
Per OC-3 to DS1 Add/Drop ⁽³⁾	MXJDX	875.00	700.00	1,050.00
Re-Map ⁽⁴⁾ Per OC-3 to DS1 Add/Drop ⁽³⁾	M8RDX	875.00	700.00	1,050.00

Description	USOC	Nonrecurring Charge
Nonrecurring charges for subsequent installation		
- Per OC-3 to DS1 Add/Drop	NRBS6	\$490.00

⁽¹⁾ When electrical drops are required, the OC-192 Optical-to-Electrical Add/Drop Capability charge is applied in addition to the Add/Drop Capability charge set forth in Section 7.5.11(C).

⁽²⁾ Available for rings established on or after 10/17/06.

⁽³⁾ An OC-3 port charge is needed with each Optical-to-Electrical Add/Drop Capability - Per OC-3 to DS-1 Add/Drop.

⁽⁴⁾ Effective August 1, 2013, availability of Re-Map nodes is limited to Re-Map nodes that are in service or have been ordered prior to August 1, 2013.

⁽⁵⁾ All term plans for OC-3, OC-12, OC-48 and OC-192 Dedicated Ring service which are established or renewed after November 9, 2013, for term lengths which are scheduled to expire at any time after February 1, 2019, will instead expire on February 1, 2019. All such services existing on or after February 1, 2019, will be provided on a month-to-month basis at the applicable, then current month-to-month rates. Notwithstanding anything to the contrary in the previous two sentences, this footnote does not apply to any term plans established or renewed after July 15, 2017.

⁽⁶⁾ Effective on August 21, 2018, AT&T will no longer offer term plans longer than 36 months, including any renewals, extensions or conversions of existing term commitments. (N)

(G) Dedicated Ring Regenerator

Description	USOC	36 Months ⁽¹⁾	60 Months ^{(1) (2)}	Monthly Extension	(C)
OC-3 Each (as required)	RGY	\$1,000.00	\$ 800.00	\$1,200.00	
OC-12 Each (as required)	RGY	2,620.00	2,095.00	3,140.00	
OC-48 Each (as required)	RGY	3,275.00	2,475.00	3,930.00	
OC-192 Each (as required)	RGY	9,250.00	7,400.00	13,875.00	

Description	USOC	Nonrecurring Charge
Nonrecurring charges for subsequent installation of Regenerator - Each (as required)	NRBS5	\$270.00

(H) Shared Network Arrangement

Processing Charge Per Service Order - All States	NRBOP	30.00
---	-------	-------

⁽¹⁾ All term plans for OC-3, OC-12, OC-48 and OC-192 Dedicated Ring service which are established or renewed after November 9, 2013, for term lengths which are scheduled to expire at any time after February 1, 2019, will instead expire on February 1, 2019. All such services existing on or after February 1, 2019, will be provided on a month-to-month basis at the applicable, then current month-to-month rates. Notwithstanding anything to the contrary in the previous two sentences, this footnote does not apply to any term plans established or renewed after July 15, 2017.

⁽²⁾ Effective on August 21, 2018, AT&T will no longer offer term plans longer than 36 months, including any renewals, extensions or conversions of existing term commitments. (N)
(N)

7.5.13 Gigabit Ethernet Metropolitan Area Network (GigaMAN®)

(A) GigaMAN® Service⁽¹⁾

(N)

	USOC	Monthly Extension	Recurring Charges Term Pricing Plan			
			12 Mo.	36 Mo.	60 Mo.	
(1) Local Distribution Channel - Per Point of Termination Terminating Bit Rate 1 Gbps - All States	TMECS	\$3,800.00	\$3,300.00	\$2,850.00	\$2,500.00	
(2) Channel Mileage Termination - Per Point of Termination - Per Point of Mileage Termination 1 Gbps - All States	CM6	\$125.00	\$125.00	\$100.00	\$50.00	
(3) Channel Mileage - Per Mile 1 Gbps -All States	1L5XX	\$ 125.00	\$ 125.00	\$ 100.00	\$ 75.00	
(4) Repeater -each	VU4	\$2,500.00	\$2,400.00	\$1,150.00	\$850.00	
(5) Diversity Options						
			Term Pricing Plan			
	USOC	Monthly Extension	12 Mo.	36 Mo.	60 Mo.	NRC
(a) <u>Local Channel</u> <u>Diversity</u> - Per Channel Terminating Bit Rate 1 Gbps - All States	CPALX	\$750.00	\$750.00	\$750.00	\$750.00	0.00

⁽¹⁾ Effective October 2, 2017, GigaMAN Service is no longer available for new circuits. The Telephone Company no longer accepts orders for adds, moves, changes or new term plans for GigaMAN Service, and existing term plans may not be renewed, converted or extended. Following the expiration of a customer's existing GigaMAN term agreement, service will be provided on a month-to-month basis at the applicable monthly extension rates until the service is discontinued.

(N)

(N)

	USOC	Monthly Extension	Recurring Charges Term Pricing Plan			NRC	
			12 Mo.	36 Mo.	60 Mo.		
(5) Diversity Options (Cont'd)							
(b) <u>Inter-Wire Diversity</u> -Per Circuit Terminating Bit Rate 1 Gbps -All States	CPATX	\$500.00	\$500.00	\$500.00	\$500.00	0.00	(C)
(c) <u>Alternate Wire Center Diversity</u> -Per Channel Terminating Bit Rate 1 Gbps -All States	CPAAX	\$1,200.00	\$1,200.00	\$1,200.00	\$1,200.00	0.00	
(6) Protection -per GigaMAN [®] service arranged							
(a) <u>Equipment Only Protection</u> -Per Terminating End	CPAEX	1,500.00	\$1,375.00	1,050.00	900.00	625.00	
(b) <u>Equipment Plus Alternate Wire Center Path Protection</u> -Per Terminating End	CPAFX	2,460.00	2,050.00	1,600.00	1,400.00	1,400.00	
(c) <u>Equipment Plus Channel Termination (Local Channel) Path Protection</u> -Per Terminating End	CPAGX	2,190.00	1,825.00	1,425.00	1,225.00	1,225.00	

	USOC	Monthly Extension	Recurring Charges Term Pricing Plan			NRC
			12 Mo.	36 Mo.	60 Mo.	
(6) Protection -per GigaMAN [®] service arranged (Cont'd)						
(d) <u>Inter-Wire Center Path Protection -Per Circuit</u>	CPAHX	475.00	375.00	150.00	100.00	625.00
(e) <u>Power Protection</u> ⁽¹⁾	VBBGX	700.00	625.00	480.00	435.00	475.00

⁽¹⁾Power Protection rate elements are applicable as set forth in Section 7.2.13(K) (d).

(T)
(D)

7.5.15 Installation and Rearrangement Charges

All States		Administrative Charge, per order	Design and Central Office Connection Charge, per circuit	Customer Connection Charge, per termination	
USOC	ORCMX	NRBCL	NRBBL		
Serial Component Video Service	50.00	440.00	140.00		
High Definition Video Transport	50.00	440.00	140.00		(N) (N)
OC-3 Service - 155.52 Mbps	60.00	375.00	450.00		
OC-12 Service - 622.08 Mbps	60.00	375.00	450.00		
OC-48 Service - 2488.32 Mbps	60.00	500.00	600.00		
OC-192/OC-192c Service - 9953.28 Mbps	60.00	2,250.00	600.00		
Ethernet 100 Base	60.00				
Ethernet 1000 Base	60.00				
OC-3 Dedicated Ring	60.00	600.00 ⁽¹⁾	N/A		
OC-12 Dedicated Ring	60.00	600.00 ⁽¹⁾	N/A		
OC-48 Dedicated Ring	60.00	600.00 ⁽¹⁾	N/A		
OC-192 Dedicated Ring	60.00	2,250.00 ⁽¹⁾	N/A		

⁽¹⁾ Per circuit charge for Dedicated Ring Service is applied once per original ring installed.

Re-Map Service

(Z)

All States

Initial Service Script Establishment/Test Charge

Per OC-3 Ring	NRMR1	2,000.00
Per OC-12 Ring	NRMR1	3,500.00
Per OC-12 DDN Ring	NRMR2	2,000.00
Per OC-48 Ring	NRMR1	4,500.00
Per OC-192 Ring	NRMR1	5,500.00

Subsequent Script Activity Charge

Per OC-3 Ring	NRMR3	1,200.00
Per OC-12 Ring	NRMR3	2,100.00
Per OC-12 DDN Ring	NRMR4	1,200.00
Per OC-48 Ring	NRMR3	2,700.00
Per OC-192 Ring	NRMR3	3,200.00

Scheduled Test Charge

Per OC-3 Ring	NRMR5	1,600.00
Per OC-12 Ring	NRMR5	2,800.00
Per OC-12 DDN Ring	NRMR6	1,600.00
Per OC-48 Ring	NRMR5	3,600.00
Per OC-192 Ring	NRMR5	4,200.00

Emergency Re-Map Activation
 -per request

Per OC-3 Ring	NRMR7	1,800.00
Per OC-12 Ring	NRMR7	3,150.00
Per OC-12 DDN Ring	NRMR8	1,800.00
Per OC-48 Ring	NRMR7	4,050.00
Per OC-192 Ring	NRMR7	5,000.00

(Z)

SECTION 7 - Special Access Services

		Administrative Charge per order	Design and Central Office Connection Charge, per circuit	Customer Connection Charge per termination	(Z)
	USOC	ORCMX	NRBCL	NRBBL	
GigaMAN [®]					
All States					
12 Month		60.00	230.00	\$1,500.00	
36 Month		60.00 ⁽¹⁾	230.00 ⁽¹⁾	1,500.00 ⁽¹⁾	
60 Month		60.00 ⁽¹⁾	230.00 ⁽¹⁾	1,500.00 ⁽¹⁾	
Renewal GigaMAN [®] Service					
1, 3,& 5 Year TPP		60.00	N/A	N/A	

⁽¹⁾ The Administrative, Design Central Office Connection and Customer Connection non-recurring charges will be waived for 36 and 60-month terms for new service. (Z)

7.5.16 Optional Payment Plan Vintage Rates

A. General Conditions

Optional Payment Plan (OPP) vintage rates are those rates that apply to existing services provided under an OPP term in the event the Telephone Company initiates a rate increase. Vintage rates as set forth following are classified as vintage because the Telephone Company ensures that rates provided under an OPP term will not be increased by the Telephone Company above the OPP rate in effect at the beginning of the customer's OPP term. Each Telephone Company Wire Center has been assigned to a rate zone. To determine the rate zone wire center assignments use the following:

- For OPP terms in effect prior to November 18, 2000, wire center rate zone assignments can be found in Section 7.7 of Tariff F.C.C. No. 2,
- For OPP terms in effect on or after November 18, 2000, wire center rate zone assignments can be found in National Exchange Carrier Association, Inc. Tariff F.C.C. No. 4. (T)
(T)

Customers under their current OPP term will continue to pay the rates as shown in Section 7.5.16(B) until such time as:

- the effective rate in Section 7.5.9 of Tariff F.C.C. No. 2 becomes lower than the vintage rate,
- the assignment of a new rate zone involves a lower rate,
- the customer's existing OPP term expires, or
- the service is terminated by the customer.

In addition, other customer modifications, other than termination, that cause a new rate or OPP term to be established will result in the service becoming non-vintage and the rates as specified in Sections 7.5, 7.5.10 and 7.5.11 of this Guidebook, will apply.

B. Vintage Rates

1. The following rates apply to OC-3 services installed prior to July 1, 1999, unless rates as specified under Section 7.5.10(A) are lower, in which case the referenced rates apply. (T)

	Recurring Rates	
	Optional Payment Plan	
	24 Mo.	48 Mo.
Local Distribution Channel		
- Per Point of Termination		
Terminating Bit Rate		
155.52 Mbps		
All States	\$1,527.00	\$1,253.00
Channel Mileage Termination		
- Per Point of Termination		
Terminating Bit Rate		
155.52 Mbps		
All States	446.00	385.00
Channel Mileage		
- Per Mile		
Terminating Bit Rate		
155.52 Mbps		
All States	238.00	205.00
OC-3 Add/Drop Multiplexing		
- Per Arrangement		
All States	1,052.00	863.00

2. The following rates apply to Ameritech OC-12 services installed prior to July 1, 1999, unless rates as specified under Section 7.5.10(B) are lower, in which case the referenced rates apply. (T)

	Recurring Rates	
	Optional Payment Plan	
	24 Mo.	48 Mo.
Local Distribution Channel		
- Per Point of Termination		
Terminating Bit Rate		
622.08 Mbps		
All States	\$3,800.00	\$3,120.00
Channel Mileage Termination		
- Per Point of Termination		
Terminating Bit Rate		
622.08 Mbps		
All States	665.00	574.00
Channel Mileage		
- Per Mile		
Terminating Bit Rate		
622.08 Mbps		
All States	475.00	410.00
OC-12 Add/Drop Multiplexing		
- Per Arrangement		
All States	2,613.00	2,145.00

3. The following rates apply to OC-48 services installed prior to July 1, 1999, unless rates as specified under Section 7.5.10(C) are lower, in which case the referenced rates apply. (T)

	Recurring Rates	
	Optional Payment Plan	
	24 Mo.	48 Mo.
Local Distribution Channel		
- Per Point of Termination		
Terminating Bit Rate		
2488.32 Mbps		
All States	\$7,600.00	\$6,240.00
Channel Mileage Termination		
- Per Point of Termination		
Terminating Bit Rate		
2488.32 Mbps		
All States	1,496.00	1,386.00
Channel Mileage		
- Per Mile		
Terminating Bit Rate		
2488.32 Mbps		
All States	533.00	479.00
OC-48 Add/Drop Multiplexing		
- Per Arrangement		
All States	1,306.00	1,073.00

4. The following rates apply to OC-3 services installed prior to January 11, 2002, unless rates as specified under Section 7.5.9(C) are lower, in which case the referenced rates apply. (T)

	USOC	12 Mo.	Recurring Charges Optional Payment Plan	
			24 Mo.*	48 Mo.*
Local Distribution Channel				
- Per Point of Termination Terminating Bit Rate 155.52 Mbps				
- All States	TMECS	1,607.00	1,600.00	1,300.00
Channel Mileage Termination				
- Per Point of Termination				
- Per Point of Mileage Termination 155.52 Mbps				
- All States	CM6	469.00	469.00	399.00
Channel Mileage				
- Per Mile 155.52 Mbps				
- All States	1L5XX	250.00	300.00	250.00
Optional Features and Functions				
(a) OC-3 Add/Drop Multiplexing				
- Per Arrangement	MPECX	1,107.00	1,107.00	939.00

4. The following rates apply to OC-12 services installed prior to January 11, 2002, unless rates as specified under Section 7.5.9(C) are lower, in which case (T) referenced rates apply.

	USOC	Recurring Charges Optional Payment Plan		
		12 Mo.	24 Mo.*	48 Mo.*
Local Distribution Channel				
- Per Point of Termination Terminating Bit Rate 622.08 Mbps				
-All States	TMECS	4,000.00	3,700.00	3,000.00
Channel Mileage Termination				
- Per Point of Termination				
-Per Point of Mileage Termination 622.08 Mbps				
- All States	CM6	700.00	700.00	595.00
Channel Mileage				
- Per Mile 622.08 Mbps				
- All States	1L5XX	500.00	300.00	250.00
Optional Features and Functions				
(a) OC-12 Add/Drop Multiplexing				
- Per Arrangement	MPEDX	2,750.00	2,750.00	2,340.00

4. The following rates apply to OC-48 services installed prior to January 11, 2002, unless rates as specified under Section 7.5.9(C) are lower, in which case the referenced rates apply. (T)

	USOC	Recurring Charges Optional Payment Plan		
		12 Mo.	24 Mo.*	48 Mo.*
Local Distribution Channel				
- Per Point of Termination Terminating Bit Rate 2488.32 Mbps				
- All States	TMECS	\$8,000.00	\$8,000.00	\$6,600.00
Channel Mileage Termination				
- Per Point of Mileage Termination 2488.32 Mbps				
- All States	CM6	1,575.00	1,575.00	1,420.00
Channel Mileage				
- Per Mile 2488.32 Mbps				
- All States	1L5XX	550.00	300.00	250.00
Optional Features and Functions				
(a) OC-48 Add/Drop Multiplexing				
- Per Arrangement (not to exceed 12 DS3s or equivalent)				
	MXRFX	1,375.00	1,375.00	1,170.00

5. The following rates apply to OC-3/OC-3c services installed prior to July 2, 2002, unless rates as specified under Section 7.5.9(C) are lower, in which case the referenced rates apply. (T)

	USOC	12 Month	36 Month	60 Month
Channel Mileage				
-Per Mile 155.52 Mbps				
- All States	1L5XX	\$250.00	\$213.00	\$200.00

6. The following rates apply to Video Services installed between September 15, 1999 and June 30, 2003.

Serial Component	USOC	12 Mo.	24 Mo.	36 Mo.	48 Mo.	60 Mo.
Video Service (SCVS)						
Channel Mileage						
-Per Mile						
-All States	1L5XX	70.00	69.00	68.00	67.00	66.00

7. The following rates apply to Optical Carrier Network (OCN) Point-to-Point Services installed between September 13, 2002 and June 30, 2003.

OC-3/OC-3c	USOC	60 Mo.
Channel Mileage		
-Per Mile		
-All States	1L5XX	220.00

OC-12/OC-12c		
Channel Mileage		
-Per Mile		
-All States	1L5XX	220.00

OC-48/OC-48c		
Local Distribution		
-Per point of Termination		
-All States	TMECS	5,560.00

Channel Mileage Termination		
-Per point of Termination		
-All States	CM6	1,340.00

Channel Mileage		
-Per Mile		
-All States	1L5XX	220.00

OC-48 Add/Drop Multiplexing		
-Per Arrangement	MXRFX	500.00

8. The following rates apply to Dedicated Ring Services installed between September 13, 2002 and June 30, 2003.

Node	USOC	36 Mo.	60 Mo.
OC-3			
-Customer Premises			
-First	FP5CX	1,770.00	1,415.00
OC-12			
-Customer Premises			
-First	FP5DX		3,080.00
-Additional	RN8DA		2,095.00

9. The following rates apply to Dedicated Ring Services installed between September 13, 2002 and June 30, 2003.

Node	USOC	36 Mo.	60 Mo.
OC-48 -Customer Premises	FP5EX		4,500.00
OC-48 Add/Drop -Per Arrangement -Plus	MPEFX MPEPX	800.00	600.00 600.00
Ports			
-OC-12, OC-12c at OC-48 Node	SPRHX		360.00
Mileage			
-OC-3	1L5XX		220.00
-OC-12	1L5XX		220.00
-OC-48	1L5XX		220.00

10. The following rates apply to OC-3, OC-12, OC-48 and OC-192 Dedicated Ring Service installed between December 25, 2003 through June 30, 2004.

-Per ports	USOC	36 Mo.	60 Mo.
OC-3, OC-3c at OC-192 Node		S9NEX 150.00	135.00
OC-12, OC-12c at OC-192 Node		S9NGX 375.00	360.00
OC-48, OC-48c at OC-192 Node		S9NJX 950.00	900.00

11. The following rates apply to Multi-service Optical Network (MON) Ring Service installed between June 13, 2003 and January 18, 2005.

	USOC	Monthly Rates	
		3 Year	5 Year
(1) Customer Premises Node (includes first shelf)	F2ND1	\$12,000.00	\$9,600.00
(2) Customer Premises Node -per subsequent shelf	F2NDS	9,000.00	7,200.00
(3) Central Office Node (includes first shelf)	F2NC1	12,000.00	9,600.00
(4) Central Office Node -per subsequent shelf	F2NCS	9,000.00	7,200.00
(5) Channel Mileage -per V-H mile or fraction thereof (2 mile min.)	1L5XX	500.00	400.00

-
12. The following rates apply to Optical Carrier Network (OCN) Point-to-Point Service installed between July 2, 2002 and January 25, 2005.

OC-12/OC-12c Service	USOC	60 Month
Local Distribution Channel		
-Per Point of Termination Terminating Bit Rate 622.08 Mbps		
-All States	TMECS	\$2,600.00

13. The following rates apply to Optical Carrier Network (OCN) Point-to-Point Service installed between July 1, 2003 and January 25, 2005.

OC-48/OC-48c Service	USOC	60 Month
Local Distribution Channel		
-Per Point of Termination Terminating Bit Rate 2488.32 Mbps		
-All States	TMECS	\$4,800.00

14. The following rates apply to Optical Carrier Network (OCN) Point-to-Point Service installed between October 21, 2003 and June 30, 2005.

OC-3/OC-3c Service

Local Distribution Channel
- Per Point of Termination
Terminating Bit
Rate 155.52 Mbps
- All States

USOC	12 Month	36 Month
TMECS	\$1,607.00	\$1,368.00

Channel Mileage
- Per Mile
155.52 Mbps
- All States

USOC	36 Month	60 Months
1L5XX	\$260.00	\$210.00

15. The following rates apply to Optical Carrier Network (OCN) Point-to-Point Service installed between January 26, 2005 and June 30, 2005.

OC-12/OC-12c Service

Local Distribution Channel
- Per Point of Termination
Terminating Bit
Rate 622.08 Mbps
- All States

USOC	12 Month	36 Month
TMECS	\$3,800.00	\$3,200.00

16. The following rates apply to Optical Carrier Network (OCN) Point-to-Point Service installed between October 21, 2003 and June 30, 2005.

OC-12/OC-12c Service

Channel Mileage Termination
 - Per Point of Termination
 - Per Point of Mileage Termination
 622.08 Mbps
 - All States

USOC 60 Month

CM6 \$560.00

Channel Mileage
 - Per Mile
 622.08 Mbps
 - All States

USOC 12 Month 36 Month 60 Month

1L5XX \$500.00 \$260.00 \$210.00

OC-48/OC-48c Service

Local Distribution Channel
 - Per Point of Termination
 Terminating Bit
 Rate 2488.32 Mbps
 - All States

USOC 60 Month

TMECS \$4,617.00

Channel Mileage
 - Per Mile
 2488.32 Mbps
 - All States

USOC 12 Month 36 Month 36 Month

1L5XX \$550.00 \$400.00 \$210.00

17. The following rates apply to Optical Carrier Network (OCN) Point-to-Point Service installed between April 30, 2005 and June 30, 2005.

OC-192/OC-192c Service

Channel Mileage
 Termination
 -Per Point of
 Mileage Termination
 9953.28 Mbps
 - All States

USOC	36 Month	60 Month
CM6	\$4,260.00	\$4,020.00

Channel Mileage
 - Per Mile
 9953.28 Mbps
 - All States

USOC	12 Month	60 Month
1L5XX	\$520.00	\$440.00

18. The following rates apply to OC-3, OC-12, OC-48 and OC-192 Dedicated Ring Service installed between December 25, 2003 and June 30, 2005.

OC3			
-	Customer Premises First	USOC FP5CX	36 Month 60 Month \$1,300.00
OC12			
-	Customer Premise Additional	FP5DA	\$2,095.00
	Additional Re-Map	RN8DA	\$2,000.00
-	Central Office	FC5DX	\$2,095.00
OC-48			
-	Customer Premise First	FP5EX	\$4,300.00
-	Central Office	FC5EX	\$5,000.00 \$4,000.00

19. The following rates apply to OC-3, OC-12, OC-48 and OC-192 Dedicated Ring Service installed between May 28, 2005 and June 30, 2005.

Ports

	USOC	12 Month	60 Month
DS3 at OC3 Node	SPRBX	\$120.00	\$110.00
DS3 at OC-12 (DDN)	SPRMX	120.00	110.00
DS3 at OC-12 Node	SPRCX	120.00	110.00
OC-3, OC-3c at OC-12 Node	SPREX	150.00	135.00
OC-12, OC-12c at OC-48 Node	SPRHX	375.00	355.00
OC-3, OC-3c at OC-48 Node	SPRJX	150.00	135.00
DS3 at OC-48 Node	SPRKX	120.00	110.00
OC-48, OC-48c at OC-192 Node	S9NJX		760.00
DS3 at OC-192 Node	S9QGX	120.00	110.00

20. The following rates apply to OC-3, OC-12, OC-48 and OC-192 Dedicated Ring Service installed between March 22, 2005 and June 30, 2005.

Mileage

Per mile between nodes by ring type

<u>Description</u>	<u>USOC</u>	<u>60 Month</u>
OC-3	1L5XX	\$210.00
OC-12	1L5XX	210.00
OC-48	1L5XX	210.00
OC-192	1L5XX	200.00

21. The following rates apply to OC-3, OC-12, OC-48 and OC-192 Dedicated Ring Service installed between October 21, 2003 and June 30, 2005.

Dedicated Ring Regenerator

<u>Description</u>	<u>USOC</u>	<u>60 Month</u>
OC-48		
Each (as required)	RGY	\$2,620.00

22. The following rates apply to OC-3 services installed between October 21, 2003 and June 30, 2005.

		Recurring Charges Optional Payment Plan	
		24 Mo.	48 Mo.
Local Distribution Channel	USOC		
- Per Point of Termination Terminating Bit Rate 155.52 Mbps			
- All States	TMECS	1,607.00	1,368.00
Channel Mileage			
- Per Mile 155.52 Mbps			
- All States	1L5XX	250.00	213.00

23. The following rates apply to OC-12 services installed between October 21, 2003 and June 30, 2005.

		Recurring Charges Optional Payment Plan	
		24 Mo.*	48 Mo.*
Local Distribution Channel	USOC		
- Per Point of Termination Terminating Bit Rate 622.08 Mbps			
- All States	TMECS	4,000.00	3,400.00
Channel Mileage			
- Per Mile 622.08 Mbps			
- All States	1L5XX	500.00	425.00

24. The following rates apply to OC-48 services installed between October 21, 2003 and June 30, 2005.

		Recurring Charges Optional Payment Plan	
		USOC	
			24 Mo.* 48 Mo.*
Channel Mileage			
- Per Mile			
2488.32 Mbps			
- All States	1L5XX	550.00	400.00