

2. General Regulations

2.1 Undertaking of the Telephone Company

2.1.1 Scope

- (A) The Telephone Company does not undertake to transmit messages under this tariff.
- (B) The Telephone Company shall be responsible only for the installation, operation and maintenance of the services which it provides.
- (C) The Telephone Company will, for maintenance purposes, test its services only to the extent necessary to detect and/or clear troubles.
- (D) Services are provided 24 hours daily, seven days per week, except as set forth in other applicable sections of this tariff.
- (E) The Telephone Company does not warrant that its facilities and services meet standards other than those set forth in this tariff.
- (F) The regulations set forth in this tariff shall apply to (1) access services ordered by a customer pursuant to Section 5, as well as to (2) facilities provisioned by the Telephone Company on behalf of a customer as DS1 or DS3 loop or transport, entrance facilities, dedicated DS0 and/or Optical Carrier Network unbundled network elements (UNEs), but which, as of March 12, 2006, are no longer available as UNEs and for which no alternative arrangements have been made as of March 12, 2006.

(N)

2.1.2 Limitations

- (A) The customer may not assign or transfer the use of services provided under this tariff; however, where there is no interruption of use or relocation of the services, such assignment or transfer may be made to:
 - (1) another customer, whether an individual, partnership, association or corporation, provided the assignee or transferee assumes all outstanding indebtedness for such services, and the unexpired portion of the minimum period and the termination liability applicable to such services, if any; or
 - (2) a court appointed receiver, trustee or other person acting pursuant to law in bankruptcy, receivership, reorganization, insolvency, liquidation or other similar proceedings, provided the assignee or transferee assumes the unexpired portion of the minimum period and the termination liability applicable to such services, if any.

(N)

In all cases of assignment or transfer, the written acknowledgment of the Telephone Company is required prior to such assignment or transfer which acknowledgment shall be made within 15 days from the receipt of notification. All regulations and conditions contained in this tariff shall apply to such assignee or transferee.

(This page filed under Transmittal No. 1530)

2. General Regulations (Cont'd)

2.1 Undertaking of the Telephone Company (Cont'd)

2.1.2 Limitations (Cont'd)

(A) (Cont'd)

The assignment or transfer of services does not relieve or discharge the assignor or transferor from remaining jointly or severally liable with the assignee or transferee for any obligations existing at the time of the assignment or transfer.

(B) The regulations for the installation and restoration of Telecommunications Service Priority (TSP) system services shall be subject to Part 64.401, Appendix A, of the Federal Communications Commission's Rules and Regulations, and Section 10 following, which specifies the priority system for such activities.

C
|
C

(C) Subject to compliance with the rules mentioned in (B) preceding, the services offered herein will be provided to customers on a first-come, first-served basis.

2.1.3 Liability

(A) The Telephone Company's liability, if any, for its willful misconduct is not limited by this tariff. With respect to any other claim or suit, by a customer, or by any others, for damages associated with the installation, provision, preemption, termination, maintenance, repair or restoration of service, and subject to the provisions of (B) through (H) following, the Telephone Company's liability, if any, shall not exceed an amount equal to the proportionate charge for the service for the period during which the service was affected. This liability for damages shall be in addition to any amounts that may otherwise be due the customer under this tariff as a Credit Allowance for a Service Interruption.

C

(B) The Telephone Company shall not be liable for any act or omission of any other carrier or customer providing a portion of a service, nor shall the Telephone Company for its own act or omission hold liable any other carrier or customer providing a portion of a service.

(This page filed under Transmittal No. 507)

2. General Regulations (Cont'd)

2.1 Undertaking of the Telephone Company (Cont'd)

2.1.3 Liability (Cont'd)

- (C) The Telephone Company is not liable for damages to the customer premises resulting from the furnishing of a service, including the installation and removal of equipment and associated wiring, unless the damage is caused by the Telephone Company's negligence. T
- (D) The Telephone Company shall be indemnified, defended and held harmless by the end user against any claim, loss or damage arising from the end user's use of services offered under this tariff, involving: T
- (1) Claims for libel, slander, invasion of privacy, or infringement of copyright arising from the end user's own communications;
 - (2) Claims for patent infringement arising from the end user's acts combining or using the service furnished by the Telephone Company in connection with facilities or equipment furnished by the end user or IC or;
 - (3) All other claims arising out of any act or omission of the end user in the course of using services provided pursuant to this tariff.
- (E) The Telephone Company shall be indemnified, defended and held harmless by the IC against any claim, loss or damage arising from the IC's use of services offered under this tariff, involving: T
- (1) Claims for libel, slander, invasion of privacy, or infringement of copyright arising from the IC's own communications;
 - (2) Claims for patent infringement arising from the IC's acts combining or using the service furnished by the Telephone Company in connection with facilities or equipment furnished by the end user or IC or;
 - (3) All other claims arising out of any act or omission of the IC in the course of using services provided pursuant to this tariff.

(This page filed under Transmittal No. 27)

ACCESS SERVICE

2. General Regulations (Cont'd)

2.1 Undertaking of the Telephone Company (Cont'd)

2.1.3 Liability (Cont'd)

- (F) The Telephone Company does not guarantee or make any warranty with respect to its services when used in an explosive atmosphere. The Telephone Company shall be indemnified, defended and held harmless by the customer from any and all claims by any person relating to such customer's use of services so provided.
- (G) No license under patents (other than the limited license to use) is granted by the Telephone Company or shall be implied or arise by estoppel, with respect to any service offered under this tariff. The Telephone Company will defend the customer against claims of patent infringement arising solely from the use by the customer of services offered under this tariff and will indemnify such customer for any damages awarded based solely on such claims.
- (H) The Telephone Company's failure to provide or maintain services under this tariff shall be excused by labor difficulties, governmental orders, civil commotions, criminal actions taken against the Telephone Company, acts of God and other circumstances beyond the Telephone Company's reasonable control, subject to the Credit Allowance for a Service Interruption as set forth in 2.4.4. following.

2.1.4 Provision of Services

The Telephone Company, to the extent that such services are or can be made available with reasonable effort, and after provision has been made for the Telephone Company's Telephone Exchange Services, will provide to the customer upon reasonable notice services offered in other applicable sections of this tariff at rates and charges specified therein.

(x)

(x)

(x) Issued under authority of Special Permission No. 08-027 of the FCC in order to withdraw material filed under Transmittal No. 1690 without it becoming effective.

(This page filed under Transmittal No. 1692)

ACCESS SERVICE

(x)

(x)

(x) Issued under authority of Special Permission No. 08-027 of the FCC in order to withdraw material filed under Transmittal No. 1690 without it becoming effective.

(This page filed under Transmittal No. 1692)

Issued: December 18, 2008

Effective: December 19, 2008

Four AT&T Plaza, Dallas, Texas 75202

ACCESS SERVICE

(x)

(x)

(x) Issued under authority of Special Permission No. 08-027 of the FCC in order to withdraw material filed under Transmittal No. 1690 without it becoming effective.

(This page filed under Transmittal No. 1692)

Issued: December 18, 2008

Effective: December 19, 2008

Four AT&T Plaza, Dallas, Texas 75202

2. General Regulations (Cont'd)

2.1 Undertaking of the Telephone Company (Cont'd)

2.1.5 Installation and Termination of Services

The services provided under this tariff will include any entrance cable or drop wiring and wire or intrabuilding network cable to that point where provision is made for termination of the Telephone Company's outside distribution network facilities at a suitable location, and will be installed by the Telephone Company to such point, designated as the Network Interface. Technical parameters of services provided under this tariff shall be measured at a Point of Termination to be referred to as the Service Interface (SI). The Service Interface shall be located at the Network Interface or may be extended at the customer's request. Wire and equipment required to extend Access Service facilities will be provided by the Telephone Company, at the customer's request, on a deregulated basis. This wire and equipment may also be provided by the customer. In either case, the customer shall own the wire and equipment beyond the Network Interface. For some services, Telephone Company provided equipment may be placed at an extended SI, causing the customer owned inside wire to be interpositioned. Access Service has only one Point of Termination (Service Interface) per customer premises. Any additional termination beyond such Point of Termination is the sole responsibility of the customer.

T

T

T

2.1.6 Maintenance of Services

The services provided under this tariff shall be maintained by the Telephone Company. The customer or others may not rearrange, move, disconnect, remove or attempt to repair any facilities provided by the Telephone Company, other than by connection or disconnection to any interface means used, except with the written consent of the Telephone Company. Customer owned inside wire maintenance is the customer's responsibility, but may be maintained by the Telephone Company at the customer's request, on a deregulated basis. When trouble on an Access Service is caused by facilities, equipment or wiring owned by the customer, a charge will apply on a deregulated basis.

(This page filed under Transmittal No. 601)

2. General Regulations (Cont'd)

2.1 Undertaking of the Telephone Company (Cont'd)

2.1.7 Changes and Substitutions

Except as provided for equipment and systems subject to F.C.C. Part 68 Regulations at 47 C.F.R. Section 68.110(b), the Telephone Company may, where such action is reasonably required in the operation of its business, (A) substitute, change or rearrange any facilities used in providing service under this tariff, including but not limited to, (1) substitution of different metallic facilities, (2) substitution of carrier or derived facilities for metallic facilities used to provide other than metallic facilities and (3) substitution of metallic facilities for carrier or derived facilities used to provide other than metallic facilities, (B) change minimum protection criteria, (C) change operating or maintenance characteristics of facilities or (D) change operations or procedures of the Telephone Company. In case of any such substitution, change or rearrangement, the transmission parameters will be within the range as set forth in 6. and 7. following. The Telephone Company shall not be responsible if any such substitution, change or rearrangement renders any customer furnished services obsolete or requires modification or alteration thereof or otherwise affects their use or performance. If such substitution, change or rearrangement materially affects the operating characteristics of the facility, the Telephone Company will provide reasonable notification to the customer in writing. Reasonable time will be allowed for any redesign and implementation required by the change in operating characteristics. The Telephone Company will work cooperatively with the customer to determine reasonable notification requirements.

2.1.8 Refusal and Discontinuance of Service

The Telephone Company may refuse additional applications for service or discontinue the provision of services as set forth in 2.1.8(A)(1) and 2.1.8(A)(2) following, unless the provisions of 2.2.1(B) apply, if a customer fails to comply with 2.2.2, 2.3.1, 2.3.4, 2.3.5, 2.4 or 2.5 following, including any payments to be made by it on the dates and times herein specified. (D)

- (A) The Telephone Company may initiate any or all of the actions described in 2.1.8(A)(1) and 2.1.8(A)(2) on fifteen (15) calendar days written notice for failure to comply with the bill payment provisions in 2.4.1 if:
- (i) the Telephone Company has sent the subject bill to the customer within seven (7) business days of the bill date; or
 - (ii) the Telephone Company has sent the subject bill to the customer more than thirty (30) calendar days before notice under this section is given.

The 15 day notice will be made by Overnight Delivery to the person designated by that customer to receive such notices of noncompliance, such notice period to start the day after the notice is sent.

For all other compliance failures not qualifying for 15 day notice, the Telephone Company will give thirty (30) calendar days written notice by Overnight Delivery or Certified U.S. Mail (return receipt requested) to the person designated by that customer to receive such notices of noncompliance, such notice period to start the day after the notice is sent. The Telephone Company will maintain records sufficient to validate the date upon which a bill was sent to a customer.

Overnight Delivery under this section shall be performed by a reputable carrier such as the U.S. Postal Service Express Mail, Airborne, United Parcel Service, or Federal Express.

(This page filed under Transmittal No. 1487)

2. General Regulations (cont'd)

2.1 Undertaking of the Telephone Company (cont'd)

2.1.8 Refusal and Discontinuance of Service (cont'd)

(A) (cont'd)

- (1) Refuse additional applications for service and/or refuse to complete any pending orders for service by the noncomplying customer at anytime thereafter. The Telephone Company may also refuse to accept and process any requests from end users or from the customer to designate that customer as the end user's Primary Interexchange Carrier (PIC), as described in Section 4, following. If an end user contacts the Telephone Company to designate the customer as the end user's PIC, the end user will be given the choice of either remaining with the end user's existing PIC or selecting a new PIC other than the customer. If the Telephone Company does not refuse additional applications for service or PIC changes to the customer on the date specified in the fifteen (15) or thirty (30) days notice, and the customer's noncompliance continues, nothing contained herein shall preclude the Telephone Company's right to refuse additional applications for service to the noncomplying customer or PIC changes to the customer without further notice; or
 - (T)
 - (M)
 - (M)
 - (C)
 - (T)
 - (T)
 - (T)
- (2) Discontinue the provision of the services to the noncomplying customer. If the Telephone Company discontinues service, it will no longer route any switched access traffic that uses the customer's Carrier Identification Code(s) (CIC). In the case of such discontinuance, all applicable charges, including termination charges, shall become due. If the Telephone Company does not discontinue the provision of the services involved on the date specified in the notice and the customer's noncompliance continues, nothing contained herein shall preclude the Telephone Company's right to discontinue the provision of the services to the noncomplying customer without further notice.
 - (D)

(D)

Certain material appearing on this page previously appeared on 7th Revised Page 27.

(This page filed under Transmittal No. 1449)

2. General Regulations (Cont'd)

2.1 Undertaking of the Telephone Company (Cont'd)

2.1.8 Refusal and Discontinuance of Service (Cont'd)

(A) (Cont'd)

(2) (Cont'd)

The Telephone Company will not initiate any of the actions described in paragraphs (1) and (2) above as to disputed bill amounts where the customer does not pay disputed bill amounts by the bill due date as specified in Section 2.4.1(B)(3)(a), and the Telephone Company has not rendered a decision on the dispute. The dispute process is outlined in 2.4.1(B)(3)(c).

(B) When access service is provided by more than one telephone company, the companies involved in providing the joint service may individually or collectively deny service to a customer for nonpayment. Where the telephone companies affected by the nonpayment are incapable of effecting discontinuance of service without cooperation from the other joint providers of Switched Access Service, such other telephone companies will, if technically feasible, assist in denying the joint service to the customer. Service denial for such joint service will only include calls which originate or terminate within, or transit, the operating territory of the telephone companies initiating the service denial for nonpayment. When more than one of the joint providers must deny service to effectuate termination for nonpayment, in cases where a conflict exists in the applicable tariff provisions, the tariff regulations of the telephone company where the customer end office is located shall prevail for joint service discontinuance provisions.

2.1.9 Limitation of Use of Metallic Facilities

Signals applied to a metallic facility shall conform to the limitations set forth in Technical Reference Publication AS No. 1. In the case of application of dc telegraph signaling systems, the customer shall be responsible, at its expense, for the provision of current limiting devices to protect the Telephone Company facilities from excessive current due to abnormal conditions and for the provision of noise mitigation networks when required to reduce excessive noise.

(This page filed under Transmittal No. 1449)

(N)

(N)

ACCESS SERVICE

2. General Regulations (Cont'd)

2.1 Undertaking of the Telephone Company (Cont'd)

2.1.10 Notification of Service-Affecting Activities

The Telephone Company will provide the customer reasonable notification of service-affecting activities that may occur in normal operation of its business. Such activities may include, but are not limited to, equipment or facilities additions, removals or rearrangements, routine preventative maintenance and major switching machine change-out. Generally, such activities are not individual customer service specific, they affect many customer services. No specific advance notification period is applicable to all service activities. The Telephone Company will work cooperatively with the customer to determine reasonable notification requirements.

2.1.11 Coordination with Respect to Network Contingencies

The Telephone Company intends to work cooperatively with the customer to develop network contingency plans in order to maintain maximum network capability following natural or man-made disasters which affect telecommunications services.

2.1.12 Provision and Ownership of Telephone Numbers

The Telephone Company reserves the reasonable right to assign, designate or change telephone numbers, any other call number designations associated with Access Services, or the Telephone Company serving central office prefixes associated with such numbers, when necessary in the conduct of its business. Should it become necessary to make a change in such number(s), the Telephone Company will furnish to the customer six months notice, by Certified U.S. Mail, of the effective date and an explanation of the reason(s) for such change(s).

2.1.13 Broadband Services

Pursuant to the detariffing authority granted by the Commission in Memorandum Opinion and Order, FCC 07-180 (released October 12, 2007), certain broadband services have been withdrawn from this tariff. When offering these services through non-tariffed arrangements, the Telephone Company will abide by all of the special access merger commitments set forth in Memorandum Opinion and Order, FCC 06-189 at Appendix F (released March 26, 2007), including but not limited to commitments that contain references to "tariffs," such as those addressing pricing dispute resolution, and access service ratio terms. The detariffing of these services does not diminish or supersede any of those special access merger commitments.



(This page filed under Transmittal No. 1666)

2. General Regulations (Cont'd)

2.2 Use

2.2.1 Interference or Impairment

- (A) The characteristics and methods of operation of any circuits, facilities or equipment provided by other than the Telephone Company and associated with the facilities utilized to provide services under this tariff shall not interfere with or impair service over any facilities of the Telephone Company, its affiliated companies, or its connecting and concurring carriers involved in its services, cause damage to their plant, impair the privacy of any communications carried over their facilities or create hazards to the employees of any of them or the public.
- (B) Except as provided for equipment or systems subject to the FCC Part 68 Rules in 47 C.F.R. Section 68.108, if such characteristics or methods of operation are not in accordance with (A) preceding, the Telephone Company will, where practicable, notify the customer that temporary discontinuance of the use of a service may be required; however, where prior notice is not practicable, nothing contained herein shall be deemed to preclude the Telephone Company's right to temporarily discontinue forthwith the use of a service if such action is reasonable under the circumstances. In case of such temporary discontinuance, the customer will be promptly notified and afforded the opportunity to correct the condition which gave rise to the temporary discontinuance. During such period of temporary discontinuance, credit allowance for service interruptions as set forth in 2.4.4 (A) and (B) following is not applicable.

2.2.2 Unlawful Use

The service provided under this tariff shall not be used for an unlawful purpose.

(This page filed under Transmittal No. 18)

2. General Regulations (Cont'd)

2.3 Obligations of the Customer

2.3.1 Damages

The customer shall reimburse the Telephone Company for damages to the Telephone Company facilities utilized to provide services under this tariff caused by the negligence or willful act of the customer or resulting from the customer's improper use of the Telephone Company facilities, or due to malfunction of any facilities or equipment provided by other than the Telephone Company. Nothing in the foregoing provision shall be interpreted to hold one customer liable for another customer's actions. The Telephone Company will, upon reimbursement for damages, cooperate with the customer in prosecuting a claim against the person causing such damage and the customer shall be subrogated to the right of recovery by the Telephone Company for the damages to the extent of such payment.

2.3.2 Ownership of Facilities and Theft

Facilities utilized by the Telephone Company to provide service under the provisions of this tariff shall remain the property of the Telephone Company. Such facilities shall be returned to the Telephone Company by the customer, whenever requested, within a reasonable period following the request in as good condition as reasonable wear will permit.

2.3.3 Equipment Space and Power

The customer shall furnish or arrange to have furnished to the Telephone Company, at no charge, equipment space and electrical power required by the Telephone Company to provide services under this tariff at the points of termination of such services. The selection of ac or dc power shall be mutually agreed to by the customer and the Telephone Company. The customer shall also make necessary arrangements in order that the Telephone Company will have access to such spaces at reasonable times for installing, testing, inspecting, repairing or removing Telephone Company services.

2.3.4 Availability for Testing

The services provided under this tariff shall be available to the Telephone Company at times mutually agreed upon in order to permit the Telephone Company to make tests and adjustments appropriate for maintaining the services in satisfactory operating condition. Such tests and adjustments shall be completed within a reasonable time. No credit will be allowed for any interruptions involved during such tests and adjustments.

(This page filed under Transmittal No. 18)

2. General Regulations (Cont'd)

2.3 Obligations of the Customer (Cont'd)

2.3.5 Balance

All signals for transmission over the services provided under this tariff shall be delivered by the customer balanced to ground except for ground start, duplex (DX) and McCulloh-Loop (Alarm System) type signaling and dc telegraph transmission at speeds of 75 baud or less.

2.3.6 Design of Customer Services

Subject to the provisions of 2.1.7 preceding, the customer shall be solely responsible, at its own expense, for the overall design of its services and for any redesigning or rearrangement of its services which may be required because of changes in facilities, operations or procedures of the Telephone Company, minimum protection criteria or operating or maintenance characteristics of the facilities.

2.3.7 References to the Telephone Company

The customer may advise End Users that certain services are provided by the Telephone Company in connection with the service the customer furnishes to End Users; however, the customer shall not represent that the Telephone Company jointly participates in the customer's services.

2.3.8 Claims and Demands for Damages

(A) With respect to claims of patent infringement made by third persons, the customer shall defend, indemnify, protect and save harmless the Telephone Company from and against all claims arising out of the combining with, or use in connection with, the services provided under this tariff, any circuit, apparatus, system or method provided by the customer.

(This page filed under Transmittal No. 18)

2. General Regulations (Cont'd)

2.3 Obligations of the Customer (Cont'd)

2.3.8 Claims and Demands for Damages (Cont'd)

- (B) The customer shall defend, indemnify, protect and save harmless the Telephone Company from and against any and all suits, claims, and demands by third persons arising out of the construction, installation, operation, maintenance, or removal of the customer's circuits, facilities, or equipment connected to the Telephone Company's services provided under this tariff, including, without limitation, Workmen's Compensation claims, actions for infringement of copyright and/or unauthorized use of program material, libel and slander actions based on the content of communications transmitted over the customer's circuits, facilities or equipment, and proceedings to recover taxes, fines, or penalties for failure of the customer to obtain or maintain in effect any necessary certificates, permits, licenses, or other authority to acquire or operate the services provided under this tariff; provided, however, the foregoing indemnification shall not apply to suits, claims, and demands to recover damages for damage to property, death, or personal injury unless such suits, claims or demands are based on the tortious conduct of the customer, its officers, agents or employees.
- (C) The customer shall defend, indemnify and save harmless the Telephone Company from and against any suits, claims, losses or damages, including punitive damages, attorney fees and court costs by the customer or third parties arising out of any act or omission of the customer in the course of using services provided under this tariff.

2.3.9 Coordination with Respect to Network Contingencies

The customer shall, in cooperation with the Telephone Company, coordinate in planning the actions to be taken to maintain maximum network capability following natural or manmade disasters which affect telecommunications services.

(This page filed under Transmittal No. 18)

2. General Regulations (Cont'd)

2.3 Obligations of the Customer (Cont'd)

2.3.10 Jurisdictional Report Requirements

Reporting by the customer of the expected jurisdictional use of Switched Access Service is required because the Telephone Company cannot determine the actual jurisdiction of the customer's usage from every type of call detail recording. In some cases the Telephone Company cannot record the customer's usage of the service at all. The information reported by the customer will be used by the Telephone Company to determine the portion of the customer's service which is subject to interstate charges, as set forth in 2.3.11 following. The customer must report this information for only those services or portions of services for which the actual jurisdictional use cannot be determined from Telephone Company records.

In this section the terms "hunt group" and "trunk group" shall be assumed to also represent a single line or trunk.

(A) Feature Group A

- (1) When a customer orders a new Feature Group A (FGA) Switched Access Service hunt group the customer shall, in its order, state the proportion of the service which is to be provided for interstate use. This proportion is the Percent for Interstate Use or PIU.

When the customer orders an Entrance Facility or a Direct-Trunked Transport Facility in conjunction with FGA Switched Access Service, the customer must report a PIU for the Entrance Facility or Direct-Trunked Transport Facility as set forth in Section 2.3.10(H).

The customer can either specify one general PIU for the total FGA hunt group usage or the customer can specify a toll free terminating PIU and a residual PIU. If the customer chooses to provide a separate toll free terminating PIU, then they must provide one PIU for toll free terminating FGA hunt group usage and one PIU (the residual PIU) for all the remaining FGA hunt group usage. All PIUs shall be stated as whole number percentages (a number of 0 through 100). If the customer chooses to report one general Percent for Interstate Use, then the general PIU will be the customer's best estimate of the percentage of the total use of the FGA hunt group that will be interstate in nature.

C
|
C

(TR940)

(This page filed under Transmittal No. 940)

2. General Regulations (Cont'd)

2.3 Obligations of the Customer (Cont'd)

2.3.10 Jurisdictional Report Requirements (Cont'd)

(A) Feature Group A (Cont'd)

(1) (Cont'd)

If the customer chooses to provide a separate toll free terminating PIU, then that PIU will be the customer's best estimate of the percentage of the total toll free terminating use of the FGA hunt group usage that will be interstate in nature. The residual PIU would then be the customer's best estimate of the percentage of the total FGA hunt group usage that will not be toll free terminating usage and will be interstate in nature.

C
|
C

C

(2) The reported Percentage(s) for Interstate Use PIU(s) will be used in the determination of all interstate and intrastate charges for the FGA hunt group, as set forth in 2.3.11 following. The PIU(s) remains in effect until it is superceded by a revised PIU(s), as set forth in (3) following.

(TR940)

(This page filed under Transmittal No. 940)

2. General Regulations (Cont'd)

2.3 Obligations of the Customer (Cont'd)

2.3.10 Jurisdictional Report Requirements (Cont'd)

(A) Feature Group A (Cont'd)

- (3) When the customer determines that any currently effective PIU(s) for FGA for one or more hunt groups is no longer accurate, the customer shall report a revised PIU(s) for each hunt group. The customer can report the new PIU(s) to the Telephone Company in writing or via magnetic tape. The report must clearly identify each hunt group, the account number under which it is billed, and both the current and revised PIU(s). The revised PIU(s) will become effective on the first day of the next monthly billing period which begins at least 15 business days after the day on which the customer reports the revised PIU(s) to the Telephone Company. No revisions to bills preceding the effective date of the revised PIU(s) will be made based on this report.

(B) Feature Group B

- (1) When a customer orders Feature Group B (FGB) Switched Access Service to a tandem or end office to which the customer does not have existing FGB service, the customer shall, in its order, state the proportion of the FGB service which is to be provided for interstate use for each new end office or for each end office subtending each new tandem office. This proportion is the Percent for Interstate Use or PIU.

When the customer orders an Entrance Facility or a Direct-Trunked Transport Facility in conjunction with FGB Switched Access Service, the customer must report a PIU for the Entrance Facility or Direct-Trunked Transport Facility as set forth in Section 2.3.10(H).

The customer can either specify one general PIU for the total FGB service or the customer can specify a toll free terminating PIU and a residual PIU. If the customer chooses to provide a separate toll free terminating PIU, then they must provide one PIU for toll free terminating FGB service usage and one PIU (the residual PIU) for all remaining FGB service usage.

C
|
C

(TR940)

(This page filed under Transmittal No. 940)

2. General Regulations (Cont'd)

2.3 Obligations of the Customer (Cont'd)

2.3.10 Jurisdictional Report Requirements (Cont'd)

(B) Feature Group B (Cont'd)

(1) (Cont'd)

All PIUs shall be stated as whole number percentages (a number of 0 through 100).

If the customer chooses to report one general Percent for Interstate Use, then this general PIU will be the customer's best estimate of the percentage of the total FGB usage, for that end office, that will be interstate in nature. If the customer chooses to provide a separate toll free terminating PIU, then the toll free terminating PIU will be the customer's best estimate of the percentage of the total toll free terminating FGB usage, for that end office, that will be interstate in nature. The residual PIU will be the customer's best estimate of the percentage of the total FGB usage, for that end office, that will not be toll free terminating usage and will be interstate in nature.

C
C
C

(TR940)

(This page filed under Transmittal No. 940)

2. General Regulations (Cont'd)

2.3 Obligations of the Customer (Cont'd)

2.3.10 Jurisdictional Report Requirements (Cont'd)

(C) Feature Group D, 500 Access Service, 900 Access Service, and Alternate Card service Access (D)

(1) When a customer orders Feature Group D (FGD) Switched Access Service (which may include toll free minutes of use), 500 Access Service and/or 900 Access Service and/or Alternate Card Access service to a tandem or an end office to which the customer does not have existing FGD service, the customer shall, in its order, state the proportion of the service which is to be provided for interstate use for each new end office or for each end office subtending each new tandem office. (D)

When the customer orders an Entrance Facility or a Direct-Trunked Transport Facility in conjunction with FGD Switched Access Service, the customer must report a PIU for the Entrance Facility or Direct-Trunked Transport Facility as set forth in Section 2.3.10(H). (D)

The customer has the option to state their proportion of interstate use separately for the usage types 500 originating, toll free originating, toll free terminating and/or 900 originating or the customer can designate one general Percentage for Interstate Use (PIU) for all FGD usage types. If the customer specifies a unique PIU for 500 originating toll free originating, toll free terminating, and/or 900 originating traffic, then the customer must also provide a separate residual PIU that represents the percent of interstate use for all usage types for which a separate PIU has not been provided for each end office. (D)

All PIUs shall be stated as whole number percentages (a number of 0 through 100), for each end office to which the new FGD service is being ordered. (D)

If the customer chooses to report one general Percent for Interstate Use, then this general PIU will be the customer's best estimate of the percentage of the total FGD (including any toll free traffic), 500 Access Service and/or 900 Access Service, and/or Alternate Card Access service usage, for each end office, that will be interstate in nature. This estimate should not include any originating usage types for which the Telephone Company is able to derive jurisdiction from call detail recording. (D)

(This page filed under Transmittal No. 1801)

2. General Regulations (Cont'd)

2.3 Obligations of the Customer (Cont'd)

2.3.10 Jurisdictional Report Requirements (Cont'd)

- (C) Feature Group D, 500 Access Service, 900 Access Service, and Alternate Card Access service (Cont'd) (D)

(1) Cont'd)

If the customer chooses to provide separate PIUs for 500 originating usage, toll free originating usage, toll free terminating usage and/or 900 originating usage, then the PIU for each usage type identified will be the customer's best estimate of the percentage of interstate usage for that usage type, for each end office. If the customer elects to provide a separate PIU for any usage type, the customer then must provide a residual PIU. The residual PIU will be the customer's best estimate of the percentage of Interstate use for each end office, for all FGD (including any toll free traffic), 500 Access Service and/or 900 Access Service usage types for which a separate PIU has not been provided. This estimate should not include any originating usage types for which the Telephone Company is able to derive jurisdiction from call detail recording. (D)

- (2) When 500 Access Service or 900 Access Service is ordered to an end office at which the customer has existing Feature Group D service, the customer shall provide a revised PIU(s) for that end office as set forth in Section 2.3.10(E)(2) following. (D)

(D) Switched Access Dedicated Network Access Line (DNAL)

- (1) When a customer orders a Switched Access DNAL, the customer shall, in its order, state the proportion of the service which is to be provided for interstate use. This general PIU shall be stated as a whole number percentage (a number of 0 through 100) that is the customer's best estimate of the percentage of the usage for that DNAL that will be interstate in nature.

(E) TRS Provider Transport (TRS-PT)

- (1) When a customer orders a TRS Provider Transport facility, the customer shall, in its order, state the proportion of the service which is to be provided for interstate use for the entire facility. This general PIU shall be stated as a whole number percentage (a number of 0 through 100) that is the customer's best estimate of the percentage of the usage for that TRS-PT facility that will be interstate in nature.

(This page filed under Transmittal No. 1801)

2. General Regulations (Cont'd)

2.3 Obligations of the Customer (Cont'd)

2.3.10 Jurisdictional Report Requirements (Cont'd)

- (E) Application and Revisions of Percentages for Interstate Use for Feature Group B or D, 500 Access Service, 900 Access Service, Alternate Card Access service and DNALs (D)
- (1) The reported Percentage(s) for Interstate Use PIU(s) will be used in the determination of interstate and intrastate charges for FGB, FGD, 500 Access Service, 900 Access Service and/or DNALs to each end office or DNAL, as set forth in 2.3.11 following, until it is superseded by a revised PIU(s), as set forth in (2) following. (D)
- (2) When the customer determines that any currently effective PIU(s) for FGB, FGD, 500 Access Service, 900 Access Service, Alternate Card Access service and/or DNAL for one or more end office or DNAL is no longer accurate, the customer shall report a revised PIU(s) for each end office or DNAL. The customer can report the new PIU(s) to the Telephone Company in writing or via magnetic tape. The report must clearly identify each end office or DNAL, the account number under which it is billed, and both the current and revised PIU(s). This revised PIU(s) will become effective on the first day of the next monthly billing period for the FGB, FGD, 500 Access Service, 900 Access Service, Alternate Card Access service and/or DNAL service which begins at least 15 business days after the day on which the customer reports the revised PIU(s) to the Telephone Company. No revisions to bills preceding the effective date of the revised PIU(s) will be made based on this report. (D)

(This page filed under Transmittal No. 1801)

2. General Regulations (Cont'd)

2.3 Obligations of the Customer (Cont'd)

2.3.10 Jurisdictional Report Requirements (Cont'd)

(F) Switched Access Service Chargeable Optional Features

- (1) When a Switched Access Service chargeable optional feature is provided in an end office the Percentage of Interstate Use (PIU) used in the determination of interstate and intrastate charges for the chargeable optional feature will be either the general PIU or the residual PIU for the associated Feature Group Switched Access Service. If the general PIU was used for the associated Feature Group Switched Access Service, then the general PIU will be used for the jurisdictional determination of the chargeable optional feature. If usage type PIUs and the residual PIU were provided by the customer for the associated Feature Group Switched Access Service, then the residual PIU will be used for the jurisdictional determination of the chargeable optional feature.
- (2) When a Switched Access Service chargeable optional feature is provided in a tandem office, the tandem PIU as set forth in 2.3.10(G) following, will be used in the determination of interstate and intrastate charges.
- (3) When the Tandem Signaling Optional Feature to FGD is ordered, the customer must provide a PIU as specified in 2.3.10(H) following. The customer of record for the FGD Switched Access Service must provide a PIU as specified in 2.3.1(C) preceding.

N
|
N

(This page filed under Transmittal No. 823)

2. General Regulations (Cont'd)

2.3 Obligations of the Customer (Cont'd)

2.3.10 Jurisdictional Report Requirements (Cont'd)

(G) Percentage for Interstate Use for Tandem Routed Switched Access Services

- (1) When a customer orders Feature Group B (FGB), Feature Group D (FGD), 500 Access Service, 900 Access Service, and/or Alternate Card Access service via a tandem office to which the customer does not have existing FGB or FGD service, the customer shall, in its order, state the proportion of the tandem routed service which is to be provided for interstate use. This tandem routed PIU shall be stated as a whole number percentage (a number of 0 through 100) which is the customer's best estimate of the percentage of the total use of the FGB, FGD, 500 Access Service and/or 900 Access Service through the tandem office that will be interstate in nature. (D)
- (2) The reported tandem routed PIU will be used in the determination of monthly and nonrecurring interstate and intrastate charges for FGB and FGD, through the tandem office and for Switched Access Service chargeable optional features provided in tandem offices, as set forth in 2.3.11 following, until it is superceded by a revised tandem routed PIU, as set forth in (3) following. (D)

(This page filed under Transmittal No. 1801)

2. General Regulations (Cont'd)

2.3 Obligations of the Customer (Cont'd)

2.3.10 Jurisdictional Report Requirements (Cont'd)

(G) Percentage for Interstate Use for Tandem Routed Switched Access Services (Cont'd)

- (3) When the customer determines that the currently effective tandem routed PIU for FGB, FGD, 500 Access Service, 900 Access Service, Alternate Card Access service and/or Switched Access chargeable optional features provided in a tandem office is no longer accurate for one or more tandem office, the customer shall report a revised tandem routed PIU for each tandem office. The customer can report the new tandem PIU to the Telephone Company in writing or via magnetic tape. The report must clearly identify each tandem office, the account number under which it is billed, and both the current and revised PIU. This revised tandem routed PIU will become effective on the first day of the next monthly billing period for the FGB, FGD, 500 Access Service, 900 Access Service, Alternate Card Access service and/or Switched Access chargeable optional features, which begins at least 15 business days after the day on which the customer reports the revised tandem routed PIU to the Telephone Company. No revisions to bills preceding the effective date of the revised PIU will be made based on this report. (D)

(H) Direct-Trunked Transport Facilities and Entrance Facilities

- (1) When a customer orders an Entrance Facility between a serving wire center and their point of presence, for which no Entrance Facility PIU has been previously reported, the customer shall, in its order, state the proportion of the facility that is to be provided for interstate use. This Entrance Facility PIU will also be used to determine the jurisdictional use of all subsequent Entrance Facilities ordered between the specific serving wire center and point of presence.

(This page filed under Transmittal No. 1801)

2. General Regulations (Cont'd)

2.3 Obligations of the Customer (Cont'd)

2.3.10 Jurisdictional Report Requirements (Cont'd)

(H) Direct Transport Facilities and Entrance Facilities (Cont'd)

- (2) When a customer orders a Direct Transport Facility between a serving wire center and end office for which no Direct Transport PIU has been previously reported, the customer shall, in its order, state the proportion of the Direct Transport Facility that is to be provided for interstate use. This Direct Transport PIU will also be used to determine the jurisdictional use of all subsequent Direct Transport Facilities ordered between the specific serving wire center and end office.* Tx
Tx
Tx
Tx
- (3) At the customer's option, a consolidated PIU may be reported which includes the proportion of all monthly-rated switched transport elements which is to be provided for interstate use. Nx
Nx

* Switched Access Entrance Facilities and Direct Transport Facilities will be provided by the Telephone Company as of December 30, 1993 pursuant to the Federal Communication Commission's Report and Order and Further Notice of Proposed Rulemaking, CC Docket No. 91-213, released October 16, 1992. In order to determine the portion of Entrance Facilities subject to interstate charges, customers must report a Percentage of Interstate Use (PIU) factor for each point of presence to which the customer anticipates the Telephone Company will have provisioned Entrance Facilities for their Switched Access Services on December 30, 1993. Each Entrance Facility PIU will represent the proportion of interstate use for all Entrance Facilities that will terminate to a given point of presence on December 30, 1993. In order to determine the portion of Direct Transport Facilities subject to interstate charges, customers must report a PIU factor for each serving wire center to end office combination for which the customer anticipates the Telephone Company will have provisioned Direct Transport Facilities on December 30, 1993. This PIU will represent the proportion of interstate use for all Direct Transport Facilities that will be provisioned on December 30, 1993 between each serving wire center to end office combination. Tx
Tx
Tx
Tx

The customer may, at their option, provide one PIU per LATA or state for all Entrance Facilities and one PIU per LATA or state for all Direct Transport Facilities that they anticipate will be provisioned by December 30, 1993. The customer must report these new PIUs to the Telephone Company by September 15, 1993. Tx
Tx

(This page filed under Transmittal No. 764)

2. General Regulations (Cont'd)

2.3 Obligations of the Customer (Cont'd)

2.3.10 Jurisdictional Report Requirements (Cont'd)

(H) Direct Transport Facilities and Entrance Facilities (Cont'd)

- (4) The PIU(s) reported by the customer for Entrance Facilities and/or Direct Transport Facilities shall be stated as a whole number percentage (a number of 0 through 100) which is the customer's best estimate of the proportion of interstate use for all Switched Access Services that are provided over the facility.
- (5) The PIU factor applied for the chargeable Multiplexers, used in conjunction with Entrance Facilities or Direct Transport Facilities, will be the PIU of the associated Entrance Facility or Direct Transport Facility.
- (6) If the customer does not provide a PIU Factor for Entrance Facilities or Direct Transport Facilities as set forth in (1) through (4) above, the Telephone Company will designate a default PIU factor of seventy-five percent (75 %).
- (7) When a customer determines that any currently effective Entrance Facility or Direct Transport PIU is no longer accurate, the customer shall report a revised PIU(s). The revised PIU(s) will become effective on the first day of the next monthly billing period which begins at least 15 days after the day on which the customer reports the revised PIU(s) to the Telephone Company. No revisions to bills preceding the effective date of the revised PIU(s) will be made based on this report.
- (8) Customers that report Entrance Facility PIUs for each point of presence or Direct Transport PIUs for each serving wire center to end office combination may not report revised PIUs more than once each calendar quarter.

T

(TR849)

(This page filed under Transmittal No. 849)

2. General Regulations (Cont'd)

2.3 Obligations of the Customer (Cont'd)

2.3.10 Jurisdictional Report Requirements (Cont'd)

(I) Directory Assistance Service

- (1) When a customer orders a new Directory Assistance Service group, or Ameritech Directory Search (ADS) service, the customer shall, in its order, state the proportion of the service which is to be provided for interstate use. The number shall be stated as a whole number percentage (a number of 0 through 100) that is the customer's best estimate of the percentage of the usage for that Directory Assistance Service group that will be interstate in nature.
- (2) This reported Percentage for Interstate Use (PIU) will be used in the determination of interstate and intrastate charges for one or more Directory Assistance Service groups or Ameritech Directory Search (ADS) service, as set forth in 2.3.11 following, until it is superseded by a revised PIU, as set forth in (3) following.
- (3) When the customer determines that the currently effective PIU for one or more Directory Assistance Service groups or ADS service is no longer accurate, the customer shall report to the Telephone Company a revised PIU for each such service group or ADS service. The customer must report the new PIU(s) for ADS service to the Telephone Company in writing. The customer has the option to report the new PIU(s) for Directory Assistance Service groups to the Telephone Company in writing or via magnetic tape. The report must clearly identify each such service group or ADS service, the account number under which it is billed, and both the current and revised PIU. This revised PIU will become effective on the first day of the next monthly billing period for the Directory Assistance Service or ADS service which begins at least 15 business days after the day on which the customer reports the revised PIU to the Telephone Company. No revisions to bills preceding the effective date of the revised PIU will be made based on this report.
- (4) When the customer orders an Entrance Facility or Direct-Trunked Transport Facility in conjunction with a new Directory Assistance Service group or Ameritech Directory Search (ADS) service, the customer must report a PIU for the Entrance Facility or Direct-Trunked Transport Facility as set forth in Section 2.3.10(H).

T
 M
 M
 N
 N

Certain material previously on this page now appears on 8th Revised Page 38.1.
 Certain material on this page previously appeared on 1st Revised Page 37.3.

(This page filed under Transmittal No. 721)

2. General Regulations (Cont'd)

2.3 Obligations of the Customer (Cont'd)

2.3.10 Jurisdictional Report Requirements (Cont'd)

(J) Data Base Services

(1) 800 Service

- (a) When an 800 Call-Routing query, as described in 6.4.1(A) following, is performed to determine the routing of a call, and the associated Switched Access service is provided in whole or in part by the Telephone Company, the Percentage for Interstate Use (PIU) for the query will be the same as that of the Switched Access service, as described in (C) or (G) preceding.
- (b) When a customer's 800 Call-Routing queries include one or more routing options, as described in 6.4.1(A) following, the customer shall provide the Telephone Company with the proportion of the routing-option queries which is to be provided for interstate use. A PIU should be provided for each Service Switching Point (SSP) from which 800 queries may originate.
- (c) When a customer requests 800 Carrier-ID-Only service, as described in 6.4.1(B) following, the customer shall state in its order the proportion of the service which is to be provided for interstate use.

Dx

Dx

- (d) Each PIU described above shall be stated as a whole number percentage (a number 0 through 100) which is the customer's best estimate of the percentage of traffic that will be interstate in nature.
- (e) When the customer determines that any currently effective PIU is no longer accurate, the customer shall report a revised PIU(s). As appropriate, the report must clearly identify the type of query, the SSP or the ten-digit toll free number. The revised PIU(s) will become effective on the first day of the next monthly billing period which begins at least 15 days after the day on which the customer reports the revised PIU(s) to the Telephone Company. No revisions to bills preceding the effective date of the revised PIU(s) will be made based on this report.



Tx

Tx

x Issued under authority of Special Permission No. 97-30.

(TR1051)

(This page filed under Transmittal No. 1051)

2. General Regulations (Cont'd)

2.3 Obligations of the Customer (Cont'd)

2.3.10 Jurisdictional Report Requirements (Cont'd)

Dx

Dx

(J) TRS Provider Transport (TRS-PT)

Tx

When a customer orders a TRS Provider Transport facility, the customer shall, in its order, state the proportion of the service which is to be provided for interstate use for the entire facility. This general PIU shall be stated as a whole number percentage (a number of 0 through 100) that is the customer's best estimate of the percentage of the usage for that TRS-PT facility that will be interstate in nature.

(K) Cross-Connection to Switched Access Services

Tx

(1) When a customer orders an Ameritech Cross-Connection Service for Interconnection (ACCSI) to Direct-Trunked Transport at a serving wire center, an end office or a tandem switch, for which no ACCSI PIU has been previously reported, the customer must, in its order, state the proportion of the service which is to be provided for interstate use. If there is a corresponding cross-connection rate element in the state interconnection tariff, and the cross-connection rate element in the state interconnection tariff, and the cross-connection is used to connect to a service for which the interstate use is less than 10 percent, the customer may specify a proportion of 0 percent. This reported PIU will also be used to determine the jurisdictional use of all subsequent ACCSI ordered at that specific serving wire center or end office.

(2) The PIU reported by the customer shall be stated as a whole number percentage (0 or 100).

(3) If the customer does not provide a PIU factor for ACCSI services as set forth above, the Telephone Company will designate a default PIU factor of one hundred percent (100%).

x Issued under authority of Special Permission No. 97-30.

(TR1051)

(This page filed under Transmittal No. 1051)

2. General Regulations (Cont'd)

2.3 Obligations of the Customer (Cont'd)

2.3.10 Jurisdictional Report Requirements (Cont'd)

(K) Cross-Connection to Switched Access Services (Cont'd)

Tx

(4) When the customer determines that any currently effective ACCSI PIU is no longer accurate, the customer shall report a revised PIU(s). The revised PIU(s) will become effective on the first day of the next monthly billing period which begins at least 15 days after the day on which the customer reports the revised PIU(s) to the Telephone Company. No revisions to bills preceding the effective date of the revised PIU(s) will be made based on this report.

(5) Customers that report ACCSI PIUs for each end office or serving wire center may not report revised PIUs more than once each calendar quarter.

(L) Determination of Jurisdictional Use

Tx

Pursuant to Federal Communications Commission order FCC 85-145 released April 16, 1985, interstate usage is to be developed as though every call that enters a customer network at a point within the same state as that in which the called station (as designated by the called station number) is situated is an intrastate communication and every call for which the point of entry is in a state other than that where the called station (as designated by the called station number) is situated is an interstate communication.

x Issued under authority of Special Permission No. 97-30.

(TR1051)

(This page filed under Transmittal No. 1051)

Issued: January 12, 1997

Effective: January 27, 1997

Four AT&T Plaza, Dallas, Texas 75202

2. General Regulations (Cont'd)

2.3 Obligations of the Customer (Cont'd)

2.3.10 Jurisdictional Report Requirements (Cont'd)

(M) Level of Reporting Percentages for Interstate Use

Tx

(1) Switched Access Services

The reporting of expected jurisdictional use is required for Switched Access Services by end office and tandem for all Switched Access Services. The Telephone Company will, if requested, assist the customer in its determination of the expected end office specific jurisdictional use. The customer can, however, choose to provide their PIU(s) (general usage type and residual PIUs) for an entire state or LATA. If the customer has chosen to provide only one state or LATA level general PIU, then that general PIU will apply for every end office and tandem in the state or LATA for all charges. If the customer has chosen to provide usage type PIUs, then each state or LATA level usage type PIU will be applied to the appropriate usage type from all end offices in the state or LATA. The state or LATA level residual PIU will be applied to any monthly recurring and nonrecurring charges associated with any end office or tandem in the state or LATA.

(2) Direct-Trunked Transport and Entrance Facilities

The reporting of jurisdictional use is required for each customer's point of presence for Entrance Facilities and for each customer's serving wire center to end office combination for Direct-Trunked Transport Facilities. As an additional option, the customer may provide one PIU for all Entrance Facilities or Direct-Trunked Transport Facilities within the state or LATA. The state or LATA PIU will reflect the proportion of interstate use for the originating and terminating traffic of all Switched Access Services provided over the Entrance Facilities or Direct-Trunked Transport Facilities within the state or LATA. The state or LATA level Direct-Trunked Transport Facility or Entrance Facility PIU will be applied to any monthly recurring and nonrecurring charges associated with all such facilities in the state or LATA.

x Issued under authority of Special Permission No. 97-30.

(TR1051)

(This page filed under Transmittal No. 1051)

2. General Regulations (Cont'd)

2.3 Obligations of the Customer (Cont'd)

2.3.10 Jurisdictional Report Requirements (Cont'd)

(N) Jurisdictional Report Verification

Tx

If a billing dispute arises or a regulatory commission questions the projected interstate percentage, the Telephone Company will ask the customer to provide the data the customer uses to determine the projected interstate percentage. The customer shall supply the data within 30 days of the Telephone Company request. The customer shall keep records of call detail from which the percentage of interstate and intrastate use can be ascertained and upon request of the Telephone Company make the records available for inspection as reasonably necessary for purposes of verification of the percentages. Requests for verification shall be limited to no more than one per year, except in extreme circumstances. Audits may be conducted by independent auditors if the Telephone Company and the customer or the customer alone is willing to pay the expenses of the audit.

x Issued under authority of Special Permission No. 97-30.

(TR1051)

(This page filed under Transmittal No. 1051)

Issued: January 12, 1997

Effective: January 27, 1997

Four AT&T Plaza, Dallas, Texas 75202

2. General Regulations (Cont'd)

2.3 Obligations of the Customer (Cont'd)

2.3.11 Determination of Interstate Charges for Mixed Interstate and Intrastate Access Service

When mixed interstate and intrastate Access Service is provided, all charges (i.e., nonrecurring, monthly and/or usage) including optional features charges, will be prorated between interstate and intrastate. The Percentage for Interstate Use PIU(s) reported as set forth in 2.3.10, preceding, will serve as the basis for prorating the charges. The percentage of an Access Service to be charged as interstate is applied in the following manner:

(T)

(A) For monthly and nonrecurring chargeable rate elements

- (1) Switched Access Services Except Direct-Trunk Transport Facilities or Entrance Facilities

Multiply the general PIU or the residual PIU, if the customer has chosen to provide usage type PIUs, times the quantity of chargeable elements times the stated tariff rate per element. For elements of Feature Group B or D Switched Access Service which are billed at the tandem level, the tandem routed PIU set forth in Section 2.3.10 (F) shall apply.

(D)

- (2) Direct-Trunked Transport Facilities and Entrance Facilities

Multiply the Direct-Trunked Transport Facility or Entrance Facility PIU, times the quantity of chargeable elements times the stated tariff rate per element.)

(This page filed under Transmittal No. 1801)

2. General Regulations (Cont'd)

2.3 Obligations of the Customer (Cont'd)

2.3.11 Determination of Interstate Charges for Mixed Interstate and Intrastate Access Service (Cont'd)

- (B) For all Switched Access Services usage sensitive chargeable rate elements:
- (1) If the actual jurisdiction of the usage can identified, multiply the actual measured use which is identified as interstate times the stated tariff rate.
 - (2) If the customer has chosen to provide one general PIU for all usage types, then multiply the general PIU times actual usage (i.e., measured or Telephone Company assumed average usage) which cannot be jurisdictionally identified times the stated tariff rate. If the customer has chosen to provide separate usage type PIUs and the residual PIU, then multiply the usage type PIU or the residual PIU times the corresponding actual usage type minutes of use (i.e., 900 originating PIU times 900 originating usage) times the stated tariff rate.
 - (3) For usage sensitive optional features, if the customer has chosen to provide one general PIU, then multiply the general PIU times the actual usage of the optional feature times the stated tariff rate. If the customer has chosen to provide separate usage type PIUs and the residual PIU, then multiply the residual PIU times the actual usage of the optional feature times the stated tariff rate.)

Certain material previously on this page now appears on Original Page 39.1.1.
Certain material on this page previously appeared on 4th Revised Page 39.

(TR721)

(This page filed under Transmittal No. 721)

2. General Regulations (Cont'd)

2.3 Obligations of the Customer (Cont'd)

2.3.12 Certification of Special Access Services As Interstate

(A) Determination of Jurisdiction of Special Access and Specialized Network Services

C
C

Jurisdiction refers to the classification of a service as interstate (subject to the jurisdiction of the Federal Communications Commission) or as intrastate (subject to the jurisdiction of a state regulatory body).

Pursuant to the Decision and Order by the Federal Communications Commission in CC Dockets No. 78-72 and 80-286, released July 20, 1989, jurisdiction of a Special Access Service will be determined as follows:

- (1) If the customer determines that the interstate traffic on the service involved constitutes ten percent (10%) or less of the total traffic on that service, the service will be provided in accordance with the applicable rules and regulations of the appropriate intrastate tariff
- (2) If the customer determines that the interstate traffic on the service involved constitutes more than ten percent (10%) of the total traffic on that service, the service will be provided in accordance with the applicable rules and regulations of this Tariff.

(B) Jurisdictional Use Certification Requirement

C

When a customer orders a Special Access or Specialized Network Services from this tariff, the customer shall certify in its order that the Special Access or Specialized Network Service meets the requirements for classification as interstate.

C

Customers will be requested to certify each Special Access or Special Access DNAL service in effect or ordered prior to May 15, 1990, and advise the Telephone Company of any changes in jurisdiction. For changes in jurisdiction of existing services requested between May 15, 1990 and August 15, 1990, application of the Administrative Charge set forth in 7.4.1(c)(6) and Optional Payment Plan termination Charges set forth in 7.4.9 following, are waived

(TR939)

(This page filed under Transmittal No. 937)

2. General Regulations (Cont'd)

2.3 Obligations of the Customer (Cont'd)

2.3.12 Certification of Special Access Services As Interstate

(C) Verification Information

If a billing dispute arises or a regulatory commission questions the interstate classification of the Special Access Service, the Telephone Company will ask the customer to provide the data the customer uses to determine that interstate usage is greater than ten percent. The customer shall keep records of system design and functions from which the percentages of interstate and intrastate usage (and hence jurisdiction) can be ascertained. The customer shall supply the data within 30 days of the Telephone Company request.

2.3.13 Metropolitan Statistical Area Access Services

For the Metropolitan Statistical Areas (MSAs) in which the Telephone Company has received Phase II pricing flexibility, pursuant to Subpart H of Part 69 of the Commission's Rules. Section 21 of this Tariff governs the offering of service in these MSA's. Upon approval of Phase II pricing flexibility for a petitioned MSA, services purchased pursuant to Sections 6, 7, 26 and 27 under the various Pricing Plans as identified in Section 21.4(F), will then become subject to the rates in Section 21, Metropolitan Statistical Area Access Services.

2.3.14 VoIP – PSTN Traffic

This Section applies to VoIP-PSTN Traffic exchanged between the Telephone Company and the Customer in time division multiplexing ("TDM") format that originates and/or terminates in Internet protocol ("IP") format. VoIP-PSTN traffic originates and/or terminates in IP format if it originates from and/or terminates to an end-user Customer of a service that requires Internet protocol-compatible Customer premises equipment. The Switched Access rate elements in this tariff for both usage and facilities apply to any VoIP-PSTN traffic.

(N)
 |
 (N)

(This page filed under Transmittal No. 1757)

2. General Regulations (Cont'd)

2.4 Payment Arrangements and Credit Allowances

2.4.1 Payment of Rates, Charges and Deposits

(D)

(D)

(This page filed under Transmittal No. 1449)

2. General Regulations (Cont'd)

2.4 Payment Arrangements and Credit Allowances

2.4.1 Payment of Rates, Charges and Deposits

To protect itself from the risk of non-payment, the Telephone Company may require a customer to provide a cash deposit in those instances specified in 2.4.1(A) below.

(A) There is a proven history of late payments or the customer has not demonstrated established credit. A proven history of late payments is defined as 2 or more occasions within the preceding 12 months in which payment(s) for the undisputed charges of that month's total billings (sum of all bills sent in that month for all accounts for all services provided under this tariff by the Telephone Company) was

- (1) not received within 3 business days following the payment due date and
- (2) the payment(s) not received within 3 business days represented at least 10% of the month's total billings for all accounts for all services provided under this tariff by the Telephone Company.

Example for January 2005 billings:

Assume:

\$100 payment for a January billing received on the due date
\$100 payment for a January billing received 1 business day late
\$100 payment for a January billing received 4 business days late

Total January billings for all accounts for all services provided under this tariff by the Telephone Company sum to \$300. There are no disputes.

One payment is recognized as being late since it is beyond 3 business days late and it represents 33% of the monthly billings. This would represent the first occasion of a monthly late payment.

Disputed billed amounts for the sake of this section are disputed via the process outlined in 2.4.1(B)(3)(c), (d), (e), and (f).

In the event that a customer has a history of late payments or has not demonstrated established credit, the Telephone Company may require the customer to pay a two-month deposit based on the total charges billed and rendered by the Telephone Company for the most recent two months of service. In the event the customer has not received two months of service from the Telephone Company, the two-month deposit will be based on charges estimated by the Telephone Company for the initial two-month period.

(This page filed under Transmittal No. 1449)

2. General Regulations (Cont'd)

2.4 Payment Arrangements and Credit Allowances (Cont'd)

2.4.1 Payment of Rates, Charges and Deposits (Cont'd)

(A) (Cont'd)

The Telephone Company will provide the customer written notice by Overnight Delivery as described in 2.1.8(A) if a deposit is required under this section. The customer must pay the two-month deposit within 15 business days following the date the written notice is sent to the customer. Such notice period will begin the day after the notice is sent. If the customer fails to pay the deposit by the due date, as described above, the Telephone Company may send the customer a written notice by Overnight Delivery stating that if the deposit is not received within 15 calendar days of the original deposit due date, the Telephone Company may take any or all of the actions specified in Section 2.1.8(A).

Simple interest at a rate set forth in (B)(3)(b)(i) or in (B)(3)(b)(ii) following, whichever is lower, will accrue on cash deposits. Simple interest will be applied for the number of days from the date the customer deposit is received by the Telephone Company to and including the date such deposit is credited to the customer's account or the date the deposit is refunded by the Telephone Company.

The cash deposit will be returned, with any accrued, uncredited interest within 15 business days of when a customer with a history of late payments or no established credit history demonstrates a one-year prompt payment record (undisputed billed balances are paid within the bill payment requirements outlined in 2.4.1(B)(3)(a)).

In the event the provision of all service to the customer is terminated and the Telephone Company maintains a cash deposit from the customer, the deposit and any accrued, uncredited interest will be applied to any outstanding sums owed to the Telephone Company, and any remaining balance will be returned to the customer.

(N)

(N)

(This page filed under Transmittal No. 1449)

(x)

(x)

x Issued under authority of Special Permission No. 03-002 of the F.C.C. in order to withdraw material filed under Transmittal No. 1312 without becoming effective.

(This page filed under Transmittal No. 1328)

Issued: December 30, 2002

Effective: January 14, 2003

Four AT&T Plaza, Dallas, Texas 75202

(x)

x Issued under authority of Special Permission No. 03-002 of the F.C.C. in order to withdraw material filed under Transmittal No. 1312 without becoming effective.

(x)

(This page filed under Transmittal No. 1328)

Issued: December 30, 2002

Effective: January 14, 2003

Four AT&T Plaza, Dallas, Texas 75202

2. General Regulations (Cont'd)

2.4 Payment Arrangements and Credit Allowances (Cont'd)

2.4.1 Payment of Rates, Charges and Deposits (Cont'd)

(B) The Telephone Company shall bill on a current basis all charges incurred by and credits due to the customer under this tariff attributable to services, including, but not limited to, Maintenance of Service as set forth in 13.3.1 following, established or discontinued during the preceding billing period. In addition, the Telephone Company shall bill in advance charges for all services to be provided during the ensuing billing period except for charges associated with service usage and for the following which will be billed in arrears:

- the Federal Government Service
- End User Service in the Illinois Exchanges of,
 - Belleville
 - East St. Louis
 - Edgemont
 - Granite City

The bill day (i.e., the billing date of a bill for a customer for Access Service under this tariff), the period of service each bill covers and the payment due date will be as follows:

For End User Access Service and Presubscription charges billed to an end

user, the Telephone Company will establish a bill day each month for each End

User account. The bill will cover End User Access Service charges for the ensuing billing period except in the Illinois Exchanges of Belleville, East St. Louis, Edgemont and Granite City or End User Access Service for the Federal Government which will be billed in arrears. Any applicable presubscription charges, any known unbilled charges for prior periods and any known unbilled adjustments for prior periods for End User Access Service and Presubscription Service will be applied to this bill. Such bills are due when rendered.

T

T

For service other than End User Access Service and Presubscription charges billed

to an end user the Telephone Company will establish a bill day each month for each

customer account. The bill will cover nonusage sensitive service charges for the ensuing billing period for which the bill is rendered, any known unbilled nonusage sensitive charges for prior periods and unbilled usage charges for the period after the last bill day through the current bill day. Any known unbilled usage charges for prior periods and any known unbilled adjustments will be applied to this bill. Payment for bills is due as set forth in (3) following. If payment is not received by the payment date, as set forth in (3) following in immediately available funds, a late payment penalty will apply as set forth in (3) following.

T

T

(TR1155)

(This page filed under Transmittal No. 1155)

2. General Regulations (Cont'd)

2.4 Payment Arrangements and Credit Allowances (Cont'd)

2.4.1 Payment of Rates, Charges and Deposits (Cont'd)

(B) (Cont'd)

(1) Exception: In the Illinois Operating Company a late payment charge of 1.5 percent per month shall apply to End User Service and Presubscription Service charges shown on a monthly bill which remains unpaid after the due date except that the charge is not applicable as specified in 2.4.1 (B)(1)(b) following.

T

(a) The late payment charge will be waived for residential customers once in each calendar year.

(b) This charge does not apply to:

- amounts which are in dispute at the time the late payment charge would otherwise be applied
- federal excise tax or any other taxes levied by law directly on the customer
- accounts of the federal, state, county or local government.

(2) Exception: In the Michigan Operating Company a late payment charge of 1.5 percent per month shall apply to End User Service and Presubscription Service charges shown on a monthly bill for business class of services which remain unpaid after the due date except that the charge is not applicable as specified in 2.4.1(B)(2)(a) following.

N

(a) This charge does not apply to:

- amounts which are in dispute at the time the late payment charge would otherwise be applied
- federal excise tax or any other taxes levied by law directly on the customer
- accounts of the federal, state, county or local government.

N

Certain material previously on this page now appears on 3rd Revised Page 41.

(TR975)

(This page filed under Transmittal No. 975)

ACCESS SERVICE

2. General Regulations (Cont'd)

Dx

Dx

(This page filed under Transmittal No. 685)

Issued: December 7, 1992

Effective: December 22, 1992

Four AT&T Plaza, Dallas, Texas 75202

2. General Regulations (Cont'd)

2.4 Payment Arrangements and Credit Allowances (Cont'd)

2.4.1 Payment of Rates, Charges and Deposits (Cont'd)

(B) (Cont'd)

- (3) (a) All bills dated as set forth in (2) preceding for service, other than End User Access Service and Presubscription charges billed to the end user provided to the customer by the Telephone Company, are due 31 days (payment date) after the bill day or by the next bill date (i.e., same date in the following month as the bill date) whichever is the shortest interval, except as provided herein, and are payable in immediately available funds. If such payment date would cause payment to be due on a Saturday, Sunday or Holiday (i.e., New Year's Day, Independence Day, Labor Day, Thanksgiving Day, Christmas Day, and a day when Martin Luther King Day, Washington's Birthday, Memorial Day, Columbus Day and Veterans Day are legally observed), payment for such bills will be due from the customer as follows:

If such payment date falls on a Sunday or on a Holiday which is observed on a Monday, the payment date shall be the first non-Holiday day following such Sunday or Holiday. If such payment date falls on a Saturday or on a Holiday which is observed on Tuesday, Wednesday, Thursday or Friday, the payment date shall be the last non-Holiday day preceding such Saturday or Holiday.

- (b) Further, if any portion of the payment is received by the Telephone Company after the payment date as set forth in (a) preceding, or if any portion of the payment is received by the Telephone Company in funds which are not immediately available to the Telephone Company, then a late payment penalty shall be due to the Telephone Company. The late payment penalty shall be the portion of the payment not received by the payment date times a late factor. The late factor shall be the lesser of:
- (i) the highest interest rate (in decimal value) which may be levied by law for commercial transactions, applied on a simple interest basis for the number of days from the payment due date to and including the date that the customer actually makes the payment to the Telephone Company, or

(This page filed under Transmittal No. 1155)

2. General Regulations (Cont'd)

2.4 Payment Arrangements and Credit Allowances (Cont'd)

2.4.1 Payment of Rates, Charges and Deposits (Cont'd)

(B) (Cont'd)

(3) (Cont'd)

(b) (Cont'd)

(ii) 0.000493 per day, (annual percentage rate of 18.0% applied on a simple interest basis for the number of days from the payment date to and including the date that the customer actually makes the payment to the Telephone Company.

(c) In the event that a billing dispute occurs concerning any charges billed to the customer by the Telephone Company the following regulations will apply.

- (1) A good faith dispute requires the customer to provide a written claim to the Telephone Company. Instructions for submitting a dispute can be obtained by calling the billing inquiry number shown on the customer's bill. Such claim must identify in detail the basis for the dispute, the account number under which the bill has been rendered, the date of the bill and the specific items on the bill being disputed, to permit the Telephone Company to investigate the merits of the dispute.
- (2) The date of the dispute shall be the date on which the customer furnishes the Telephone Company the account information required by Section 2.4.1(B)(3)(c)(1) above.
- (3) The date of resolution shall be the date on which the Telephone Company completes its investigation of the dispute, notifies the customer in writing of the disposition and, if the billing dispute is resolved in favor of the customer, applies the credit for the amount of the dispute resolved in the customer's favor to the customer's bill.
- (4) If the dispute is decided to be in favor of the Telephone company, then the resolution date will be the date upon which a written decision on this dispute is sent to the customer.

(T)
(T)
(D)

(D)
(N)

(N)
(D)
(D)
(D)

(This page filed under Transmittal No. 1449)

2. General Regulations (Cont'd)

2.4 Payment Arrangements and Credit Allowances (Cont'd)

2.4.1 Payment of Rates, Charges and Deposits (Cont'd)

(B) (Cont'd)

(3) (Cont'd)

- (d) If a customer has overpaid because of a billing error, a refund in the amount of the overpayment will be made to the customer. For service other than End User Access Service and Presubscription, if a claim for a refund pertaining to the overpayment was submitted by the customer within six months of the payment date, interest on the refund will be paid to the customer from the date of the overpayment to and including the date on which the refund is made to the customer. The interest rate will be 0.000493 per day (annual percentage rate of 18.0%), applied on a simple interest basis. Refunds will be made by crediting the customer's account.

C

(This page filed under Transmittal No. 182)

2. General Regulations (Cont'd)

2.4 Payment Arrangements and Credit Allowances (Cont'd)

2.4.1 Payment of Rates, Charges and Deposits (Cont'd)

(B) (Cont'd)

(3) (Cont'd)

(e) The late payment penalty, specified in (b) above, shall not apply for the first 90 days after the bill date for the unpaid monthly recurring charges associated with accounts containing Entrance Facilities or Direct Transport services when the bill date is between December 30, 1993 and March 29, 1994. A late payment penalty will apply for any unpaid charges not received within 90 days after the bill date for accounts containing Entrance Facilities or Direct Transport services.

The late payment penalty will be the portion of the unpaid charges not received within 90 days after the bill date times a late factor. The late factor will be calculated in the same manner as set forth in (b) above, except that the number of days applied against the rate specified in (b) will be number of days from the 90th day after the bill date to and including the date that the customer actually makes the payment to the Telephone Company.

(f) If the customer disputes monthly recurring charges assessed on a bill with a bill date between December 30, 1993 and March 29, 1994 for accounts containing Entrance Facilities or Direct Transport services, and pays the undisputed amount on or before the payment date, any late payment charge for the disputed amount will not start until 90 days after the bill date. The late payment charge is only applicable when the dispute is resolved in favor of the Telephone Company.

Sy
||
Sy
Z
Sy
Sy
Sy
||
Sy

All material on this page expires at the end of June 29, 1994 unless sooner canceled, changed or extended.

y Material filed February 14, 1994 in Transmittal No. 776 under authority of Special Permission No. 94-193.

(TR780)

(This page filed under Transmittal No. 780)

2. General Regulations (Cont'd)

2.4 Payment Arrangements and Credit Allowances (Cont'd)

2.4.1 Payment of Rates, Charges and Deposits (Cont'd)

- (C) Adjustments for the quantities of services established or discontinued in any billing period beyond the minimum period set forth for services in other sections of this tariff will be prorated to the number of days or major fraction of days based on a 30 day month. The Telephone Company will, upon request and if available, furnish such detailed information as may reasonably be required for verification of any bill.

Dx

Tx

x Issued under authority of Special Permission No. 97-255.

(TR1119)

(This page filed under Transmittal No. 1119)

2. General Regulations (Cont'd)

2.4 Payment Arrangements and Credit Allowances (Cont'd)

2.4.1 Payment of Rates, Charges and Deposits (Cont'd)

- (D) When a rate as set forth in this tariff is shown to more than two decimal places, the charges will be determined using the rate shown. The resulting amount will be rounded to the nearest penny (i.e., rounded to two decimal places).
- (E) When more than one copy of a customer's bill for services provided under the provisions of this tariff is furnished to the customer, an additional charge applies for each additional copy of the bill as set forth in 13.3.5 following.

T

2.4.2 Minimum Periods

The minimum period for which services are provided and for which rates and charges are applicable is one month except for those services set forth in 5.2.5(B) and (D), 6.8.3, 7.4.5, 9.4.1, 9.8.5, 11.2.4 and 13.3.4(C)(1)(b), (c) and (d) following.

When a service is discontinued prior to the expiration of the minimum period, charges are applicable, whether the service is used or not, as follows:

- (A) When a service with a one month minimum period is discontinued prior to the expiration of the minimum period, a one month charge will apply at the rate level in effect at the time service is discontinued.
- (B) When a service with a minimum period greater than one month is discontinued prior to the expiration of the minimum period, the applicable charge will be the lesser of (1) the Telephone Company's total nonrecoverable costs less the net salvage value for the discontinued service or (2) the total monthly charges, at the rate level in effect at the time service is discontinued, for the remainder of the minimum period, unless otherwise specified under the terms of an Individual Case Basis filing, or Optional Payment Plan.

2.4.3 Cancellation of an Order for Service

Provisions for the cancellation of an Access Order or Planned Facilities order for Switched Access or Special Access service are set forth in 5.2.2(B), 5.2.3 and 5.4.5 following

x Issued under authority of Special Permission No. 97-255.

(TR1119)

(This page filed under Transmittal No. 1119)

2. General Regulations (Cont'd)

2.4 Payment Arrangements and Credit Allowances (Cont'd)

2.4.4 Credit Allowance for Service Interruptions

(A) General

A service is interrupted when it becomes unusable to the customer because of a failure of a facility component used to furnish service under this tariff or in the event that the protective controls applied by the Telephone Company result in the complete loss of service by the customer as set forth in 6.6.1 following, except as specified in 2.4.4(B)(9) following. An interruption period starts when an inoperative service is reported to the Telephone Company, and ends when the service is operative.

(B) When a Credit Allowance Applies

In case of an interruption to any service, allowance for the period of interruption, if not due to the negligence of the customer or the customer's end user shall be as follows:

- (1) For Special Access Services, except as specified in 2.4.4(B)(2), 2.4.4(B)(10), 2.4.4(B)(12), 2.4.4(B)(13) and 2.4.4(B)(16) following, no credit shall be allowed for an interruption of less than 30 minutes. The customer shall be credited for an interruption of 30 minutes or more at the rate of 1/1440 of the monthly charges for the facility or service for each period of 30 minutes or major fraction thereof that the interruption continues for all services except those as described in Section 2.4.4(B)(2), 2.4.4(B)(9), 2.4.4(B)(10), 2.4.4(B)(12), 2.4.4(B)(13) and 2.4.4(B)(16) following. The Telephone Company may require joint out of service testing between the customer and the Telephone Company for investigation and correction of the interruption. (T)

For Network Reconfiguration Service (NRS), no credit shall be allowed for interruptions required to perform preventative or routine maintenance, or to perform software updates when the customer has been notified at least 24 hours prior to such occurrences.

The monthly charges used to determine the credit shall be as follows:

- (a) For two-point services, the monthly charge shall be the total of all the monthly rate element charges associated with the service (i.e., two Local Distribution Channels, Channel Mileage Terminations and Channel Mileage as appropriate, and optional feature and functions). (T)

(This page filed under Transmittal No. 1388)

2. General Regulations (Cont'd)

2.4 Payment Arrangements and Credit Allowances (Cont'd)

2.4.4 Credit Allowance for Service Interruptions (Cont'd)

(B) When a Credit Allowance Applies (Cont'd)

- (b) For multipoint services and Special Access Services associated with Network Reconfiguration Service (NRS), the monthly charge shall be only the total of all the monthly rate element charges associated with the portion of the service that is inoperative (i.e., a Local Distribution Channel per customer premises, Channel Mileage Terminations and Channel Mileage as appropriate, and optional features and functions).

(T)

(This page filed under Transmittal No. 1357)

2. General Regulations (Cont'd)

2.4 Payment Arrangements and Credit Allowances (Cont'd)

2.4.4 Credit Allowance for Service Interruptions (Cont'd)

(B) When a Credit Allowance Applies (Cont'd)

(1) (Cont'd)

- (c) For multiplexed services, the monthly charge shall be the total of all the monthly rate element charges associated with the portion of the service that is inoperative. When the higher capacity facility which is multiplexed or the multiplexer itself is inoperative, the monthly charge shall be the total of all the monthly rate element charges associated with the higher capacity facility from the customer's premises to the hub (i.e., the Local Distribution Channel, Channel Mileage Terminations and Channel Mileage as appropriate, and optional features and functions, including the multiplexer). When the lower capacity service which rides a channel of the multiplexed lower capacity facility is inoperative, the monthly charge shall be the total of all the monthly rate element charges associated with the lower capacity service from the Hub to a customer premises (i.e., Local Distribution Channel, Channel Mileage Terminations and Channel Mileage, as appropriate, and optional features and functions.

For DS3 service provided under a Shared Facility Credit/Shared Facility Channel Service arrangement, the monthly charge shall be the total of all the monthly rate element charges, less any applicable Shared Facility Credits, associated with the portion of the service that is inoperative.

- (2)* For Program Audio and Video Special Access Services, no credit shall be allowed for an interruption of less than 30 seconds. The customer shall be credited for an interruption of 30 seconds or more as follows: (C)
- (a) For two-point services, when monthly rates are applicable, the credit shall be at the rate of 1/8640 of the monthly charges for the service for each period of 5 minutes or major fraction thereof that the interruption continues.
- (b) For two-point services, when daily rates are applicable, the credit shall be at the rate of 1/288 of the daily charges for the service for each period of 5 minutes or major fraction thereof that the interruption continues.

* Effective April 1, 2004, this regulation is limited to existing customers at existing locations. Additionally, this regulation is limited to services that may be rearranged or moved pursuant to existing OPP terms and conditions found in Section 7.4.10. (N)
(N)
(N)

(This page filed under Transmittal No. 1388)

2. General Regulations (Cont'd)

2.4 Payment Arrangements and Credit Allowances (Cont'd)

2.4.4 Credit Allowance for Service Interruptions (Cont'd)

(B) When A Credit Allowance Applies (Cont'd)

(2)* (Cont'd)

- (c) For multipoint services, when monthly rates are applicable, the credit shall be at the rate of 1/8640 of the monthly charges for all Local Distribution Channels, Channel Mileage Terminations and Channel Mileage, and optional features and functions that are inoperative for each period of 5 minutes or major fraction thereof that the interruption continues. (C)
- (d) For multipoint services, when daily rates are applicable, the credit shall be at the daily rate of 1/288 of the daily charges for all Local Distribution Channels, Channel Mileage Terminations and Channel Mileage, and optional features and functions that are inoperative for each period of 5 minutes or major fraction thereof that the interruption continues.
- (e) For multipoint services, the credit for the monthly or daily charges includes the charges for the distribution amplifier only when the distribution amplifier is inoperative.
- (f) When two or more interruptions occur during a period of 5 consecutive minutes, such multiple interruptions shall be considered as one interruption.
- (3) For Switched Access Service, except as described in (9), (10) (13), (14) and (15) following, Directory Assistance Service, and Ameritech Directory Search Service, no credit shall be allowed for an interruption of less than 24 hours. The customer shall be credited for an interruption of 24 hours or more at the rate of 1/30 of (a) the applicable monthly rates or (b) any charge based on assumed minutes of use or (c) the minimum monthly usage charge for each period of 24 hours or major fraction thereof that the interruption continues. However, in no case is a credit allowance applicable when the actual usage charge exceeds the minimum monthly usage charge in any one monthly billing period. (T)
(T)

When Switched Access traffic is diverted from a direct trunked facility as a result of a service interruption, the direct trunked facility will be credited as described in 2.4.4.(B)(9) or 2.4.4(B)(10) following.

* Effective April 1, 2004, this regulation is limited to existing customers at existing locations. Additionally, this regulation is limited to services that may be rearranged or moved pursuant to existing OPP terms and conditions found in Section 7.4.10.

(N)
(N)
(N)

(This page filed under Transmittal No. 1388)

ACCESS SERVICE

2. General Regulations (Cont'd)

2.4 Payment Arrangements and Credit Allowances (Cont'd)

2.4.4 Credit Allowance for Service Interruptions (Cont'd)

(B) When A Credit Allowance Applies (Cont'd)

- (4) For all other services, to include End User Common Line charges, no credit shall be allowed for an interruption of less than 24 hours. The customer shall be credited for an interruption of 24 hours or more at the rate of 1/30 of (a) the applicable monthly rates or (b) any charge based on assumed minutes of use or (c) the minimum monthly usage charge for each period of 24 hours or major infraction thereof that the interruption continues. In no case is a credit allowance applicable when the actual usage charge exceeds the minimum monthly usage charge in any one monthly billing period.
- (5) The credit allowance(s) for service interruptions shall not exceed applicable (a) monthly rates or (b) charges for assumed minutes of use or (c) the minimum monthly usage charge for the service interrupted in any one monthly billing period.
- (6) For certain Special Access services (WD1-3; DS1 Service, HC1; DS3 Service, HC3; ⁽¹⁾ and SONET Xpress), the period during which the error performance is below that specified for the service will be considered as an interruption. (D)
- (7) For multiplexed service ordered under the Shared Network Arrangement, the host subscriber, as well as each service user, must notify the Telephone Company of any service outage in order to receive their portion of the credit allowance.
- (8) Service Interruptions for Specialized Service or Arrangements provided under the provisions of Section 12 shall be administered in the same manner as those set forth in this Section 2.4.4, unless other regulations are specified with the individual case filing. (D)
(T)

⁽¹⁾ Material in this Section has been de-tariffed as required by the Commission upon use of the forbearance relief pursuant to FCC Memorandum Opinion and Order No. 07-180, released October 12, 2007. Terms and Conditions associated with de-tariffed services are available at www.att.com/guidebook.

(This page filed under Transmittal No. 1818)

2. General Regulations (Cont'd)

2.4 Payment Arrangements and Credit Allowances (Cont'd)

2.4.4 Credit Allowance for Service Interruptions (Cont'd)

(B) When a Credit Allowance Applies (Cont'd)

(9)* For Special Access Metallic, Telegraph, Direct Analog and Base Rate Service Local Distribution Channels, Channel Mileage Terminations and Channel Mileage and Switched Access Voice Grade Service Entrance Facilities and Direct Transport Channel Mileage Termination and Channel Mileage, except as specified in 2.4.4(B)(12) following, no credit shall be allowed for an interruption period of less than 30 minutes. An interruption period starts when an inoperative service is released by the customer to the Telephone Company for testing/repair and ends when the service is operative. The customer must make the circuit available for testing by the Telephone Company and provide access as needed. Suspension of the calculated interruption period will occur when access to the customer premises can not be gained or the customer does not release the circuit experiencing trouble.

(C)

In any month, as a result of the interruption, the total credit per rate element of the interrupted service may not exceed 100 percent of the monthly charge for that particular rate element.

Credit Allowance Schedule

Interruption Period		Applicable Credit	
More than 30 minutes, but less than 2 hours		1/1440th per 30 minute Interval	
Interruption Period	Credit Per Interruption	Interruption Period	Credit Per Interruption
2 Hours to 4 Hours		Over 4 Hours	
Metallic		Metallic	
- LDC	\$4.30	- LDC	\$8.60
- CM	2.25	- CM	4.50
Telegraph		Telegraph	
- LDC		- LDC	
- 2 Wire	7.90	- 2 Wire	15.80
- 4 Wire	9.00	- 4 Wire	18.00
- CMT	3.60	- CMT	7.20
- CM	.30	- CM	.60

minute

or 1/1440 per 30

interval, whichever is greater

* Effective April 1, 2004, this regulation is limited to existing customers at existing locations. Additionally, this regulation is limited to services that may be rearranged or moved pursuant to existing OPP terms and conditions found in Section 7.4.10.

(N)
(N)
(N)

(This page filed under Transmittal No. 1388)

2. General Regulations (Cont'd)

2.4 Payment Arrangements and Credit Allowances (Cont'd)

2.4.4 Credit Allowance for Service Interruptions (Cont'd)

(B) When a Credit Allowance Applies (Cont'd)

(9)* (Cont'd)

Interruption Period		Applicable Credit		
More than 30 minutes, but less than 2 hours		1/1440th per 30 minute Interval		(C)
Interruption Period	Credit Per Interruption	Interruption Period	Credit Per Interruption	
2 Hours to 4 Hours Direct Analog		Over 4 Hours		
- LDC		- LDC		
- 2 Wire	\$5.45	- 2 Wire	\$10.90	
- 4 Wire	8.85	- 4 Wire	17.70	
- CMT	3.15	- CMT	6.30	
- CM	.25	- CM	.50	
Base Rate		Base Rate		
- LDC	16.60	- LDC	33.20	
- CMT	2.75	- CMT	5.50	
- CM	.25	- CM	.50	
Entrance Facilities		Entrance Facilities		
- Voice Grade		- Voice Grade		
- 2 Wire	5.75	- 2 Wire	11.50	
- 4 Wire	9.30	- 4 Wire	18.65	
Direct Transport		Direct Transport		
- CMT		- CMT		
- Voice Grade	3.30	- Voice Grade	6.60	
- CM		- CM		
- Voice Grade	.25	- Voice Grade	.50	
		or 1/1440 per 30 minute interval, whichever is greater		

* Effective April 1, 2004, This regulation is limited to existing customers at existing locations. Additionally, this regulation is limited to services that may be rearranged or moved pursuant to existing OPP terms and conditions found in Section 7.4.10.

(N)
 (N)
 (N)

(This page filed under Transmittal No. 1388)

2. General Regulations (Cont'd)

2.4 Payment Arrangements and Credit Allowances (Cont'd)

2.4.4 Credit Allowance for Service Interruptions (Cont'd)

(B) When a Credit Allowance* Applies (Cont'd)

(10)¹ For Special Access DS1 and DS3 Service Local Distribution Channels, Channel Mileage Terminations and Channel Mileage and Switched Access LT1 and LT3 Service Entrance Facilities and Direct Transport Channel Mileage Terminations and Channel Mileage, the customer shall be credited when the service experiences a verifiable interruption of 1 (one) minute or more. A service interruption must be reported to the Telephone Company within 24 hours of the interruption. An interruption period starts when an inoperative service is reported by the customer to the Telephone Company for repair and ends when the service is operative. The customer must make the circuit available for testing by the Telephone Company and provide access as needed. Suspension of the calculated interruption period will occur when access to the customer premises can not be gained or the customer does not release the circuit experiencing trouble. Credit allowance for service interruptions of 1 (one) minute or more will be based on the rate zone assignment of the customer's serving wire center, as specified in Sections 6.8.1 or 7.4.1 following. For Local Distribution Channels, Entrance Facilities, Channel Mileage Terminations and Channel Mileage assigned to rate zone 1, rate zone 2 or rate zone 3 wire centers, the customer shall be credited with 100 (one hundred) percent of the monthly rates for service interruptions of 1 (one) minute or more. For Local Distribution Channels, Entrance Facilities, Channel Mileage Terminations and Channel Mileage assigned to rate zone 4 or rate zone 5 wire centers, the customer shall be credited for service interruptions of more than 1 (one) minute but less than 2 (two) hours based on the following schedule. For service interruptions of more than 2 hours, the customer shall be credited with 100 percent of the monthly rate.

(C)

In any month, as a result of the interruption, the total credit per rate element of the interrupted service may not exceed 100 percent of the monthly charge for that particular rate element.

Credit allowance for service interruptions for DS3 Local Distribution Channels with an Electrical Interface and LT-3 Entrance Facilities with an Electrical Interface in rate zone 1, rate zone 2 and rate zone 3 wire centers and service interruptions of more than 2 hours in rate zone 4 and 5 wire centers will be calculated after application of Volume Pricing Plan discounts as described in 6.8.2(D)(6)(g) and 7.4.10 I following.

¹ Effective April , 2004, this regulation is limited to existing customers at existing locations. Additionally, this regulation is limited to services that may be rearranged or moved pursuant to existing OPP terms and conditions found in Section 7.4.10.

* Credit allowances are not available for Optical Services associated with the DS3 Service Package, DS3 Service Channel and Entrance Facilities LT-3 subscribed to, on or after March 8, 2001.

(N)
 (N)
 (N)

(This page filed under Transmittal No. 1388)

2. General Regulations (Cont'd)

2.4 Payment Arrangements and Credit Allowances (Cont'd)

2.4.4 Credit Allowance for Service Interruptions (Cont'd)

(B) When a Credit Allowance Applies (Cont'd)

(10)¹ (Cont'd)

Credit Allowance Schedule
 Rate Zone 4 and Rate Zone 5 Wire Centers

(C)

Credit Per Credit Per
Interruption PeriodInterruptionInterruption PeriodInterruption

1 Minute to 1 Hour		1 Hour to 2 Hours	
DS1 LDC	\$19.83	DS1 LDC	\$ 39.67
DS1 CMT	8.12	DS1 CMT	16.23
DS1 CM	2.32	DS1 CM	4.63
DS3 LDC (EI)	173.33	DS3 LDC (EI)	346.67
DS3 Srv Pkg (Opt)*	750.00	DS3 Srv Pkg (Opt)*	1500.00
DS3 Srv Chnl (Opt)*	75.00	DS3 Srv Chnl (Opt)*	150.00
DS3 CMT	53.67	DS3 CMT	107.33
DS3 CM	8.00	DS3 CM	16.00
Entrance Facilities		Entrance Facilities	
- LT 1	11.67	- LT 1	23.33
- LT 3 Electrical	216.67	- LT 3 Electrical	433.33
- LT 3 Optical*	525.00	- LT 3 Optical*	1050.00
Direct Transport		Direct Transport	
CMT		CMT	
- LT 1	2.02	- LT 1	4.03
- LT 3	21.00	- LT 3	42.00
CM		CM	
- LT 1	.83	- LT 1	1.67
- LT 3	3.33	- LT 3	6.67

¹ Effective April 1, 2004, this regulation is limited to existing customers at existing locations. Additionally, this regulation is limited to services that may be rearranged or moved pursuant to existing OPP terms and conditions found in Section 7.4.10.

* Credit allowances are not available for Optical Services associated with the DS3 Service Package, DS3 Service Channel and Entrance Facilities LT-3 subscribed to, on or after March 8, 2001.

(N)
 (N)
 (N)

(This page filed under Transmittal No. 1388)

2. General Regulations (Cont'd)

2.4 Payment Arrangements and Credit Allowances (Cont'd)

2.4.4 Credit Allowance for Service Interruptions (Cont'd)

(B) When a Credit Allowance Applies (Cont'd)

(11) For Special Access Metallic, Telegraph, Program Audio, Video, Direct Analog, Base Rate, DS1 and DS3 Service and Switched Access Voice Grade Service, LT1 and LT3 Service Entrance Facilities and Direct Transport, no credit shall be allowed for interruptions less than 30 minutes. For interruptions of 30 minutes or more but less than 4 hours, the customer shall be credited at the rate of 1/1440 of the monthly charges for the facility or service for each period of 30 minutes. For service interruptions 4 hours or greater, the customer shall be credited as follows.

(i) For the initial 4 hour outage in a 30 day period, in lieu of the credit previously described, the customer will be credited as shown in the Credit Allowance Schedule below.

(ii) Additional service interruptions that are 4 hours or greater that occur in the same 30 day period will be calculated at the rate of 1/1440 per 30 minute interval.

The total credit allowance available to the customer regardless of the number or type of service interruptions within a 30 day period will not exceed 100% of the combined monthly rates per affected service.

An interruption period starts when an inoperative service is reported by the customer to the Telephone Company for repair and ends when the service is operative. The customer must make the circuit available for testing by the Telephone Company and provide access as needed. Suspension of the calculated interruption period will occur when access to the customer premises can not be gained or the customer does not release the circuit experiencing trouble.

Credit Allowance Schedule

<u>Interruption Period</u>		<u>Service</u>		<u>Applicable Credit</u>	
	4 Hours or More	Metallic	\$	5.00	
Telegraph	\$ 5.00				
		Program Audio	\$	10.00	
		Video	\$	10.00	
Direct Analog	\$ 10.00				
Base Rate	\$ 15.00				
DS1	\$ 120.00				
DS3	\$ 380.00				
Voice Grade Entrance Facilities	\$ 10.00				
LT1 Entrance Facilities	\$ 120.00				
LT3 Entrance Facilities	\$ 380.00				
Voice Grade Direct Transport	\$ 10.00				
LT1 Direct Transport	\$ 120.00				
		LT3 Direct Transport	\$	380.00	

* Credit allowances are not available for Optical Services associated with the DS3 Service Package, DS3 Service Channel and Entrance Facilities LT-3 subscribed to, on or after March 8, 2001.

(This page filed under Transmittal No. 1388)

ACCESS SERVICE

2. General Regulations (Cont'd)

2.4 Payment Arrangements and Credit Allowances (Cont'd)

2.4.4 Credit Allowance for Service Interruptions (Cont'd)

(B) When a Credit Allowance Applies (Cont'd)

(12)⁽¹⁾

(D)

(D)

(13) For Access services provided as Special Facilities Routing Arrangements as described in Section 11.1.1 following, the customer shall be credited 100 percent of the monthly rates for the Special Facilities Routing Arrangements and associated Local Distribution Channels, Entrance Facilities, Channel Mileage Terminations and Channel Mileage for each identified service when both the normal transmission path (normal service) and the designated diverse transmission path (diverse service) experience simultaneous service interruptions of 1 minute or more. An interruption period starts when the inoperative normal and diverse services are reported by the customer to the Telephone Company for testing/repair and ends when the services are operative. In order to qualify for this credit, the outages must be determined by the Telephone Company to be in its network.

The total credit allowance available to a customer regardless of the number of service interruptions in any month may not exceed 100 percent of the monthly rates of the service.

⁽¹⁾ Material in this Section has been de-tariffed as required by the Commission upon use of the forbearance relief pursuant to FCC Memorandum Opinion and Order No. 07-180, released October 12, 2007. Terms and Conditions associated with de-tariffed services are available at www.att.com/guidebook.

(This page filed under Transmittal No. 1666)

2. General Regulations (Cont'd)

2.4 Payment Arrangements and Credit Allowances (Cont'd)

2.4.4 Credit Allowance for Service Interruptions (Cont'd)

(B) When a Credit Allowance Applies (Cont'd)

- (14) For Switched Access Services, when service is interrupted due to the failure of a Telephone Company switch, a credit allowance will apply under the Switched Access Switch Assurance Warranty (SASAW) when the switch outage is of greater than thirty minutes duration and affects more than 30,000 Network Access Lines. The amount of the credit allowance is determined based on recent historical end office call data by: date, time of day, feature group, usage type, and ACNA. This information will be used to estimate the like time period called data history necessary to calculate the reimbursement amount. The estimated minutes of use by customer for the like time period will be rated using the current Telephone Company rates for carrier common line (CCL), local switching (LS2), information surcharge (IS) and the residual charge (RC). The credit will be applied to the customer's next bill.

(T)

The SASAW applies to all access customers that terminate switched traffic to end users served by a Telephone Company end office.

- (15) For Switched Access Service, through the 800 Service Guarantee Program, the Telephone Company will credit the customer's bill for 800 Service query charges when the 800 Service cannot perform the carrier identification function at the Telephone Company's Service Control Point (SCP). A credit will be given when the total time that the 800 Service cannot perform the carrier identification function at the SCP exceeds five (5) minutes per billing month. Specifically, the Telephone Company will credit the customer bill for all 800 service query charges for the day (defined as the 24 hour period; midnight to midnight) in which the five (5) minute threshold is exceeded. Only one (1) credit will be allowed per 800 Service customer per month. The credit will be applied to the customer's next monthly billing statement.

(T)

The 800 Service Guarantee Program applies to all 800 Service customers.

(This page filed under Transmittal No. 1388)

2. General Regulations (Cont'd)

2.4 Payment Arrangements and Credit Allowances (Cont'd)

2.4.4 Credit Allowance for Service Interruptions (Cont'd)

(B) When a Credit Allowance Applies (Cont'd)

- (16) For Special Access SNET Xpress Service, any verifiable service interruption will result in a credit of 100 percent of the monthly rates for the circuit or portion of the circuit involved.

(T)

An interruption period will start when an inoperative service is reported to the Telephone Company and end when the service is operative. In any month, as a result of service interruptions, the total credit per rate element of the interrupted service may not exceed 100 percent of the monthly charge for that particular rate element.

(This page filed under Transmittal No. 1388)

2. General Regulations (Cont'd)

2.4 Payment Arrangements and Credit Allowances (Cont'd)

2.4.4 Credit Allowance for Service Interruptions (Cont'd)

(C) When A Credit Allowance Does Not Apply

M

No credit allowance will be made for:

- (1) Interruptions caused by the negligence of the customer.
- (2) Interruptions of a service due to the failure of equipment or systems provided by the customer or others.
- (3) Interruptions of a service during any period in which the Telephone Company is not afforded access to the premises where the service is terminated.
- (4) Interruptions of a service when the customer has released that service to the Telephone Company for maintenance purposes, to make rearrangements, or for the implementation of an order for a change in the service during the time that was negotiated with the customer prior to the release of that service. Thereafter, a credit allowance as set forth in (B) preceding applies.
- (5) Interruptions of a service which continue because of the failure of the customer to authorize replacement of any element of special construction, as set forth in Interstate Special Construction Tariffs described in Section 1.5 preceding. The period for which no credit allowance is made begins on the seventh day after the customer receives the Telephone Company's written notification of the need for such replacement and ends on the day after receipt by the Telephone Company of the customer's written authorization for such replacement.
- (6) For service provided under a Shared Facility Credit/Shared Facility Channel Service arrangement, any affected customer not notifying the Telephone Company of a service outage will not receive a credit allowance.

M

Certain material on this page previously appears on 1st Revised Page 50.6.

(TR949)

(This page filed under Transmittal No. 949)

2. General Regulations (Cont'd)

2.4 Payment Arrangements and Credit Allowances (Cont'd)

2.4.4 Credit Allowance for Service Interruptions (Cont'd)

(C) When a Credit Allowance Does Not Apply (Cont'd)

- (6) Periods when the customer elects not to release the service for testing and/or repair and continues to use it on an impaired basis.
- (7) Periods of temporary discontinuance as set forth in 2.2.1(B) preceding.
- (8) Periods of interruption as set forth in 13.3.1 following.
- (9) An interruption or a group of interruptions, resulting from a common cause, for amounts less than one dollar, except for End User Common Line credits.
- (10) Credit Allowance for Service Interruptions will apply when service is interrupted due to labor difficulties, governmental orders, civil commotions, criminal actions taken against the Telephone Company, acts of God and other circumstances beyond the Telephone Company's reasonable control. No credit shall be allowed for an interruption period of less than 30 minutes. The customer will be credited for an interruption of 30 minutes or more at the rate of 1/1440 of the monthly charges for the facility or service for each period of 30 minutes or fraction thereof that the interruption continues after the initial 30 minute interruption. However, credits shown in the Credit Allowance Schedule found in 2.4.4 (B) (10) for outages greater than 4 hours will not apply. However, the Credit Allowance for Service Interruptions, as specified in 2.4.4 (B)(11) will not apply.

(N)
—
(N)

(D) Use of an Alternative Service Provided by the Telephone Company

Should the customer elect to use an alternative service provided by the Telephone Company during the period that a service is interrupted, the customer must pay the tariffed rates and charges for the alternative service used.

(E) Temporary Surrender of a Service

In certain instances, the customer may be requested by the Telephone Company to surrender a service for purposes other than maintenance, testing or activity relating to a service order. If the customer consents, a credit allowance will be granted. The credit allowance will be 1/440 of the monthly rate for each period of 30 minutes or fraction thereof that the service is surrendered. In no case will the credit allowance exceed the monthly rate for the service rendered in any one monthly billing period.

(This page filed under Transmittal No. 1388)

2. General Regulations (Cont'd)

2.4 Payment Arrangements and Credit Allowances (Cont'd)

2.4.5 Reestablishment of Service Following Fire, Flood or Other Occurrence

(A) Nonrecurring Charges Do Not Apply

Charges do not apply for the reestablishment of service following a fire, flood or other occurrence attributed to an Act of God provided that:

- (1) The service is of the same type as was provided prior to the fire, flood or other occurrence.
- (2) The service is for the same customer.
- (3) The service is at the same location on the same premises.
- (4) The reestablishment of service begins within 60 days after Telephone Company service is available. (The 60 day period may be extended a reasonable period if the renovation of the original location on the premises affected is not practical within the allotted time period).

(B) Nonrecurring Charges Apply

Nonrecurring Charges apply for establishing service at a different location on the same premises or at a different premises pending reestablishment of service at the original location.

(D)

2.4.6 Title or Ownership Rights

- (A) The payment of rates and charges by customers for the services offered under the provisions of this tariff does not assign, confer or transfer title or ownership rights to proposals or facilities developed or utilized, respectively, by the Telephone Company in the provision of such services.

(This page filed under Transmittal No. 1818)

2. General Regulations (Cont'd)

2.4 Payment Arrangements and Credit Allowances (Cont'd)

2.4.7 Ordering, Rating and Billing of Access Services Where More Than One Exchange Telephone Company is Involved

- (A) When an Access Service is ordered by a customer where one end of the Switched Transport, Directory Transport or Channel Mileage is in one Exchange Telephone Company operating territory and the other end is in another Exchange Telephone Company operating territory, or where the 900 NXX translation service and the end office are not provided by the same Exchange Telephone company (jointly provided services), the Exchange Telephone Company that accepts the order will be determined as set forth in (1) through (4) following. Each Exchange Telephone Company involved will receive a copy of the order and will arrange to provide its portion of the service. Ordering provisions for jointly provided services will conform to industry standards as established in the Multiple Exchange Carrier Ordering and Design Guidelines (MECOD).
- (1) For Switched Access Services ordered in lines or trunks and 900 Access Service, the customer will place the order with the Telephone Company in whose territory the first point of switching is located.
 - (2) For Special Access Service provided without the use of a hub, or Switched Access Services ordered in busy hour minutes of capacity, the Exchange Telephone Company in whose territory the customer's end user is located will accept the order for the Access Service from the customer.
 - (3) When a Special Access Service provided with the use of a Hub is ordered by a customer, the Exchange Telephone Company in whose territory the Hub is located will accept the order for the Access Service from the customer.
 - (4) For Directory Assistance Service, the customer will place the order with the Telephone Company in whose territory the Directory Assistance Location is located.

T

(TR736)

(This page filed under Transmittal No. 736)

ACCESS SERVICE

2. General Regulations (Cont'd)

2.4 Payment Arrangements and Credit Allowances (Cont'd)

2.4.7 Ordering, Rating and Billing of Access Services Where More Than One Exchange Telephone Company is Involved (Cont'd)

(B) The Telephone Companies will handle rating and billing of Access Services under this tariff where more than one Exchange Telephone Company is involved in the provision of Access Service as set forth in (1) through (4) following. The choice of billing method shall be made by the Telephone Companies based on the interconnection arrangements between the Exchange Telephone Companies involved. The company accepting the order will notify the customer of the billing method to be used and the Exchange Telephone Company(s) that will render the bill(s). The Exchange Telephone Company will provide such notice in writing at least 30 days prior to implementation of these billing methods and at least 30 days in advance of any billing method change. The option set forth in (1) following applies only to Feature Group A. Options 2 through 4 apply to Special Access Services, Directory Assistance, and all other Switched Access Services. Rating and billing will conform to industry standards as established in the Report of the Meet Point Billing Task Force, Ordering and Billing Forum, Exchange Carriers Standards Association, Inc. (ECSA Report) and the Multiple Exchange Carrier Access Billing Guidelines (MECAB).

When an Ameritech Operating Company is the billing company, billing for Feature Group A will be done using option 1, and billing for all other Switched Access Services, Directory Assistance, and Special Access Services will be done using options 2 through 4.

Regardless of the billing option used for interoffice services, Switched Transport Entrance Facilities and Special Access Local Distribution Channels may be billed by the Exchange Telephone Company that provides these facilities.

(1) Single Bill Arrangement for Feature Group A

For Feature Group A, the Exchange Telephone Company that accepts the order will determine the charges involved, arrange to provide the Access Service ordered, and bill the charges in accordance with its Access Service tariff.

(C)

(This page filed under Transmittal No. 1634)

2 General Regulations (Cont'd)

2.4 Payment Arrangements and Credit Allowances (Cont'd)

2.4.7 Ordering, Rating and Billing of Access Services Where More Than One Exchange Telephone Company Is Involved (Cont'd)

(B) (Cont'd)

(2) Single Bill/Single Tariff Billing Arrangement

For Special Access Services, Directory Assistance, and Switched Access Services other than Feature Group A, the Exchange Telephone Company that has been designated as the billing company will then determine the charges involved, arrange to provide the Access Service ordered and bill the charges in accordance with its Access Service tariff.

For Feature Group B, the billing company may be that of the company providing the access tandem or the end office, provided all Feature Group B Service provided to an end office is treated consistently. The choice of billing company will be made by the Telephone Company subject to the interconnection arrangements between the Exchange Telephone Companies involved, and the Telephone Company will notify the customer of which company will provide billing when service is ordered.

For Feature Group D provided in conjunction with Data Base Services, the billing company may be the company providing the Service Switching Point (SSP). (D)

(This page filed under Transmittal No. 1801)

ACCESS SERVICE

2. General Regulations (Cont'd)

2.4 Payment Arrangements and Credit Allowances (Cont'd)

2.4.7 Ordering, Rating and Billing of Access Services Where More Than One Exchange Telephone Company is Involved (Cont'd)

(B) (Cont'd)

(3) Single Bill/Multiple Tariff Billing Arrangements

When the billing company, as identified in (2) above, elects to provide a single bill which includes each Exchange Telephone Company's rates for the jointly provided service, the company that has been designated as the billing company will arrange to provide the service, bill and collect all charges. The bill will separately identify each company's rates and charges.

(D)
(D)

(4) Multiple Bill Arrangement

When an Access Service is jointly provided and the administration of a single bill arrangement cannot be agreed upon by the companies involved, each Exchange Telephone Company will provide its portion of the Access Service based on the regulations, rates and charges contained in its Access Service tariff, subject to the following rules as appropriate.

(D)
(D)
(D)

(a) The charges billed by each company for mileage sensitive rate elements, e.g., Switched Transport, Special Access Service Channel Mileage, or Directory Assistance Transport, are determined as follows:

(i) The total mileage for the service is computed using the V&H Coordinate Method set forth in National Exchange Carrier Association Tariff F.C.C. No. 4 (NECA No. 4).

For Switched Transport routed through an Access Tandem, at the customer's option, mileage may be measured on an airline basis between the End Office and the Serving Wire Center. This option expires July 1, 1998. After that date, mileage will be measured between the End Office and the Access Tandem and between the Access Tandem and the Serving Wire Center.

(This page filed under Transmittal No. 1634)

ACCESS SERVICE**2. General Regulations (Cont'd)****2.4 Payment Arrangements and Credit Allowances (Cont'd)****2.4.7 Ordering, Rating and Billing of Access Services Where More Than One Exchange Telephone Company is Involved (Cont'd)****(B) (Cont'd)****(4) Multiple Bill Arrangement (Cont'd)****(a) (Cont'd)**

- (ii)** The billing percentage (BP), which represents the portion of the service provided by each Exchange Telephone Company, is determined as set forth in NECA No. 4. T
 - (iii)** Each company's rates and charges are then multiplied by the appropriate quantity(ies) and the billing percent to obtain the charges for that company.
- (b)** The application of nondistance sensitive rate elements varies according to the rate structure and the location of the facilities involved:
- (i)** When rates and charges are listed on a per point of termination basis, each company's rates will be billed for the termination(s) within its operating territory.
 - (ii)** When rates and charges are listed on a per unit basis, e.g., central office bridging or multiplexing, each company's rates and charges will apply for units located in its operating territory.

(This page filed under Transmittal No. 686)

ACCESS SERVICE**2. General Regulations (Cont'd)****2.4 Payment Arrangements and Credit Allowances (Cont'd)****2.4.7 Ordering, Rating and Billing of Access Services Where More Than One Exchange Telephone Company is Involved (Cont'd)****(B) (Cont'd)****(4) Multiple Bill Arrangement (Cont'd)****(b) (Cont'd)**

(iii) When rates and charges are developed on an individual case basis, such rates will be developed for the portion of the service provided by each company.

(iv) When rates and charges are listed on a per service basis, each company's rates and charges will be multiplied by the billing percent referenced above to determine the charges to be billed.

(v) For Switched Access and Directory Assistance, the Tandem-Switched Termination, Common Multiplexing and Tandem-Switched Directory Assistance Termination rates for each company terminating an end of the service will be multiplied by 50 percent. For intermediate companies not terminating an end of the service, the transport termination charges will not apply.

(vi) The Tandem Switching rate will be charged by the exchange telephone company in which tandem switching occurs.

For Direct Switched Transport facilities between the tandem and the serving wire center, elements that are billed on a flat monthly basis will be billed in accordance with (a) and (b)(i), preceding.

(vii) For Special Access and direct-routed Switched Transport for intermediate companies not terminating an end of the service, the Channel Mileage Termination rate will not apply.

(viii) For Feature D provided in conjunction with Data Base Services, charges associated with the data base will be billed by the company providing the SSP. (D)

(ix) For Ameritech Frame Relay, charges associated with User-to-Network Interface (UNI), Network-to-Network Interface (NNI), Hubbed UNI and Hubbed NNI connection will be billed by the Company providing the frame relay service.

(This page filed under Transmittal No. 1801)

ACCESS SERVICE**2. General Regulations (Cont'd)****2.4 Payment Arrangements and Credit Allowances (Cont'd)****2.4.7 Ordering, Rating and Billing of Access Services Where More Than One Exchange Telephone Company is Involved (Cont'd)****(B) (Cont'd)****(4) Multiple Bill Arrangement (Cont'd)**

- (c)** The application of nonrecurring charges is as follows:
- (i)** The Administrative Charge for both Switched Access and Special Access will apply in full per Access Service Request for each order or copy of an order received.
 - (ii)** The Design and Central Office Connection Charge for both Switched Access Services, Switched Transport Service and Special Access will be multiplied by the billing percent, and applies per line or trunk for Switched Access Services and per circuit for Switched Transport Service and Special Access Services. These charges will only apply when actual installation activity is required and identifiable for a specified customer order. C
C
 - (iii)** The Customer Connection Charge for Switched Access Services will be multiplied by the billing percent, and applies per line or trunk. These charges will only apply when actual installation activity is required and identifiable for a specified customer order. T
 - (iv)** The Customer Connection Charge for Switched Transport Entrance Facilities applies per point of termination at the customer premises. N
N
 - (v)** The Customer Connection Charge for Special Access applies per termination, and each company's rates will be billed in full for the termination(s) within its operating territory. T
 - (vi)** The Design and Central Office Connection Charge and the Customer Connection Charge for both Switched and Special Access will not apply when the Telephone Company has status as an intermediate carrier in a jointly provided service. T

(This page filed under Transmittal No. 736)

ACCESS SERVICE

2. General Regulations (Cont'd)

2.4 Payment Arrangements and Credit Allowances (Cont'd)

2.4.7 Ordering, Rating and Billing of Access Services Where More Than One Exchange Telephone Company is Involved (Cont'd)

(C) Example - Switched Access

Layout

- (a) Feature Group D Switched Access is ordered to End Office A.
- (b) End Office A is in operating territory of Exchange Telephone Company A.
- (c) Premises of ordering Customer is in operating territory of Exchange Telephone Company B.

(1) Direct Routed Transport

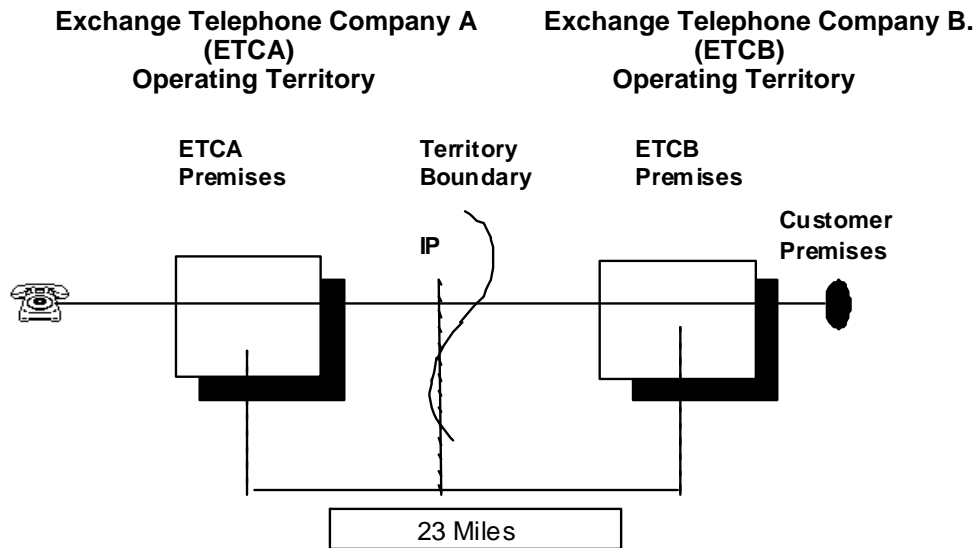

IP = Interconnection Point

(This page filed under Transmittal No. 1135)

ACCESS SERVICE

2. General Regulations (Cont'd)

2.4 Payment Arrangements and Credit Allowances (Cont'd)

2.4.7 Ordering, Rating and Billing of Access Services Where More Than One Exchange Telephone Company is Involved (Cont'd)

(C) Example - Switched Access (Cont'd)

(2) Tandem Routed Transport Measured End Office to Serving Wire Center*

TANDEM-SWITCHED SERVICES

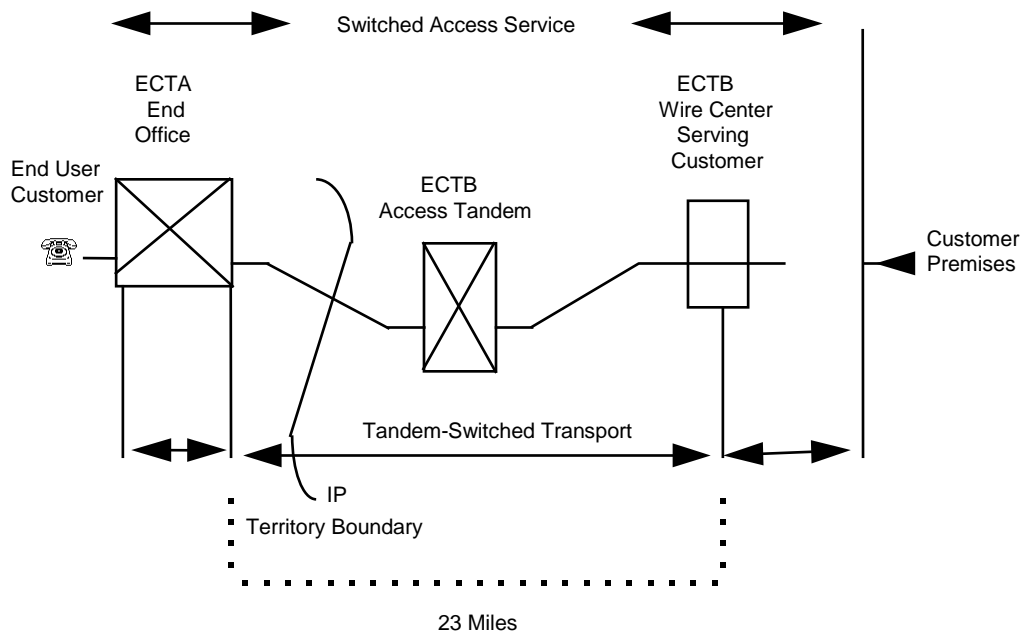

- ETCA - Exchange Telephone Company A
- ETCB - Exchange Telephone Company B
- IP - Interconnection Point

* This option expires July 1, 1998.

(This page filed under Transmittal No. 1135)

N
N

ACCESS SERVICE

2. General Regulations (Cont'd)

2.4 Payment Arrangements and Credit Allowances (Cont'd)

2.4.7 Ordering, Rating and Billing of Access Services Where More Than One Exchange Telephone Company is Involved (Cont'd)

(C) Example - Switched Access (Cont'd)

(3) Tandem Routed Transport with Direct Transport to Tandem

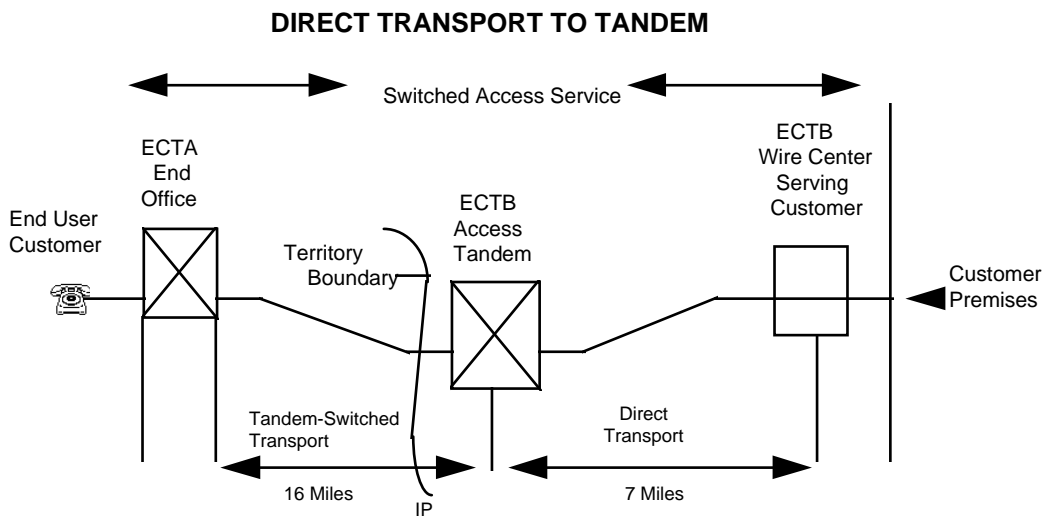

ETCA - Exchange Telephone Company A
 ETCA - Exchange Telephone Company B
 IP - Interconnection Point

N
N

(This page filed under Transmittal No. 1135)

ACCESS SERVICE

2. General Regulations (Cont'd)

2.4 Payment Arrangements and Credit Allowances (Cont'd)

2.4.7 Ordering, Rating and Billing of Access Services Where More Than One Exchange Telephone Company is Involved (Cont'd)

(C) Example 1 - Switched Access (Cont'd)

The following example reflects the rate calculations for an end office company (ETCA). Rates for ETCB company would appear in the appropriate access tariff.

Airline miles (ALM) ETCA premises to ETCB premises = 22.1, rounded = 23.

Billing Percentage (BP)

ETCA = 56%

ETCB = 44%

ETCA: Direct Transport Channel Mileage Rate \$23.00

(5)BP Method

Formula:

LT-1 Direct Transport Channel Mileage Rates x miles
 x Billing Percentage (BP) = Total ETCA mileage charge per month.

Calculation

ETCA

Rate		Miles		BP	
\$23.00	X	23	X	.56	= \$296.24

(This page filed under Transmittal No. 1160)

ACCESS SERVICE

2. General Regulations (Cont'd)

2.4 Payment Arrangements and Credit Allowances (Cont'd)

2.4.7 Ordering, Rating and Billing of Access Services Where More Than One Exchange Telephone Company is Involved (Cont'd)

(C) (Cont'd)

Example 3 - Switched Access

The following examples reflect the rate calculations for an end office company (ETCA). Rates for ETCB company would apply for Tandem Switched Direct Transport and Entrance Facility, and appear in the appropriate access tariff.

C
 C

(1) Assume:

Airline miles (ALM) ETCA premises to ETCB premises to interconnection point = 16.

Billing Percentage (BP)
 ETCA = 56%
 ETCB = 44%

Access Minutes (AM) = 9000

Tandem Switched Facility Rates;
 ETCA: Tandem-Switched Service Rate (TSFR) = 0.000047

(2) BP Method

Formula:

Access Minutes (AM) x Tandem-Switched Facility Rate (TSFR) x miles x Billing Percentage (BP) = Total ETCA mileage charge per month.

Calculation

ETCA					
	AM	TSFR		BP	
	9000	X .000047	X 16	x .56	= 3.7900

(This page filed under Transmittal No. 1227)

ACCESS SERVICE**2. General Regulations (Cont'd)****2.4 Payment Arrangements and Credit Allowances (Cont'd)****2.4.8 Ordering, Rating and Billing of Access Services Provided in Conjunction With a Cellular Carrier or a Radio Common Carrier**

- (A) When Switched Access Service is ordered by a customer in conjunction with public mobile service, where the Local Transport is provided by the Telephone Company and the end user connection is provided by a Cellular Carrier or a Radio Common Carrier (RCC), the Telephone Company will provide its portion of the Switched Access Service based on the regulations, rates and charges contained in its Access Service tariff, subject to the following rules.
- (1) For Switched Access Service which is directly connected to the Cellular Carrier or the RCC at an access tandem, Direct Transport rates apply between the Access Tandem and the Serving Wire Center.
 - (2) The mileage to be used to determine the Direct Transport Channel Mileage Charge is calculated as set forth in paragraph 6.8.13(l).
 - (3) For Switched Access Service which is directly connected to the Cellular Carrier or the RCC at either an end office or an access tandem, the Tandem Switching Rate and the Residual Charge, as set forth in Section 6.9.1, apply.
 - (4) For Feature Groups B and D Switched Access service directly connected to the Cellular Carrier or the RCC at an access tandem, where the Telephone Company does not provide end office local switching functions, Local Switching and Common Trunk Port rates set forth in paragraph 6.9.2 do not apply. (D)
 - (5) For all Switched Access services provided in conjunction with a Cellular Carrier or RCC where Telephone Company common line facilities are not used, Carrier Common Line Charges set forth in paragraph 3.9 do not apply.

(This page filed under Transmittal No. 1801)

ACCESS SERVICE

2. General Regulations (Cont'd)

2.4 Payment Arrangements and Credit Allowances (Cont'd)

2.4.8 Ordering, Rating and Billing of Access Services Provided in Conjunction With a Cellular Carrier or a Radio Common Carrier (Cont'd)

(A) (Cont'd)

- (5)** The following diagram depicts Switched Access Service which is directly connected to the Cellular Carrier or the RCC at an access tandem.

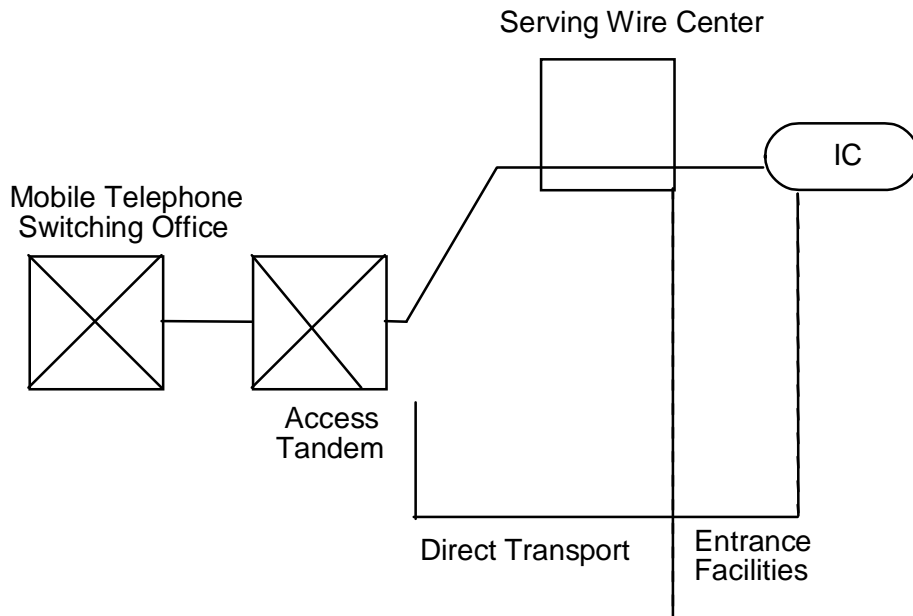

Cellular Mobile Carrier Interconnects with Local Exchange Carrier at the Access Tandem

Interoffice Switched Transport is provided as Direct Transport, per 6.1.3(A)(1). The Tandem Switching charge applies.

T

T

C

(This page filed under Transmittal No. 1227)

2. General Regulations (Cont'd)

2.4 Payment Arrangements and Credit Allowances (Cont'd)

2.4.8 Ordering, Rating and Billing of Access Services Provided in Conjunction With a Cellular Carrier or a Radio Common Carrier (Cont'd)

(A) (Cont'd)

(6) The following diagram depicts Switched Access Service which is directly connected to the Cellular Carrier or the RCC at an end office.

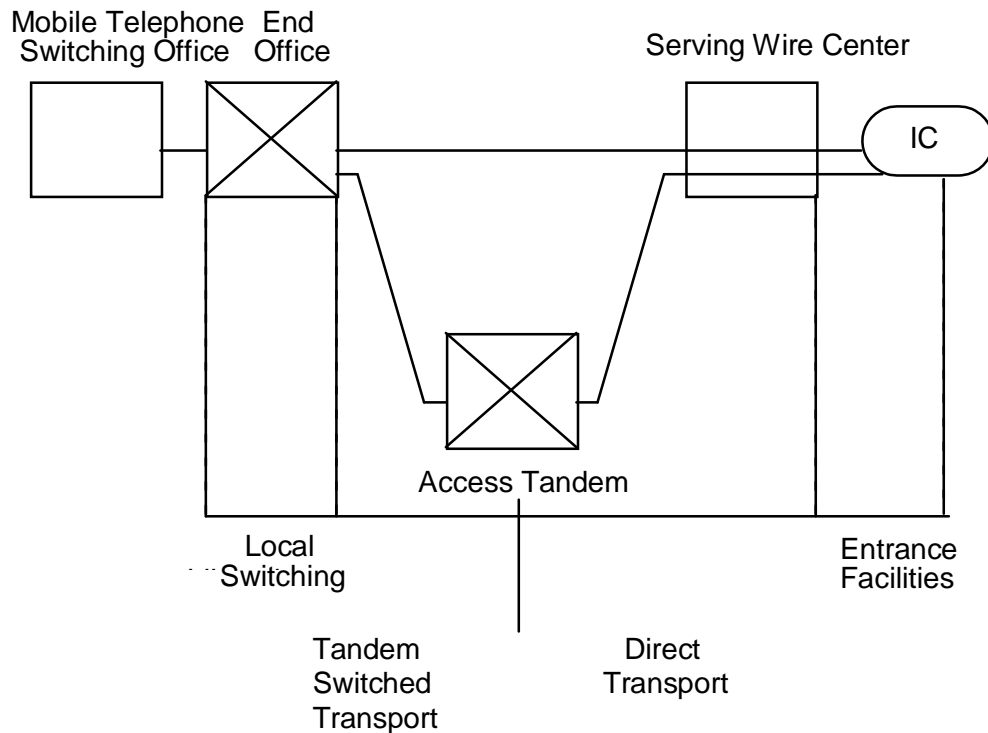

C

C

Cellular Mobile Carrier Interconnects with Local Exchange Carrier at the End Office

Interoffice Switched Transport is provided as Tandem-Switched Transport and Direct Transport, per 6.1.3(A)(1). The Tandem Switching charge applies.

C

C

(This page filed under Transmittal No. 1227)

ACCESS SERVICE**2. General Regulations (Cont'd)****2.4 Payment Arrangements and Credit Allowances (Cont'd)****2.4.9 Ordering, Rating and Billing of Access Services Provided in Conjunction With Telecommunications Relay Services (TRS)**

- | | | |
|------------|---|-------------|
| (A) | When Switched Access Service is provided to a customer in conjunction with TRS Access Service, where the Switched Transport is provided between the TRS end user's carrier of choice and the TRS Access Tandem, the Telephone Company will provide the Switched Access Service based on the regulations, rates and charges contained in Section 6 of this tariff, subject to the following rules: | C |
| (1) | Tandem-Switched Transport or Direct Transport rates will apply for the Switched Access Service provided in conjunction with TRS Access as set forth in Sections 6.9.1 and 6.9.6. | C
T |
| (2) | The mileage to be used to determine the Tandem-Switched Facility Charges or Direct Transport Channel Mileage is calculated as set forth in Section 6.8.12(J). | C

C |
| (3) | The Residual Charge will apply, as set forth in Section 6.8.1, for FGD Switched Access Service provided in conjunction with TRS Access. | N
N |
| (4) | Local Switching rates as set forth in Section 6.9.2(A) do not apply for FGD Switched Access Service provided in conjunction with TRS Access. | T |
| (5) | Information Surcharge rates as set forth in Section 6.9.8 do not apply for FGD Switched Access Service provided in conjunction with TRS Access. | T |
| (6) | Carrier Common Line Charges as set forth in Section 3.9 do not apply for FGD Switched Access Service provided in conjunction with TRS Access. | T |

(This page filed under Transmittal No. 782)

2. General Regulations (Cont'd)

2.4 Payment Arrangements and Credit Allowances (Cont'd)

2.4.9 Ordering, Rating and Billing of Access Services Provided in Conjunction With Telecommunications Relay Services (TRS)

(C) TRS Access Service is depicted in the following diagram:

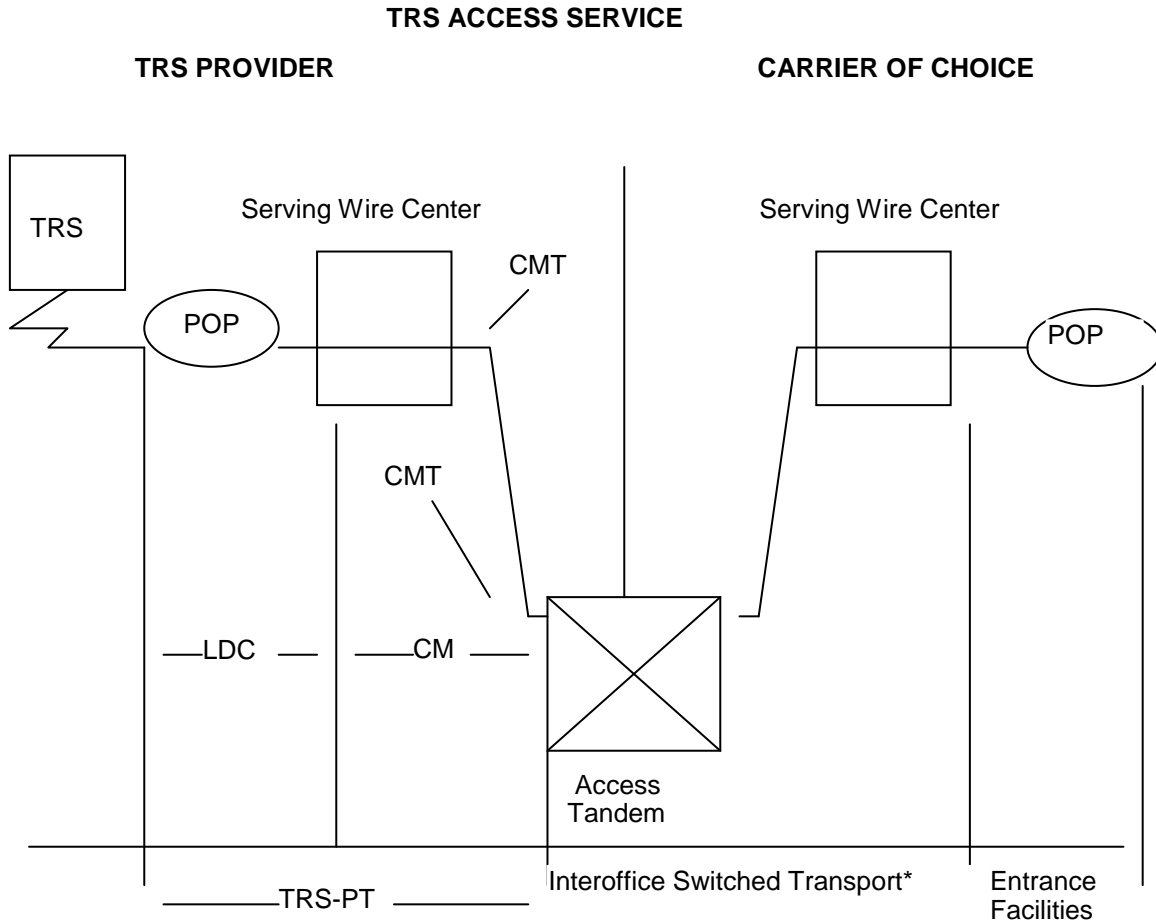

- | | | |
|--------|---|-----------------------------------|
| TRS | = | Telecommunications Relay Services |
| TRS-PT | = | TRS Provider Transport |
| CM | = | Channel Mileage |
| CMT | = | Channel Mileage Termination |
| LDC | = | Local Distribution Channel |
| SWC | = | Serving Wire Center |
| POP | = | Point of Presence |

* Interoffice Switched Transport may be provided as Tandem-Switched Transport or Direct Transport, per 6.1.3(A)(1). The Tandem Switching charge applies.

(This page filed under Transmittal No. 782)

C
C
N
N

ACCESS SERVICE

2. General Regulations (Cont'd)

2.4 Payment Arrangements and Credit Allowances (Cont'd)

Dx

Dx

(This page filed under Transmittal No. 764)

ACCESS SERVICE

2. General Regulations (Cont'd)

2.5 Connections

(D)

Equipment and Systems (i.e., terminal equipment, multiline terminating systems and communications systems) may be connected with Switched and Special Access Service furnished by the Telephone Company where such connection is made in accordance with the provisions specified in Technical Reference Publication AS No. 1 and in 2.1 preceding.

(This page filed under Transmittal No. 27)

2. General Regulations (Cont'd)

2.6 Definitions

Certain terms used herein are defined as follows:

Access Code - a uniform seven digit code assigned by the Telephone Company to an individual customer. The seven digit code has the form 101XXXX and 950-XXXX.

Access Customer Name Abbreviation (ACNA) – denotes a three alpha character code that identifies the customer to which the Access Service bill is rendered.

Access Customer Terminal Location (ACTL) - denotes the eleven (11) character Common Language Location Identifier (CCLI) code identifying the customer's Point of Presence (POP/InterLATA facility terminal location).

Access Minutes - that usage of exchange facilities in interstate or foreign service which is used to calculate chargeable usage. On the originating end of an interstate or foreign call, usage is measured from the time the originating end user's call is delivered by the Telephone Company to and acknowledged as received by the customer's facilities connected with the originating exchange. On the terminating end of an interstate or foreign call, usage is measured from the time the call is received by the end user in the terminating exchange. Timing of usage at both originating and terminating ends of an interstate or foreign call shall terminate when the calling or called party disconnects, whichever event is recognized first in the originating and terminating exchanges, as applicable.

Access Tandem - a Telephone Company switching system that provides a concentration and distribution function for originating or terminating traffic between end offices and a customer's premises.

Access Transport - an SS7 parameter which is used to transport ISDN user information transparently (i.e., the Telephone Company switch does not use the Access Transport Parameter data) across the network.

Alternate Access Tandem - an access tandem owned by a party other than the Telephone Company.

Alternate Card Access service - an originating switched access service that enables customers to receive originating InterLATA or international sent-paid traffic when the customers' end users place calls from designated Telephone Company pay phones using the Ameritech debit card.

(x)

Ameritech debit card - a card available to end user customers in varying dollar denomination values that can be used in conjunction with Alternate Card Access service to place prepaid interLATA or international sent-paid calls from designated Telephone Company pay phones without the use of coins.

(x)

Ameritech PrePaid Calling Card (APCC) - a card available to end users in varying dollar denominations. It can be used to place prepaid sent-paid calls from any telephone without the use of coins.

- (x) Issued under authority of Special Permission No. 11-003 of the FCC in order to withdraw material filed under Transmittal No. 1730 without its becoming effective and to restore currently effective material.

(This page filed under Transmittal No. 1734)

General Regulations (Cont'd)

2.6 Definitions (Cont'd)

Answer/Disconnect Supervision - the transmission of the switch trunk equipment supervisory signal (off-hook or on-hook) to the customer's point of termination as an indication that the called party has answered or disconnected.

Arrangement - A Feature Group A line, multiline hunt group or a group of trunks. When a feature is offered by arrangement, the rate is applied once per multiline hunt group or group of trunks.

NRS Termination - the circuit termination point on the NRS system. (T)

NRS System Location - an electronic switching node utilized by the Network Reconfiguration Service (RS) that enables circuits to be cross-connected. (T)

Attendant Access - a method of access to the NRS which provides customers the ability to contact a Telephone Company attendant who performs a reconfiguration of service management activity at the customers request. (T)

Attenuation Distortion - the difference in loss at specified frequencies relative to the loss at 1004 Hz, unless otherwise specified.

Automatic Number Identification (ANI) - a multi-frequency signaling Common Switching Optional Feature# that provides the automatic transmission of a seven or ten digit number and information digits* to the customer's premises for call originating in the LATA, to identify the calling station. Additional information indicator digits are available with the chargeable optional feature Flex ANI.

Balance (100 Type) Test Line - an arrangement in an end office which provides for balance and noise testing.

Basic Initial Address Message Delivery - a Common Switching Optional feature where an SS7 message sent in the forward direction to initiate trunk set up with the busying of an outgoing trunk that carries the information about that trunk along with other information relating to the routing and handling of the call to the next switch.

The SS7 protocol ANI equivalent is the Charge Number. The Charge Number is contained in the Basic Initial Address Message Delivery Common Switching Optional feature.

* The SS7 protocol information digits equivalent is the Originating Line Information

(This page filed under Transmittal No. 1357)

2. General Regulations (Cont'd)

2.6 Definitions (Cont'd)

Basic Service Arrangement (BSA) - A BSA encompasses both the hierarchical nature of network capabilities and the technical requirements for the delivery of unbundled network features and functions to enhanced service providers. It constitutes the minimum necessary arrangement for the delivery of these unbundled features and functions, and also provides a logical framework for the offering of ONA services.

There are four categories of BSAs; Circuit Switched, Dedicated (Special), Packet, and Dedicated Network Access Link (DNAL). These categories are divided into types. For example, the Packet BSA has two types; X.25 protocol and X.75 protocol. ⁽¹⁾The BSA types are further delineated into BSA alternatives. These alternatives uniquely distinguish the operation of the BSA functionalities. These alternatives must be specified at the time the BSA is ordered. An example of a BSA alternative is Feature Groups B and D on the circuit switched-trunk type BSA. (D)

(1) As of October 6, 2004, Packet Switched Network Service utilizing the X.75 protocol is obsolete and limited to existing installations, at existing locations, for existing customers.

(This page filed under Transmittal No. 1801)

2. General Regulations (Cont'd)

2.6 Definitions (Cont'd)

Basic Service Arrangement (BSA) (Cont'd) - The BSA is comprised of three elements, the Access Link, Transport and Features and Functions. The access link consists of facilities used to connect a customer designated premises to the serving wire center of that premises. This element contains the attributes inherent in the connection of a customer's designated premises to the point of network interconnection.

It will have alternative characteristics which can be selected by the customer, but one of which is necessary for communications transfer (e.g., 2-wire or 4-wire facilities). The features and functions element consists of fundamental capabilities resident in a customer serving wire center or a distant central office. It includes the routing and processing capabilities associated with the provision of end-to-end communications.

The transport element is the connection between central offices, such as serving wire center to another central office, where access to features and functions or end users is required. When the customer and end user are served from the same serving office, the transport element consists of an intraoffice connection.

Basic Service Element (BSE) - A BSE is an optional and unbundled network feature associated with a BSA. These features are specifically determined and developed based on the needs of enhanced service providers for use in provision of enhanced services, as defined in Amendment of Part 69 of the Commission's Rules, although they may be used by any interstate customer.

Billed Number Group - the NPA-NXX and/or RAO-0/1XX administered by the data owner.

Billed Number Screening (BNS) - data stored in the Telephone Company's Line Information Data Base stating whether the billed line automatically rejects, accepts or requires verification of calls billed as collect or third number.⁽¹⁾ Billed Number Screening also identifies Local Exchange Company public and nonworking telephone numbers and indicates whether a central office code is active or vacant. (N)

Bit - the smallest unit of information in the binary system of notation.

Broadcast Traffic – Ethernet frames that are forwarded to all stations on a virtual local area network using the broadcast address.

Business Day - the times of day that a company is open for business. This is 8:00 A.M. to 5:00 P.M., Monday through Friday.

Busy Hour Minutes of Capacity (BHMC) - the customer specified maximum amount of Switched Access Service and/or Directory Assistance Service access minutes the customer expects to be handled in an end office switch during any hour in an 8:00 A.M. to 11:00 P.M. period for the Feature Group and/or Directory Assistance Service ordered. This customer furnished BHMC quantity is the input data the Telephone Company uses to determine the number of transmission paths for the Feature Group and/or Directory Assistance Service ordered.

⁽¹⁾ Effective September 13, 2016, collect calls and calls billed to a third number have been discontinued by the Telephone Company. (N)
(N)

(This page filed under Transmittal No. 1850)

2. General Regulations (Cont'd)

2.6 Definitions (Cont'd)

C Band – 1525-1565 nanometers (unit of spatial measurement that is one billionth of a meter).

Call - a customer attempt for which the complete address code (e.g., 0, 911, or 10 digits) is provided to the serving dial tone office.

Call Aggregator - any customer that as part of their ordinary operations, makes telephones available to the public or to transient users of its premises, for interstate telephone calls that use a provider of operator services.

Call-out – A customer required dispatch outside of normal business hours when a technician is not available for dispatch.

Calling Party Number - an SS7 parameter identifying the directory number of the calling station.

Call Setup Packet - The first packet in each session containing the call request and call answer information. Call setup may consist of negotiated flow control parameters, the NUI code, termination network address, reverse billing indicator and up to 12 data octets.

(N)
(N)

(This page filed under Transmittal No. 1527)

2. General Regulations (Cont'd)

2.6 Definitions (Cont'd)

Carrier or Common Carrier - See Interexchange Carrier.

Carrier Identification Code - a numeric code currently used to identify customers who purchase FGB and/or FGD Access Services. These codes are primarily used for routing from the Telephone Company's network to the access purchaser and for billing between the Telephone Company and the access purchaser.

Carrier Selection Indicator - an SS7 parameter which identifies whether the originating line was presubscribed or not, and if the line was presubscribed, whether the end user dialed 101XXXX, did not dial 101XXXX, or if no indication of dialing is available.

Cascading Service User – Customer who has their service on a channel or port of a multiplexed DS1, DS3, or SONET service belonging to a Third Party Host through a Cascading Shared Network Arrangement.

Cascading Shared Network Arrangement – a service offering whereby a Cascading Service User may connect subtending services to a Third-Party Host's multiplexed DS1, DS3 or SONET service which is on a Shared Network Arrangement with a Host Subscriber, and the Telephone Company will undertake to maintain separate customer records and billing.

CCS - a hundred call seconds, which is a standard unit of traffic load that is equal to 100 seconds of usage or capacity of a group of servers (e.g., trunks).

Cell Site - a transmitter/receiver location, operated by a Commercial Mobile Radio Service (CMRS) provider, through which radio links are established between CMRS provider's cellular telephone network and wireless mobile units.

Central Office - a local Telephone Company switching system where Telephone Exchange Service customer station loops are terminated for purposes of interconnection to each other and to trunks.

Central Office Prefix - the first three digits (NXX) of the seven digit telephone number assigned to a customer's or customer's end user's Telephone Exchange Service.

Centralized Automatic Reporting on Trunks Testing - a type of testing which includes the capacity for measuring operational and transmission parameters.

Channel(s) - an electrical or photonic, in the case of fiber optic-based transmission systems, communications path between two or more points of termination.

Channel Service Unit - equipment which performs one or more of the following functions: termination of a digital facility, regeneration of digital signals, detection and/or correction of signal format errors and remote loop back.

Channelize - the process of multiplexing-demultiplexing wider bandwidth or higher speed channels into narrower bandwidth or lower speed channels.

Charge Number - see Automatic Number Identification.

C-Message Noise - the frequency weighted average noise within an idle voice channel. The frequency weighting, called C-message, is used to simulate the frequency characteristic of the 500-type telephone set and the hearing of the average subscriber.

(N)
 |
 (N)

(This page filed under Transmittal No. 1551)

2. General Regulations (Cont'd)

2.6 Definitions (Cont'd)

C-Notched Noise - the C-message frequency weighted noise on a voice channel with a holding tone, which is removed at the measuring end through a notch (very narrow band) filter.

Code, 0ZZ - codes that are used to route certain types of traffic to specific trunk groups such as, specific IC trunk groups, TOPS Trunk Groups, etc.

(Nx)

(Nx)

(Mx)

(Mx)

Certain material appearing on this page previously appeared on 12th Revised Page 61.

(x) Issued under authority of Special Permission No. 03-101 of the FCC.

(This page filed under Transmittal No. 1370)

2. General Regulations (Cont'd)

2.6 Definitions (Cont'd)

Commingling⁽¹⁾ - Commingling means the connecting, attaching or otherwise linking of an unbundled network element, or a combination of unbundled network elements, to one or more facilities or services that a requesting telecommunications carrier has obtained at wholesale from the Telephone Company, or the combining of an unbundled network element, or a combination of unbundled network elements with one or more such facilities or services. Commingling means the act of commingling.

Committed Information Rate (CIR)- A statistically guaranteed level of transmission or guaranteed bandwidth that the Ethernet network will provide to the Basic Connection when information (or data) needs to be transmitted.

Common Channel Signaling Network - a digital data network carrying signaling, routing, and control information which interfaces with the voice/data network.

Common Line - a line, trunk, pay telephone line or other facility provided under the general and/or local exchange service tariffs of the Telephone Company, terminated on a central office switch. A common line-residence is a line or trunk provided under the residence regulations of the general and/or local exchange service tariffs. A common line-business is a line provided under the business regulations of the general and/or local exchange service tariffs.

Communications System - channels and other facilities which are capable of communications between terminal equipment provided by other than the Telephone Company.

Competitive County - The term "Competitive County" denotes the geographic unit of a county or county-equivalent that either is competitive pursuant to the F.C.C.'s competitive market test or was granted Phase II, Level 2 pricing flexibility prior to June 1, 2017. (N)
(N)
(N)

Connecting Facility Assignment - a facility identification of the channel of a high capacity service on which a slower speed service rides.

Customer(s) - any individual, partnership, association, joint-stock company, trust, corporation, or governmental entity or any other entity which subscribes to the services offered under this tariff, including both Interexchange Carriers (ICs) and End Users.

Data Terminating Equipment (DTE) - in PSN service, devices (such as terminals, clusters of terminals or a host computer) on the customer's premises, which transmit or receive asynchronous, synchronous, character or bit-oriented data messages.

⁽¹⁾ In the event the Commission or a court, pursuant to any regulatory or judicial review of the Commission's *Review of the Section 251 Unbundling Obligations of Incumbent Local Exchange Carriers*, Report and Order and Order on Remand and Further Notice of Proposed Rulemaking, CC Docket No. 01-338, FCC 03-36, para. 581 (released Aug. 21, 2003) (*Triennial Review Order*), vacates, stays, remands, reconsiders, or rejects the portion of the Triennial Review Order requiring ILECs to permit commingling, the terms and conditions of this tariff authorizing commingling, which are identified with a footnote, shall cease to be effective as of the effective date of the Commission order or the issuance of the court's mandate. In that event, the Telephone Company will provide customers that have commingled UNE(s) and/or UNE Combination(s) with wholesale services obtained under this Tariff written notice that, within 30 days, customers must either convert such UNE(s) or UNE Combination(s) to a comparable service, or disconnect such UNE(s) and/or UNE Combination(s) from those wholesale services. Failure to provide the Telephone Company instructions to convert or disconnect such UNE(s) and/or UNE Combination(s) within 30 days, as described above, shall be deemed authorization to convert the UNE(s) and/or UNE Combination(s) to comparable access services at month-to-month rates.

(This page filed under Transmittal No. 1864)

ACCESS SERVICE

2. General Regulations (Cont'd)

2.6 Definitions (Cont'd)

Data Transmission (107 Type) Test Line - an arrangement which provides for a connection to a signal source which provides test signals for one-way testing of data and voice transmission parameters.

Decibel - a unit used to express relative difference in power, usually between acoustic or electric signals, equal to ten (10) times the common logarithm of the ratio of two signal powers.

Decibel Reference Noise C-Message Weighting - noise power measurements with C-Message Weighting in decibels relative to a reference 1000 Hz tone of 90 dB below 1 milliwatt.

Decibel Reference Noise C-Message Referenced to 0 - noise power in Decibel Reference Noise C-Message Weighting referred to or measured at a zero transmission level point.

(1)

(D)
(D)

(1)

(D)
(D)

Detail Billing - the listing of each message and/or rate element for which charges to a customer are due on a bill prepared by the Telephone Company.

Direct Inward Dialing - a trunk side termination, at the first point of switching, that permits the Central Office Switch to deliver all or part of the called number to the customer premises at the time the call is established.

Direct-Trunked Transport - Switched Transport provided between the customer's serving wire center and a Telephone Company end office, hub or tandem or between a hub or tandem and an end office on circuits dedicated to the use of a single customer without switching at an access tandem.

Direct-Trunked Transport Facility - A Switched Access transport facility used for Direct -Trunked Transport.

⁽¹⁾ Material in this Section has been de-tariffed as required by the Commission upon use of the forbearance relief pursuant to FCC Memorandum Opinion and Order No. 07-180, released October 12, 2007. Terms and Conditions associated with de-tariffed services are available at www.att.com/guidebook.

(This page filed under Transmittal No. 1666)

2. General Regulations (Cont'd)

2.6 Definitions (Cont'd)

Directory Assistance (Interstate) - the provision of telephone numbers by a Telephone Company operator.

Directory Assistance Location (Interstate) - a Telephone Company office where Telephone Company equipment first receives the Directory Assistance call from a customer's end user and selects the first available operator position to respond to the Directory Assistance call.

Directory Number (DN) - denotes a unique NPA-NXX-XXXX assigned to a subscriber of a Local Service Provider.

(M)

(M)

Material appearing on this page previously appeared on 11th Revised Page 61.1

(This page filed under Transmittal No. 1359)

ACCESS SERVICE

2. General Regulations (Cont'd)

2.6 Definitions (Cont'd)

Donor Switch - denotes the original switch source of an NXX that has been designated as portable and from which a subscriber has moved their service, while retaining their Directory Number, to a different service provider's switch. (N)
(N)

Dual Tone Multifrequency Address Signaling - a type of signaling that is an optional feature of Switched Access Feature Group A. It may be utilized when Feature Group A is being used in the terminating direction (from the point of termination with the customer to the local exchange end office). An office arranged for Dual Tone Multifrequency Signaling would expect to receive address signals from the customer in the form of Dual Tone Multifrequency signals. (M)
(M)

Echo Control - the control of reflected signals in a telephone transmission path.

Echo Path Loss - the measure of reflected signal at a four-wire point of interface without regard to the send and receive Transmission Level Point.

Echo Return Loss - a frequency weighted measure of return loss over the middle of the voiceband (approximately 500 to 2500 Hz), where talker echo is most annoying.

Effective Four-Wire - a condition which permits the simultaneous independent transmission of information in both directions over a channel. The method of implementing effective four-wire transmission is at the discretion of the Telephone Company (physical, time domain, frequency-domain separation or echo cancellation techniques). Effective four-wire channels may be terminated with a two-wire interface at the customer's premises. However, when terminated two-wire, simultaneous independent transmission cannot be supported because the two-wire interface combines the transmission paths into a single path.

Effective Two-Wire - a condition which permits the simultaneous transmission in both directions over a channel, but it is not possible to insure independent information transmission in both directions. Effective two-wire channels may be terminated with two-wire or four-wire interfaces.

End Office Switch - a local Telephone Company switching system where Telephone Exchange Service customer station loops are terminated for purposes of interconnection to trunks. Included are Remote Switching Modules and Remote Switching Systems served by a host office in a different wire center.

End User - any customer of an interstate or foreign telecommunications service that is not a carrier, except that a carrier other than a telephone company shall be deemed to be an "end user" when such carrier uses a telecommunications service for administrative purposes, and a person or entity that offers telecommunications services exclusively as a reseller shall be deemed to be an "end user" if all resale transmissions offered by such reseller originate on the premises of such reseller.

(This page filed under Transmittal No. 1149)

ACCESS SERVICE

2. General Regulations (Cont'd)

2.6 Definitions (Cont'd)

Entrance Facility - A Switched Transport facility that provides dedicated transport from the customer's point of termination to the Telephone Company serving wire center.

Entry Switch - See First Point of Switching

Envelope Delay Distortion - a measure of the linearity of the phase versus frequency of a channel.

Ethernet Virtual Connection (EVC)- A logical connection between the customer demarcation point and the Ethernet network.

Equal Level Echo Path Loss (ELEPL) - the measure of Echo Path Loss (EPL) at a four-wire interface which is corrected by the difference between the send and receive Transmission Level Point (TLP). [ELEPL = EPL - TLP (send) + TLP (receive)]

Expected Measured Loss - a calculated loss which specifies the end-to-end 1004-Hz loss on a terminated test connection between two readily accessible manual or remote test points. It is the sum of the inserted connection loss and test access loss including any test pads.

Exchange - a unit generally smaller than a Local Access and Transport Area, established by the Telephone Company for the administration of communications service in a specified area which usually embraces a city, town or village and its environs. It consists of one or more central offices together with the associated facilities used in furnishing communications service within that area. One or more designated exchanges comprise a given Local Access and Transport Area.

Exchange Termination - a PSN network component linking the access line and port termination.

Exit Message - an SS7 message sent to an end office by the Telephone Company's tandem switch to mark the Carrier Connect Time when the Telephone Company's tandem switch sends an Initial Address Message to an Interexchange Carrier.

Facility Signaling Point of Interconnection (FSPOI) - The term FSPOI denotes a Telephone Company-designated transport termination facility used in connection with the provisioning of a Dedicated Network Access Link (DNAL) used for STP Access. (N)
(N)
(N)

Field Identifier - two to four characters that are used on service orders to convey specific instructions. Field Identifiers may or may not have associated data. Selected Field Identifiers are used in Telephone Company billing systems to generate nonrecurring charges.

First-Come, First-Served - a procedure followed when the first service order received will be the first service order processed.

(This page filed under Transmittal No. 1697)

ACCESS SERVICE

2. General Regulations (Cont'd)

2.6 Definitions (Cont'd)

First Point of Switching - the first Telephone Company location at which switching occurs on the terminating path of a call proceeding from the customer premises to the terminating end office and, at the same time, the last Telephone Company location at which switching occurs on the originating path of a call proceeding from the originating end office to the customer premises.

Flexible Automatic Number Identification (Flexible ANI) - A Common Switching optional feature that provides additional values for the information indicator digits available with the ANI feature on originating calls. These additional digits are used for routing and billing purposes.

Frame Relay Service Access Point - a wire center location where an Ameritech Frame Relay service may be cross-connected to a customer's Special Access service using a Hubbed NNI Connection.

Frame Relay Service Point - a wire center location where UNI Connections and NNI Connections are available to customers.

Frequency Shift - the change in the frequency of a tone as it is transmitted over a channel.

Global Title Address Translation - software instructions in the Signal Transfer Point (STP) that identify the signaling message destination.

Grandfathered - Terminal Equipment, Multiline Terminating Systems and Protective Circuitry directly connected to the facilities utilized to provide services under the provisions of this tariff, and which are considered grandfathered under Part 68 of the F.C.C.'s Rules and Regulations.

Host Office - an electronic switching system which provides call processing capabilities for one or more Remote Switching Modules or Remote Switching Systems.

Host Subscriber – Customer with a multiplexed DS1, DS3 or SONET service who allows a Service User to occupy a channel or port of their multiplexed service through a Shared Network Arrangement.

Immediately Available Funds - a corporate or personal check drawn on a bank account and funds which are available for use by the receiving party on the same day on which they are received and include U.S. Federal Reserve bank wire transfers, U.S. Federal Reserve notes (paper cash), U.S. coins, U.S. Postal Money Orders and New York Certificates of Deposit.

Impedance Balance - the method of expressing Echo Return Loss and Singing Return Loss at a four-wire interface whereby the gains and/or loss of the four-wire portion of the transmission path, including the hybrid, are not included in the specification.

(N)
(N)
(N)

(This page filed under Transmittal No. 1551)

ACCESS SERVICE

2. General Regulations (Cont'd)

2.6 Definitions (Cont'd)

Impulse Noise - any momentary occurrence of the noise on a channel over a specified level threshold. It is evaluated by counting the number of occurrences which exceed the threshold.

Individual Case Basis - a condition in which the regulations, (if applicable) rates and charges for an offering under the provisions of this tariff are developed based on the circumstances in each Case.

Initial Address Message Delivery - a Common Switching Optional feature where an SS7 message sent in the forward direction to initiate trunk set up with the busying of an outgoing trunk that carries the information about that trunk along with other information relating to the routing and handling of the call to the next switch.

(Dx)
||
(Dx)

Inserted Connection Loss - the 1004 Hz power difference (in dB) between the maximum power available at the originating end and the actual power reaching the terminating end through the inserted connection.

x Issued under authority of Special Permission No. 92-964.

(This page filed under Transmittal No. 682)

2. General Regulations (Cont'd)

2.6 Definitions (Cont'd)

Interexchange Carrier (IC) or Interexchange Common Carrier - any individual, partnership, association, joint-stock company, trust, governmental entity or corporation engaged for hire in interstate or foreign communication by wire or radio, between two or more exchanges.

Intermediate Hub - denotes a wire center where multiplexing option is available for Direct High Capacity Services or Switched Transport Services (e.g., DS1, LT-3 Direct Transport), such that individual channels (e.g., VG, LT-1 Direct Transport) can be terminated at customer designated premises or switch(es) served by that wire center and/or individual channels (e.g., VG, LT-1 Direct Transport) can be extended through Telephone Company designated subtending wire center(s) to terminate at customer designated premises or switch(es) served by the subtending wire center.

Intermodulation Distortion - a measure of the nonlinearity of a channel. It is measured using four tones, and evaluating the ratios (in dB) of the transmitted composite four-tone signal power to the second-order products of the tones (R2), and the third-order products of the tones (R3).

Internet Protocol (IP) Dedicated Access Connection - denotes a dedicated high speed connection such as; High Speed (384 Kbps or higher download speed) Cable Modem, DSL Line, Dedicated T1 to the internet, Dedicated DS3 to the internet or other dedicated IP private line.

Internet Protocol (IP) Enabled Voice Information Service (IP-VIS) Dedicated Location - denotes a unique space owned or controlled by an IP-VIS provider, its agent or designee where the IP-VIS provider has located its media gateway used for IP-VIS or where the IP-VIS provider has located transmission facilities used for IP-VIS.

Internet Protocol (IP) Enabled Voice Information Service (IP-VIS) - denotes Internet Protocol (IP) voice information services and applications provided over an IP network and their associated capabilities and functionalities that enable an IP-VIS user to send or receive a communication based on Internet Protocol. IP-VIS Service is service between a provider of Internet Protocol (IP) enabled voice information services and the IP-VIS user only.

Internet Protocol (IP) Enabled Voice Information Service (IP-VIS) Off Net Traffic - denotes IP-VIS Traffic originating from IP-VIS Users terminating traffic to non-Telephone Company End Users subtending Telephone Company Access Tandems via the TIPToP one way port interface.

IP Enabled Voice Information Service (IP-VIS) On Net Traffic - denotes IP-VIS Traffic originating from IP-VIS Users and terminating to Telephone Company users via the TIPToP one way port interface.

IP Enabled Voice Information Service (IP-VIS) Traffic - denotes any traffic that originates from or terminates to an IP-VIS User at an IP-VIS User Site. Also the traffic must travel on an Internet Protocol Network, and provide an accurate and dialable CPN as part of the call record, that when dialed, will reach that specific IP-VIS User, on their Internet Protocol Network at their IP-VIS User Site.

Certain material previously appeared on this page now appears on 7th Revised Page 65.1

(N)

(N)

(This page filed under Transmittal No. 1425)

2. General Regulations (Cont'd)

2.6 Definitions (Cont'd)

IP Enabled Voice Information Service (IP-VIS) User - denotes a person utilizing a phone set dedicated for IP use for all voice traffic on the Internet Protocol Network at the IP-VIS User Site, and has an accurate and dialable CPN that when dialed, will reach the IP-VIS User on their Internet Protocol Network at their IP-VIS User Site.

IP Enabled Voice Information Service (IP-VIS) User Site - denotes the specific temporary or permanent premises where a specific communication is initiated or received by the IP Enabled Voice Information Service (IP-VIS) User, using Internet Protocol.

Internet Protocol (IP) Gateway - denotes a device that converts communications from Time Division Multiplexing (TDM) to Internet Protocol (IP).

Internet Protocol (IP) Network - denotes a network that carries traffic in Internet Protocol on an IP Dedicated Access Connection between the IP-VIS User Site and the IP Gateway and does not change the protocol to any other protocol between the IP-VIS User Site and the IP Gateway.

Interstate Communications - both interstate and foreign communications.

Intrastate Communications - any communications within a state subject to oversight by a state regulatory commission as provided by the laws of the state involved.

L Band - 1565-1605 nanometers (unit of spatial measurement that is one billionth of a meter).

Line Information Data Base (LIDB) - a data base used to validate Local Exchange Company Calling Card numbers or obtain Billed Number Screening data.

Line-Side Connection - a connection of a transmission path to the line side of a local exchange switching system.

Local Calling Area - a geographical area, as defined in the Telephone Company's Local and/or General Exchange Service tariff, in which an end user (Telephone Exchange Service subscriber) may complete a call without incurring MTS charges.

Local Access and Transport Area (LATA)- a geographic area established for the provision and administration of communications service. It encompasses one or more designated exchanges, which are grouped to serve common social, economic and other purposes.

Local Routing Number (LRN) - a 10-digit number used to uniquely identify a switch that has ported numbers.

Local Tandem Switch - a local Telephone Company switching unit by which local or access telephonic communications are switched to and from an End Office Switch.

Certain material appearing on this page previously appeared on 6th Revised Page 65.

(T)

(This page filed under Transmittal No. 1429)

2. General Regulations (Cont'd)

2.6 Definitions (Cont'd)

Loop Around Test Line - an arrangement utilizing a Telephone Company central office to provide a means for making two-way transmission tests on a manual basis. This arrangement has two central office terminations, each reached by means of separate telephone numbers and does not require any specific customer premises equipment. Equipment subject to this test arrangement is at the discretion of the customer.

Loss Deviation - the variation of the actual loss from the designed value.

Major Fraction Thereof - is any period of time in excess of 1/2 of the stated amount of time. As an example, in considering a period of one hour, a major fraction of one hour would be 31 minutes. Therefore, if a given service is interrupted for one hour and 31 minutes, the customer would be given a credit for two hours. For one hour and 30 minutes or less, the customer would be given credit for one hour.

Maritime Radio Common Carriers (MRCCs) - carriers which are regulated under Part 81 of the Federal Communications Commission's Rules and Regulations.

Message - a "Call" as defined preceding.

Milliwatt (102 Type) Test Line - an arrangement in an end office which provides a 1004 Hz tone at 0 dBm0 for one-way transmission measurements towards the customer's premises from the Telephone Company end office.

Mobile Switching Center (MSC) - is the location of the switch in a cellular telephone network used by a Commercial Mobile Radio Service (CMRS) provider in performing, *inter alia*, terminating and originating functions for calls to and from a CMRS provider's end users.

Media Access Control (MAC) Address- A data link layer protocol that defines how packets are transmitted on a local area network.

Modification of Final Judgement (MFJ) - the consent decree approved by the U.S. District Court in United States versus Western Electric 552 F. Supp. 171 (To D.C. 1982).

Multicast Traffic – Ethernet frames that are forwarded to multiple destinations that are identified using a multicast group address.

Multi-Point Distribution Service - the multi-point distribution of pay television programming via microwave broadcast transmission equipment.

(Nx)
(Nx)

N-1 Carrier - in Local Number Portability Query Service, the telecommunications carrier immediately preceding the terminating carrier.

Network Control Signaling - the transmission of signals used in the telecommunications system which perform functions such as supervision (control, status, and charge signals), address signaling (e.g., dialing), calling and called number identifications, rate of flow, service selection error control and audible tone signals (call progress signals indicating re-order or busy conditions, alerting, coin denominations, coin collect and coin return tones) to control the operation of the telecommunications system.

(x) Issued under the Authority of Special Permission No. 05-017 of the FCC.

(This page filed under Transmittal No. 1457)

ACCESS SERVICE

2. General Regulations (Cont'd)

2.6 Definitions (Cont'd)

Network Interface - the point of interconnection between telephone company communications facilities and terminal equipment, protective apparatus or wiring at a subscriber's premises. The network interface or demarcation point shall be located on the subscriber's side of the telephone company's protector, or the equivalent thereof in cases where a protector is not employed, as provided under the local telephone company's reasonable and nondiscriminatory standard operating practices.

Network Terminal Number (NTN) - in PSN service, numeric character sequence used to identify the originating and terminating locations of each user's DTE.

Network User Identification (NUI) Code - in PSN service, a character string, with structure defined by the Telephone Company, used as a log-in ID.

Non-Competitive County - The term "Non-Competitive County" denotes the geographic unit of a county or county-equivalent that neither is competitive pursuant to the F.C.C.'s competitive market test nor was subject to Phase II, Level 2 pricing flexibility prior to June 1, 2017. (N)
(N)
(N)

Non IP Enabled Voice Information Service (IP-VIS) Traffic - denotes any traffic not specifically defined as or not identifiable as IP-VIS traffic or any traffic that does not travel on an IP Dedicated Access Connection or any traffic that is not in Internet Protocol, for any portion of the communication between the IP-VIS User and the IP Gateway device, or any traffic from a Non IP-VIS User, or any traffic from a user site that is not an IP-VIS User Site, or any traffic classified by this tariff as Non IP-VIS traffic.

Non IP Enabled Voice Information Service (IP-VIS) User – any user(s) not meeting the definition of an IP-VIS User.

Non IP Enabled Voice Information Service (IP-VIS) Off Net Traffic - denotes Non IP-VIS Traffic between a user (IP-VIS or non IP-VIS users) or customer (TIPToP or non TIPToP customers) and non-Telephone Company (Off Net) End Users via a TIPToP port interface.

Non IP Enabled Voice Information Service (IP-VIS) On Net Traffic - denotes Non IP-VIS Traffic between a user (IP-VIS or non IP-VIS users) or customer (IP or non IP customers) and Telephone Company users via a TIPToP port interface.

Nonsynchronous Test Line - an arrangement in step-by-step end offices which provides operational tests which are not as complete as those provided by the synchronous test lines, but can be made more rapidly.

North American Numbering Plan (NANP) - a three-digit area (Numbering Plan Area) code and a seven-digit telephone number made up of a three-digit Central Office code plus a four-digit station number.

Off-hook - the active condition of Switched Access or a Telephone Exchange Service line.

Off Net End User - denotes a non-Telephone Company end user that subtends a Telephone Company Access Tandem.

On-hook - the idle condition of Switched Access or a Telephone Exchange Service line.

(This page filed under Transmittal No. 1864)

2. General Regulations (Cont'd)

2.6 Definitions (Cont'd)

Open Circuit Test Line - an arrangement in an end office which provide an ac open circuit termination of a trunk or line by means of an inductor of several Henries.

Operational Expanded Interconnection - Ameritech Interconnection Service (as described in Section 16 following) is considered operational expanded interconnection when a customer has taken Ameritech Cross-Connection Service for Interconnection (as described in Section 16.4 following) in a state.

Operational Switched Cross-Connection - Switched Cross-Connection Service (as described in Section 16.4 following) is considered operational switched cross-connection when customers have taken either 100 DS1-equivalent switched transport cross-connects in the zone 1 offices (as identified in Section 6.10 following) in a state or have taken an average of 25 DS1-equivalent switched transport cross-connects per zone 1 office in a state.

Operator Services Access Point - locations where Telephone Company switches are provided for an Operator Services System for the provision of operator services.

Operator Services System - a grouping of Telephone Company switches and operator positions used for operator services for a specific geographic area.

Optical Line Termination (OLT) - an arrangement that converts an optical signal to one or more 4-wire electrical interfaces (operating at a terminating bit rate of 44.736 Mbps).

Originating Direction - the use of access service for the origination of calls from an End User premises to a customer premises.

(M)

(M)

Certain material appearing on this page previously appeared on 7th Revised Page 66.1

(This page filed under Transmittal No. 1425)

ACCESS SERVICE

2. General Regulations (Cont'd)

2.6 Definitions (Cont'd)

Originating Point Code - a field within a signaling message that identifies the originating network signaling node.

OZZ Code - codes that are used to route certain types of traffic to specific trunk groups such as, specific IC trunk groups, TOPS Trunk Groups, etc.

Packet Delivery Rate (PDR)- Defined as the actual amount of useful and non-redundant information that is transmitted or processed from end-to-end across the Ethernet network. It is a function of bandwidth, error performance, congestion and other factors. PDR will be defined as a percentage of Ethernet frames offered to the network that successfully traverse the network, end-to-end, within the Committed Information Rate (CIR), and within a calendar month. Packet delivery is measured by averaging sample measurements taken during a calendar month from NTE to NTE to which the customer ports are attached.

Pay Telephone Facilities - Telephone Company provided facilities that are available to pay telephone service providers.

Parameter - That portion of an SS7 message that identifies a specific function.

Percentage for Interstate Use (PIU) - Interstate jurisdictional use of an access service as reported by the customer. This percentage is stated as a whole number percentage (either 0 or 100 percent for Special Access, and a number of 0 through 100 percent for Switched Access) which is the customer's best estimate of the percentage of the total use of the service that will be interstate in nature.

Phase Jitter - the unwanted phase variations of a signal.

Point of Termination - the point of demarcation within a customer-designated premises at which the Telephone Company's responsibility for the provision of Access Service ends.

Port Termination - an interface on the PAD or packet switch that provides an entry point into the PSN.

Premises - a building, a portion of a building in a multitenant building or buildings on continuous property (except Railroad Right-of-Way, etc.) not separated by a public thoroughfare.

Prime Service Vendor - denotes status of Telephone Company when contracting directly with end user to offer Telecommunications Service Priority.

Private Network - a network owned or controlled by a single customer or closed group of customers (i.e., not available to the general public) which connects two or more premises and is used to transport interstate traffic. The premises must be separated by a public thoroughfare or right of way. Examples of a private network are: 1) one or more interstate private line(s) interconnected to a customer provided switch; 2) a common control switching arrangement (CCSC); or 3) Enhanced Private Switched Communications System (EPSCS). A private network may not use any part of the public switched network.

(x) Issued under authority of Special Permission No. 03-101 of the FCC.

(Nx)

(Nx)

(This page filed under Transmittal No. 1370)

ACCESS SERVICE

2. General Regulations (Cont'd)

2.6 Definitions (Cont'd)

Public Switched Digital Service - a switched access optional feature which provides for data transmission at up to 56 kilobits per second.

Query - a signaling message requesting processing instructions or service data contained in a centralized data base.

Query, Default - In Local Number Portability (LNP) Query Service, a signaling message requesting the Local Routing Number (LRN) contained in the LNP Data Base for which a query has not yet been performed by the N-1 Carrier and where the N-1 carrier has not prearranged with the Telephone Company to have the queries performed on the N-1 carrier's behalf.

(N)
|
(N)

Radio Common Carriers (RCCs) - carriers which are regulated under Part 22 of the Federal Communications Commission's Rules and Regulations.

Recipient Switch - denotes any end office switch that serves Directory Numbers (DN) within a number portable NXX that is not originally assigned to the switch. Customers assigned a DN within the indicated NXX that were working out of a switch other than the one originally designated are said to have ported their number to this recipient switch.

(N)
|
(N)

Regional Service Management System/Number Portability Administration Center - denotes the third party administered database which maintains the information on all ported numbers in the Telephone Company's region.

Release Message - an SS7 message sent in either direction to indicate that the specific circuit is being released.

Registered Equipment - the customer's premises equipment which complies with and has been approved within the Registration Provisions of Part 68 of the F.C.C. Rules and Regulations.

Remote Switching Modules and/or Remote Switching Systems - are small, remotely controlled electronic end office switches which obtain their call processing capability from an ESS type Host Office. Some Remote Switching Modules and/or Remote Switching Systems may or may not be able to accommodate direct trunks to a customer.

Return Loss - a measure of the similarity between the two impedances at the junction of two transmission paths. The higher the return loss, the higher the similarity.

(This page filed under Transmittal No. 1149)

2. General Regulations (Cont'd)

2.6 Definitions (Cont'd)

Ring Extension - a customer premises SONET installation connected to OC-12 Dedicated Ring or OC-48 Dedicated Ring Service via Dedicated Ring Nodes and Ports at two different wire center locations one of which must be the serving wire center of the extended location. This applies only when the 1+1 Protection with Central Office Survivability optional feature is offered with OC-3 Service or OC-12 Service Local Distribution Channels.

Route Miles - are the total of cable sheath feet shown in the Telephone Company's location records from the demarcation point at the customer's premises to the serving wire center. This total footage is divided by 5,280 feet and then shown out two decimal places and rounded to the next higher quarter route mile. This is for per quarter route mile billing.

Service Code - an SS7 parameter that allows individual calls to be identified and routed based on specific service characteristics.

Service Control Point - a centralized database which contains Common Channel Signaling Signaling System 7 service data. The SCP is divided into a database node and its associated data bases. The SCP contains the Line Information Data Base and the 800 Data Base.

Service Interface - is that point of termination where all tariffed technical/physical parameters are defined. The Service Interface is located at the Network Interface or may be extended at the customer's request.

Service Switching Point - an end office or tandem switch equipped with the signaling link hardware and software that can perform the Signal Point functions. In addition, SSPs can identify the need for application software in processing a Common Channel Signaling Signaling System 7 call and request and respond to call processing instructions issued by a Service Control Point.

Service User – Customer who has their service on a channel or port of a multiplexed DS1, DS3 or SONET service belonging to a Host Subscriber through a Shared Network Arrangement.

Serving Wire Center - the central office in the wire center building which would normally serve the customer location with basic exchange service.

Seven Digit Manual Test Line - an arrangement which allows the customer to select balance, milliwatt and synchronous test lines by manually dialing a seven digit number over the associated access connection. (N)
(N)
(N)

Shared Network Arrangement - a service offering whereby a Service User may connect subtending services to a Host Subscriber's multiplexed DS3, DS1 or SONET service, and the Telephone Company will undertake to maintain separate customer records and billing.

(N)

(This page filed under Transmittal No. 1551)

2. General Regulations (Cont'd)

2.6 Definitions (Cont'd)

Short Circuit Test Line - an arrangement in an end office which provides for an ac short circuit termination of a trunk or line by means of a capacitor of at least four microfarads.

Signal Point - an end office or tandem switch equipped with signaling link hardware and software that can perform trunk signaling (call set up).

Signal Transfer Point - a specialized packet switch that routes and translates signaling messages in the Common Channel Signaling network.

Signal-to-C-Notched Noise Ratio - the ratio in dB of a test signal to the corresponding C-Notched Noise.

Signaling System Seven - the layered protocol used for standardized Common Channel Signaling in the United States.

Singing Return Loss - the frequency weighted measure of return loss at the edges of the voiceband (200 to 500 Hz and 2500 to 3200 Hz), where singing (instability) problems are most likely to occur.

Special Order - an order for a Billing and Collection Service or an order for a Directory Assistance Service.

Storage Area Network (SAN) – network which links host computers, storage servers and systems.

Subcontractor - denotes status of Telephone Company when contracting directly with a Prime Service Vendor to offer Telecommunications Service Priority.

Subtending End Office of an Access Tandem - an end office that has final trunk group routing through the tandem.

Synchronous Optical Network (SONET) - is a set of international standards for fiber optic based transmission systems. SONET defines standard optical carrier transmission rates and utilizes a modular multiplexing approach based on the application of Synchronous Transport Signals (STS).

Synchronous Test Line - an arrangement in an end office which performs marginal operational tests of supervisory and ring-tripping functions.

Synchronous Transport Signal (STS-1) - a 51.84 Mbps signal within a SONET optical carrier signal. The STS-1 signal consists of overhead and synchronous payload envelope (SPE). The overhead part of the signal is used for controlling, framing and maintaining the signal. The SPE is used to transport the customer's data.

Tandem Signaling - a Feature Group D Optional Feature that provides the Carrier Identification Code (CIC) and the 0ZZ code or the SS7 equivalent from Telephone Company end offices required to provide third-party tandem switching services. (D)

(This page filed under Transmittal No. 1821)

2. General Regulations (Cont'd)

2.6 Definitions (Cont'd)

Tandem-Switched Transport - Switched Transport provided between the customer's serving wire center and end offices that subtend the tandem or between an access tandem and end offices that subtend the tandem. Tandem-Switched Transport is switched at a tandem switch. Tandem-Switched Transport consists of circuits dedicated to the use of a single customer from the serving wire center to the tandem and circuits used in common by many customers from the tandem to the end office.

Tandem-Switched Transport Facility - A Switched Access transport facility used for Tandem-Switched Transport.

Telecommunications Relay Services (TRS) - Telephone transmission services that enable two-way communication between an individual who uses a text telephone or other nonvoice terminal device and an individual who does not use such a device.

Terminating Direction - the use of Access Service for the completion of calls from a customer premises to an End User premises.

Terminus Hub - denotes a wire center where multiplexing option is available for Direct High Capacity Services (e.g., DS1), such that individual channels (e.g., VG) are terminated at customer designated premises served by that wire center.

Text Telephone (TT) - A machine that employs graphic communication transmission of coded signals through wire or radio communication system.

Third Party Host – Customer who has a Shared Network Arrangement with a Host Subscriber, and allows a Cascading Service User to occupy a channel or port of the Third Party Host's multiplexed service through a Cascading Shared Network Arrangement.

Transit Network Selection - an SS7 parameter whose purpose is to indicate to an intermediate node or a network what carrier and circuit group is to be selected.

(N)
(N)
(N)

(This page filed under Transmittal No. 1551)

2. General Regulations (Cont'd)

2.6 Definitions (Cont'd)

Transmission Measuring (105 Type) Test Line/Responder - an arrangement in an end office which provides far-end access to a responder and permits two-way loss and noise measurements to be made on trunks from a near end office.

Transmission Node - denotes a location in a Telephone Company Central Office served by a customer's fiber optic cable or microwave facilities as specified in Section 16, following.

Transmission Path - an electrical path capable of transmitting signals within the range of the service offering, e.g., a Direct Analog Service transmission path is capable of transmitting voice frequencies within the approximate range 300 to 3000 Hz. A transmission path is comprised of physical or derived channels consisting of any form or configuration of facilities typically used in the telecommunications industry.

TRS Provider - the one authorized provider of telecommunications relay functions in each state.

Trunk - a communications path connecting two switching systems in a network, used in the establishment of an end-to-end connection.

Trunk Group - a set of trunks which are traffic engineered as a unit for the establishment of connections between switching systems in which all of the communications paths are interchangeable.

Trunk Side Connection - the connection of a transmission path to the trunk side of a local exchange switching system.

Two-Wire to Four-Wire Conversion - an arrangement which converts a four-wire transmission path to a two-wire transmission path to allow a four-wire facility to terminate in a two-wire entity (e.g., central office switch).

Unbundled Network Elements (UNEs)⁽¹⁾ - Denotes the network elements the Telephone Company is required to provide on an unbundled basis pursuant to Section 251(c)(3) of the Communications Act of 1934, as amended.

Unicast Traffic – Ethernet frames forwarded from one station to another using the individual address.

(Nx)
(Nx)

Uniform Service Order Code (USOC) - a three or five character alphabetic, numeric, or an alphanumeric code that identifies a specific item of service or equipment. Uniform Service Order Codes are used in the Telephone Company billing system to generate recurring rates and nonrecurring charges.

⁽¹⁾ In the event the Commission or a court, pursuant to any regulatory or judicial review of the Commission's *Review of the Section 251 Unbundling Obligations of Incumbent Local Exchange Carriers*, Report and Order and Order on Remand and Further Notice of Proposed Rulemaking, CC Docket No. 01-338, FCC 03-36, para. 581 (released Aug. 21, 2003) (*Triennial Review Order*), vacates, stays, remands, reconsiders, or rejects the portion of the Triennial Review Order requiring ILECs to permit commingling, the terms and conditions of this tariff authorizing commingling, which are identified with a footnote, shall cease to be effective as of the effective date of the Commission order or the issuance of the court's mandate. In that event, the Telephone Company will provide customers that have commingled UNE(s) and/or UNE Combination(s) with wholesale services obtained under this Tariff written notice that, within 30 days, customers must either convert such UNE(s) or UNE Combination(s) to a comparable service, or disconnect such UNE(s) and/or UNE Combination(s) from those wholesale services. Failure to provide the Telephone Company instructions to convert or disconnect such UNE(s) and/or UNE Combination(s) within 30 days, as described above, shall be deemed authorization to convert the UNE(s) and/or UNE Combination(s) to comparable access services at month-to-month rates.

(x) Issued under the Authority of Special Permission No. 05-017 of the FCC.

(This page filed under Transmittal No. 1457)

2. General Regulations (Cont'd)

2.6 Definitions (Cont'd)

Unknown Unicast Traffic – Ethernet frames that contain a destination address that has not been “learned” by the network equipment for an address with no dynamic filtering entry present.

User Service Information - an SS7 parameter which may be coded to indicate any one of four circuit mode bearer capabilities.

V and H Coordinates Method - a method of computing airline miles between two points by utilizing an established formula which is based on the vertical and horizontal coordinates of the two points.

Virtual Tributary (VT1.5) - a 1.728 Mbps signal channel within a SONET STS-1 signal channel. The VT1.5 signal consists of overhead and a Synchronous Payload Envelope (SPE). The overhead part of the signal is used for controlling, framing and maintaining the signal. The VT1.5 SPE is used to transport the customer's service, which typically consists of a DS1 service signal.

WATS Serving Office - a Telephone Company designated serving wire center where switching, screening and/or recording functions are performed in connection with the closed-end of WATS or WATS-Type services.

Wide Area Network Physical Transport (WAN-PHY) – an Ethernet standard for wide area network transport at the physical layer, with a maximum bit rate of 9.953 Gbps.

Wire Center - a building in which one or more central offices, used for the provision of Telephone Exchange Services, are located.

(N)
(N)

(This page filed under Transmittal No. 1527)