

20. MegaLink Custom Services

20.1 General Description

MegaLink Custom Service is a special access service utilizing DS3 technology to provide dedicated high capacity transport between customer designated premises*, either directly or through a Telephone Company Hub where bridging, multiplexing, Transport Resource Management Service, or Network Reconfiguration Service functions are performed. (Transport Resource Management Service and Network Reconfiguration Service, as set forth in Section 18, work in conjunction with MegaLink Custom Service, allowing customers the ability to reconfigure their circuits.) The DS3 signal provides for the transmission of nominal 44.736 Mbps isochronous serial data. MegaLink Custom Services are provided (1) between two customer designated premises, (2) between a customer designated premises and a Telephone Company Hub Central Office, (3) between a Telephone Company Hub Central Office and a Transport Resource Management Service Hub, (4) between Transport Resource Management Service Hubs at 44.736 Mbps transmission, (5) between Network Reconfiguration Service Hubs at 44.736 Mbps transmission, (6) between a Network Reconfiguration Service Hub and a Transport Resource Management Service Hub at 44.736 Mbps transmission, (7) between a Network Reconfiguration Service Hub and a Telephone Company Hub at 44.736 Mbps transmission, or (8) between a Telephone Company Hub Central Office and a ReliaNet Node, for interconnection with High Capacity Services or other MegaLink Custom Services. MegaLink Custom Services may include Optional Features, BSEs and Functions.

MegaLink Custom Service offers the customer the option of requesting either an electrical or optical interface at their premises. The interface at a Telephone Company Hub Central Office is electrical.

Customers requesting electrical interface will receive an electrical signal with a transmission speed of 44.736 Mbps per channel. Compatible channel interfaces are set forth in Technical Reference Publication TR-INS-000342.

Rates and charges for MegaLink Custom Services are set forth in Section 20.5 following, with the exception of the services provided by the Telephone Company in the Metropolitan Statistical Areas (MSAs) in which the Telephone Company has received Phase II pricing flexibility pursuant to Subpart H of Part 69 of the Commission's Rules. The rates and charges for the Optical Carrier Network (OCN) Point-to-Point Service in the MSAs that have received Phase II pricing flexibility are set forth in Section 39.

*Telephone Company Centrex CO-like switches and Telephone Company Answering Service Concentrators are considered to be customer premises for purposes of administering regulations and rates contained in this tariff.

20. MegaLink Custom Services (Cont'd)

20.1 General Description (Cont'd)

Customers requesting an optical interface will receive (an) optical signal(s) at the transmission speed(s) associated with the equivalent number of DS3s requested on the Access Order. The transmission speeds for optical interfaces are stated as approximate multiples of 44.736 Mbps.

Technical specifications for MegaLink Custom Services may be found in the following Technical Reference Publications:

Technical Reference PUB 76625
Technical Reference TR-INS-000342

It is the customer's responsibility to arrange for the Network Channel Terminating Equipment associated with the high capacity channel at the customer's premises.

The four basic rate categories which apply to MegaLink Custom Service are Channel Termination, Interoffice Mileage, Service to Service Through Connect Arrangements and Optional Features and Functions. Channel Termination provides for the communications path between a customer designated premises and the serving wire center for that premises or for the communications path within a building which connects a customer's facilities with a customer designated premises without routing through the serving wire center. Interoffice Mileage provides for the transmission facilities between the serving wire centers associated with two customer designated premises, between a serving wire center and a Telephone Company Hub Central Office or, in the case of a Service Extension, between two Telephone Company Hub Central Offices. The Service to Service Through Connect Arrangement rate category provides for an interconnection of two MegaLink Custom Services or a MegaLink Custom Service and a DTL associated with STN Service in the same Telephone Company Hub Central Office. The Optional Features, BSEs and Functions rate category provides for optional features and functions which may be added to a MegaLink Custom Service to improve its quality or utility to meet specific communications requirements.

Loop Redundancy⁽¹⁾, which provides automatic restoration of the Megalink Custom Service Channel Termination and physical route redundancy between the customer's premises and the customer's serving wire center in the event of a single loop failure, will be provided on Megalink Custom Channel Terminations in those situations where the customer's premises and serving wire center are equipped with the necessary equipment and facilities. If the equipment and facilities are not available, the interval for loop redundancy will be within 2 years from the date of customer request or the agreed upon date if Special Construction applies.

- (1) As of the effective date of the tariff, by the end of 1997, all but 100 of the current MegaLink Custom lines in SWBT territory will be served from wire centers providing Loop Redundancy (with basic DS3 service).

20. MegaLink Custom Services (Cont'd)

20.1 General Description (Cont'd)

The following describes the service configurations available for MegaLink Custom Service.

Customer Designated Premises to Telephone Company Hub Central Office

Electrical Interface

This service configuration provides electrical DS3 signals at the customer designated premises and the Telephone Company Hub Central Office.

Example:

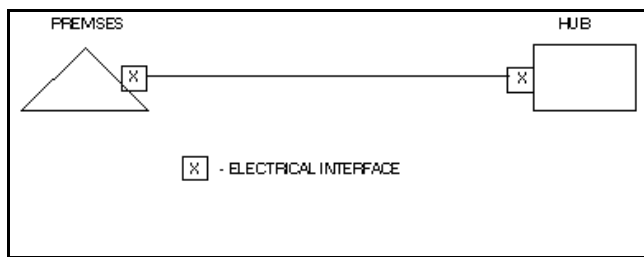

Optical Interface

This service configuration provides optical signals at the customer designated premises and electrical DS3 signals at the Telephone Company Hub Central Office.

Example:

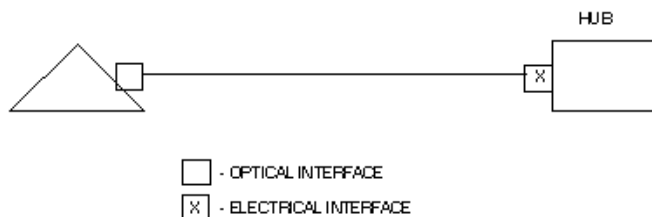

20. MegaLink Custom Services (Cont'd)

20.1 General Description (Cont'd)

Customer Designated Premises to Customer Designated Premises

Electrical Interface to Electrical Interface

This service configuration provides electrical DS3 signals at both customer designated premises.

Example:

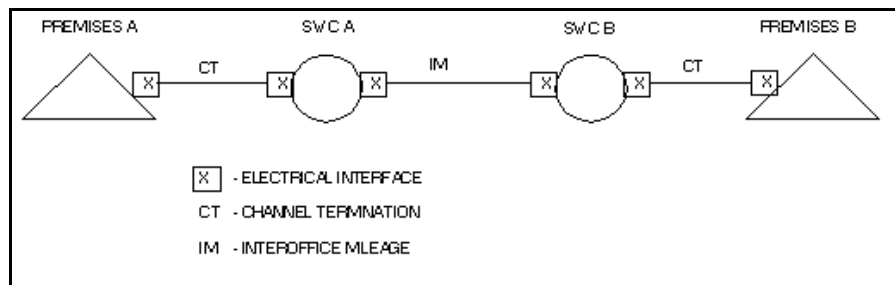

Optical Interface to Electrical Interface

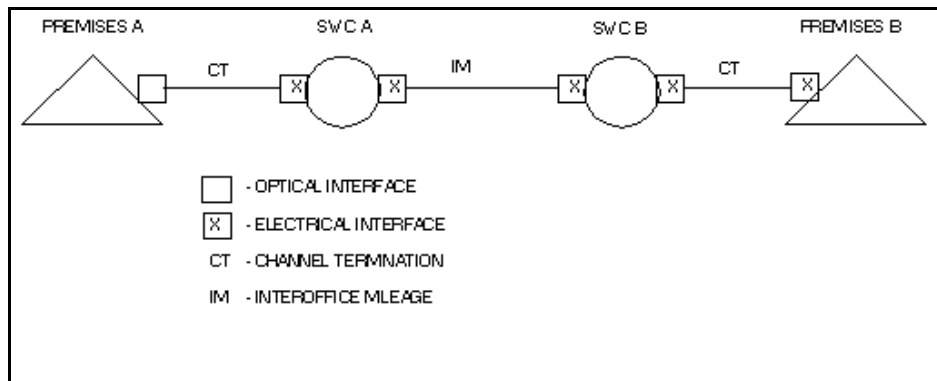

at one

20. MegaLink Custom Services (Cont'd)

20.1 General Description (Cont'd)

Service to Service Through Connect Arrangement

The Service to Service Through Connect Arrangement provides for an interconnection of two MegaLink Custom Services, a MegaLink Custom Service and a Digital Transmission Link (DTL) associated with a Self-healing Transport Network (STN), or MegaLink Custom Service and ReliaNet DS3 Access Ports in the same Telephone Company Hub Central Office.

Example:

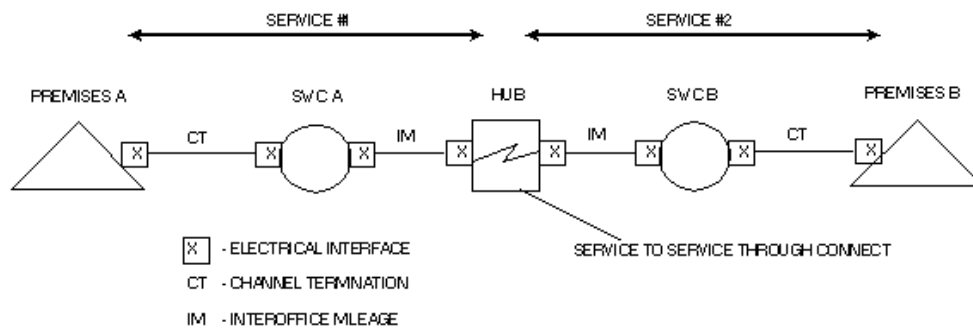

MegaLink Custom Service offers the customer Portability on existing services under certain provisions as set forth in Section 20.4 following. Portability is the ability to move MegaLink services to another location without incurring Termination Liabilities.

0. MegaLink Custom Services (Cont'd)

20.2 Optional Feature, BSE and Function Descriptions

20.2.1 Central Office Multiplexing BSE

DS3 to DS1 multiplexing provides an arrangement in a Telephone Company Hub Central Office that converts a DS3 signal to 28 DS1 channels using digital time division multiplexing.

When ordering multiplexing, the customer will select the designated hub(s) and subtending wire center(s) from the National Exchange Carriers Association, Inc. Tariff F.C.C. No. 4 Subtending Wire Center section(s) and Wire Center section(s). A description of the types of multiplexing hubs are as set forth in 7.1.3(B)(3) (Intermediate Multiplexing Hub), 7.1.3(B)(4) (Super Intermediate Multiplexing Hub) and 7.1.3(B)(5) (Terminus Multiplexing Hub) preceding.

20.2.2 SecureNet

SecureNet options provide MegaLink Custom Service with automatic restoration capabilities which prevent service interruption in the event of a single facility break or a single electronics failure. SecureNet options are available only where fiber optic facilities are used to provide the underlying MegaLink Custom Service.

The automatic restoration capabilities are provided through the use of intelligent components which are capable of sensing a transmission failure and by separately routing the primary transmission path and secondary transmission path in geographically separate fiber optic cables. In the event of a transmission failure, the intelligent components will automatically switch the MegaLink Custom Service to either the primary or secondary path within 2.0 seconds.

The primary and secondary transmission paths for MegaLink Custom Service will be routed in geographically separate fiber optic cables up to the nearest point to the customer's premises that route redundancy can be achieved.

20. MegaLink Custom Services (Cont'd)

20.2 Optional Feature, BSE and Function Descriptions (Cont'd)

20.2.2 SecureNet (Cont'd)

In the event a facility break occurs in that portion of the service for which route redundancy could not be achieved, the Telephone Company cannot guarantee automatic restoration of the customer's service within 2.0 seconds and a credit as set forth for SecureNet in Section 2.5.5(B) (When A Credit Allowance Applies) will not apply.

SecureNet options are only available with MegaLink Custom Service, with electrical interfaces at the customer's premises. SecureNet options are available at those serving wire centers where equipment and facilities are available. Hub Redundancy and Serving Wire Center and Facility Redundancy will be provided in those serving wire centers found in the National Exchange Carrier Association, Inc. Tariff F.C.C. No. 4. Technical specifications may be referenced in Technical Reference TP 76625 and in Technical Reference TR-INS-000342.

SecureNet is provided with three options allowing for various levels of self-healing capabilities.

(A) Hub Redundancy

This option provides automatic restoration and physical route redundancy from the customer's premises to the customer's DS3/DS1 multiplexing hub in the event of a single loop, wire center, interoffice facility or hub failure.

Hub Redundancy is only available for MegaLink Custom Service, with electrical interfaces at the customer's premises, provided from a customer's premises to a DS3/DS1 multiplexing hub office. The MegaLink Custom Service must be equipped with a DS3 to DS1 Central Office Multiplexing arrangement. The Hub Redundancy option includes the multiplexing capabilities provisioned on the secondary transmission path at the redundant DS3/DS1 multiplexing hub office. The serving wire center and multiplexing hub may be collocated. This option includes interoffice mileage for the redundant facility.

Hub Redundancy is available where more than one exchange telephone company is involved (i.e., jointly provided service) when those telephone companies have agreed upon facilities and terms and conditions of the jointly provided service.

20. MegaLink Custom Services (Cont'd)

20.2 Optional Feature, BSE and Function Descriptions (Cont'd)

20.2.2 SecureNet (Cont'd)

(B) Serving Wire Center and Facility Redundancy

This option provides automatic restoration and physical route redundancy from the customer's premises to the customer's Telephone Company Hub Central Office or from the customer's premises to another premises in the event of a single loop, wire center or interoffice facility failure. The customer's serving wire center and Telephone Company Hub Central Office are separate locations. This option includes interoffice mileage for the redundant facility.

Serving Wire Center and Facility Redundancy is available where more than one exchange telephone company is involved (i.e., jointly provided service) when those telephone companies have agreed upon facilities and terms and conditions of the jointly provided service.

20. MegaLink Custom Services (Cont'd)

20.2 Optional Feature, BSE and Function Descriptions (Cont'd)

20.2.3 Service Extension

An existing MegaLink Custom Service can be extended from the current Telephone Company Hub Central Office to another Telephone Company Hub Central Office via a Service Extension.

Example:

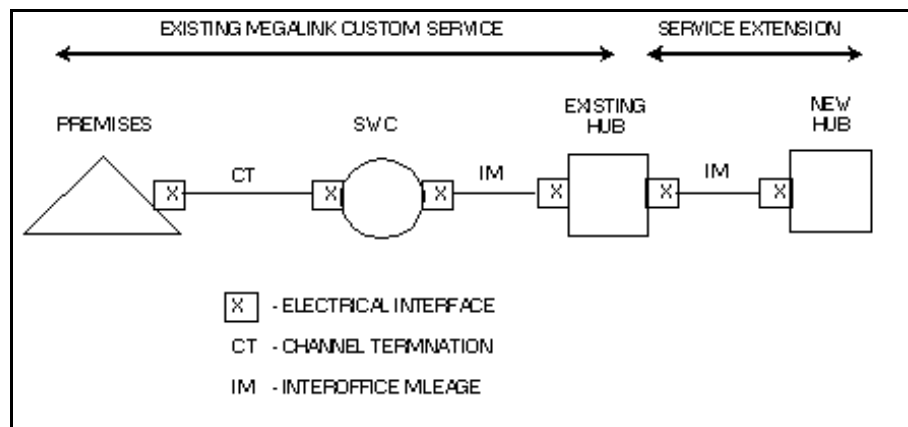

20. MegaLink Custom Services (Cont'd)

20.2 Optional Feature, BSE and Function Descriptions (Cont'd)

20.2.4 STN Interconnection with SecureNet Equipped MegaLink Custom Service

This option is provided for interconnection of an STN with MegaLink Custom Service equipped with the SecureNet Serving Wire Center and Facility Redundancy feature as set forth in 20.2.2(B) (Serving Wire Center and Facility Redundancy).

20.2.5 C-Bit Parity Framing Format Option

C-Bit Parity Framing Format Option (C-Bit) allows customers to specify the C-Bit format rather than using the standard M13 multiplex format interface. C-Bit allows DS3 framing bits to be rearranged for additional performance monitoring capabilities by the customer. The performance monitoring capability is inherent to the customer's CPE. The Telephone Company does not monitor the C-Bits for performance or any other purpose.

C-Bit is available when MegaLink Custom Service is provided over SONET facilities from end to end. C-Bit is not available if the customer's MegaLink Custom Service:

- Is provided over asynchronous fiber, microwave radio, or other incompatible facility; or
- Utilizes multiplexing as described in Section 20.2.1

If C-Bit is ordered with new MegaLink Custom Service, the C-Bit nonrecurring charge does not apply. If C-Bit is ordered for existing MegaLink Custom Service and is available, a nonrecurring charge will apply as set forth in Section 20.5.7 (J) following.

Customers with existing MegaLink Custom service provided over incompatible facilities may order C-Bit if SONET facilities exist for the service route requested. SONET facilities are available at those serving wire centers where equipment and facilities exist, as found in the National Exchange Carrier Association, Inc. (NECA) Tariff F.C.C. No. 4. In this case, the customer must disconnect their existing service and order new service. Customers under an existing term pricing plan will not be charged a termination charge, provided the conditions contained in 20.4.6 following are met. All applicable nonrecurring charges for the new service will apply, however, the C-Bit nonrecurring charge will not apply for the new service being ordered as described above.

20. MegaLink Custom Services (Cont'd)

20.3 Service Provisioning

20.3.1 Design Layout Report

At the request of the customer, the Telephone Company will provide to the customer the make-up of the facilities and services provided under this tariff as MegaLink Custom Service to aid the customer in designing its overall service. This information will be provided in the form of a Design Layout Report. The Design Layout Report will be provided to the customer at no charge, and will be reissued or updated whenever these facilities are materially changed.

20.3.2 Acceptance Testing

At no additional charge, the Telephone Company will, at the customer's request, cooperatively test at the time of installation, the parameters contained in Technical Reference TP 76625.

In addition to the above tests, Additional Cooperative Acceptance Testing, to test other parameters not defined in Technical Reference TP 76625, is available at the customer's request. Charges as defined in Section 13.3.7 (Special Access, MegaLink Custom Service and STN Rates and Charges) will apply. All test results will be made available to the customer upon request.

20.3.3 Diversity

A customer may request that the facilities used to provide MegaLink Custom (DS3) services be specially routed. The regulations, rates and charges for Diversity are set forth in Section 27.

20. MegaLink Custom Services (Cont'd)

20.4 Rate Regulations

This section contains the specific regulations governing the rates and charges which may apply to MegaLink Custom Service.

The rates and charges in effect at the time the MegaLink Custom Service is installed and accepted by the customer are the rates and charges which will be billed to the customer requesting the service. The rates and charges in effect at that time may not be the same as those rates and charges in effect at the time the customer requests the service.

If the Telephone Company initiates rate changes resulting in a decrease of rates for an existing service with a 1, 3, 5 or 10 year^{(1) (2)} billing period, those rate changes will be passed along to the customer. Rate changes resulting in an increase of rates for an existing service with a 1, 3, 5 or 10 year^{(1) (2)} billing period will not exceed the original rate for that selected bill period. Rate changes may occur as a result of F.C.C. action.

Rates and charges (both monthly and nonrecurring) for Kansas MegaLink Custom Services (identified as Nonzoned) will be applied as contained in 20.5. Rates and charges for Arkansas, Missouri, Oklahoma and Texas will be applied based on Pricing Zones as contained in 20.5. The Pricing Zone for each serving wire center is as specified in the National Exchange Carrier Association, Inc. Tariff F.C.C. No. 4. Additionally, if the Channel Mileage crosses Pricing Zones (e.g., serving wire center 1 is in Pricing Zone 1 and serving wire center 2 is in Pricing Zone 2), the higher priced mileage rate will be applied to the entire channel mileage.

Effective November 1, 2017, Competitive Counties and Non-Competitive Counties have been established and are defined in Section 2.7 and the wire centers within such counties are listed in Sections 15.2(C) and (D).

For all rate elements other than End User channel terminations and their optional features,⁽⁴⁾ price flex rates and charges, as provided in Section 39.5.2, apply, regardless of whether the county is Competitive or Non-Competitive.

For End User channel terminations and their optional features,^{(3) (4)} the application of "price cap" or "price flex" is dependent upon whether or not the serving wire center is located in a Competitive County. If the End User channel termination is in a Competitive County, price flex rates and charges apply, as provided in Section 39.5.2. If the End User channel termination is in a Non-Competitive County, price cap rates and charges apply, as provided in Sections 7.3 and 20.5.

⁽¹⁾ Effective October 25, 2014, MegaLink Custom Services 10-year term plans are no longer available for new circuits. There is no change for existing circuits.

⁽²⁾ Effective on September 13, 2017, MegaLink Custom Services 5-year Payment Plans are no longer available, including for any otherwise available renewals or conversions. Circuits already subject to a MegaLink Custom Services 5-year Payment Plan, as of September 13, 2017, will continue to be provided under the then-current MegaLink Custom Services 5-year Payment Plan term for the remainder of that term.

⁽³⁾ Until February 1, 2018, End User channel terminations and their optional features that had not qualified for Phase II, Level 2 pricing flexibility prior to June 1, 2017, will be rated at the price cap rate regardless of the status of the county in which the applicable wire center is located.

⁽⁴⁾ Optional features for End User channel terminations includes all optional features in Section 7.3, except for the Loop Transfer Arrangement, and all optional features in Section 20.5.

Certain material previously appearing on this page now appears on 1st Revised Page 20-16.1.

20. MegaLink Custom Services (Cont'd)

20.4 Rate Regulations (Cont'd)

MegaLink Custom Services offer Portability for any existing term priced service provided each of the following conditions are met:

- (a) Service to be moved is either a 5 year⁽²⁾ or 10 year⁽¹⁾ Billing Period.
- (b) Customer must begin a new Billing Period (5 years or greater)⁽¹⁾⁽²⁾ for the service to be moved and the monthly revenue must be equal to or greater than that of the service in original location.
- (c) New service location is within the same state (i.e. Arkansas, Kansas, Missouri, Oklahoma or Texas) as the original service.
- (d) Facilities and equipment are available in the desired new location.

Charges to MegaLink Custom portability are set forth in 20.4.2(G).

20.4.1 Rate Categories

There are four basic rate categories which apply to MegaLink Custom Service:

- Channel Termination
- Interoffice Mileage
- Service to Service Through Connect Arrangements
- Optional Features, BSEs and Functions

⁽¹⁾ Effective October 25, 2014, MegaLink Custom Services 10-year term plans are no longer available for new circuits. There is no change for existing circuits.

⁽²⁾ Effective on September 13, 2017, MegaLink Custom Services 5-year Payment Plans are no longer available, including for any otherwise available renewals or conversions. Circuits already subject to a MegaLink Custom Services 5-year Payment Plan, as of September 13, 2017, will continue to be provided under the then-current MegaLink Custom Services 5-year Payment Plan term for the remainder of that term.

20. MegaLink Custom Services (Cont'd)

20.4 Rate Regulations (Cont'd)

20.4.1 Rate Categories (Cont'd)

(A) Channel Termination

Channel Termination provides for the communications path between a customer designated premises and the serving wire center for that premises or for the communications path within a building which connects a customer's facilities with a customer designated premises without routing through the serving wire center.

Two types of Channel Terminations are provided.

(1) Electrical Channel Termination

An Electrical Channel Termination provides for an electrical interface at the customer designated premises.

(2) Optical Channel Termination

An Optical Channel Termination provides for an optical interface at the customer designated premises.

(B) Interoffice Mileage

Interoffice Mileage provides for the transmission facilities between the serving wire centers associated with two customer designated premises, between a serving wire center and a Telephone Company Hub Central Office or, in the case of a Service Extension, between two Telephone Company Hub Central Offices.

There are two components of Interoffice Mileage.

(1) Interoffice Fixed

The Interoffice Fixed charge provides for the electronic equipment required to terminate an interoffice channel in the serving wire center(s) and Telephone Company Hub Central Office(s).

(2) Per Mile

The Per Mile charge provides for the electronic equipment and fiber optic cable necessary to provide the interoffice transport.

44.736 Mbps, ReliaNet DS3 Access Ports, etc.) in the same Telephone Company Hub Central Office.

20. MegaLink Custom Services (Cont'd)

20.4 Rate Regulations (Cont'd)

20.4.1 Rate Categories (Cont'd)

(C) Service to Service Through Connect Arrangements

The Service to Service Through Connect Arrangement rate category provides for an interconnection of two MegaLink Custom Services or services with equivalent interface transmission speeds (e.g., STN DTL at

(D) Optional Features, BSEs and Functions

The Optional Features, BSEs and Functions rate category provides for optional features, BSEs and functions which may be added to a MegaLink Custom Service to improve its quality or utility to meet specific communications requirements.

(1) Multiplexing

The Multiplexing rate category provides for an arrangement that converts a DS3 signal to 28 DS1 channels using digital time division multiplexing.

(2) STN Interconnection with SecureNet Equipped MegaLink Custom Service

The STN Interconnection with SecureNet equipped MegaLink Custom Service rate category provides automatic restoration capabilities which prevent service interruption in the event of a single facility break or a single electronics failure.

(E) Collocation Transport

Collocation Transport provides for the transmission facilities between collocation arrangements located in Telephone Company Central Offices.

There are two components of Collocation Transport.

(1) Inter/Intra Office Fixed

Inter/Intra office fixed rate element provides for the electronic equipment required to terminate a channel between two collocation arrangements located either in the same central office (intra) or in two separate central offices (inter).

(2) Inter Office Per Mile

The Per Mile charge provides for the electronic equipment and facilities necessary to provide the interoffice transport between two collocation arrangements.

20. MegaLink Custom Services (Cont'd)

20.4 Rate Regulations (Cont'd)

20.4.2 Nonrecurring Charges*

Nonrecurring charges are one-time charges that apply for specific work activity (i.e., installation of service or change to an existing service). The types of nonrecurring charges that apply for MegaLink Custom Service are:

- Installation of service
- Installation of optional features, BSEs and functions
- Installation of service to service through connect arrangements
- Service rearrangements
- Moves

(A) Nonrecurring Charges for the Installation of MegaLink Custom Service

Nonrecurring charges apply for each service installed and are applied per DS3 or DS3 equivalent, per customer designated premises on a first and additional basis.

The initial DS3 or DS3 equivalent incurs the first nonrecurring charge for each channel termination associated with the DS3 or DS3 equivalent. The remaining DS3s or DS3 equivalents incur the additional nonrecurring charge for each channel termination.

In order to receive the benefit associated with ordering multiple DS3 or DS3 equivalents, the following criteria must be met:

- Same Access Service Order
- Same Application for Service Date
- Same Due Date
- Identical Services
- Same Billing Account Number (BAN)
- Same Two Service End Points

* For Services ordered under MVP, refer to Section 38.3(E) (5).

0. MegaLink Custom Services (Cont'd)

20.4 Rate Regulations (Cont'd)

20.4.2 Nonrecurring Charges (Cont'd)

(B) Nonrecurring Charges for the Installation of Service Extensions

Service extensions to single or multiple hub locations ordered with the same due date as the associated DS3 or DS3 equivalent will not incur a nonrecurring charge. Service extensions to single or multiple hub locations ordered with a different due date than the associated DS3 or DS3 equivalent will incur a first and additional nonrecurring charge per DS3 or DS3 equivalent, per service extension.

In order to receive the benefit associated with ordering multiple DS3 or DS3 equivalents for one Service Extension, the following criteria must be met:

- Same Access Service Order
- Same Application for Service Date
- Same Due Date
- Identical Services
- Same Billing Account Number (BAN)
- Same Two Service End Points

20. MegaLink Custom Services (Cont'd)

20.4 Rate Regulations (Cont'd)

20.4.2 Nonrecurring Charges (Cont'd)

(C) Nonrecurring Charges for the Installation of Optional Features, BSEs and Functions

Nonrecurring charges apply for the installation of optional features, BSEs and functions available with MegaLink Custom Service. The charge applies whether the feature, BSE or function is installed coincident with the initial installation of service or at any time subsequent to the installation of the service, with the exception of C-Bit Parity Framing Format Option on MegaLink Custom Service, as described below.

(1) DS3 to DS1 Multiplexing

The nonrecurring charges for DS3 to DS1 multiplexers are applied on a per multiplexer basis.

(2) SecureNet

The nonrecurring charges for SecureNet are applied on a per premises, per DS3 basis.

(3) STN Interconnection with SecureNet Equipped MegaLink Custom Service

The nonrecurring charges for SecureNet Interconnection are applied on a per DS3 per interconnection basis. In addition, nonrecurring charges are applicable for two (2) Service to Service Through Connect Arrangements per DS3 per interconnection.

(4) C-Bit Parity Framing Format Option on MegaLink Custom Service

A nonrecurring charge is applied on a per DS3 first and additional basis when the option is added to existing MegaLink Custom Service.

(D) Nonrecurring Charges for the Installation of Service to Service Through Connect Arrangements

The nonrecurring charges for Service to Service through Connect Arrangements are applied per DS3 or DS3 equivalent basis.

20. MegaLink Custom Services (Cont'd)

20.4 Rate Regulations (Cont'd)

20.4.2 Nonrecurring Charges (Cont'd)

(E) Nonrecurring Charges for Service Rearrangements

Nonrecurring charges may apply for Service Rearrangements which are administrative changes to existing services which do not result in a change in the minimum period requirements or a change in the physical location of the point of termination at a customer designated premises.

The customer requesting administrative service rearrangements will be responsible for all billing associated with the changes requested.

A nonrecurring charge will apply per DS3 or DS3 equivalent on a first and additional basis for the following change or combination of changes requested by the customer on the same Access Order and will be charged as set forth in Section 20.5.8 (Administrative Charges).

- Change of Access Carrier Name Abbreviation (ACNA)
- Change of Billing Account Number (BAN)
- Change of Customer Circuit Identification (CKR)
- Change in customer of record

A change in the customer of record (i.e., existing access service is provided and billed to a different entity) is considered an administrative service rearrangement when the new customer assumes liability for all current and prior charges for the service(s) and has complied with the regulations and conditions as set forth in Section 2.2.1 (Assignment and Transfer of Facilities), preceding, and no physical relocation or rearrangement of the service is required.

20. MegaLink Custom Services (Cont'd)

20.4 Rate Regulations (Cont'd)

20.4.2 Nonrecurring Charges (Cont'd)

(E) Nonrecurring Charges for Service Rearrangements
(Cont'd)

When a change of customer name and change in billing data (name, address, contact name, or telephone number) are requested in association with a change in the customer of record, the Access Order Charge will apply as set forth in Section 5.3.1 (Access Order Charges) preceding.

Certain administrative changes will be made without charge(s) to the customer. These administrative changes are as follows:

- Change of customer name, (i.e., the customer of record does not change but rather the customer of record changes its name--e.g., ABC Communications to All Business Concepts Communications).
- Change of customer's or customer's end user premises address when the change of address is not a result of a physical relocation of the service.
- Change in billing data (name, address, contact name, or telephone number).
- Change of agency authorization.
- Change of customer test line number.
- Change of customer's or customer's end user contact name or contact telephone number.
- Change of jurisdiction.

(F) Nonrecurring Charges for Moves

Nonrecurring charges apply for the work activity necessary to provide a change in the physical location of a customer's premises or the point of termination at a customer's premises. The nonrecurring charges for move activities are further explained in Section 20.4.12 (Moves).

(G) Nonrecurring Charges for Portability

Nonrecurring charges apply when a customer elects to relocate a MegaLink Custom Service under the Portability provision, as discussed in 20.4. The nonrecurring charge will be assessed on a per DS3 relocated basis. The specific charge will be the nonrecurring charge associated with the particular rate element which is being relocated, as specified in 20.5 (Rates and Charges).

20. MegaLink Custom Services (Cont'd)

20.4 Rate Regulations (Cont'd)

20.4.3 Monthly Recurring Rates

Monthly recurring rates are charges that apply each month or fraction thereof that MegaLink Custom Service is provided. For billing purposes, each month is considered to have 30 days.

Monthly Extension Rates

Monthly extension rates are charges that the customer may elect to be converted to at the end of a term plan, until a new term is selected or service is disconnected. Monthly extension rates are only available once the term plan has expired.

Monthly recurring rates apply to the following rate categories.

(A) Monthly Recurring Rates For Channel Termination

The monthly recurring rates for Channel Terminations are based on the Channel Termination Volume Options and billing periods selected by the customer.

The Channel Termination Volume Options designate the number of DS3s or DS3 equivalents associated with the service. The volume options include quantities of 1, 3, 6 and 12 DS3s or DS3 equivalents.

The Channel Termination charge also depends on the channel termination interface selected by the customer. A customer may select an electrical or optical interface.

Optical interfaces are provided on fiber facilities. When selecting an optical interface, the customer restates the bit rate (i.e., transmission speed) as an appropriate DS3 equivalent in order to determine the applicable rates.

20. MegaLink Custom Services (Cont'd)

20.4 Rate Regulations (Cont'd)

20.4.3 Monthly Recurring Rates (Cont'd)

(A) Monthly Recurring Rates For Channel Termination
(Cont'd)

The following chart illustrates typical transmission speeds available for optical interfaces and the DS3 equivalent for each speed.

<u>Transmission Speed</u>	<u>Equivalent DS3s</u>
45 Mbps	1
150 Mbps	3
565 Mbps	12

Equipment utilized by the customer to terminate an optical signal provided by the Telephone Company must be compatible with the equipment the Telephone Company utilizes to transmit the optical signal.

One Channel Termination charge applies per customer designated premises at which the service is terminated. This charge applies even if the customer designated premises and the serving wire center are located in the same Telephone Company building. Channel Termination Volume Options for each Channel Termination for a customer designated premises to customer designated premises service must be the same.

20.4 Rate Regulations (Cont'd)

20.4.3 Monthly Recurring Rates (Cont'd)

(A) Monthly Recurring Rates For Channel Termination
(Cont'd)

To develop a Channel Termination rate for a quantity of DS3s or DS3 equivalents not contained in a Channel Termination Volume Option, the customer must specify the appropriate Volume Options which result in the requested number of DS3s or DS3 equivalents.

Example: A customer who wants a 5 year billing period for 7 DS3s from a premises to a Telephone Company Hub Central Office may choose the following Channel Termination Rates:

A 5 year Electrical Channel Termination Volume Option of 6 DS3s

plus

A 5 year Electrical Channel Termination Volume Option of 1 DS3

Electrical interface and optical interface Channel Termination Volume Options may not be combined on one request for service at the same customer designated premises.

(B) Monthly Recurring Rates For Interoffice Mileage

The Interoffice Mileage charges are based on the number of interoffice miles, volume option and billing period selected.

When interoffice mileage is required, the following charges will apply.

(1) Interoffice Fixed

The Interoffice Fixed charge is based on the billing period selected by the customer and is applied on a per DS3 or DS3 equivalent basis.

The rate is developed by multiplying the number of DS3s or DS3 equivalents by the appropriate fixed charge based on the billing period specified by the customer.

(2) Per Mile

A Per Mile rate is based on the Channel Termination Volume Option and billing period selected by the customer and is applied on a per airline mile basis.

The Volume Option utilized to develop the Per Mile rate must be the same as the Channel Termination Volume Option specified by the customer.

To calculate the appropriate rate, multiply the number of miles, as calculated in Section 20.4.7 (Determining the Interoffice Mileage), by the appropriate Per Mile rate, for the billing period selected.

20. MegaLink Custom Services (Cont'd)

20.4 Rate Regulations (Cont'd)

20.4.3 Monthly Recurring Rates (Cont'd)

(C) Monthly Recurring Rates For Optional Features, BSEs and Functions

(1) DS3 to DS1 Multiplexing

The recurring rates for DS3 to DS1 multiplexing arrangements are applied on a per multiplexer basis and are based on the billing period selected by the customer.

(2) SecureNet

The recurring rates for SecureNet are applied on a per premises, per DS3 basis and are based on the billing period selected by the customer.

(3) Service Extensions

The recurring rates applicable for a Service Extension utilize the Interoffice Fixed and Per Mile charge applicable for MegaLink Custom Service.

The Interoffice Fixed rate is based on the billing period selected by the customer and is applied on a per DS3 or DS3 equivalent basis. The Interoffice Fixed rate for the Service Extension is applicable in addition to an Interoffice Fixed charge which may be applicable for the MegaLink Custom Service.

The Per Mile rate for a Service Extension is based on the billing period and Volume Option specified by the customer and is applicable for the appropriate number of miles from the original Telephone Company Hub Central Office to the new Telephone Company Hub Central Office.

(4) STN Interconnection with SecureNet Equipped MegaLink Custom Service

The recurring rates for this interconnection are applied per DS3 per interconnection and are based on the billing period selected by the customer.

20. MegaLink Custom Services (Cont'd)

20.4 Rate Regulations (Cont'd)

20.4.4 Billing Period

- (A) The billing period establishes the amount of time that rates for a service are stabilized by the Telephone Company.

The following billing periods are available for MegaLink Custom Services and associated optional features, BSEs and functions:

Monthly (Temp-DS3)
Month to Month*
Monthly Extension:

1 year, 3 year, 5 year⁽²⁾ and 10 year⁽¹⁾

One month prior to the expiration of the billing period, with the exception of Temp-DS3, the customer must select one of the following options:

- (1) Renew the service for a specified period of time as provided in this tariff under the regulations, nonvintage rates in effect at the time of expiration of the existing service.
- (2) Elect to be converted to monthly extension rates.
- (3) Elect to disconnect the service upon expiration of the billing period.

If a customer selects neither (1) nor (3) preceding, the current regulations, non-vintage rates and charges for the Month to Month rate option will be applied upon expiration of the billing period.*

If the customer does not choose one of the preceding options prior to the expiration date of the commitment period, monthly extension rates will be applied upon expiration of the commitment period.

Option (1) as described preceding is available to customers if the term plans remain in effect and are not grandfathered. If the term plans are grandfathered and the service expires, absent customer notification, the customers expired service will be converted to monthly extension rates upon expiration.

The customer must provide the Telephone Company with a written notice of intent to extend the DS3 billing period no later than one month prior to the expiration of the service period.

The customer's existing service will not be subject to the 1 year minimum service period after reverting to the monthly extension rate option.

Nonrecurring charges are not applicable for services renewed, as long as the same number of DS3s are renewed. Any change in the number of DS3s will incur the appropriate nonrecurring charges.

For Temp-DS3 the minimum billing period is one (1) month and the maximum billing period is eleven (11) months.

* This option will no longer be available for new circuits provisioned on or after, November 21, 2003. There will be no change to existing circuits.

⁽¹⁾ Effective October 25, 2014, MegaLink Custom Services 10-year term plans are no longer available for new circuits. There is no change for existing circuits.

⁽²⁾ Effective on September 13, 2017, MegaLink Custom Services 5-year Payment Plans are no longer available, including for any otherwise available renewals or conversions. Circuits already subject to a MegaLink Custom Services 5-year Payment Plan, as of September 13, 2017, will continue to be provided under the then-current MegaLink Custom Services 5-year Payment Plan term for the remainder of that term.

20. MegaLink Custom Services (Cont'd)

20.4 Rate Regulations (Cont'd)

20.4.4 Billing Period (Cont'd)

(B) Provided the end points remain the same, a customer may request to convert from MegaLink Custom Service Vintage rates and charges to MegaLink Custom Service rates and charges. All terms and conditions will apply as set forth in 20.1 through 20.5.8.

With the exception of the Access Order Charge as set forth in 5.3.1, no nonrecurring charges will apply.

A customer must establish a minimum of a 5-year billing period if 5 or more years remain on the existing Vintage billing period. If the existing Vintage billing period is less than 5 years but more than 1 year, a minimum of a 3-year billing period must be established. For an existing Vintage billing period of 1 year or less, a customer must establish a Month-to-Month billing period for a minimum of 1 year.

20.4.5 Minimum Service Periods

Minimum service periods establish the minimum period for which a MegaLink Custom Service or an optional feature, BSE and function will be provided.

The minimum service periods are as follows:

MegaLink Custom Service	1 year
Temp-DS3	1 month
Service Extension	1 year
SecureNet Options	1 year
Central Office Multiplexing	1 month*
Central Office Multiplexing	1 year
Interoffice Mileage	
-(Fixed and Per Mile)	1 year

When a service is discontinued prior to the expiration of the minimum service period, the applicable charge will be the total monthly charges for the remainder of the minimum service period plus termination charges for the remainder of the billing period as described in Section 20.4.6.

Services which are terminated after the minimum service period and prior to the expiration of the billing period are subject to termination charges as described in Section 20.4.6 (Termination Charges).

If a customer requests a change from a MegaLink Custom Service Vintage billing period to a MegaLink Custom Service billing period, a new minimum service period must be established.

* This option will no longer be available for new circuits provisioned on or after, November 21, 2003. There will be no change to existing circuits.

20. MegaLink Custom Services (Cont'd)

20.4 Rate Regulations (Cont'd)

20.4.6 Termination Charges

In the event service is terminated prior to the expiration of the minimum service period, charges, as specified in Section 20.4.5 (Minimum Service Periods), will apply. Termination charges do not apply to Temp-DS3 service. In the event service is terminated after the minimum service period and prior to the end of the billing period, a termination charge utilizing the following termination percentage will apply:

<u>Billing Period</u>	<u>Termination Percentage</u>
1, 3, 5 or 10 year ^{(1) (2)}	20%

The termination charge is based on the volume option selected by the customer.

The termination charge is calculated as follows:

monthly rate x $\frac{\text{months remaining}}{\text{in billing period}}$ x termination percentage

Example: A customer with a \$5,000 monthly rate terminates service with 10 months remaining in a 3 year billing period. The termination charge would be calculated as follows:

$$\$5,000 \times 10 \times .20 = \$10,000$$

The termination charge would be: \$10,000

If Special Construction applied for the service being terminated, an associated Termination Charge, as set forth in F.C.C. No. 69, Section 2.6.4 (Types of Liabilities and Charges), may apply.

When a MegaLink Custom service, which is billed under the Shared Use provision is terminated, the termination liability will be based on the full charges as listed in Section 20.5 herein, as opposed to the Shared Use billed amount.

⁽¹⁾ Effective October 25, 2014, MegaLink Custom Services 10 year term plans are no longer available for new circuits. There is no change for existing circuits.

⁽²⁾ Effective on September 13, 2017, MegaLink Custom Services 5-year Payment Plans are no longer available, including for any otherwise available renewals or conversions. Circuits already subject to a MegaLink Custom Services 5-year Payment Plan, as of September 13, 2017, will continue to be provided under the then-current MegaLink Custom Services 5-year Payment Plan term for the remainder of that term.

20. MegaLink Custom Services (Cont'd)

20.4 Rate Regulations (Cont'd)

20.4.6 Termination Charges (Cont'd)

When an existing DS3 circuit is reterminated in a Network Reconfiguration Port, termination charges as set forth in 20.4.5 (Minimum Service Periods), 20.4.6 (Termination Charges) and 20.4.12(B) (Moving Customer Premises), will only apply to the Optional Features, BSEs and Functions associated with the reterminated DS3 circuit. Termination charges will not apply to Channel Terminations and Interoffice Mileage associated with the reterminated DS3 circuit when the DS3 end points involved do not change.

Under the following conditions, a termination charge will not apply:

- At the time the customer modifies service as set forth in Section 20.4.13 (Modification of Service).
- At the time the customer relocates a DS3 to DS1 Multiplexer, as set forth in Section 20.4.14 (Relocation of a DS3 to DS1 Multiplexer).
- At the time the customer replaces a MegaLink Custom Service with a STN, DSRS or ReliaNet Service subject to the following criteria:
 - (1) Both MegaLink Custom Service end points must be on the STN, DSRS or ReliaNet;
 - (2) the Minimum Period for STN, DSRS or ReliaNet must be greater than or equal to the remaining MegaLink Custom Service Billing Period; and,
 - (3) the total Minimum Period revenue for the STN, DSRS or ReliaNet must be greater than or equal to the remaining Billing Period revenue for the MegaLink Custom Service.

20. MegaLink Custom Services (Cont'd)

20.4 Rate Regulations (Cont'd)

20.4.7 Determining Interoffice Mileage

The mileage to be used to determine the monthly rate for the Interoffice Per Mile rate is calculated on the airline distance between the two serving wire centers for a service with two channel terminations, between the serving wire center and the Telephone Company Hub Central Office or, in the case of a Service Extension, between two Telephone Company Hub Central Offices. The serving wire center associated with a customer designated premises is the serving wire center from which the customer designated premises would normally obtain dial tone.

To calculate the appropriate mileage, use the V&H coordinate method, as set forth in the National Exchange Carrier Association, Inc. Tariff F.C.C. No. 4. If the calculation results in a fraction of a mile, round up to the next whole mile.

20.4.8 Ordering Options and Conditions

MegaLink Custom Services are ordered under the Access Order provisions set forth in Section 5 (Ordering for Access Service) preceding. Also included in Section 5 are other charges which may be associated with ordering MegaLink Custom Service (e.g., Service Date Change Charges, Cancellation Charges, etc.)

Ordering, rating and billing procedures as set forth in Section 2.6 (Jointly Provided Access Services), preceding, will apply for MegaLink Custom Service where more than one exchange telephone company is involved (i.e., jointly provided service).

Temp-DS3 customers must submit connect and disconnect orders at the time of initial service order. Temp-DS3 service may be extended once for a maximum of 30 days provided the customer notifies the Telephone Company at least 15 days prior to the established disconnection date. Extensions beyond this period will not be permitted.

20.4.9 Special Access Surcharge

Regulations for the Special Access Surcharge may apply for all jurisdictionally interstate special access facilities as set forth in Section 7.2.5 (Surcharge for Special Access Service) preceding.

20.4.10 Message Station Equipment Recovery Charge

Regulations for the Message Station Equipment Recovery Charge may apply as set forth in Section 7.2.17 (Message Station Equipment Recovery Charge) preceding.

20. MegaLink Custom Services (Cont'd)

20.4 Rate Regulations (Cont'd)

20.4.11 Shared Use

Shared use is the provision of Switched Access and MegaLink Custom Services over the same transmission path through the use of a common interface. Shared use is only available with MegaLink Custom Services provided from a customer designated premises to a Telephone Company Hub Central Office including Service Extensions provided between two Telephone Company Hub Central Offices.

Regulations for shared use facilities are set forth in 6.8.12 (Shared Use), 7.2 (Rate Regulations), 19.3 (Rate Regulations), 20.4 (Rate Regulations), 23.3 (Rate Regulations), 29.3 (Rate Regulations) and 30.3 (Rate Regulations). Ordering provisions for shared use facilities are set forth in 5.2.5 (Shared Use).

Existing MegaLink Custom facilities can be converted to shared use facilities by activating a portion of available capacity for Switched Access. Services provided over a shared use facilities are ordered, provided and rated either as Switched Access (i.e., Entrance Facility, Direct-Trunked Transport, Tandem-Switched Transport and Multiplexing) or as MegaLink Custom (i.e., Channel Termination, Interoffice Mileage and Multiplexer) as set forth following:

- (A) On shared use facilities, the customer for the Switched Access Service may be different from the customer for the MegaLink Custom Service. When the Switched Access Customer is not the same as the MegaLink Custom customer, all MegaLink Custom charges and Switched Transport charges (including Switched Transport features charges) will be billed to the customer who initially ordered the facility. All other Switched Access charges will be separately billed to the customer who ordered the Switched Access Service.
- (B) When an existing MegaLink Custom facility is converted to a shared use facility by using an available portion of the capacity for Switched Access Service, the applicable nonrecurring charges (including the Access Order Charge) will be the nonrecurring charges associated with the Switched Access service being ordered.

20. MegaLink Custom Services (Cont'd)

20.4 Rate Regulations (Cont'd)

20.4.11 Shared Use (Cont'd)

- (C) The customer must place an order for each individual Switched Access Service or MegaLink Custom Service utilizing the shared use facility and must also specify the channel assignment for each service.
- (D) All channels within a shared use facility will be rated and billed as set forth in (1) through (5) following:
 - (1) When a DS1 facility is ordered and provisioned as Switched Access, all channels, including spares, will be rated and billed as Switched Access until such time as the DS1 facility becomes shared use.
 - (2) When a DS1 facility is ordered and provisioned as a Special Access High Capacity Service, all channels, including spares, will be rated and billed as Special Access until such time as the DS1 facility becomes shared use.
 - (3) Once a DS1 facility, ordered as either Switched or Special Access, becomes shared use, all spare channels on the DS1 facility will be rated and billed as Special Access.
 - (4) On a DS3 shared use facility, ordered either as Switched Access or Megalink Custom Service, the Switched Access channels on the DS3 facility must equal the cumulative value of the channels (both active and spare) counted as Switched Access on each DS1 facility.

For example, a Switched Access DS1 facility, which contains 20 active and 4 spare channels, is activated on a shared use DS3 facility. The DS1 facility is considered pure switched access and the shared use DS3 facility is prorated by 24 switched channels, i.e., 24/672.

Subsequently, 6 of the switched channels from the Switched Access DS1 facility are disconnected and become spare. Since the DS1 facility is still considered pure switched, the shared use DS3 facility will continue to be prorated by 24 switched channels, i.e., 24/672.

If, at a later date, the Switched Access DS1 facility becomes shared use by the addition of 6 Special Access channels, the DS1 spare channels will then default to Special Access. The DS3 facility will be prorated by 14/672 to reflect the new switched channel value on the shared use DS1, i.e., 14 active switched, 6 active special and 4 spare.

If multiplexing were associated with the shared use facility, the monthly recurring rate for the multiplexer would be prorated in the same manner as the Entrance Facility and Channel Termination.

- (5) Channels being used in conjunction with CCS/SS7 Interconnection Service are included in the channel counts for Switched Access.
- (E) Customers requesting Service Facility Moves (SFM) of shared use facilities will be assessed nonrecurring charges as specified in 6.8.10 (Moves), 7.2.7 (Moves), 19.3.7 (Moves), 20.4.12 (Moves) and 23.3.6 (Moves) with the nonrecurring charges being prorated as set forth in (D) (1) through (D) (5) preceding.

20. MegaLink Custom Services (Cont'd)

20.4 Rate Regulations (Cont'd)

20.4.12 Moves

A move involves a change in the physical location of one of the following:

- The service facility
- The Point of Termination at the customer's premises;
- the customer's premises.

The charges are dependent upon the type of move requested by the customer.

(A) Service Facility Move (SFM)

An SFM is a customer-initiated move of one end of a Telephone Company central office distribution link (e.g., jumper cable, DSX patch cable, etc.) from one facility to another existing facility (of the same or higher transmission speed). All activity associated with the SFM must occur within a single Telephone Company location (central office).

In order to be considered an SFM, all associated order activity (disconnects and new connects) must occur simultaneously and the facility to which service is being moved must be existing and have sufficient capacity to accept the moved service.

An SFM may result in the change of one end point (i.e., customer premises location) of the circuit involved provided the following conditions are met:

- (1) The change of customer premises can only occur on the end of the circuit which has the CFA.
- (2) The customer premises locations involved in the change belongs to the same customer.

- or -

The customer premises locations involved in the change belongs to two different customers but the customer requesting the SFM has previously coordinated the activity such that all activity (disconnects and new connects) will occur simultaneously. If this coordination has not been accomplished beforehand, then the Telephone Company will proceed with the disconnect/new connect orders as non-related and new installation charges will apply for services being relocated.

20. MegaLink Custom Services (Cont'd)

20.4 Rate Regulations (Cont'd)

20.4.12 Moves (Cont'd)

(A) Service Facility Move (SFM) (Cont'd)

On facility moves involving multiplexed (subtending) channels, SFMs shall be charged only for the higher level facility provided the entire facility (the full complement of subtending channels) is being moved concurrent to that particular SFM request. If the subtending channels are requested to be moved one at a time, the SFM will be charged on a per each channel moved basis.

Example 1

An SFM is requested to move 20 DS1s, with subtending VG channels, to a DS3 facility (where the DS3 end of the channel is moving to a new customer premises location). The resulting SFM charge will be 20 DS1 to DS3 SFM charges with no SFM charges for the subtending VG channels.

Example 2

An SFM is requested to move a DS3, with subtending DS1 channels, to another DS3 facility (where there is no change in the customer premises location on the DS3 facility end of the circuit). The resulting SFM charge will be a DS3 to DS3 SFM with no SFM charges for the subtending DS1 channels.

Example 3

An SFM is requested to move 6 DS1s, with subtending VG channels, previously riding one DS3 facility to another DS3 facility. The resulting SFM charge would be (6) DS1 to DS3 SFMs with no SFM charges for the subtending VG channels.

Under MegaLink Custom Service, SFMs may be performed at the following service levels:

- DS3 to DS3 (or equivalent 45 Mbps service)

The charges for an SFM for the services shown above are detailed in 20.5.7(I) (SFMs) following. There will be no change in minimum period requirements.

20. MegaLink Custom Services (Cont'd)

20.4 Rate Regulations (Cont'd)

20.4.12 Moves (Cont'd)

(B) Moves of the Point of Termination Within the Same Customer Premises

A move of a Point of Termination of an existing service to a new location within the same customer premises, may be provided, at the customer's request, on a time sensitive charge basis.

The labor rates which apply are as set forth in Section 13.4.2(C) (Testing and Maintenance With Other Telephone Companies or Other Labor), preceding, of this tariff for Additional Labor. No change in billing period is required.

(C) Moving Customer Premises

A move of existing service may be provided at the customer's request. The customer will be billed 5% of the termination charge as set forth in 20.4.6 (Termination Charges), with the exception as follows. Following the payment of applicable termination charges, customer will be responsible for any nonrecurring charges associated with the reconnection of the service (e.g., Channel Termination Installation Charge).

If the move of the customer's premises is as a result of an SFM (Service Facility Move) according to Sect. 20.4.12(A), and the facility to the new premises is existing, then termination charges will not apply. No nonrecurring charges will apply for that end of the channel or circuit except the applicable SFM charge.

One end of a MegaLink Custom service (e.g., the customer premises) may be moved without termination liability provided the following circumstances exist:

- 1) Customer maintains the same level and commitment of service (i.e., quantity of DS3 channels and billing period length).
- 2) All equipment and transport facilities exist at the new location.

Charges for this one-ended move shall be on a time sensitive charge basis. The labor rates which apply are set forth in Section 13.4.2(C) (Testing and Maintenance With Other Telephone Companies or Other Labor).

The diagrams following illustrate typical service arrangements before and after an SFM has occurred.

20. MegaLink Custom Services (Cont'd)

20.4 Rate Regulations (Cont'd)

20.4.12 Moves (Cont'd)

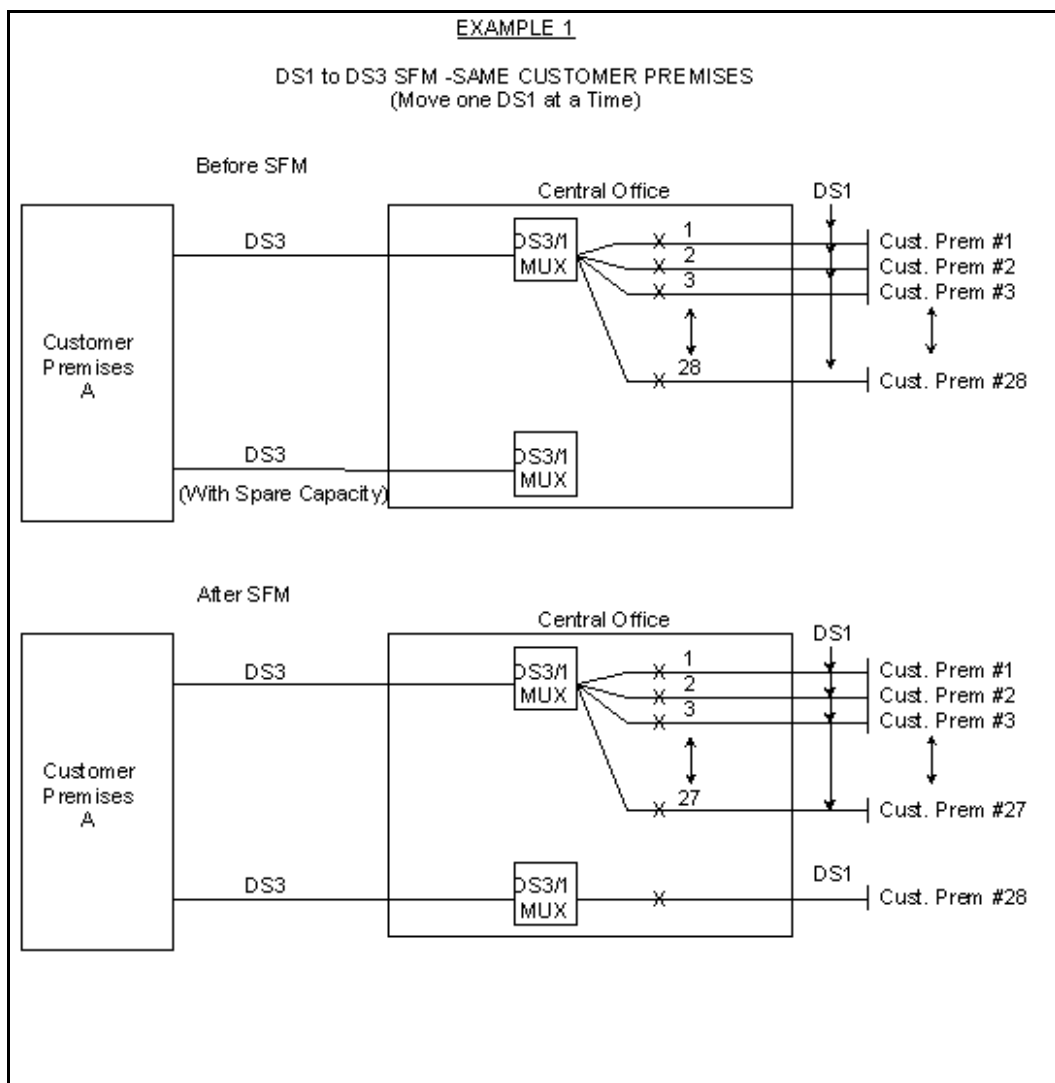

20. MegaLink Custom Services (Cont'd)

20.4 Rate Regulations (Cont'd)

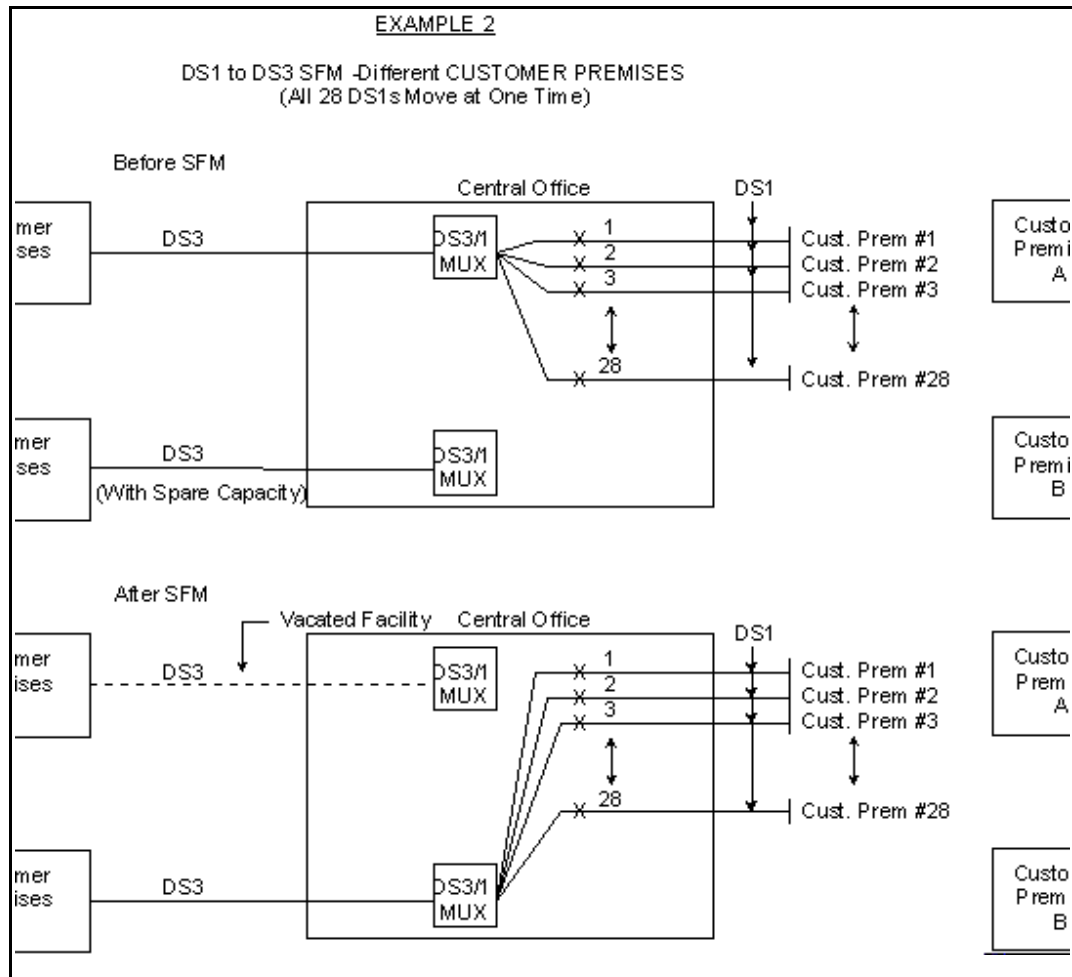

20. MegaLink Custom Services (Cont'd)

20.4 Rate Regulations (Cont'd)

20.4.12 Moves (Cont'd)

EXAMPLE 3

DS3 to DS3 SFM -Different CUSTOMER PREMISES

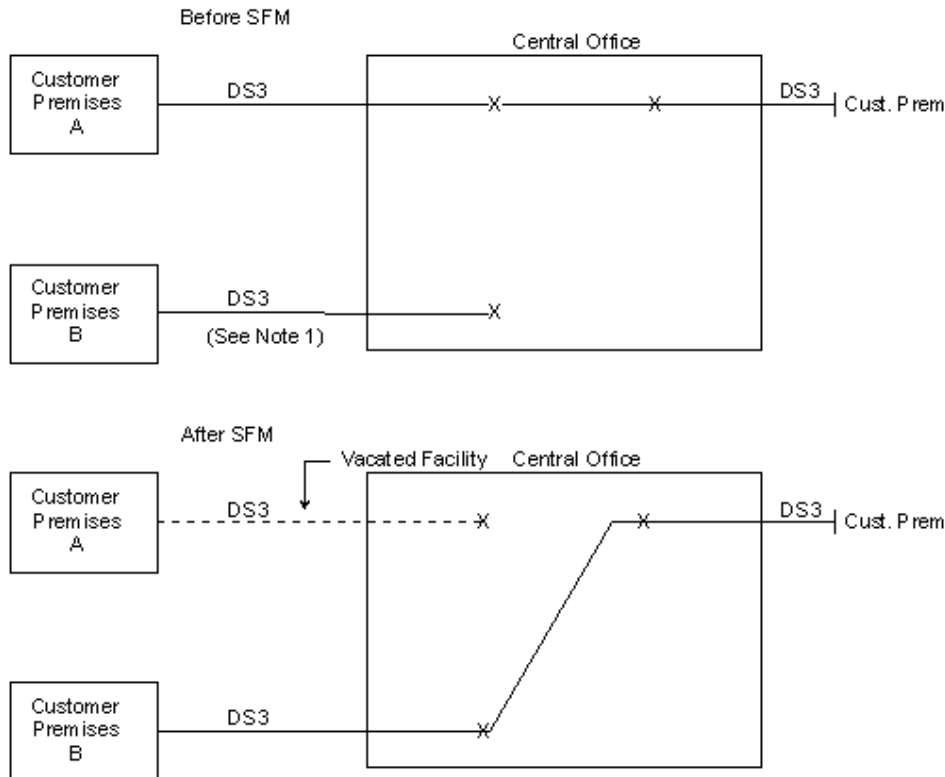

Note 1: This facility may exist as a result of an order for MegaLink Custom (DS3) service concurrent with the SFM request or, in the case of virtual collocation, as a cross-connect arrangement requested by the interconnector.

20. MegaLink Custom Services (Cont'd)

20.4 Rate Regulations (Cont'd)

20.4.13 Modification of Service

The customer may request to modify service (i.e., establish a new billing period or add rate elements to existing service) provided all the following conditions are met:

- a new billing period is established which includes a new minimum service period
- the expiration of the new billing period must extend to or beyond the expiration of the existing billing period
- the total revenue, based on recurring rates, over the revised billing period must be equal to or greater than the remaining revenue from the existing billing period
- the service end points must remain the same

The non-vintage rates and charges (as listed in Section 20.5) in effect at the time service is modified are the rates and charges which will be billed to the customer during the new billing period. No additional administrative charges shall apply to these modifications except the Access Order Charge as set forth in 5.3.1.

20. MegaLink Custom Services (Cont'd)

20.4 Rate Regulations (Cont'd)

20.4.14 Relocation of a DS3 to DS1 Multiplexer

A customer may request to relocate a DS3 to DS1 Multiplexer. The customer will be charged the nonrecurring charge as specified in 20.5.7(B) (DS3 to DS1 Multiplexing), following, for the installation of the relocated multiplexer. A termination charge, as described in 20.4.6 (Termination Charges), preceding, will not apply for the DS3 to DS1 Multiplexer at the time it is relocated.

20.4.15 Service Extension

The Volume Option for a Service Extension must be less than or equal to the Channel Termination Volume Option specified by the customer for the MegaLink Custom Service being extended.

MegaLink Custom Service with Serving Wire Center and Facility Redundancy can be extended with a Service Extension. However, the Service Extension cannot be equipped with a SecureNet option.

MegaLink Custom Service with Hub Redundancy cannot be extended with a Service Extension. Likewise, an existing MegaLink Custom Service with a Service Extension cannot be equipped with a Hub Redundancy option.

20.4.16 Facility Hubs

The Telephone Company will commence billing the monthly rate for the facility to the hub on the date specified by the customer on the Access Order. Individual services utilizing these facilities may be installed coincident with the installation of the facility to the hub or may be ordered and/or installed at a later date, at the option of the customer. The customer will be billed the appropriate MegaLink Custom Channel Termination, Interoffice Mileage (when applicable) and the Multiplexer rates at the time the facility is installed. Individual service rates (by service type) will apply for a Channel Termination and additional Channel Mileage (as required) for each channelized service.

When cascading multiplexing is performed, whether in the same or a different hub, a charge for the additional multiplexing unit also applies. When cascading multiplexing is performed at different hubbing locations, Interoffice Mileage charges also apply between the hubs.

20. MegaLink Custom Services (Cont'd)

20.4 Rate Regulations (Cont'd)

20.4.17 Connecting Facility Assignment Credits

Connecting Facility Assignment (CFA) Credit is an option available to customers of MegaLink Custom Services who allow the Telephone Company use of their channel terminations for the provision of Special Access High Capacity (DS1) channel terminations to other Telephone Company customers. With CFA Credits, the Telephone Company will provide a credit to the customer of the MegaLink Custom Service for the use of their DS3 channel termination and associated DS3 to DS1 multiplexer. The Telephone Company will bill the customer of the DS1 service for the DS1 Channel Termination so provided.

The following terms and conditions apply to all CFA Credit Arrangements.

- (A) The Access Customer Name Abbreviation (ACNA) for the Special Access High Capacity Customer must be different than the ACNA for the customer of the MegaLink Custom Service.
- (B) Requests to establish or discontinue a CFA Credit will be accepted only from the customer of the MegaLink Custom Service.
- (C) When requesting a CFA Credit, the DS3 customer must provide the Telephone Company with information sufficient to correctly establish billing for a DS1 channel termination. This includes the CFA of the DS3, the DS1 customer's name, and the channel assigned to that customer. The Telephone Company will work cooperatively with the DS3 customer to identify the DS1 customer(s). However, if the DS3 customer cannot or will not provide the required information, CFA Credits will not be established.

20. MegaLink Custom Services (Cont'd)

20.4 Rate Regulations (Cont'd)

20.4.17 Connecting Facility Assignment Credits (Cont'd)

- (D) The Telephone Company and the DS3 customer must also agree to work cooperatively to maintain accurate customer records of any CFA Credit arrangements. The customer records which must be jointly maintained are:

-connecting facility assignments by DS1 customer and
-additions, moves or deletions of DS1 customers onto
or off of the DS3 channel termination.

If the Telephone Company and the DS3 customer cannot work cooperatively to maintain these customer records, additional CFA Credits will not be established.

- (E) CFA Credits can be established on Special Access DS3s for Special Access DS1s only. In addition, if channels become vacant subsequent to the establishment of a CFA Credit (e.g., the DS1 customer disconnects service), the CFA Credit will be eliminated.
- (F) In any month, the total CFA credits for any MegaLink Custom channel termination shall not exceed 100 percent of the combined monthly charges for the MegaLink Custom channel termination and its associated DS3 to DS1 multiplexer.
- (G) After the DS3 customer has requested a CFA Credit on an existing MegaLink Custom Service, and the Telephone Company and the DS3 customer have reached agreement that sufficient information has been identified to accurately initiate or modify the CFA Credit arrangement, within five business days of the date of reaching such agreement, the Telephone Company will send the DS1 customer via U.S. Mail a 30-day advance written notification before allowing the CFA Credit arrangement to become effective.

20. MegaLink Custom Services (Cont'd)

20.4 Rate Regulations (Cont'd)

20.4.17 Connecting Facility Assignment Credits (Cont'd)

- (H) The Telephone Company will only remove a DS1 customer from the CFA Credit arrangement at the request of the DS3 customer or because the DS1 customer has disconnected service or moved service to a different transport facility. The DS3 customer must give the Telephone Company 14 days advance written notification of any request to remove a DS1 customer from the CFA Credit arrangement.
- (I) In the event a billing dispute is initiated by a DS1 customer, the Telephone Company will negotiate with the DS1 customer as set forth in 2.5 (Billing Regulations).
- (J) The Telephone Company will accept requests to disconnect the DS3 service only from the customer for the MegaLink Custom Service. So that DS1 customers using the DS3 channel termination will have the opportunity of continuing service without disruption, the DS3 customer is responsible for notifying all DS1 customers of the disconnection.
- (K) The credit to be applied for each DS1 channel termination using the DS3 channel termination is set forth in 20.5.5 (MegaLink Custom Service). Charges for DS1 service are set forth in 7.3.10 (High Capacity Service).

20.4.18 Temp-DS3 Service

Temp DS3 service is provided for customers who require a MegaLink Custom Service for a short duration of time (less than 12 months), such as a trade show or convention.

Temp-DS3 is provided where facilities and equipment are available and is subject to billing in full month increments. These rate elements will all carry 30 day minimum periods and a maximum period of 11 months. No other rate elements, except as listed herein, are available for use with Temp-DS3 service. Temp-DS3 is only available with Volume Option 1.