

21. Optical Carrier Network (OCN) Point-to-Point Service

21.1 General Description

OCN Point-to-Point service will be designed to provide the customer with a custom point to point linear network. The Optical Point-to-Point service will offer a highly reliable transport service that is designed to connect customer locations and SBC wire centers in a linear (point to point) configuration. Large volumes of information can be transported between two locations in a dedicated, high-bandwidth optical path. Specifically, the OCN Point-to-Point services can handle voice, data, video, imaging, Internet traffic and other advanced broadband applications.

Rates and charges for Optical Carrier Network (OCN) Point-to-Point Service are set forth in Section 21.3, with the exception (D) of the services provided by the Telephone Company in the Metropolitan Statistical Areas (MSAs) in which the Telephone Company has received Phase II pricing flexibility pursuant to Subpart H of Part 69 of the Commission's Rules. The rates and charges for the Optical Carrier Network (OCN) Point-to-Point Service in the MSAs that have received Phase II pricing flexibility are set forth in Section 22.

(A) OCN Point-to-Point channels provide high speed synchronous optical fiber-based full duplex data transmission capabilities between two points. These services provide optical data transmission with the following characteristics:

- (1) OC-3/OC-3c provides channels operating at the terminating bit rate of 155.52 Mbps;
- (2) OC-12/OC-12c provides channels operating at the terminating bit rate of 622.08 Mbps;
- (3) OC-48/OC-48c provides channels operating at the terminating bit rate of 2488.32 Mbps;
- (4) OC-192/OC-192c provides channels operating at the terminating bit rate of 9953.28 Mbps;

(B) OC-3, OC-12, OC-48 and OC-192 channels may be used to connect:

- (1) a customer designated premises to another customer designated premises, without the add/drop multiplexing capability.
- (2) a customer designated premises to a Telephone Company location where add/drop multiplexing and add/drop functions are performed.
- (3) a Dedicated SONET Ring Service node in a Telephone Company location to a customer designated premises or a Collocator's physical or virtual collocation--this serving arrangement is referred to as (SMOA) SONET Mapped Optical Arrangement or to a Telephone Company location where add/drop multiplexing and add/drop functions are performed and this serving arrangement is referred to as (SMUX) SMOA with a MUX.
- (4) two Dedicated SONET Facility nodes in the same or different Telephone Company location--this serving arrangement is referred to as (DIN) Dedicated Interconnection Network.

Optical Transmission paths for OC-3/OC-3c, OC-12/OC-12c, OC-48/OC-48c and OC-192/OC-192c differentiated by bit rate and the quality of transmission is as delineated by the Optical Interface definitions in the appropriate technical reference publication(s) for the service ordered.

OC-3, OC-12, and OC-48 may be connected by (1) using the appropriate OC-3, OC-12 or OC-48 add/drop multiplexer (mux) along with the add/drop function to a DS1 and/or DS3 at suitably equipped wire centers, or (2), by using the full bandwidth premises to premises.

Where appropriate facilities are not immediately available, negotiated intervals or special construction charges may apply. The customer is responsible via the ordering process to identify what STS signal configuration is to be contained in each OC-3/OC-3c, OC-12/OC-12c, OC-48/OC-48c and OC-192/OC-192c service connection and each STS-1, STS-3 and/or STS-12 payload content. This information is needed for routing and connection purposes in the network. OCN does not extend the SONET data communication channel overhead across the network interface to the customer's equipment.

#### Ethernet over SONET (EoS)

EoS allows the efficient transport of Ethernet frames using SONET. Ethernet Optical Add/Drop capability will be available in bandwidths up to 1 Gbps on an OC-N Point-to-Point. As SONET bandwidths will be preset, the customer will be unable to transmit data beyond these preset SONET bandwidths. Only Single-Mode Fiber is available at the Central Office. The EoS line rates are based on the theoretical SONET payload line rates as per GR-253-CORE, Issue 4. These values are not representative of the true Ethernet transport capacity of the EoS circuit.

OC-3, OC-12, OC-48 and OC-192 based on customer requirements can be configured in any of the following ways:

#### (C) OC-3

- (1) three STS-1 (Synchronous Transport Signals) channels which each contain:
  - (a) one DS3 that is STS-1 mapped; or
  - (b) up to 28 asynchronous DS1s that are VT-mapped; or
  - (c) an STS-1 channel without constraint to payload mapping when the STS-1 channel does not terminate via an add/drop function to DS1 or DS3 services within the network; or

- (d) 1 Gbps Ethernet STS-1 1-2v;
- (2) a single concatenated STS-3C channel.
- (D) OC-12
  - (1) twelve STS-1 channels which each contain:
    - (a) one DS3 that is STS-1 mapped; or
    - (b) up to 28 asynchronous DS1s that are VT-mapped;  
or
    - (c) an STS-1 channel without constraint to payload mapping when the STS-1 channel does not terminate via an add/drop function to DS1 or DS3 services within the network; or
    - (d) 1 Gbps Ethernet STS-1 1-9v; or
    - (e) 1 Gbps Ethernet STS-3c 1-3v;
  - (2) four concatenated STS-3C channels.
  - (3) from one to three STS-3Cs channels mixed with from three to nine STS-1 channels subject to utilization of the total OC-12 capacity.
  - (4) a single concatenated STS-12C channel.

(E) OC-48

- (1) forty-eight STS-1 channels which each contain:
  - (a) one DS3 that is STS-1 mapped; or
  - (b) up to 28 asynchronous DS1s that are VT-mapped; or
  - (c) an STS-1 channel without constraint to payload mapping when the STS-1 channel does not terminate via an add/drop function to DS1 or DS3 services within the network; or
  - (d) 1 Gbps Ethernet STS-1 1-21v; or
  - (e) 1 Gbps Ethernet STS-3c 1-7v;
- (2) sixteen concatenated STS-3C channels.
- (3) from one to fifteen concatenated STS-3C channels, mixed with from three to forty-five STS-1 channels subject to utilization of the total OC-48 capacity.
- (4) four concatenated STS-12Cs channels.
- (5) from one to three concatenated STS-12C channels, mixed with from twelve to thirty-six STS-1 channels subject to utilization of the total OC-48 capacity.
- (6) from one to three concatenated STS-12C channels, mixed with from four to twelve concatenated STS-3C channels, also mixed with from three to thirty-three STS-1 channels subject to utilization of the total OC-48 capacity.
- (7) from one to three concatenated STS-12C channels, mixed with from one to eleven concatenated STS-3C channels, also mixed with from three to thirty-three STS-1 channels, subject to utilization of the total OC-48 capacity.

(F) OC-192

- (1) One hundred ninety two interleaved STS-1 Channels which each contain:
  - (a) one DS3 that is STS-1 mapped; or
  - (b) up to 28 asynchronous DS1s that are VT-mapped; or
  - (c) an STS-1 channel without constraint to payload mapping when the STS-1 channel does not terminate via and Add/Drop Function to DS1 or DS3 services within the network; or
  - (d) 1 Gbps Ethernet STS-1 1-21v; or
  - (e) 1 Gbps Ethernet STS-3c 1-7v;
- (2) Sixty four interleaved concatenated STS-3 channels.
- (3) From one to sixty three interleaved concatenated STS-3c channels, mixed with from three to one hundred eighty nine STS-1 channels, subject to utilization of the total STS-192 capacity.
- (4) Sixteen interleaved concatenated STS-12c channels.
- (5) From one to fifteen interleaved concatenated STS-12c channels mixed with from twelve to one hundred eighty STS-1 channels, subject utilization of the total STS-192 capacity.
- (6) From one to fifteen interleaved concatenated STS-12c channels, mixed with from four to sixty concatenated STS-3c channels subject to utilization of the total STS-192 capacity.
- (7) From one to fifteen interleaved concatenated STS-12c channels, mixed from one to fifty nine concatenated STS-3c channels, also mixed with from three to one hundred seventy seven STS-1 channels, subject to utilization of the total STS-192 capacity.
- (8) Four interleaved concatenated STS-48c channels.

(F) OC-192 (Cont'd)

- (9) From one to three interleaved concatenated STS-48c channels, mixed with from forty eight to one hundred forty four STS-1 Channels, subject to utilization of the total STS-192 capacity.
- (10) From one to three interleaved concatenated STS-48c channels, mixed with from sixteen to forty eight STS-3c channels, subject to utilization of the total STS-192 capacity.
- (11) From one to three interleaved concatenated STS-48c channels, mixed with from four to twelve STS-12c channels, subject to utilization of the total STS-192 capacity.
- (12) From one to three interleaved concatenated STS-48c channels, mixed with from one to forty seven concatenated STS-3c channels, also mixed with from three to one hundred forty one STS-1 channels, subject to utilization of the total STS-192 capacity.
- (13) From one to three interleaved concatenated STS-48c channels, mixed with from one to eleven concatenated STS-12c channels, also mixed with from twelve to one hundred thirty two STS-1 channels, subject to utilization of the total STS-192 capacity.
- (14) From one to three interleaved concatenated STS-48 channels, mixed with from one to eleven concatenated STS-12c channels, also mixed with from four to forty four concatenated STS-3c channels, subject to utilization of the total STS-192 capacity.
- (15) From one to three interleaved concatenated STS-48 channels, mixed with from one to eleven concatenated STS-12c channels, also mixed with from three to one hundred twenty nine STS-1 channels, subject to utilization for the total STS-192 capacity.
- (16) A single concatenated STS-192c channel.

## 21.2 Rate Conditions

This section contains the specific conditions governing the rates and charges which may apply to OCN Point-to-Point Service. The rates and charges in effect at the time the OCN Point-to-Point Service is installed and accepted by the customer are the rates and charges which will be billed to the customer requesting the service. The rates and charges in effect at the time may not be the same as those rates and charges in effect at the time the customer requests the service.

If the Telephone Company initiates rate changes resulting in a decrease of rates for an existing OC-3, OC-12 or OC-48 service with a 1, 3, or 5 year billing period, or for an existing OC-192 service with a 3 or 5 year billing period, those rate changes will be passed along to the customer. Rate changes resulting in an increase of rates for an existing OC-3, OC-12 or OC-48 service with a 1, 3, or 5 year billing period, or for an existing OC-192 service with a 3 or 5 year billing period will not exceed the original rate for that selected billing period. Rate changes may occur as a result of F.C.C. action.

The four basic rate categories for OCN Point-to-Point Service are Local Distribution Channel, Interoffice Transport, Collocation Transport and Optional Features and Functions.

### (A) Local Distribution Channel (LDC)

The Local Distribution Channel (LDC) (same as Channel Termination (CT)) rate category provides for the communications path between a customer designated premise and the serving wire center of that premise. LDCs are only offered without SBC provided and maintained terminal ADM equipment at the customers designated premises and will hand-off basic 2-fiber or 4-fiber optic cables, depending upon the optional feature (as ordered). One LDC is applied per customer designated premises at which the channel is terminated even if collocation exists.

OC-3/OC-3c, OC-12/OC-12c, OC-48/OC-48c and OC-192/OC-192c LDCs provide point-to-point optical interconnection between the Telephone Company Serving Wire Center (SWC) and the customer premises.

The customer is required to provide ADM that is compatible with the Telephone Company central office ADM as is described in Technical Publication GR-253-CORE.

All LDCs comprising a channel must have the same terminating bit rate unless multiplexing is performed at a Telephone Company Hub location.

(B) Interoffice Transport

Interoffice Transport facilities comprised of Fixed and Per Mile rate elements, provide the transmission paths between Serving Wire Centers associated with two customer designated premises or between a Serving Wire Center associated with a customer premises and a Telephone Company Hub location. Four interoffice transport types are available.

OC-3/OC-3c LDCs are interconnected to OC-3/OC-3c transport.  
OC-12/OC-12c LDCs are interconnected to OC-12/OC-12c transport.  
OC-48/OC-48c LDCs are interconnected to OC-48/OC-48c transport.  
OC-192/OC-192c LDCs are interconnected to OC-192/OC-192c transport.

In addition, interoffice transport can be connected between wire centers with Add/Drop multiplexing at a lower OC-N speed than the LDCs, if the transport is between a lower speed Add/Drop Function and:

- another lower speed Add/Drop Function;
- another lower speed Local Distribution Channel;
- a lower speed Dedicated Ring Port;

All of the above terminations must be the same speed as the transport.

(C) Collocation Transport

Collocation Transport provides for the transmission facilities arrangement between a Telephone Company central office frame and a collocation frame located in the Telephone Company Central Office.

There are two components of Collocation Transport.

(1) Inter/Intra Office Fixed

Inter/Intra office fixed rate element provides for the electronic equipment required to terminate a channel between two collocation arrangements located either in the same central office (intra) or in two separate central offices (inter).

(2) Inter Office Per Mile

The Per Mile charge provides for the electronic equipment and facilities necessary to provide the interoffice transport between two collocation arrangements.



The following types of collocation transport are:

OC-3/OC-3c  
OC-12/OC-12c  
OC-48/OC-48c  
OC-192/OC-192c

In addition to the collocation transport charge, one EISCC charge, of the same speed, from Section 18.8.2 will apply per collocation arrangement.

(D) Optional Features and Functions

The following optional features and functions are available:

Central Office Features which consist of:

- Add/drop Multiplexing (ADM)
- Add/drop function (ADM function)

OC-N Network Survivability which consist of:

- 1+1 Protection
- 1+1 Protection with Cable Survivability
  
- 1+1 Protection with Route Survivability

Regenerators which consist of:

- OC-48
- OC-192

Major Optional Features and Functions, which consist of:

- Connection Arrangements
  - Shared Network Arrangement

(1) Add/Drop Multiplexing

Add/Drop multiplexing is an arrangement in a Telephone Company central office that allows non-concatenated OC-3, OC-12, OC-48 or OC-192 channels operating at a terminating speed of 155.52 Mbps, 622.08 Mbps, 2488.32 Mbps or 9953.28 Mbps, respectively, to add/drop a lower speed channel by using this feature along with the add/drop function as set forth in Section 21.2(D)(2).

(T)

The mix of multiplexing signals cannot exceed the maximum bandwidth of the higher speed OCN circuit terminating on the Central Office multiplexer.

For example, OC-3 add/drop multiplexing at a Telephone Company wire center will provide the capability to support the full add/drop function capacity of OC-3 Service bandwidth with up to 3 DS3 add/drop functions or equivalently up to 3 groups of 28 DS1 add/drop functions.

At the time of ordering any of the following basic rate categories, the customer must provide configuration information for the entire multiplexing option at the time the order for service is placed. In addition, concatenated services OC-3, OC-12 or OC-48 cannot be ordered under the central office feature section as the Telephone Company cannot convert individual STS-1 signals to concatenated (non-channelized) channels.

OC-12 add/drop multiplexing at a Telephone Company wire center will provide the capability to support the full add/drop function capacity of OC-12 service bandwidth with up to 4 OC-3 add/drop functions or up to twelve DS3 add/drop functions or equivalent combinations of OC-3 and DS3 add/drop functions.

If asynchronous DS1 ports are required on a OC-12 OCN circuit, then the OC-3 add/drop multiplexing feature and associated DS1 add/drop function must be ordered in addition to the OC-12 add/drop multiplexing feature.

OC-48 add/drop multiplexing at a Telephone Company wire center will provide the capability to support the full add/drop function capacity of OC-48 service bandwidth with up to 4 OC-12 add/drop functions or up to forty-eight DS3 add/drop functions or equivalent combination of OC-3 and DS3 add/drop functions. If DS1's are required for the OC-12 then the preceding guidelines established can be followed.

OC-192 add/drop multiplexing at a Telephone Company wire center will provide the capability to support full add/drop function capacity of OC-192 service bandwidth. Up to four OC-48 add/drop functions, or up to 16 OC-12 add/drop functions, or up to 64 OC-3 add/drop functions or equivalent combinations of OC-48, OC-12 and OC-3 add/drop functions are supported.

(2) Add/Drop Function

The OC-3, OC-12, OC-48 and OC-192 are able to add or drop lower level signals as shown in the matrix following. The add/drop function is offered at a circuit level. For example, if a customer wants to drop one DS3 signal from an OC-12 service, they would pay one add/drop function charge for the DS3 and the initial OC-12 add/drop multiplexing charge.

An OC-3, OC-12, OC-48 and OC-192 is only able to add or drop the services that have been identified by payload content (mapping) within the bandwidth. DS1 mapped STS-1 signals are only able to connect to a DS1, and a DS3 mapped STS-1 signals are only able to connect to a DS3. If a change is required it may be accomplished by the customer's CPE or through the current asynchronous environment for multiplexing of DS3 and DS1 services stated in Section 7.11 of Tariff F.C.C. No. 1.

Once the options in (1) and (2) above are specified by the customer they cannot be used with OC-3, OC-12 or OC-48 configured by the customer to contain a single non-channelized (concatenated) STS-3C or STS-12C signal, respectively.

Ethernet over SONET (EoS) is supported by an Add/Drop function. The quantities allowed will depend upon the VT or STS bandwidth assigned over the port.

ADD/DROP Function

	DS1	DS3	OC-3	OC-12	OC-48	1000 Base LX
OC-192	No	No	Yes	Yes	Yes	Yes
OC-48	No	Yes	Yes	Yes	N/A	Yes
OC-12	No	Yes	Yes	N/A	N/A	Yes
OC-3	Yes	Yes	N/A	N/A	N/A	Yes

(3) OCN Point-to-Point Network Survivability

There are 4 components of OCN Network Survivability:

- (a) 1+1 Protection
- (b) 1+1 Protection with Cable Survivability
- (c) 1+1 Protection with Route Survivability
- (d) 1+1 Protection with Diversity

(a) 1+1 Protection

This option provides two identical fiber pairs that are placed in the same cable and follows the same route. If the working pair fails, traffic shifts to the protected fiber pair. This option does not protect against a fiber cable cut.

The protected OC-3/OC-3c, OC-12/OC-12c, OC-48/OC-48c and OC-192/OC-192c Services are offered with four fibers in the same cable and the protection card is activated when this option is ordered.

(b) 1+1 Protection with Cable Survivability

With this option, the working fiber pairs and the protected fiber pairs are located in two separate cables within the same conduit. If the working fiber pair cable experiences damages or a fiber cut, traffic will switch to the protected fiber pair in a separate cable. These cables are located in the same conduit, if the conduit is cut, there is no protection.

This option will provide 1+1 protection and additional loop survivability with the working fiber pair and protect fiber pair placed in separate cables within the same conduit.

(c) 1+1 Protection with Route Survivability

This option will provide 1+1 protection and offer additional protection from fiber cable cuts by routing the working fiber pair via the primary route and the protected fiber pair via a physically diverse alternate route.

The protected fiber will be charged on a distance sensitive basis, in addition to the protection optical charge and will be based on quarter route miles, from the customer premises to the serving wire center.

This is the only option that will assure 100 percent availability of the service. Any service interruption will result in a credit equal to one month's bill for the circuit involved. If the interruption occurs on a Local Distribution Channel without this option, normal terms and conditions for out of service credits as stated in Part 2, Section 2 of this Guidebook, will apply. An interruption period will start when an inoperative service is reported to the Telephone Company and end when the service is operative. In any month, as a result of an interruption, the total credit per rate element of the interrupted service may not exceed 100 percent of the monthly charge for that particular rate element.

(T)

All other terms and conditions for Credit Allowances as stated in Part 2, Section 2 of this Guidebook, will apply.

(T)

Prior to confirming an order for service, the Telephone Company will provide a proposed route diagram to the customer. The diagram will include the number of quarter route miles and method used to support the number needed to provide the alternate route. In order to avoid compromising Route Survivability information, the Telephone Company will provide this information only to the ordering customer.

Installation of the 1+1 protection with Route Survivability option will not begin until the customer has accepted the proposed routing by the Telephone Company.

<sup>(1)</sup> OCN Point-to-Point Network Survivability is available on OC-3/OC-3c, OC-12/OC-12c and OC-48/OC-48c Services only.

(d) Diversity

This option will provide end-to-end diversity from A-Z for the second like service. It requires a charge for mileage on a "per Quarter Route Mile" basis, for each customer premises or Local Distribution Channel (LDC), only when both circuits terminate at the same customer premises. The standard OCN PTP service is provided without protection, but it is still an option with Diversity. 1+1 Protection is defined above and rates will apply as stated in Diversity Sections 21.3(A)(4)(g)-(OC-3), 21.3(B)(4)(g)-(OC-12), 21.3(C)(4)(h)-(OC-48) and 21.3(D)(4)(g)-(OC-192). For the inter-office portion, the Diversity rate will cover any additional air-line mileage between serving wire centers.

(T)

(D)

This is the only option that will assure 100% availability from end-to-end of the service. Any service interruption of both services at the same time will result in a credit of one month's bill for the second circuit. If the interruption occurs on a section of the service where commonality has been identified to the customer, normal terms and conditions for out of service credits, as stated in Part 2, Section 2 of this Guidebook, will apply. An interruption period will start when an inoperative service is reported to the Telephone Company, and end when the service is operative. In any month, as a result of an interruption, the total credit per rate element of the interrupted service may not exceed 100 percent of the monthly charge for that particular rate element.

All other terms and conditions for Credit Allowances, as stated in Part 2, Section 2 of this Guidebook, will apply.

Prior to confirming an order for service, the Telephone Company will provide a proposed route diagram to the customer. The diagram will include the number of quarter route miles and method used to support the number needed to provide the alternate route. In order to avoid compromising Route Survivability information, the Telephone Company will provide this information only to the ordering customer.

Installation of the Diversity option will not begin until the customer has accepted the proposed routing by the Telephone Company.

<sup>(1)</sup> OCN Point-to-Point Network Survivability is available on OC-3/OC-3c, OC-12/OC-12c and OC-48/OC-48c Services only.

The following diagrams provide an example of (a), (b), (c) and (d) above:

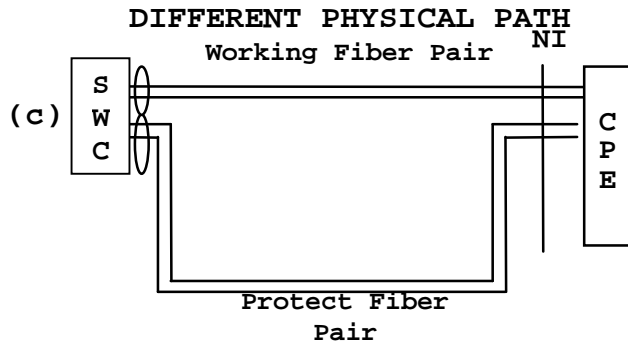
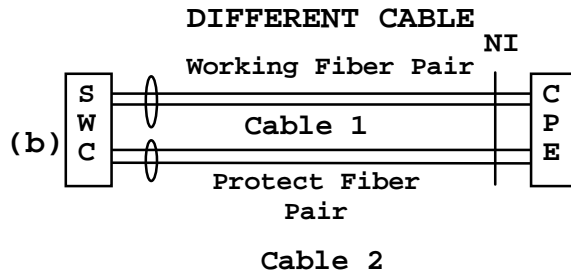
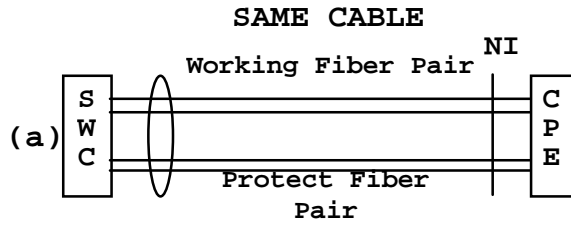
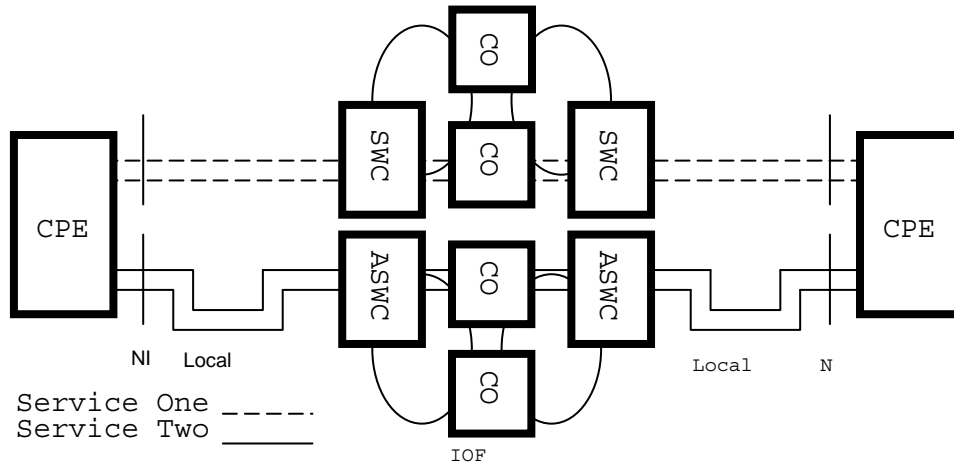

Diagram (d):

OC-N PTP Survivability with Diversity (Two Circuits Diverse E-E, same locations)





(4) Point-to-Point OC-48 and OC-192 Regenerator

Regenerators provide essential detection and retransmission of SONET Optical 2488.32 Mbps and 9953.28 Mbps signals between customer premises. Regenerators will only be provided as required by the Telephone Company when actual fiber facility distances between customer designated premises and/or central office locations exceed design limits (typically 25 to 30 miles). Regenerators will be located exclusively in Telephone Company central offices.

(5) Connection Arrangement(a) Shared Network Arrangement<sup>(1)</sup>

- A Shared Network Arrangement is a service offering that enables a customer ("Service User") to connect subtending services to the multiplexed OC-3, OC-12 or OC-48 service of another customer (the "Host Subscriber"), with the Telephone Company maintaining separate billing for each. Each customer will be billed for those rate elements associated with their own portion of the service configuration. Under no circumstances will the rates or charges for individual rate elements be split. This offering is limited to service configurations where a Service User obtains either subtending DS3 or DS1 from a Host's multiplexed OC-3 service or an OC-3 service from a Host's multiplexed OC-12 service or an OC-12 service from a Hosts' multiplexed OC-48 service.
- Under the Shared Network Arrangement, the Telephone Company may share record information with the Host subscriber pertaining to the services of other users of the shared network. Such disclosure will be under the sole discretion of the Telephone Company and is necessary to perform billing reconciliation and/or other functions required in connection with maintaining account records.
- A nonrecurring charge, only, will apply to the Shared Network Arrangement.

(6) Network Channel Interfaces

The network channel interfaces define the bit rates that are available for OC-3/OC-3c, OC-12/OC-12c, OC-48/OC-48c and OC-192/OC-192c services operating at speeds of 155.52 Mbps, 622.08 Mbps, 2488.32 Mbps and 9953.28 Mbps. Network Channel interfaces and codes are described in Part 2, Section 7 of this Guidebook. (T)

(1) Effective 05/26/06, this condition is limited to existing customers. For new customers purchasing Shared Network Arrangement, terms and conditions set forth in Part 2, Section 5 of this Guidebook, will apply. (T)

(E) Monthly Extension Rates<sup>(1)</sup>

At the expiration of the TPP term and if the customer wishes to continue OC-3/OC-3c, OC-12/OC-12c, OC-48/OC-48c or OC-192/OC-192c, the customer may select a new TPP at the prevailing TPP rate.

If a customer does not wish to renew the TPP at the expiration of the term, the Monthly Extension Rates will apply until the customer cancels or renews the service with a new TPP term. Monthly Extension Rates are not available as an individual TPP and are to be used as a default applied at the end of a regular 1 year (12 month), 3 year (36 month) and 5 year (60 month) TPP.

(F) Nonrecurring Charges

One-time charges that apply for a specific work activity, e.g., installation, rearrangements, moves, etc., as described in Part 2, Section 7 of this Guidebook.

(G) Minimum Periods

The Minimum Period for OC-3, OC-12 and OC-48 OCN Point-to-Point Service is one year and the minimum period for OC-192 OCN Point-to-Point Service is three years. In the event OCN Point-to-Point Service is terminated prior to completion of the minimum period, termination liabilities as described in Section 21.2(I) will apply.

<sup>(1)</sup> All term plans for OCN Point-to-Point Service which are established or renewed after November 9, 2013, for term lengths which are scheduled to expire at any time after December 31, 2017, will instead expire on December 31, 2017. All such services existing on or after December 31, 2017, will be provided on a month-to-month basis at the applicable, then current month-to-month rates. Notwithstanding anything to the contrary in the previous two sentences, this footnote does not apply to any term plans established or renewed after January 22, 2016.

(N)  
(N)

(H) Term Pricing Plans (TPP)<sup>(1)</sup>

(1) General Description

Term Pricing Plans (TPP) are available on Local Distribution Channels, Interoffice Transport, Collocation Transport and Add/Drop Multiplexing rate elements. The TPP stabilizes rates for OCN Point-to-Point Service for the specified period of time. The following TPPs are available:

- One Year (12 Month) TPP - OC-3, OC-12 and OC-48,
- Three Year (36 Month) TPP - OC-3, OC-12, OC-48 and OC-192, or
- Five Year (60 Month) TPP - OC-3, OC-12, OC-48 and OC-192.

(2) Modifications

When additional like-speed OCN Point-to-Point Service circuits are purchased, the customer may include the additional circuits in an existing TPP if:

- The customer renegotiates their TPP for a period of time equal to or greater than the time remaining on the existing TPP;
- The circuits are the same speed; and
- The circuits are located between the same customer designated premises.

(3) Renewals

At the end of a TPP period, the customer must select one of the following options within one month prior to the expiration date:

- a. Renew the service for a one, three or five year TPP as provided in this Guidebook;
- b. Elect to disconnect the service upon expiration of the billing period; or
- c. Continue the service on a monthly basis at the current monthly extension rates.

All services under an existing TPP that are not renewed within the period stated above will revert to Option (3)c above and be billed at the current monthly extension rates.

<sup>(1)</sup> All term plans for OCN Point-to-Point Service which are established or renewed after November 9, 2013, for term lengths which are scheduled to expire at any time after December 31, 2017, will instead expire on December 31, 2017. All such services existing on or after December 31, 2017, will be provided on a month-to-month basis at the applicable, then current month-to-month rates. Notwithstanding anything to the contrary in the previous two sentences, this footnote does not apply to any term plans established or renewed after January 22, 2016. (N)  
(N)

(4) Conversions

If there is at least one month remaining on an existing 1 or 3 year OCN Point-to-Point TPP, the customer may convert the service to a higher term OCN Point-to-Point TPP without termination liability and, at the time of the access order to convert, retain the service for the period remaining on the higher term OCN Point-to-Point TPP. No retroactive OCN Point-to-Point TPP discounts will apply prior to the order date.

For example; a customer with an existing 3 Year OCN Point-to-Point TPP with 11 months remaining elects to convert to a 5 Year OCN Point-to-Point TPP. At the time of the order, the customer will begin paying the 5 year OCN Point-to-Point TPP rate for the remaining period of 2 years and 11 months (35 months) on the new TPP.

(5) Transitioning from Other Special Access Services to OCN Point-to-Point

The customer may, at any time, move other existing Telephone Company Special Access Services to an OCN Point-to-Point service provided the following conditions are met for the new OCN Point-to-Point circuit being ordered.

The new OCN Point-to-Point circuit must:

- (a) Be the same speed and configuration as the existing service being disconnected.
- (b) Be located between the same two customer designated premises or between the same customer designated premises and the Serving Wire Center.
- (c) Have a minimum billing period that is greater or equal to the remaining billing period revenue for the existing service. (D)
- (d) Represent equal or greater of the total minimum billing period revenue as the remaining billing period revenue of the existing service. (D)

(I) Termination Liability<sup>(1)</sup>

Customer requesting termination of service prior to the expiration date of the OCN Point-to-Point TPP will be liable for a termination charge. The termination charge for all TPP terms with an Optical Interface, will be calculated as follows:

Billing Period Termination Percentage

1, 3, or 5 years 50%

The termination liability is calculated as follows:

(Monthly recurring X Months remaining X (Termination  
rate) in billing) percentage)

Example:

An OCN Point-to-Point customer with a \$20,000 monthly rate terminates service after 2 years with 1 year (12 months) remaining in a 3 year TPP. The termination liability would be calculated as:

$$\$20,000 \times 12 \times .50 = \$120,000 \text{ Termination Liability}$$

A termination charge will not apply under the following conditions and circumstances:

1. Moves as set forth under "Moves" without decreasing number of OCN PTP circuits
2. Modifications of services as described in the Guidebook
3. Conversions to other special access service if
  - a. service is same or higher
  - b. billing period same or greater
  - c. billing period revenue for the special access service is greater than or equal to the OCN PTP billing period revenue.

(J) Moves

Moves involve a change in the physical location of one of the following:

- Service rearrangement;
- Point of Termination with in the same customer premises;
- or
- Customer's premises.

Move charges are dependent upon the type of move requested by the customer.

<sup>(1)</sup> All term plans for OCN Point-to-Point Service which are established or renewed after November 9, 2013, for term lengths which are scheduled to expire at any time after December 31, 2017, will instead expire on December 31, 2017. All such services existing on or after December 31, 2017, will be provided on a month-to-month basis at the applicable, then current month-to-month rates. Notwithstanding anything to the contrary in the previous two sentences, this footnote does not apply to any term plans established or renewed after January 22, 2016. (N)  
(N)

(1) Service Rearrangement

Service Rearrangements are changes to existing (installed) services which do not result in either (1) a change in the minimum period requirements or (2) a change in the physical location of the point of termination at a customer designated premises as described in Part 2, Section 7 of this Guidebook.

(T)

(2) Moves of the Point of Termination Within the Same Customer Premises

When the move of the Point of Termination is to a new location within the same customer premises, the move will be treated as an extension of access service facilities as described in Part 2, Section 7 of this Guidebook.

(T)  
(T)(3) Moves of a Customer Premises

Moves to a different customer premises will be treated as a discontinuance and start of service as described in Part 2, Section 7 of this Guidebook.

(T)

(K) Mileage Measurement

The application of distance sensitive rates requires the determination of the airline distance between a serving wire Center (SWC) and an end office or two or more serving wire center (SWC) locations as described in Part 2, Section 7 of this Guidebook.

(T)  
(T)(L) Modification of Access Service

The customer may request a modification of an access order at any time prior to notification by the Telephone Company that service is available for the customer's use. The Telephone Company will make every effort to accommodate a requested modification when it is able to do so with the normal work force assigned to complete such an order within normal business hours. If the modification cannot be made with the normal work force during normal business hours, the Telephone Company will notify the customer. If the customer still desires the access order modification, the Telephone Company will schedule a new service date. All charges for access order modifications will apply on a per order, per occurrence basis as described in Part 2, Section 5 of this Guidebook.

(T)

(M) Shared Use

Shared use occurs when Special Access Service and Switched Access Service are provided over the same Wideband Analog or DS1 or DS3 facilities or SONET based services through a common interface. The facility will be ordered, provided and rated as Special Access Service (e.g., Local Distribution Channel, DS3 Service Packages, DS3 Service Channels, Channel Mileage Terminations and Channel Mileage, as appropriate, and Multiplexing).

The nonrecurring charge that applies when the Shared Use Facility is installed will be the nonrecurring charge associated with the installation of the appropriate Special Access Wideband Analog or DS1 or DS3 facility or SONET based service. Individual service (i.e., Switched or Special Access) nonrecurring charges will not apply to the individual channels of the Shared Use Facility. Rating as Special Access will continue until such time as the customer chooses to use a portion of the available capacity for providing Switched Access Transport Service from the office where multiplexing occurs to either an end office or an access tandem.

(N) Jointly Provided Service

Jointly Provided Service is also referred to as "meet-point-billing" arrangements as described in Part 2, Section 2 of this Guidebook.

(O) Ordering Options and Conditions

The ordering options and conditions sets forth the order related charges for ordering Access Service as described in Part 2, Section 5 of this Guidebook.

(P) Upgrade to OCN Point-to-Point from lower speeds

Customers with one, three or five year OCN Point-to-Point TPPs may at any time upgrade to OCN Point-to-Point service (e.g., OC-12 to OC-48) without incurring the Termination Liability charge, providing the following criteria are met: (D)

- The customer subscribes to a Term Pricing Plan period that is equal to, or greater than 12 months;
- The expiration date for the new Term Pricing Plan period is beyond the end of the original Term Pricing Plan period;



- No lapse in service occurs;
- 100% of any waived or unamortized nonrecurring charges will apply, when applicable;
- The monthly rates for the new service(s) will be those rates in effect at the time the new service(s) is/are installed;
- The new service is provided between the same customer locations and with the same customer of record as the disconnected service; and
- The billed monthly recurring revenue for the new service is equal to or greater than the billed monthly recurring revenue remaining in the service being converted.

21.3 Rates and Charges

(A) OC-3/OC-3c

(1) Local Distribution Channel

-Per Point of Termination

<u>USOC</u>	<u>1 Year</u> <sup>(1)</sup>	<u>3 year</u> <sup>(1)</sup>	<u>5 year</u> <sup>(1)</sup>	<u>Mo. Ext.</u>
TMECS	\$2,100.00	\$1,700.00	\$1,300.00	\$2,503.00

(2) Interoffice Transport

	<u>USOC</u>	<u>1 Year</u> <sup>(1)</sup>	<u>3 year</u> <sup>(1)</sup>	<u>5 year</u> <sup>(1)</sup>	<u>Mo. Ext.</u>
-Mileage					
-Fixed	1L5XX	\$1,100.00	\$900.00	\$800.00	\$2,200.00
-Per Mile	1L5XX	\$260.00	\$250.00	\$200.00	\$385.00

(3) Collocation Transport-Transport Facilities between Collocation Arrangements

	<u>USOC</u>	<u>1 Year</u> <sup>(1)</sup>	<u>3 year</u> <sup>(1)</sup>	<u>5 year</u> <sup>(1)</sup>	<u>Mo. Ext.</u>
-Fixed	1H48S	\$1,100.00	\$900.00	\$800.00	\$2,200.00
-Per Mile	1H48S	\$260.00	\$250.00	\$200.00	\$385.00

(4) Optional Features and Functions

(a) OC-3 Add/Drop Multiplexing-Per Arrangement\*

<u>USOC</u>	<u>1 Year</u> <sup>(1)</sup>	<u>3 year</u> <sup>(1)</sup>	<u>5 year</u> <sup>(1)</sup>	<u>Mo. Ext.</u>
MPECX	\$1,500.00	\$1,200.00	\$950.00	\$1,650.00

(b) Add/Drop Function-Per DS-3

<u>USOC</u>	<u>Monthly</u>	<u>Nonrecurring Charge</u>
MXJBX	\$150.00	\$0

\* Concatenated services cannot be multiplexed.

<sup>(1)</sup> All term plans for OCN Point-to-Point Service which are established or renewed after November 9, 2013, for term lengths which are scheduled to expire at any time after December 31, 2017, will instead expire on December 31, 2017. All such services existing on or after December 31, 2017, will be provided on a month-to-month basis at the applicable, then current month-to-month rates. Notwithstanding anything to the contrary in the previous two sentences, this footnote does not apply to any term plans established or renewed after January 22, 2016. (N)  
(N)

	<u>USOC</u>	<u>Monthly</u>	<u>Nonrecurring Charge</u>	
(4) <u>Optional Features and Functions</u> (Cont'd)				
(b) <u>Add/Drop Function</u> (Cont'd)				
-Per DS1	MXJAX	\$25.00	\$0	
-Per 1000 Base LX	MX4LX	\$500.00	\$0	
(c) <u>1+1 Protection</u> -Per OC-3/OC-3c Customer Premises	P8T	\$180.00	\$0	(C)
(d) <u>1+1 Protection with Cable Survivability</u> -Per OC-3/OC-3c Customer Premises	P3S	\$180.00	\$500.00	(C)
(e) <u>1+1 Protection with Route Survivability</u> -Per OC-3/OC-3c Customer Premises		(Apply P8T rate above, P8T plus Per Quarter Route Mile below) (P8T + S2DXY)		(C)
-Per Quarter Route Mile	S2DXY	\$50.00	\$0	

	<u>USOC</u>	<u>Monthly</u>	<u>Nonrecurring Charge</u>	
(4) <u>Optional Features and Functions</u> (Cont'd)				
(f) <u>Shared Network Arrangement</u> -Processing Charge per Service Order	NRBOP	\$0	\$30.00	
(g) Diversity <sup>(1)</sup> -Per Quarter Route Mile	S2DXY	\$50.00	\$0	
-Per OC-3/OC-3c	CPAPA	\$200.00	\$0	
(5) <u>Moves (OC-3/OC-3c)</u>				
(a) <u>Service Rearrangement</u>				
See Part 2, Section 7 of this Guidebook, for rates and charges.				(T)
(b) <u>Moves of Point of Termination</u>				
See Part 2, Section 13 of this Guidebook, for rates and charges.				(T)
(c) <u>Moving Customer Premises</u>				
See Part 2, Section 7 of this Guidebook, for rates and charges.				(T)

<sup>(1)</sup> The Per Quarter Route Mile is required for one or both ends of the second service when both services terminate at the same customer premises.

(B) OC-12/OC-12c

(1) Local Distribution Channel

-Per Point of Termination

<u>USOC</u>	<u>1 Year</u> <sup>(1)</sup>	<u>3 year</u> <sup>(1)</sup>	<u>5 year</u> <sup>(1)</sup>	<u>Mo. Ext.</u>
TMECS	\$4,560.00	\$4,000.00	\$3,000.00	\$5,775.00

(2) Interoffice Transport

-Mileage

<u>USOC</u>	<u>1 Year</u> <sup>(1)</sup>	<u>3 year</u> <sup>(1)</sup>	<u>5 year</u> <sup>(1)</sup>	<u>Mo. Ext.</u>
-Fixed 1L5XX	\$3,420.00	\$2,800.00	\$2,150.00	\$4,510.00
-Per Mile 1L5XX	\$247.00	\$250.00	\$200.00	\$385.00

(3) Collocation Transport-Transport Facilities between Collocation Arrangements

<u>USOC</u>	<u>1 Year</u> <sup>(1)</sup>	<u>3 year</u> <sup>(1)</sup>	<u>5 year</u> <sup>(1)</sup>	<u>Mo. Ext.</u>
-Fixed 1H48S	\$3,600.00	\$2,800.00	\$2,150.00	\$4,510.00
-Per Mile 1H48S	\$260.00	\$250.00	\$200.00	\$385.00

(4) Optional Features and Functions

(a) OC-12 Add/Drop Multiplexing-Per Arrangement\*

<u>USOC</u>	<u>1 Year</u> <sup>(1)</sup>	<u>3 year</u> <sup>(1)</sup>	<u>5 year</u> <sup>(1)</sup>	<u>Mo. Ext.</u>
MPEDX	\$3,200.00	\$2,800.00	\$2,100.00	\$3,575.00

(b) Add/Drop Function-Per OC-3

<u>USOC</u>	<u>Monthly</u>	<u>Nonrecurring Charge</u>
MXJCX	\$250.00	\$150.00

\* Concatenated services cannot be multiplexed.

<sup>(1)</sup> All term plans for OCN Point-to-Point Service which are established or renewed after November 9, 2013, for term lengths which are scheduled to expire at any time after December 31, 2017, will instead expire on December 31, 2017. All such services existing on or after December 31, 2017, will be provided on a month-to-month basis at the applicable, then current month-to-month rates. Notwithstanding anything to the contrary in the previous two sentences, this footnote does not apply to any term plans established or renewed after January 22, 2016. (N)  
 (N)

	<u>USOC</u>	<u>Monthly</u>	<u>Nonrecurring Charges</u>	
(4) <u>Optional Features and Functions</u> (Cont'd)				
(b) <u>Add/Drop Function</u> (Cont'd)				
-Per DS3	MXJBX	\$150.00	\$150.00	
-Per 1000 Base LX	MX4LX	\$500.00	\$0.00	
(c) <u>1+1 Protection</u> -Per OC-12/OC-12c Customer Premises	P8T	\$260.00	\$150.00	(C) (C)
(d) <u>1+1 Protection with Cable Survivability</u> -Per OC-12/OC-12c Customer Premises	P3S	\$260.00	\$600.00	(C) (C)
(e) <u>1+1 Protection with Route Survivability</u> -Per OC-12/OC-12c Customer Premises	P8T	(Apply P8T rate above, plus Per Quarter Route Mile below) (P8T + S2DXY)		(C) (C)
-Per Quarter Route Mile	S2DXY	\$100.00	\$150.00	

	<u>USOC</u>	<u>Monthly</u>	<u>Nonrecurring Charge</u>
(4) <u>Optional Features and Functions</u> (Cont'd)			
(f) <u>Shared Network Arrangement</u> -Processing Charge per Service Order	NRBOP	\$0	\$30.00
(g) <u>Diversity</u> <sup>(1)</sup>			
-Per Quarter			
Route Mile	S2DXY	\$100.00	\$0
-Per OC-12/OC-12c	CPAPB	\$300.00	\$0
(5) <u>Moves (OC-12/OC-12c)</u>			
(a) <u>Service Rearrangements</u>			
See Part 2, Section 7 of this Guidebook, for rates and charges.			(T)
(b) <u>Moves of Point of Termination</u>			
See Part 2, Section 13 of this Guidebook, for rates and charges.			(T)
(c) <u>Moving Customer Premises</u>			
See Part 2, Section 7 of this Guidebook, for rates and charges.			(T)

<sup>(1)</sup> The Per Quarter Route Mile is required for one or both ends of the second service when both services terminate at the same customer premises.

(C) OC-48/OC-48c

(1) Local Distribution Channel

Per Point of Termination

<u>USOC</u>	<u>1 Year</u> <sup>(1)</sup>	<u>3 year</u> <sup>(1)</sup>	<u>5 year</u> <sup>(1)</sup>	<u>Mo. Ext.</u>
TMECS	\$10,830.00	\$9,800.00	\$7,000.00	\$13,475.00

(2) Interoffice Transport

	<u>USOC</u>	<u>1 Year</u> <sup>(1)</sup>	<u>3 year</u> <sup>(1)</sup>	<u>5 year</u> <sup>(1)</sup>	<u>Mo. Ext.</u>
-Mileage					
-Fixed	1L5XX	\$6,365.00	\$5,250.00	\$4,150.00	\$8,663.00
-Per Mile	1L5XX	\$285.00	\$250.00	\$200.00	\$385.00

(3) Collocation Transport—Transport Facilities between Collocation Arrangements

	<u>USOC</u>	<u>1 Year</u> <sup>(1)</sup>	<u>3 year</u> <sup>(1)</sup>	<u>5 year</u> <sup>(1)</sup>	<u>Mo. Ext.</u>
-Fixed	1H48S	\$6,700.00	\$5,250.00	\$4,150.00	\$8,663.00
-Per Mile	1H48S	\$300.00	\$250.00	\$200.00	\$385.00

(4) Optional Features and Functions

(a) OC-48 Add/Drop Multiplexing—Per Arrangement\*

<u>USOC</u>	<u>1 Year</u> <sup>(1)</sup>	<u>3 year</u> <sup>(1)</sup>	<u>5 year</u> <sup>(1)</sup>	<u>Mo. Ext.</u>
MXRFX	\$5,550.00	\$4,625.00	\$3,700.00	\$6,375.00

(b) Add/Drop Function—Per OC-3

<u>USOC</u>	<u>Monthly</u>	<u>Nonrecurring Charge</u>
MXJEX	\$625.00	\$0

\* Concatenated services cannot be multiplexed.

<sup>(1)</sup> All term plans for OCN Point-to-Point Service which are established or renewed after November 9, 2013, for term lengths which are scheduled to expire at any time after December 31, 2017, will instead expire on December 31, 2017. All such services existing on or after December 31, 2017, will be provided on a month-to-month basis at the applicable, then current month-to-month rates. Notwithstanding anything to the contrary in the previous two sentences, this footnote does not apply to any term plans established or renewed after January 22, 2016. (N)  
(N)



	<u>USOC</u>	<u>Monthly</u>	<u>Nonrecurring Charge</u>	
(4) <u>Optional Features and Functions</u> (Cont'd)				
(b) <u>Add/Drop Function</u> (Cont'd)				
-Per OC-3	MXJCX	\$250.00	\$0	
-Per DS3	MXJBX	\$150.00	\$0	
-Per 1000 Base LX	MX4LX	\$500.00	\$0	
(c) <u>1+1 Protection</u> -Per OC-48/OC-48c				
Customer Premises	P8T	\$1,410.00	\$0	(C) (C)
(d) <u>1+1 Protection with Cable Survivability</u> -Per OC-48/OC-48c				
Customer Premises	P3S	\$1,410.00	\$700.00	(C) (C)
(e) <u>1+1 Protection with Route Survivability</u> -Per OC-48/OC-48c				
Customer Premises	P8T	(Apply P8T rate above, plus Per Quarter Route Mile below) (P8T + S2DXY)		(C) (C)
-Per Quarter Route Mile	S2DXY	\$125.00	\$0	

	<u>USOC</u>	<u>Monthly</u>	<u>Nonrecurring Charge</u>
(4) <u>Optional Features and Functions</u> (Cont'd)			
(f) <u>Point-to-Point OC-48 Regenerator</u> -each	RGY48	\$5,500.00	\$0
(g) <u>Shared Network Arrangement</u> -Processing Charge per Service Order	NRBOP	\$0	\$30.00
(h) <u>Diversity<sup>(1)</sup></u> -Per Quarter Route Mile	S2DXY	\$125.00	\$0
-Per OC-48/OC-48c	CPAPC	\$700.00	\$0
(5) <u>Moves (OC-48/OC-48c)</u>			
(a) <u>Service Rearrangement</u>			
See Part 2, Section 7 of this Guidebook, for rates and charges.			(T)
(b) <u>Moves of Point of Termination</u>			
See Part 2, Section 13 of this Guidebook, for rates and charges.			(T)
(c) <u>Moving Customer Premises</u>			
See Part 2, Section 7 of this Guidebook, for rates and charges.			(T)

<sup>(1)</sup> The Per Quarter Route Mile is required for one or both ends of the second service when both services terminate at the same customer premises.

(D) <u>OC-192/OC-192c</u>		<u>USOC</u>	<u>3 year<sup>(1)</sup></u>	<u>5 year<sup>(1)</sup></u>	<u>Mo. Ext.</u>
(1)	<u>Local Distribution Channel</u> -Per Point of Termination	TMECS	\$24,900.00	\$17,800.00	\$39,600.00
(2)	<u>Interoffice Transport</u> -Mileage -Fixed	1L5XX	\$16,000.00	\$13,000.00	\$25,988.00
	-Per Mile	1L5XX	\$350.00	\$300.00	\$495.00
(3)	<u>Collocation Transport</u> -Transport Facilities between Collocation Arrangements -Fixed	1H48S	\$16,000.00	\$13,000.00	\$25,988.00
	-Per Mile	1H48S	\$350.00	\$300.00	\$495.00
(4)	<u>Optional Features and Functions</u>				
(a)	OC-192 Add/Drop Multiplexing*				
	-Per Arrangement	MXRGX	\$12,000.00	\$9,600.00	\$16,800.00
(b)	Add/Drop Function	<u>USOC</u>	<u>Monthly</u>	<u>Nonrecurring Charge</u>	
	-per OC-48	MXJFX	\$1,800.00		\$0

\*Concatenated services cannot be multiplexed.

<sup>(1)</sup> All term plans for OCN Point-to-Point Service which are established or renewed after November 9, 2013, for term lengths which are scheduled to expire at any time after December 31, 2017, will instead expire on December 31, 2017. All such services existing on or after December 31, 2017, will be provided on a month-to-month basis at the applicable, then current month-to-month rates. Notwithstanding anything to the contrary in the previous two sentences, this footnote does not apply to any term plans established or renewed after January 22, 2016. (N)  
(N)

	<u>USOC</u>	<u>Monthly</u>	<u>Nonrecurring Charge</u>	
(4) <u>Optional Feature and Functions</u> (Cont'd)				
(b) <u>Add/Drop Function</u> (Cont'd)				
-Per OC-12	MXJEX	\$625.00	\$0	
-Per OC-3	MXJCX	\$250.00	\$0	
-Per 1000 Base LX	MX4LX	\$500.00	\$0	
(c) <u>1+1 Protection</u> -Per OC-192/ OC-192c Customer Premises	P8T	\$2,700.00	\$0	(C) (C)
(d) <u>1+1 Protection with Cable Survivability</u> -Per OC-192/ OC/192c Customer Premises	P3S	\$2,700.00	\$800.00	(C) (C)
(e) <u>1+1 Protection with Route Survivability</u> -Per OC-192/ OC-192c Customer Premises	P8T	(Apply P8T rate above, plus Per Quarter Route Mile below) (P8T + S2DXY)		(C) (C)
-Per Quarter Route Mile	S2DXY	\$150.00	\$0	
(f) <u>Point-to-Point OC-192 Regenerator</u>				
-each	RGY	\$11,000.00	\$0	
(g) <u>Diversity</u> <sup>(1)</sup> -Per Quarter Route Mile	S2DXY	\$150.00	\$0	
-Per OC-192/ OC-192c	CPAPD	\$1200.00	\$0	

<sup>(1)</sup> The Per Quarter Route Mile is required for one or both ends of the second service when both services terminate at the same customer premises.

(5) Moves (OC-192/OC-192c)

(a) Service Rearrangement

See Part 2, Section 7 of this Guidebook, for rates and charges. (T)

(b) Moves of Point of Termination

See Part 2, Section 13 of this Guidebook, for rates and charges. (T)

(c) Moving Customer Premises

See Part 2, Section 7 of this Guidebook, for rates and charges. (T)

(E) Installation and Rearrangement Charges

	Administrative Charge, per Order	Design and Central Office Connection Charge, per circuit	Customer Connection, Charge, per termination
USOC	ORCMX	NRMCK	NRBBL
OC-3/OC-3c	\$60.00	\$ 375.00	\$450.00
OC-12/OC-12c	60.00	375.00	450.00
OC-48/OC-48c	60.00	500.00	600.00
OC-192/OC-192c	60.00	2,250.00	600.00
Ethernet 100 Base	60.00		
Ethernet 1000 Base	60.00		