

30. OC-192 Dedicated SONET Ring Service

30.1 General Description

(A) Basic Service Description

OC-192 Dedicated SONET Ring Service is a 9.953 Gbps transport special access service. OC-192 is designed for transport of lower speed services, e.g. DS3, OC-3 or OC-3c, OC-12 or OC-12c, OC-48 or OC-48c and 1 Gbps Ethernet. The dedicated ring is designed to provide increased reliability and functionality by connecting multiple customer locations and specified Telephone Company Central offices via self-healing Rings. OC-192 is a logical extension of the existing SONET products OC-3, OC-3c, OC-12, OC-12c, OC-48 and OC-48c.

The dedicated ring can connect multiple (between 2 and 16) customer-designated locations and telephone company central offices, as described in Section 30.1(B)(1), where SONET facilities and equipment are available. Rate elements include nodes, ports, mileage, regenerators, and add/drop capability. Rates are specified in Section 30.4. (D)
(T)

Rates and charges for OC-192 Dedicated SONET Ring Service are set forth in Section 30.4, with the exception of the services provided by the Telephone Company in the Metropolitan Statistical Areas (MSAs) in which the Telephone Company has received Phase II pricing flexibility pursuant to Subpart H of Part 69 of the Commission's Rules. The rates and charges for the OC-192 Dedicated SONET Ring Service in the MSAs that have received Phase II pricing flexibility are set forth in Section 31. (D)

(B) Service Provisioning

(1) Manner of Provisioning

All customers will be served from the nearest suitably equipped end office. Information pertaining to end offices equipped to provide OC-192 Dedicated SONET Ring Service is set forth in the National Exchange Carrier Association, Inc. Tariff F.C.C. No. 4. OC-192 Dedicated SONET Ring Service will be provided subject to the availability and limitations of The Telephone Company's wire centers and outside plant facilities. OC-192 Dedicated SONET Ring Service is only available where technical capabilities permit such facility distance and type of physical plant. Where facilities are not available, Special Construction charges may apply.

(D)

(2) Limitations

The Telephone Company does not undertake to originate data, but offers the use of its OC-192 Dedicated SONET Ring Service, where available, to customers for the purpose of transporting data originated by the customer or a third party.

Unprotected services may be interrupted to repair other circuits. In cases where the customer orders OC-192 Dedicated SONET Ring Service with an unprotected 2-fiber service interface, the Telephone Company may provision this unprotected service, with other unprotected services, via a multi-port circuit card. If one unprotected service on the card incurs an outage, the Telephone Company may repair the 2-fiber service interface device by replacing the card, which may temporarily interrupt service on any other unprotected tributary circuits that subtend this same multi-port circuit card. In the event of a service interruption, credit allowance will be provided for the service that suffered the unplanned outage, as outlined in Section 30.1(3).

(D)

The Telephone Company will maintain and repair the OC-192 Dedicated SONET Ring Service which it furnishes and will provide the customer reasonable notification of service affecting activities that may occur in the normal operation of business.

(3) Allowance for Service Interruptions

Dedicated Rings provide Automatic Protection Switching to assure 100 percent availability of the services on the ring. A service interruption will result in a credit equal to one month's bill for the individual port-to-port connection involved. An interruption of service will start when an inoperative service is reported to the Telephone Company and end when the service is operative. In any month, as a result of an interruption, the total credit per rate element of the interrupted service may not exceed 100 percent of the monthly charge for that particular rate element.

In the event that protected facilities do not exist, including dual entrance facilities, and the customer does not utilize Special Construction to provide protected facilities, the unprotected OC-192 ring will be provided. In addition, the customer waives the right to receive credit allowances for service interruptions, and waives the SONET Assurance Warranty.

(C) Responsibility of The Telephone Company

The Telephone Company will provision and maintain OC-192 Dedicated SONET Ring Service for the customer up to and including the Network Interface (NI).

(D) Rights of The Telephone Company

The Telephone Company will not provision OC-192 Dedicated SONET Ring Service if it has reasonably determined that (a) it is not technically feasible over existing facilities or (b) it will cause interference problems within The Telephone Company's network or other facilities.

(E) Responsibility of Customer

The customer is responsible for providing compatible customer provided equipment (CPE) to be used for connection to OC-192 Dedicated SONET Ring Service.

30.2 Technical Specifications

Technical specifications for OC-192 Dedicated SONET Ring Service are listed in the following Telephone Company technical publications:

- (1) AM TR-TMO 000101 Ameritech Digital Service Transmission Parameters for Performance
- (2) AM TR-NIS-000111 Ameritech OC-3, OC-12, OC-48 and OC-192 Service Interface Specifications
- (3) TP 76839 SONET Transmission Requirements Performance and Interface Specification
- (4) TP 76412 SBC Customer Interface Standards for 100 Mbps and Higher Excluding SONET Interfaces

30.3 Rate Conditions

(A) Rate Elements

(1) Nodes

The ring will provide connectivity to multiple customer designated locations (nodes). However, a ring must have a minimum of two nodes. At least one node must be a Telephone Company Central Office (CO) node. A maximum of 16 nodes including regenerators will be allowed per ring. The Telephone Company reserves the right to determine the order of the nodes on the ring⁽¹⁾.

When a customer premise node is located in the same building as a CO node, diversity between the two nodes may not be available.

If a customer collocates two customer premise nodes of the same speed, on the same dedicated ring, on the same premises, the additional node will be billed as shown in Section 30.4. This option does not guarantee diversity between these two collocated nodes and the rest of the ring. (T)

The customer will be billed time and material as set forth in Part 2, Section 13 of this Guidebook, for any additional charges incurred by the Telephone Company in locating Telephone Company equipment at the customer premises.

(i) Re-Map Node⁽²⁾

A Re-Map node is a ring node that is pre-equipped and dedicated to customer traffic that is re-mapped/re-routed to it by the Telephone Company (upon notification by the customer of a service outage at another customer premises node on the same dedicated ring).

Re-Map is designed as a temporary service for disaster recovery purposes only. No "normal" customer traffic will be added/dropped at the Re-Map node unless the Re-Map service is activated.

⁽¹⁾ A ring node providing an OC-48 connection to a collocation cage can be considered a customer premise node.

⁽²⁾ Effective August 1, 2013, availability of Re-Map nodes is limited to Re-Map nodes that are in service or have been ordered prior to August 1, 2013.

(ii) Sub-Ring Node

A sub-ring node is a lower speed optical extension off a main ring. It traverses one or more main ring nodes via the use of OC-N port connections on and off the main ring. The primary use of sub-ring nodes is to provide the ability to fully utilize the bandwidth around the ring when the customer requires DS1/VT1.5 circuit paths.

An optional sub-ring node is available at OC-3, OC-12 and OC-48 speeds from an OC-192 main ring. A sub-ring node may only connect to the main ring at the same, or an adjacent, main ring node. A sub-ring node may not connect directly to another sub-ring node.⁽¹⁾

Any service that enters the main ring via a port on a sub-ring node must also exit via a port on another sub-ring node (sub-ring on - sub-ring off).⁽¹⁾ Cascading sub-rings are not allowed off a main ring. Service circuits may not be established between sub-ring nodes connecting to the same main ring node, or between a sub-ring node and a port on the same main ring node to which it connects.

Each sub-ring must be implemented as an OC-M on an OC-N ring with full complement of STS-1s, STS-3s or STS-12s, depending on the bandwidth of the sub-ring, appearing together at all associated sub-ring nodes on a given sub-ring.

Two OC-N ports and associated node charges apply for each sub-ring node connected to the main ring, as well as applicable mileage for the sub-ring.

A sub-ring node which is collocated with a main ring node at the customers premises (for the same dedicated ring) will be billed as an "Additional Node" as set forth in Section 30.4(A). A sub-ring is (T) not available with a two-node main ring configuration.

A sub-ring node is only available in the Uni-Directional Path Switched Ring (UPSR) mode.

⁽¹⁾ This restriction does not apply for Next Generation SONET equipment.

Sub-Ring Node Diagram

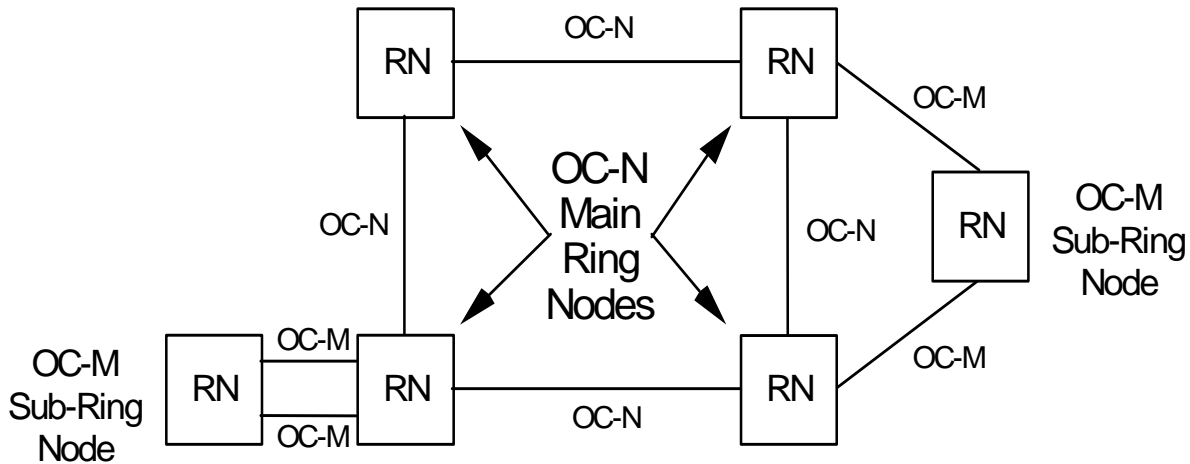

Sub-Ring Nodes, OC-M < OC-N

(iii) Arc Sub-Ring Node

Arc sub-ring nodes are only available on Next Generation SONET equipment with service installed after November 2, 2007. An Arc sub-ring node is a lower speed optical extension off a main ring. It connects to one main ring node via the use of OC-N port connections from and to a main ring. The primary use of Arc sub-ring nodes is to add other locations to the ring that will utilize minimal amounts of bandwidth from the main ring.

Arc sub-rings are only available off of UPSR main rings. Arc sub-rings are only available where facilities and/or operating conditions permit, as determined by the Telephone Company.

An optical Arc sub-ring node is available at OC-3, OC-12 and OC-48 speeds from an OC-192 main ring. An Arc sub-ring node may connect to the main ring at any main ring node.

Cascading Arc sub-rings are not permitted off a main ring. Service entering an Arc sub-ring node cannot drop from the directly connecting main ring node (haripinning).

More than one Arc sub-ring may be added to a main ring. Each Arc sub-ring must be implemented as an OC-M on an OC-N ring with a full compliment of STS-1s, 3s or 12s, depending on the bandwidth of the Arc sub-ring, appearing together at all associated Arc sub-ring nodes on a given Arc sub-ring.

Two OC-N ports apply for each Arc sub-ring connected to the main ring. A node charge applies for each Arc sub-ring location. Mileage charges are applicable when the sub-ring is in a different location than the main ring.

An Arc sub-ring node which is collocated in the same room with a main ring node at the customer's premises (for the same dedicated ring) will be billed as an "Additional Node."

Arc sub-rings do not reduce the bandwidth capacity of the main ring. As services are added to the main or sub-ring, only the bandwidth capacity of the service is reduced.

Arc sub-rings can be provisioned in two basic configurations:

1. Single-node, single-homed ARC
2. Multi-node, single-homed ARC

Circuit traffic can be added/dropped from an Arc sub-ring node to another Arc sub-ring node within the same Arc (known as intra-ARC), or between ARCs (known as inter-ARC). Intra-ARC circuits can only be provisioned as unprotected due to technical limitations. Circuit traffic can also originate on an Arc sub-ring node and route across and drop from a main ring node, but only when UPSR protection schemes are used.

ARC Sub-Ring Node Diagram

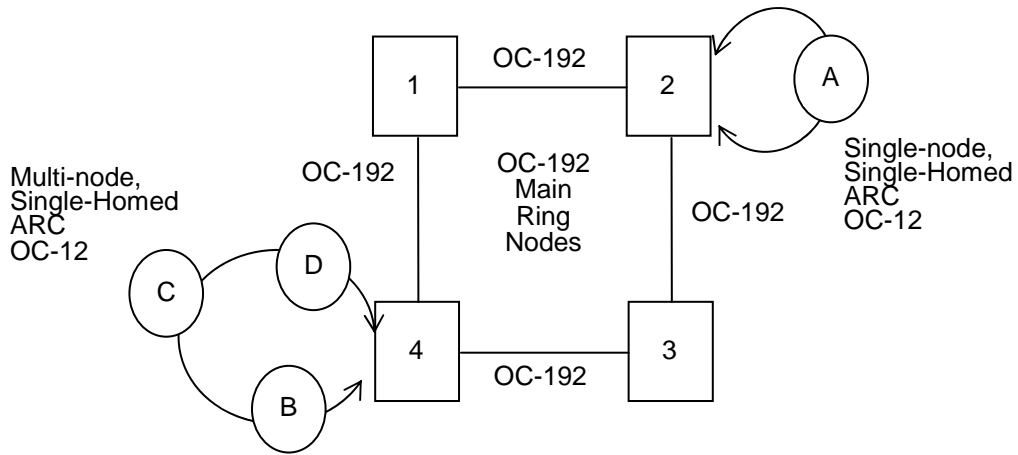

ARC Sub-Ring Nodes, OC-M < OC-N
OC-192 Dedicated Ring shown as example.

(2) Add/Drop Capability

This provides the capability to add/drop lower speed channels from an OC-192 Dedicated Ring node location via OC-48 or OC-12 ports. OC-192 Add/Drop Capability at an OC-192 Dedicated SONET Ring Service node location will support various combinations of service traffic not to exceed 192 STS-1 equivalents, contingent upon limitations of drop port capacity.

The OC-192 Add/Drop Capability charge is applied to all nodes, excluding regenerators and CO nodes without drop ports.

(3) Ports

Ports provide access to the ring and to lower speed channels (DS3, EC-1, OC-3, OC-3c, OC-12, OC-12c, OC-48, OC-48c, OC-192, 100 Mbps (STS-1) Ethernet, 100 Mbps (STS-3c) Ethernet, 1 Gbps (STS-1) Ethernet, 1 Gbps (STS-3c) Ethernet, 1 Gbps (STS-12c) Ethernet and 1 Gbps (STS-24c) Ethernet) between nodes. Lower speed channels are accessible at nodes via port terminations.

Ethernet over SONET (EoS) allows the efficient transport of Ethernet frames using SONET. Ethernet ports will be available in bandwidths up to the Ethernet interface of 1 Gbps on SONET Ring Services. As SONET bandwidths will be present, the customer will be unable to transmit data (including any bursts) beyond these preset SONET bandwidths. Interfaces of 1 Gbps Ethernet are available only to customers with Next Generation SONET equipment. Access into the Telephone Company's Ethernet ports must conform to industry standards and specifications as described in technical publication SBC-TP-76412-000. Only Single-Mode Fiber is available in the Central Office. The EoS line rates, defined in Section 30.4(C), are based on the theoretical SONET payload line rates as per GR-253-CORE, Issue 4. These values are not representative of the true Ethernet transport capacity of the EoS circuit.

(T)

Accepted interfaces are as follows:

	OC-192 Node
DS1 Ports	x (Max. 84/OC-3Port)
DS3 Ports	x (Max. 192/Node)
EC-1 Ports	x (Max. 192/Node)
OC-3, OC-3c Ports	x (Max. 64/Node)
OC-12, OC-12c Ports	x (Max. 16/Node)
OC-48, OC-48c Ports	x (Max. 4/Node)
OC-192 Ports ⁽¹⁾	x (Max. 1/Node)
100 Mbps (STS-1) Ethernet Port	x (Max. 192/Node)
100 Mbps (STS-3c) Ethernet Port	x (Max. 64/Node)
1 Gbps (STS-1) Ethernet Port	x (Max. 192/Node)
1 Gbps (STS-3c) Ethernet Port	x (Max. 64/Node)
1 Gbps (STS-12c) Ethernet Port	x (Max. 16/Node)
1 Gbps (STS-24c) Ethernet Port	x (Max. 8/Node)
10/100 BaseT Ethernet Port	
VT1.5-1v (1.6 Mbps)	X (Max. 84/OC-3)
VT1.5-2v (3.2 Mbps)	X (Max. 42/OC-3)
VT1.5-3v (4.8 Mbps)	X (Max. 28/OC-3)
VT1.5-4v (6.4 Mbps)	X (Max. 21/OC-3)
VT1.5-5v (8.0 Mbps)	X (Max. 16/OC-3)
VT1.5-6v (9.6 Mbps)	X (Max. 14/OC-3)
VT1.5-7v (11.2 Mbps)	X (Max. 12/OC-3)
VT1.5-8v (12.40 Mbps)	X (Max. 10/OC-3)
VT1.5-10v (16.0 Mbps)	X (Max. 8/OC-3)
VT1.5-13v (20.8 Mbps)	X (Max. 6/OC-3)
STS-1-1v (48.38 Mbps)	X (Max. 48/Node)
STS-1-2v (96.77 Mbps)	X (Max. 24/Node)
1000 BaseSX/LX Ethernet Port	
STS-1-1v (48.38 Mbps)	X (Max. 192/Node)
STS-1-2v (96.77 Mbps)	X (Max. 96/Node)
STS-1-3v (145.15 Mbps)	X (Max. 64/Node)
STS-1-4v (193.54 Mbps)	X (Max. 48/Node)
STS-1-5v (241.92 Mbps)	X (Max. 38/Node)
STS-1-6v (290.30 Mbps)	X (Max. 32/Node)
STS 1-9v (435.46 Mbps)	X (Max. 21/Node)
STS-1-12v (580.61 Mbps)	X (Max. 16/Node)
STS-1-21v (1016.06 Mbps)	X (Max. 9/Node)
STS-3c-1v (149.76 Mbps)	X (Max. 64/Node)
STS-3c-2v (299.52 Mbps)	X (Max. 32/Node)
STS-3c-3v (449.28 Mbps)	X (Max. 21/Node)
STS-3c-4v (599.04 Mbps)	X (Max. 16/Node)
STS-3c-7v (1048.32 Mbps)	X (Max. 9/Node)

⁽¹⁾ OC-192 and OC-192c ports support both OC-192 and OC-192c bandwidths.

OC-3, OC-3c, OC-12, OC-12c, OC-48, OC-48c and OC-192 ports may be ordered at CO nodes. Both are available for Service-to-Service through Connect with Optical Carrier Network Point-to-Point Service as set forth in Section 32. (D)

(4) Mileage

Mileage is charged as specified in Section 7. Fractions of a mile are rounded up to the whole mile for rate calculations. A one-mile minimum will be billed between nodes. A two-node ring configuration has a two-mile minimum, one mile from the wire center node to the customer premises node, and one mile from the customer premises node to the wire center node. (D)

(5) Ring Regenerator

Regenerators provide essential detection and retransmission of the SONET Optical 9.953 Gbps signal between nodes. Regenerators will only be provided as required by the Telephone Company when actual fiber facility distances between nodes exceed inter-nodal design limits. Regenerators will be located exclusively in Telephone Company COs and do not allow ports to access customer service connections.

(6) Electrical Connection - Level 1 (EC-1)

EC-1 is an electrical interface that can transport up to 51.84 Mb of bandwidth in a concatenated format. The EC-1 port is available on an OC-3, OC-12, OC-48 and OC-192 ring. For the above connection capacity charts, the quantity of EC-1 ports is equivalent to the connection capacity of a DS-3.

(D)
(D)

(B) Dedicated Ring Connection Capacity

Maximum transport capacity of OC-192 Dedicated Ring Service is characterized by the total quantity of individual port-to-port connections allowed between all nodes on the ring.

For OC-192 Dedicated SONET Ring Service, the maximum ring capacity between adjacent nodes is not to exceed 96 STS-1 equivalents.

OC-192 Dedicated SONET Ring Service will provide capability for node-to-node connection of STS-1 or STS-3C channels using OC-3, OC-3c, OC-12, OC-12c, OC-48, OC-48c, 100 Mbps Ethernet or 1 Gbps Ethernet ports on the OC-192 ring.

OC-192 Dedicated SONET Ring Service will provide capability for node-to-node connections of STS-12C channels using OC-12, OC-12c, OC-48, OC-48c or 1 Gbps Ethernet ports on the OC-192 ring.

OC-192 Dedicated SONET Ring Service will provide capability for node-to-node connections of STS-48C channels using OC-48 or OC-48c ports on the OC-192 ring.

Virtual Concatenation (VCAT) provides the ability and flexibility to size the customer's bandwidth, sub-rate VT1.5 and super-rate STS-1 and 3c service payloads, based on their traffic requirements. For transport of payloads that do not fit efficiently into the standard set of VT1.5, STS-Nc payload envelopes, virtual concatenation can be used.

The maximum transport capacity of an OC-3, OC-12 or OC-48 sub-ring or Arc sub-ring is characterized by the total quantity of individual port connections allowed between all nodes on the ring. Refer to DSRS Section 29.3(A)(7) for combinations.

(C) Term Pricing Plan⁽¹⁾

(1) General Description

OC-192 Dedicated Rings are available for either three or five year Term Pricing Plan (TPP) periods. Monthly recurring charges apply for the nodes, ports and mileage.

(2) Nonrecurring Charges

Nonrecurring Charges, including the Administrative Charge as Set forth in Section 30.4, will apply for those arrangements ordered under the OC-192 Ring TPP. The Access Order Charge does not apply.

(3) Rate Flow Through

Any decreases in recurring rates will be passed on to customers who participate in the TPP. The Telephone Company will notify customers participating in the TPP when monthly rates are decreased.

Should the Telephone Company increase its rates during the TPP period, the customer will pay the increased rates as long as the increase does not exceed the original rate in effect at the time the customer established service under the TPP.

(4) Adding Nodes to the Ring

If a node is added after the initial installation of the dedicated ring, the new node will carry the same TPP rate as the initial ring and be co-terminus with that TPP. However, if a node is added during the last 12 months of a TPP, the customer will be billed the initial node rate for a minimum period of 12 months. All applicable Nonrecurring Charges as set forth in Section 30.4 will apply.

(5) TPP Renegotiation

The customer may choose to terminate an existing TPP at any time prior to the end of the three or five year period and negotiate a new TPP without termination liability provided the new TPP meets the following requirements:

- (a) The minimum period for the new TPP must be greater than the remaining period currently in effect and
- (b) The renegotiated TPP will be based on the current rates.

⁽¹⁾ All term plans for OC-192 Dedicated SONET Ring Service which are established or renewed after November 9, 2013, for term lengths which are scheduled to expire at any time after February 1, 2019, will instead expire on February 1, 2019. All such services existing on or after February 1, 2019, will be provided on a month-to-month basis at the applicable, then current month-to-month rates. Notwithstanding anything to the contrary in the previous two sentences, this footnote does not apply to any term plans established or renewed after July 15, 2017.

(N)
(N)
(N)

When the customer converts to a new TPP, actual time in service for the original TPP will be applied. However, no credits or refunds will apply for the billing of actual time in service for the previous TPP.

(6) Renewal

The customer must provide the Telephone Company with a written notice of intent to renew a TPP no later than 60 days prior to its expiration.

The customer will continue to be billed at the current TPP rates.

If the customer does not renew the TPP, or does not notify the Telephone Company of its intent to renew the TPP, the customer's service will convert to the Monthly Extension rate as set forth in Section 30.4 until the customer cancels (T) or renews the service with a new TPP term. Monthly Extension Rates are not available to new subscriptions.

(7) Termination of Service

If a customer cancels a service order or terminates services before the completion of the term for any reason whatsoever other than a service interruption, the customer agrees to pay to the Telephone Company termination liability charges, which are defined below. These charges shall become due and owing as of the effective date of the cancellation or termination and are payable within 30 days of the invoice date, subject to interest penalty on the unpaid balance.

Customer's termination liability for cancellation of service shall be equal to:

- (a) all waived and/or unpaid nonrecurring charges, plus;
- (b) 50% of all recurring charges for the balance of the customer's team.

(D) Moves

(1) Moves within a Customer's Premises

A move involves a change in the physical location of the Point of Termination on the customer's premises. Such moves will be treated as an extension of OC-192 Ring facilities. Extension of OC-192 Ring facilities will be provided, at the customer's request, on a time-sensitive charge basis. The labor rates that apply are set forth in Part 2, Section 13 of this Guidebook. There will be no change in the TPP term requirements. (D)

(2) Moves of OC-192 Dedicated Ring Nodes

Moves of OC-192 Ring nodes will be provided, at the customer's request, on a time-sensitive charge basis. The charge will not exceed the Nonrecurring Charge for subsequent installation, as specified in Section 30.4(A), for the specific OC-192 Ring node being modified. The labor rates that apply are set forth in Part 2, Section 13. Where facilities are not available, Special Construction charges may apply. No change in billing period is required. Termination charges will not apply to moves of OC-192 Ring nodes. (D)

(E) Upgrade to OC-192 Dedicated SONET Ring Service from lower speed Services⁽¹⁾

Customers with three or five year Rate Stability Payment Plans (RSPP) may at any time upgrade from OC-48 to OC-192 Dedicated SONET Ring Service without incurring the Termination Liability charge, providing the following criteria are met:

- The customer subscribes to a Term Pricing Plan period that is equal to, or greater than 36 months;
- The expiration date for the new Term Pricing Plan period is beyond the end of the original RSPP period;
- No lapse in service occurs;
- Nonrecurring Charges will apply, when applicable;
- The monthly rates for the new service(s) will be those rates in effect at the time the new service(s) is/are installed;
- The new service is provided between the same customer locations and with the same customer of record as the disconnected service;
- The original location of all nodes must be included in the new service.
- Billed recurring revenue for each month of the first eighteen months of the new service is equal to or greater than the billed recurring revenue for the last month of the service(s) being converted;
- Customer agrees not to convert the new service term pricing plan to a pricing plan with a lower rate for the period of eighteen months after the conversion; and
- Spare facilities and equipment must be available or a nonrecurring upfront payment, which is a Special Construction Charge, may apply.

(F) Migration onto OC-192 Dedicated SONET Ring Service

Billing for the OC-192 Dedicated SONET Ring service will commence upon service order completion for all rate elements. Billing for the existing OC-48 Ring service will continue until the migration of all circuit services on to the new OC-192 Ring is complete at which time the OC-48 Ring service may be disconnected.

⁽¹⁾ All term plans for OC-192 Dedicated SONET Ring Service which are established or renewed after November 9, 2013, for term lengths which are scheduled to expire at any time after February 1, 2019, will instead expire on February 1, 2019. All such services existing on or after February 1, 2019, will be provided on a month-to-month basis at the applicable, then current month-to-month rates. Notwithstanding anything to the contrary in the previous two sentences, this footnote does not apply to any term plans established or renewed after July 15, 2017.

(N)
(N)
(N)

(G) Shared Network Arrangement⁽¹⁾

Shared Network Arrangement is a service offering that enables a customer ("Service User") to connect subtending services to an OC-192 Dedicated SONET Ring service of another customer (the "Host Subscriber"), with the Telephone Company maintaining separate billing for each. Each customer will be billed for those rate elements associated with their own portion of the service configuration. The Host Subscriber will be responsible for all OC-192 Dedicated SONET Ring Service rate elements, for example, node, ports and mileage, etc. Under no circumstances will the rates or charges for individual rate elements be split.

This offering is limited to service configurations where a Service User orders a subtending service dropped from a Host Subscriber's OC-192 Ring wire center node. Under Shared Network Arrangement, the Telephone Company may share record information with the Host Subscriber pertaining to the services of other users of the shared network. Such disclosure will be under the sole discretion of the Telephone Company and is necessary to perform billing reconciliation and/or other functions required in connection with maintaining account records.

(H) Shared Use

Shared Use occurs when Switched Access and Special Access services are provided over the same analog or digital high capacity facility or SONET based service through a common interface. The conditions governing the provision of Shared Use are set forth in 5.2.10 and 6.7.15 of Tariff F.C.C. No. 1.

While Shared Use of SONET facilities (i.e., OC-192 Dedicated SONET Ring Service) for Switched Access Transport is permitted, the SONET Special Access facilities continue to be rated as Special Access.

(1) Effective 05/26/06, this condition is limited to existing customers. For new customers purchasing Shared Network Arrangement, terms and conditions set forth in Part 2, Section 5 of this Guidebook, will apply. (T)

(I) Optical-to-Electrical Add/Drop Capability⁽¹⁾

1. The Optical-to-Electrical DS-1 Add/Drop Capability allows an electrical DS-1 to be derived from an optical OC-192 ring by using this capability to add/drop the electrical DS-1 from an OC-3 port.

Effective 06/10/06, Optical-to-Electrical DS-1 Add/Drop Capability will be available from an optical OC-192 shelf.

The Optical-to-Electrical DS-1 Add/Drop Capability charge is applied when the 29th DS-1 port is required per OC-192 node. Additional charges will apply per each subsequent increment of 84 DS-1 ports.

2. The Optical-to-Electrical DS-3 Add/Drop Capability allows an electrical DS3 to be derived from an optical OC-3, OC-12 or OC-48 shelf. The manner in which a DS3 is dropped will be designed based on forecast and equipment hierarchy.

For OC-192 SONET Rings established prior to 03/24/05, when electrical drops are required, the Optical-to-Electrical DS-3 Add/Drop Capability charge is applied in addition to the Add/Drop Capability charge as described in section 30.3(A)(2).

For OC-192 SONET Rings established after 03/24/05, the Optical-to-Electrical DS-3 Add/Drop Capability charge is applied only once and only when the 25th DS-3 port is applied per node.

(J) Ethernet Over SONET

Effective January 21, 2004, new orders for OC-192 Dedicated SONET Ring Service with the EoS enhancement will be served by different equipment than the equipment used for customers who placed Dedicated SONET Ring Service orders that were completed prior to January 21, 2004. Customers subscribing to OC-192 Dedicated SONET Ring Service prior to January 21, 2004 requesting a change to the new equipment will incur termination liability charges for their existing service. Disconnect of the existing OC-192 Dedicated SONET Ring Service and placement of an order for new OC-192 Dedicated SONET Ring Service with the EoS enhancement is required. The monthly rates for the new service(s) shall be those rates in effect at the time the new service(s) is installed.

(1) For OC-192 SONET Rings, the OC-192 Add/Drop Capability charge is applied to all nodes, excluding regenerators and CO nodes without drop ports.

(K) Re-Map Service⁽¹⁾

(N)

Re-Map Service is provided in conjunction with Dedicated SONET Ring Service and allows for a pre-defined set of services to be re-routed by the Telephone Company from one customer premises node to another customer premises node (defined as a "Re-Map node") in the event of a customer premises disaster. Re-Map service will be tested at initial installation and once each year thereafter. Additional testing can be requested and will be charged on a per test basis. Activation upon customer request in the event of an emergency will be charged on a per occurrence basis.

Once the customer notifies the Telephone Company that they are ready to receive signals to the Re-Map node site, the Telephone Company will Re-Map up to 50 circuits within the initial hours and 20 circuits every hour thereafter. The Emergency Activation Nonrecurring Charge will not be applied if the first 50 circuits are not Re-Mapped within 4 hours due to a Telephone Company-caused delay.

Re-Map testing and activation for OC-192 service requires a minimum of one DS1 (VT1.5), or 1 DS3 (STS-1) between one customer premises node and the Re-Map node. Re-Map testing or activation for OC-12 or OC-48 service requires a minimum incremental group from 1 to 28 DS1s or one DS3 (equals one STS-1) between one customer premises node and the Re-Map node.

The emergency Re-Map activation configuration will be maintained for up to 30 days. After 30 days, if the customer wishes to maintain the emergency configuration, the Emergency Activation Nonrecurring Charge will be applied once for each 30 day additional period.

Re-Map Service is available on Self-Healing Uni-Directional Path Switched Rings (UPSR) only.

(L) STS-1 Service

The STS-1 circuit allows the efficient transport of up to 51.84 Mbps of bandwidth across Dedicated SONET Ring utilizing EC-1 (Electrical Connection - Level 1) ports on the dedicated service. While the EC-1 port is comparable to the DS-3 port as far as the connection capacity per STS, the STS-1 circuit utilizes the entire bandwidth of the STS (51.84 Mbps) while the DS-3 uses 44.76 Mbps of the STS. The STS-1 circuit is available via EC-1 ports on an OC-192 ring.

⁽¹⁾ Effective August 1, 2013, availability of Re-Map nodes is limited to Re-Map nodes that are in service or have been ordered prior to August 1, 2013. (N)

(M) Unprotected Channel Transport (UCT)

UCT will allow customers to transport traffic (DS-1, DS-3, up to OC-48), over a ring without enabling SONET protection schemes. This is intended for applications in which the customer provides protection for the circuit through means other than those available through SONET. If a fault occurs on the ring along the transport path, the traffic will not be switched to a protection channel. Service will be interrupted on that circuit until the fault is corrected. The customer is required to call in and open a trouble ticket for the unprotected service. If a fault occurs in the ring, but does not occur along the transport route, service will not be interrupted on that circuit.

Customers who order Dedicated SONET Ring Service may need to replace or upgrade their existing service to invoke use of UCT for circuit assignments. Use of UCT is managed through a Special Routing Code (SRC) in relation to a circuit's Connecting Facility Assignment (CFA). When an Unprotected service is placed on a channel, the protection switching is shut off. When a UCT is disconnected, the channel will revert back to the standard protection mode.

(N) Jointly Provided Service

(N)

(1) General

OC-192 Dedicated SONET Ring Service may be available in a meet-point billing arrangement involving another Incumbent Local Exchange Carrier (ILEC) (sometimes also referred to as an Independent Company or ICO), where suitable facilities exist and where appropriate procedures for such arrangement have been put in place between the Telephone Company and the other ILEC. When the Telephone Company and another ILEC jointly provide a meet-point ring arrangement, each ILEC involved shall provision and bill the portion of service located in its operating territory according to the terms and conditions of that ILEC's applicable tariffs or other service publications.

(2) Ordering

The Customer shall order OC-192 Dedicated SONET Ring Service by issuing an access order, or by such other means for the exchange telephone companies to provision on the ring in each exchange telephone company territory. The Customer will place the order for service as set forth in the ordering conditions for the requested service.

(3) Credit Allowance for Service Interruption

OC-192 Dedicated SONET Ring Service, provided in a meet-point arrangement, is subject to the general terms and conditions in Part 2, Section 2, including, without limitation, the exclusions applicable to Credit Allowances for Service Interruptions, as provided in Part 2, Section 2.5.6(F). As clarification, but not to modify any such terms and conditions, a Credit Allowance for Service Interruptions shall not apply to any service interruption resulting from any failure attributable to the other ILEC jointly providing the service or otherwise not attributable to the Telephone Company.

(N)

30.4 Rates and Charges

(A) Nodes

Description	USOC	3 year ⁽⁴⁾	5 Year ⁽⁴⁾	Monthly Extension
- Customer Premises				
First	GP5AX/GP5++	\$19,800.00	\$14,400.00	\$33,000.00
First Re-Map ⁽³⁾	RNFAX	19,800.00	16,000.00	33,000.00
Additional	GP5AA/GP5++	17,800.00	13,000.00	29,475.00
Additional Re-Map ⁽³⁾	RNFAX	17,800.00	14,200.00	29,475.00
- Central Office	GC5AX/GP5++	17,800.00	13,000.00	29,475.00

Description	USOC	Nonrecurring Charge
Nonrecurring charges for subsequent installation		
- Per Node		
Customer Premises	NRBS7	\$400.00
Customer Premises Re-Map ⁽³⁾	NRBS7	400.00
Central Office	NRBSV	325.00

(B) Add/Drop Capability

Description	USOC	3 year ⁽⁴⁾	5 Year ⁽⁴⁾	Monthly Extension
Per Arrangement	MXRGX/MXR++	\$4,500.00	\$3,240.00	\$7,000.00
- (per node) ⁽¹⁾ not to exceed any configurable combination of ports beyond 192 STS-1 equivalents				
- Re-Map ^{(2) (3)}	M8RGX	\$4,500.00	\$3,600.00	\$7,000.00

(C) Ports

Description	USOC	3 year ⁽⁴⁾	5 Year ⁽⁴⁾	Monthly Extension
- Per Port				
DS1	S9QWX	50.00	45.00	65.00
DS3	S9QGX/S9Q+	120.00	110.00	150.00
DS3 w/Transmux ⁽²⁾	S4NGX	250.00	200.00	300.00
EC-1	S9TZX	120.00	110.00	150.00
OC-3,OC-3c	S9NEX/S9N+	135.00	120.00	225.00
OC-12,OC-12c	S9NGX/S9N+	325.00	300.00	550.00
OC-48,OC-48c	S9NJX/S9N+	825.00	760.00	1425.00
OC-192	+	3300.00	3000.00	5700.00
100 Mbps Ethernet (STS-1) at OC-192	S9T4X S9TNX	145.00	130.00	225.00
100 Mbps Ethernet (STS-3c) at OC-192	S9TOX	180.00	160.00	280.00
1 Gbps Ethernet (STS-1) at OC-192	S9TPX	250.00	200.00	350.00
1 Gbps Ethernet (STS-3c) at OC-192 node*	S9TQX	250.00	200.00	350.00
1 Gbps Ethernet (STS-12c) at OC-192 node*	S9TRX	600.00	500.00	875.00
1 Gbps Ethernet (STS-24c) at OC-192 node*	S9TSX	900.00	850.00	1500.00

(1) The OC192 Add/Drop Capability charge is applied to all nodes, excluding regenerators and CO nodes without drop ports.

(2) Available for rings established on or after 10/17/06.

(3) Effective August 1, 2013, availability of Re-Map nodes is limited to Re-Map nodes that are in service or have been ordered prior to August 1, 2013.

(4) All term plans for OC-192 Dedicated SONET Ring Service which are established or renewed after November 9, 2013, for term lengths which are scheduled to expire at any time after February 1, 2019, will instead expire on February 1, 2019. All such services existing on or after February 1, 2019, will be provided on a month-to-month basis at the applicable, then current month-to-month rates. Notwithstanding anything to the contrary in the previous two sentences, this footnote does not apply to any term plans established or renewed after July 15, 2017.

(N)
(N)
(N)

Description	USOC	3 year ⁽⁶⁾	5 Year ⁽⁶⁾	Monthly Extension
EoS Ports Virtual Concatenation (VCAT) ⁽¹⁾ - per multiplexing function				
10/100 BaseT Ethernet Port	S5P1X	250.00	180.00	350.00
Bandwidth options for port ^{(2) (4) (5)}				
VT1.5-1v (1.6 Mbps)				
VT1.5-2v (3.2 Mbps)				
VT1.5-3v (4.8 Mbps)				
VT1.5-4v (6.4 Mbps)				
VT1.5-5v (8.0 Mbps)				
VT1.5-6v (9.6 Mbps)				
VT1.5-7v (11.2 Mbps)				
VT1.5-8v (12.4 Mbps)				
VT1.5-10v (16.0 Mbps)				
VT1.5-13v (20.8 Mbps)				
STS-1-1v (48.38 Mbps)				
STS-1-2v (96.77 Mbps)				
1000 Base SX Ethernet Port	S5P2X	425.00	350.00	500.00
1000 Base LX Ethernet Port	S5P3X	425.00	350.00	500.00
Bandwidth options for port ^{(3) (4) (5)}				
STS-1-1v (48.38 Mbps)				
STS-1-2v (96.77 Mbps)				
STS-1-3v (145.15 Mbps)				
STS-1-4v (193.54 Mbps)				
STS-1-5v (241.92 Mbps)				
STS-1-6v (290.30 Mbps)				
STS-1-9v (435.46 Mbps)				
STS-1-12v (580.61 Mbps)				
STS-1-21v (1016.06 Mbps)				
STS-3c-1v (149.76 Mbps)				
STS-3c-2v (299.52 Mbps)				
STS-3c-3v (449.28 Mbps)				
STS-3c-4v (599.04 Mbps)				
STS-3c-7v (1048.32 Mbps)				

⁽¹⁾ Nonrecurring charges apply to EoS Ports, Virtual Concatenation (VCAT). See EoS Port charges in Section 30.4 (C), for applicable nonrecurring charges.

⁽²⁾ Actual payload capacity for selected bandwidth.

⁽³⁾ Actual Payload capacity for selected bandwidth applies to both SX and LX.

⁽⁴⁾ Only Single-Mode Fiber is available in the Central Office.

⁽⁵⁾ The EoS line rates defined herein are based on the theoretical SONET payload line rates per GR-253-CORE, Issue 4. These values are not representative of the true Ethernet transport capacity of the EoS circuit.

⁽⁶⁾ All term plans for OC-192 Dedicated SONET Ring Service which are established or renewed after November 9, 2013, for term lengths which are scheduled to expire at any time after February 1, 2019, will instead expire on February 1, 2019. All such services existing on or after February 1, 2019, will be provided on a month-to-month basis at the applicable, then current month-to-month rates. Notwithstanding anything to the contrary in the previous two sentences, this footnote does not apply to any term plans established or renewed after July 15, 2017.

(N)
(N)
(N)

Description	USOC	36 Months ⁽³⁾	60 Months ⁽³⁾	Monthly Extension
- Per port (Re-Map) ⁽²⁾				
Per DS1 Re-Map Block (consists of 28 DS1 ports) at OC-192 Ring	RN76X	\$1400.00	\$1260.00	\$1820.00
Per DS3 Re-Map Block (consists of 3 DS3 ports at OC-192 Ring	RN77X	360.00	330.00	400.00
Per DS3 Re-Map Port at OC-192 Ring	RN71X	120.00	110.00	150.00
Per DS3 Transmux Re-Map ⁽¹⁾	RN7TX	200.00	200.00	300.00
Per EC-1 Re-Map Port at OC-192 Ring	S4NMX	120.00	110.00	150.00
Per OC-3 Re-Map Port at OC-192 Ring	RN72X	150.00	135.00	190.00
Per OC-12 Re-Map Port at OC-192 Ring	RN73X	375.00	360.00	475.00
Per OC-48 Re-Map Port at OC-192 Ring	RN74X	825.00	700.00	1425.00

Description	USOC	Nonrecurring Charge
Nonrecurring charges for subsequent installation		
- Per port type		
DS1	NRBSY	\$350.00
DS-3	NRBSX	385.00
DS3 w/Transmux ⁽¹⁾	NRBSX	385.00
EC-1	NRBSX	385.00
OC-3,OC-3c	NRBSW	400.00
OC-12,OC-12c	NRBSZ	400.00
OC-48,OC-48c	NRBN9	425.00
OC-192	NRBN2	750.00
100 Mbps Ethernet (STS-1) at OC-192 node	NRM63	385.00
100 Mbps Ethernet (STS-3c) at OC-192 node	NRM64	385.00
1 Gbps Ethernet (STS-1) at OC-192 node	NRM65	425.00
1 Gbps Ethernet (STS-3c) at OC-192 node*	NRM66	425.00
1 Gbps Ethernet (STS-12c) at OC-192 node*	NRM67	425.00
1 Gbps Ethernet (STS-24c) at OC-192 node*	NRM68	425.00
10/100 BaseT Ethernet Port	NRM63	385.00
1000 BaseLX Ethernet Port	NRM65	425.00
1000 BaseSX Ethernet Port	NRM66	425.00

⁽¹⁾ Available for rings established on or after 10/17/06.

⁽²⁾ Effective August 1, 2013, availability of Re-Map nodes is limited to Re-Map nodes that are in service or have been ordered prior to August 1, 2013.

⁽³⁾ All term plans for OC-192 Dedicated SONET Ring Service which are established or renewed after November 9, 2013, for term lengths which are scheduled to expire at any time after February 1, 2019, will instead expire on February 1, 2019. All such services existing on or after February 1, 2019, will be provided on a month-to-month basis at the applicable, then current month-to-month rates. Notwithstanding anything to the contrary in the previous two sentences, this footnote does not apply to any term plans established or renewed after July 15, 2017.

(N)
(N)
(N)

(D) Mileage

Description	USOC	3 Year ⁽³⁾	5 Year ⁽³⁾	Monthly Extension
Per mile between nodes ⁽²⁾	1YAZX/IYA++	\$260.00	\$210.00	\$330.00

(E) Ring Regenerator

	USOC	3 Year ⁽³⁾	5 Year ⁽³⁾	Monthly Extension
Each (as required)	RGY/RGY++	\$9,250.00	\$7,000.00	\$13,875.00

Description	USOC	Nonrecurring Charge
Nonrecurring charges for subsequent installation of Regenerator - Each (as required)	NRBS5	\$270.00

(F) Shared Network Arrangement

Description	USOC	Nonrecurring Charge
Processing Charge Per Service Order	NRMCL	\$30.00

(G) Installation and Administrative Charges

Description	USOC	Nonrecurring Charge
STS-1 Service	ORCMX	\$60.00
Administrative Charge per Service Order	ORCMX	60.00
Design and Central Office Connection Charge, per Initial Ring	NRMCK	2,250.00 ⁽¹⁾

⁽¹⁾ Per Ring Charge for Dedicated Ring Service is applied once per original ring installed.

⁽²⁾ A two-node ring configuration has a two-mile minimum, one mile from the CO node to the customer premise node, and one mile from the customer premise node to the CO node.

⁽³⁾ All term plans for OC-192 Dedicated SONET Ring Service which are established or renewed after November 9, 2013, for term lengths which are scheduled to expire at any time after February 1, 2019, will instead expire on February 1, 2019. All such services existing on or after February 1, 2019, will be provided on a month-to-month basis at the applicable, then current month-to-month rates. Notwithstanding anything to the contrary in the previous two sentences, this footnote does not apply to any term plans established or renewed after July 15, 2017.

(N)
(N)
(N)

Description	USOC	Nonrecurring Charge
Re-Map Service ⁽⁴⁾		
Initial Service Script Establishment/ Test Charge	NRMR1	\$5,500.00
Subsequent Script Activity Charge	NRMR3	3,200.00
Scheduled Test Charge	NRMR5	4,200.00
Emergency Re-Map Activation ⁽⁴⁾ (per request)	NRMR7	5,000.00

(H) Optical-to-Electrical Add/Drop Capability

Description	USOC	36 Months ⁽⁵⁾	60 Months ⁽⁵⁾	Monthly Extension
Per Arrangement ⁽¹⁾ - (per node) not to exceed any configurable combination of ports beyond 192 STS-1 equivalents	MXJGX/MXJG+	\$2,500.00	\$2,000.00	\$3,500.00
- Re-Map ^{(2) (4)} Per Optical to Electrical DS-3 Add/Drop Capability	M6JGX	\$2,500.00	\$2,000.00	\$3,500.00
Per OC-3 to DS-1 Add/Drop ⁽³⁾	MXJDX	875.00	700.00	1,050.00
Re-Map ⁽⁴⁾ Per OC-3 to DS-1 Add/Drop ⁽³⁾	M8RDX	875.00	700.00	1,050.00

Description	USOC	Nonrecurring Charge
Subsequent Installation Per OC-3 to DS-1 Add/Drop	NRBS6	\$490.00
Subsequent Installation Optical/Electrical of DS3 Add/Drop	NRBS8	490.00

⁽¹⁾ When electrical drops are required, the Optical-to-Electrical Add/Drop Capability charge is applied in addition to the Add/Drop Capability charge set forth in Section 30.4(B).

⁽²⁾ Available for rings established on or after 10/17/06.

⁽³⁾ An OC-3 port charge is needed with each Optical-to-Electrical Add/Drop Capability - Per OC-3 to DS-1 Add/Drop.

⁽⁴⁾ Effective August 1, 2013, availability of Re-Map nodes is limited to Re-Map nodes that are in service or have been ordered prior to August 1, 2013.

⁽⁵⁾ All term plans for OC-192 Dedicated SONET Ring Service which are established or renewed after November 9, 2013, for term lengths which are scheduled to expire at any time after February 1, 2019, will instead expire on February 1, 2019. All such services existing on or after February 1, 2019, will be provided on a month-to-month basis at the applicable, then current month-to-month rates. Notwithstanding anything to the contrary in the previous two sentences, this footnote does not apply to any term plans established or renewed after July 15, 2017.

(N)
(N)
(N)