

ISSUED: JUNE 16, 2011

EFFECTIVE: JULY 1, 2011

ACCESS SERVICE

2 - General Regulations

2.1 Undertaking of the Telephone Company

2.1.1 Scope

- (A) The Telephone Company does not undertake to transmit messages under this tariff.
- (B) The Telephone Company shall be responsible only for the installation, operation and maintenance of the service it provides.
- (C) The Telephone Company will, for maintenance purposes, test its services only to the extent necessary to detect and/or clear troubles.
- (D) Services are provided 24 hours daily, seven days per week, except as set forth in other applicable sections of this tariff.
- (E) The Telephone Company does not warrant that its facilities and services meet standards other than those set forth in this tariff.

2.1.2 Limitations

- (A) The customer may not assign or transfer the use of services provided under this tariff, except as provided herein. Where there is no interruption of use or relocation of the services, such assignment or transfer may be made for all services, to:
 - (1) Another customer whether an individual, partnership, association or corporation, provided the assignee or transferee assumes all outstanding indebtedness for such services, and the unexpired portion of the minimum period and the termination liability applicable to such services, if any; or
 - (2) A court-appointed receiver, trustee or other person acting pursuant to law in bankruptcy, receivership, reorganization, insolvency, liquidation or other similar proceedings, provided the assignee or transferee assumes the unexpired portion of the minimum period and the termination liability applicable to such services, if any.

ISSUED: JUNE 16, 2011

EFFECTIVE: JULY 1, 2011

ACCESS SERVICE

2 - General Regulations (Cont'd)

2.1 Undertaking of the Telephone Company (Cont'd)

2.1.2 Limitations (Cont'd)

(A) (Cont'd)

(2) (Cont'd)

In all cases of assignment or transfer, the written acknowledgment of the Telephone Company is required prior to such assignment or transfer. Such acknowledgment shall be made within 15 days from the receipt of notification. All regulations and conditions contained in this tariff shall apply to such assignee or transferee.

The assignment or transfer of services does not relieve or discharge the assignor or transferor from remaining jointly or severally liable with the assignee or transferee for any obligations existing at the time of the assignment or transfer.

- (B) The use and restoration of services shall be in accordance with Part 64, Subpart D, and Part 64, Appendix A, of the Federal Communications Commission's Rules and Regulations, which specifies the priority system for such activities.
- (C) Subject to compliance with the rules mentioned in (B) preceding, the services offered herein will be provided to customers on a first-come, first-served basis.

2.1.3 Liability

The following liability provisions apply for all services except BellSouth Virtual Expanded Interconnection Service. Liability provisions for BellSouth Virtual Expanded Interconnection arrangements are contained in 20.26 following.

- (A) The Telephone Company's liability, if any, for its willful misconduct is not limited by this tariff. With respect to any other claim or suit, by a customer, or by any others, for damages associated with the installation, provision, preemption, termination, maintenance, repair or restoration of service, and subject to the provisions of (B) through (H) following, the Telephone Company's liability shall not exceed an amount equal to the proportionate charge for the service for the period during which the service was affected. This liability for damages shall be in addition to any amounts that may otherwise be due the customer under this tariff as a Credit Allowance for a Service Interruption.

ISSUED: JUNE 16, 2011

EFFECTIVE: JULY 1, 2011

ACCESS SERVICE

2 - General Regulations (Cont'd)

2.1 Undertaking of the Telephone Company (Cont'd)

2.1.3 Liability (Cont'd)

- (B) The Telephone Company shall not be liable for any act or omission of any other carrier or customer providing a portion of a service, nor shall the Telephone Company for its own act or omission hold liable any other carrier or customer providing a portion of a service.
- (C) The Telephone Company is not liable for damages to the customer premises resulting from the furnishing of a service, including the installation and removal of equipment and associated wiring, unless the damage is caused by the Telephone Company's negligence.
- (D) The Telephone Company shall be indemnified, defended and held harmless by the end user against any claim, loss or damage arising from the end user's use of services offered under this tariff, involving:
 - (1) Claims for libel, slander, invasion of privacy, or infringement of copyright arising from the end user's own communications;
 - (2) Claims for patent infringement arising from the end user's acts combining or using the service furnished by the Telephone Company in connection with facilities or equipment furnished by the end user or IC or;
 - (3) All other claims arising out of any act or omission of the end user in the course of using services provided pursuant to this tariff.
- (E) The Telephone Company shall be indemnified, defended and held harmless by the IC against any claim, loss or damage arising from the IC's use of services offered under this tariff, involving:
 - (1) Claims for libel, slander, invasion of privacy, or infringement of copyright arising from the IC's own communications;
 - (2) Claims for patent infringement arising from the IC's acts combining or using the service furnished by the Telephone Company in connection with facilities or equipment furnished by the end user or IC or;

ISSUED: JULY 17, 2019

EFFECTIVE: JULY 18, 2019

ACCESS SERVICE

2 - General Regulations (Cont'd)

2.1 Undertaking of the Telephone Company (Cont'd)

2.1.3 Liability (Cont'd)

(E) (Cont'd)

(3) All other claims arising out of an act or omission of the IC in the course of using services provided pursuant to this tariff.

(F) The Telephone Company does not guarantee or make any warranty with respect to its services when used in an explosive atmosphere. The Telephone Company shall be indemnified, defended and held harmless by the customer from any and all claims by any person relating to such customer's use of services so provided.

(G) No license under patents (other than the limited license to use) is granted by the Telephone Company or shall be implied or arise by estoppel, with respect to any service offered under this tariff. The Telephone Company will defend the customer against claims of patent infringement arising solely from the use by the customer of services offered under this tariff and will indemnify such customer for any damages awarded based solely on such claims.

(H) The Telephone Company's failure to provide or maintain services under this tariff shall be excused by labor difficulties, governmental orders, civil commotions, criminal actions taken against the Telephone Company, acts of God and other circumstances beyond the Telephone Company's reasonable control, subject to the Credit Allowance for a Service Interruption as set forth in 2.4.4 following.

2.1.4 Provision of Services

The Telephone Company, to the extent that such services are or can be made available with reasonable effort, and after provision has been made for the Telephone Company's Telephone Exchange Services, will provide to the customer upon reasonable notice services offered in other applicable sections of this tariff at rates and charges specified therein.

The Telephone Company may discontinue certain Telephone Company services in geographic areas for which the Telephone Company has no customers subscribing to those services and has received no reasonable requests within the prior 30 days.

(N)
(N)
(N)
(N)

ISSUED: JUNE 16, 2011

EFFECTIVE: JULY 1, 2011

ACCESS SERVICE

2 - General Regulations (Cont'd)

2.1 Undertaking of the Telephone Company (Cont'd)

2.1.5 Installation and Termination of Services

With the exception of BellSouth Virtual Expanded Interconnection arrangements the Access Services provided under this tariff (A) will include any entrance cable or drop wiring and wire or intrabuilding cable to that point where provision is made for termination of the Telephone Company's outside distribution network facilities at a suitable location inside a customer-designated premises and (B) will be installed by the Telephone Company to such Point of Termination. Each Access Service has only one Point of Termination per customer premises. Any additional terminations beyond such Point of Termination is the sole responsibility of the customer. The Point of Termination is an inherent part of BellSouth SWA and Special Access (a.k.a. BellSouth SPA) services, therefore, the preceding does not preclude the customer's ability to have each Point of Termination moved as set forth in 6.7.7 and 7.4.5 following for BellSouth SWA and Special Access (a.k.a. BellSouth SPA) services, respectively.

Provisions addressing BellSouth Virtual Expanded Interconnection arrangements are contained in Section 20 following.

2.1.6 Maintenance of Services

The services provided under this tariff shall be maintained by the Telephone Company. The customer or others may not rearrange, move, disconnect, remove or attempt to repair any facilities provided by the Telephone Company other than by connection or disconnection to any interface means used, except with the written consent of the Telephone Company.

2.1.7 Changes and Substitutions

Except as provided for equipment and systems subject to F.C.C. Part 68 Regulations at 47 C.F.R. Section 68.110(b), the Telephone Company may, where such action is reasonably required in the operation of its business, (A) substitute, change or rearrange any facilities used in providing service under this tariff, including but not limited to, (1) substitution of different metallic facilities, (2) substitution of carrier or derived facilities for metallic facilities used to provide other than metallic facilities and (3) substitution of metallic facilities for carrier or derived facilities used to provide other than metallic facilities, (B) change minimum protection criteria, (C) change operating or maintenance characteristics of facilities or (D) change operations or procedures of the Telephone Company. In case of any such substitution, change or rearrangement, the transmission parameters will

ISSUED: JUNE 30, 2020

EFFECTIVE: JULY 15, 2020

ACCESS SERVICE

2 - General Regulations (Cont'd)

2.1 Undertaking of the Telephone Company (Cont'd)

2.1.7 Changes and Substitutions (Cont'd)

be within the range as set forth in Section 6 and Section 7 following. The Telephone Company shall not be responsible if any such substitution, change or rearrangement renders any customer furnished services obsolete or requires modification or alteration thereof or otherwise affects their use or performance. If such substitution, change or rearrangement materially affects the operating characteristics of the facility, the Telephone Company will provide reasonable notification to the customer in writing. Reasonable time will be allowed for any redesign and implementation required by the change in operating characteristics. The Telephone Company will work cooperatively with the customer to determine reasonable notification requirements.

2.1.8 Refusal and Discontinuance of Service

- (A) Unless the provisions of 2.2.1(B) or 2.5 following apply, if a customer fails to comply with 2.1.6 preceding or 2.2.2, 2.3.1, 2.3.4, 2.3.5, 2.3.10 or 2.4 following, including any payments to be made by it on the dates and times herein specified, the Telephone Company may, on thirty (30) calendar days written notice by Certified U.S. Mail or Overnight Delivery to the person designated by that customer to receive such notices of noncompliance, refuse additional applications for service and/or refuse to complete any pending orders for service by the noncomplying customer at any time thereafter. If the Telephone Company does not refuse additional applications for service on the date specified in the thirty (30) days notice, and the customer's noncompliance continues, nothing contained herein shall preclude the Telephone Company's right to refuse additional applications for service to the noncomplying customer without further notice.
- (B) Unless the provisions of 2.2.1(B) or 2.5 following apply, if a customer fails to comply with 2.1.6 preceding or 2.2.2, 2.3.1, 2.3.4, 2.3.5, 2.3.10 or 2.4 following, including any payments to be made by it on the dates and times herein specified, the Telephone Company may, on thirty (30) calendar days written notice by Certified U.S. Mail or Overnight Delivery to the person designated by that customer to receive such notices of noncompliance, discontinue the provision of the services to the noncomplying customer at any time thereafter. In the case of such discontinuance, all applicable charges, including termination charges, shall become due. If the Telephone Company does not discontinue the provision of the services involved on the date specified in the thirty (30) days notice, and the customer's noncompliance continues, nothing contained herein shall preclude the Telephone Company's right to discontinue the provision of the services to the noncomplying customer without further notice.

ISSUED: JUNE 30, 2020

EFFECTIVE: JULY 15, 2020

ACCESS SERVICE

2 - General Regulations (Cont'd)

2.1 Undertaking of the Telephone Company (Cont'd)

2.1.8 Refusal and Discontinuance of Service (Cont'd)

(C) In addition to and not in limitation of the provisions of 2.1.8(A) and 2.1.8(B) preceding, unless the provisions of 2.2.1(B) or 2.5 following apply, if a customer fails to comply with 2.4.1(A) or with 2.4.1(B)(3) following, including any payments to be made by it on the dates and times herein specified, the Telephone Company may take the actions specified in 2.1.8(A) and 2.1.8(B) on fifteen (15) calendar days written notice, such notice period to start the day after the notice is rendered by Certified Mail or Overnight Delivery, if the customer has not complied with respect to amounts due in a subject bill and either:

(1) The Telephone Company has within (7) business days of the subject bill date:

- a. Mailed via the United States Postal Service (USPS) to the customer the subject bill in paper or CDROM form, or
- b. Overnight service delivered to the customer the subject bill in Magnetic Tape form, or
- c. Electronically Transmitted to the customer the subject bill.

The Telephone Company will maintain records sufficient to validate the date upon which a subject bill was rendered to the customer.

(2) The Telephone Company has rendered the subject bill, using one of the media described in (1) above, to the customer more than thirty (30) calendar days before notice under this section has been rendered.

In all other cases, the Telephone Company will give thirty (30) calendar days written notice pursuant to 2.1.8(A) or 2.1.8(B). Action will not be taken with regard to the subject bill if the customer cures the noncompliance prior to the expiration of the fifteen (15) or thirty (30) calendar day notice period, as applicable.

(D) If the National Exchange Carrier Association, Inc., notifies the Telephone Company in writing that the Customer has failed to comply with

ISSUED: JUNE 30, 2020

EFFECTIVE: JULY 15, 2020

ACCESS SERVICE

2 - General Regulations (Cont'd)

2.1 Undertaking of the Telephone Company (Cont'd)

2.1.8 Refusal and Discontinuance of Service (Cont'd)

(D) (Cont'd)

Section 8 of the NATIONAL EXCHANGE CARRIER ASSOCIATION, INC. (NECA) TARIFF F.C.C. NO. 5 (Lifeline Assistance and Federal Universal Service Fund (FUSF) Surcharges) including any Customer's failure to make payments on the date and time specified therein, the Telephone Company, may, on thirty days' written notice to the Customer by Certified U.S. Mail, take any of the following actions: - (1) refuse additional applications for service and/or (2) refuse to complete any pending orders for service and/or (3) discontinue the provision of existing service(s) to the Customer. In the case of discontinuance, all applicable charges, including termination charges, shall become due and payable to the Company in immediately available funds.

2.1.9 Limitation of Use of Metallic Facilities

Signals applied to the metallic facility shall conform to the limitations set forth in Technical Reference Publication AS No. 1. In the case of application of dc telegraph signaling systems, the customer shall be responsible, at its expense, for the provision of current limiting devices to protect the Telephone Company facilities from excessive current due to abnormal conditions and for the provision of noise mitigation networks when required to reduce excessive noise.

2.1.10 Notification of Service-Affecting Activities

The Telephone Company will provide the customer reasonable notification of service-affecting activities that may occur in normal operation of its business. Such activities may include, but are not limited to, equipment or facilities additions, removals or rearrangements, routine preventative maintenance and major switching machine change-out. Generally, such activities are not individual customer service specific, they affect many customer services. No specific advance notification period is applicable to all service activities. The Telephone Company will work cooperatively with the customer to determine reasonable notification requirements.

2.1.11 Coordination with Respect to Network Contingencies

The Telephone Company intends to work cooperatively with the customer to develop network contingency plans in order to maintain maximum network capability following natural or man-made disasters which affect telecommunication services.

This includes developing plans for originating or terminating traffic associated with mass calling events directed to end users served from specific end offices. Where it is determined that such non-random calling generates

ISSUED: JUNE 30, 2020

EFFECTIVE: JULY 15, 2020

ACCESS SERVICE

2 - General Regulations (Cont'd)

2.1 Undertaking of the Telephone Company (Cont'd)

2.1.11 Coordination with Respect to Network Contingencies (Cont'd)

problems on the Telephone Company's Common Transport network, the Telephone Company will work cooperatively with the customer to relieve the traffic congestion. Remedial measures may include isolation of the customer from the Telephone Company network in the impacted area for the duration of the problem or until the customer notifies the Telephone Company that the problem has been resolved.

2.1.12 Provision and Ownership of Telephone Numbers

The Telephone Company reserves the reasonable right to assign, designate or change telephone numbers, any other call number designations associated with Access Service, or the Telephone Company serving central office prefixes associated with such numbers, when necessary in the conduct of its business. Should it become necessary to make a change in such number(s), the Telephone Company will furnish to the customer 6 months notice, by certified U.S. Mail, of the effective date and an explanation of the reason(s) for such change(s).

2.1.13 Metropolitan Statistical Area Access Services

For the Metropolitan Statistical Areas (MSAs) in which the Telephone Company has received Phase II pricing flexibility, pursuant to Subpart H of Part 69 of the Commission's Rules, Section 23 of this Tariff governs the offering of service in these MSAs.

2.1.14 Broadband Services

Pursuant to the detariffing authority granted by the Commission in Memorandum Opinion and Order, FCC 07-180 (released October 12, 2007), certain broadband services have been withdrawn from this tariff. When offering these services through non-tariffed arrangements, the Telephone Company will abide by all of the special access merger commitments set forth in Memorandum Opinion and Order, FCC 06-189 at Appendix F (released March 26, 2007), including but not limited to commitments that contain references to "tariffs," such as those addressing pricing, dispute resolution, and access service ratio terms. The detariffing of these services does not diminish or supersede any of those special access merger commitments.

ISSUED: DECEMBER 16, 2022

EFFECTIVE: JANUARY 1, 2023

ACCESS SERVICE

2 - General Regulations (Cont'd)

2.1.15 TDM to IP Transition

(A) As a result of evolving network technology, the Telephone Company is able to offer new, advanced services. At the same time, certain older services will no longer be available in some geographic areas, as those services are no longer technically or economically feasible. The table below identifies services that have been withdrawn, by wire center and exchange, along with additional information related to these service withdrawals.

(1) Withdrawn Services Effective September 20, 2017

<u>Product Name</u>	<u>Section</u>	
-Metallic (aka BellSouth SPA Metallic) Service	7.2.1	
-Telegraph Grade (aka BellSouth SPA Telegraph) Service	7.2.2	
-Voice Grade (aka BellSouth SPA DSO VG) Service	7.2.3	
-Program Audio ⁽¹⁾ (aka BellSouth SPA Program Audio) Service	7.2.4	(N)
-Digital Data Access (aka BellSouth SPA DSO Digital Data) Service	7.2.8	
-High Capacity (aka BellSouth SPA High Capacity) Service (at 64.0 kbps, 3.152 and 6.312 Mbps)	7.2.9	
-Derived Data Channel (aka BellSouth SPA Derived Data Channel) Service	7.2.12	

Effective Date Wire Center Exchange Other Information

⁽¹⁾ Program Audio is discontinued and no longer available in this publication (see WC Dkt. 19-238).

(N)
(N)

ISSUED: JUNE 30, 2020

EFFECTIVE: JULY 15, 2020

ACCESS SERVICE

2 - General Regulations (Cont'd)

2.1 Undertaking of the Telephone Company (Cont'd)

2.2 Use

2.2.1 Interference or Impairment

- (A) The characteristics and methods of operation of any circuits, facilities or equipment provided by other than the Telephone Company and associated with the facilities utilized to provide services under this tariff shall not interfere with or impair service over any facilities of the Telephone Company, its affiliated companies, or its connecting and concurring carriers involved in its services, cause damage to their plant, impair the privacy of any communications carried over their facilities or create hazards to the employees of any of them or the public.

ISSUED: JULY 30, 2024

EFFECTIVE: AUGUST 1, 2024

ACCESS SERVICE

2 - General Regulations (Cont'd)

2.2 Use (Cont'd)

2.2.1 Interference or Impairment (Cont'd)

- (B) Except as provided for equipment or systems subject to the F.C.C. Part 68 Rules in 47 C.F.R. Section 68.108, if such characteristics or methods of operation are not in accordance with (A) preceding, the Telephone Company will, where practicable, notify the customer that temporary discontinuance of the use of a service may be required; however, where prior notice is not practicable, nothing contained herein shall be deemed to preclude the Telephone Company's right to temporarily discontinue forthwith the use of a service if such action is reasonable under the circumstances. In case of such temporary discontinuance, the customer will be promptly notified and afforded the opportunity to correct the condition which gave rise to the temporary discontinuance. During such period of temporary discontinuance, credit allowance for service interruptions as set forth in 2.4.4(A) and (B) following is not applicable.

2.2.2 Unlawful Use

The service provided under this tariff shall not be used for an unlawful purpose.

2.2.3 Commingling

- (A) Except as provided in Section 51.318 of the Federal Communications Commission's rules, telecommunications carriers who obtain unbundled network elements (UNEs) or combinations of UNEs pursuant to a Statement of Generally Available Terms, under Section 252 of the Act, or pursuant to an interconnection agreement with the Telephone Company, may connect, combine, or otherwise attach such UNEs or combinations of UNEs to Access services purchased under this Tariff except to the extent such agreement explicitly:
 - (1) prohibits such commingling; or
 - (2) requires the parties to complete the procedures set forth in the agreement regarding change of law prior to implementing such commingling.
- (B) The rates, terms, and conditions of this Tariff will apply to the Access Services that are commingled.
- (C) UNEs or combinations of UNEs that are commingled with Access Services are not included in the shared use provisions of this Tariff.

(Dx)

(Dx)

—
(Dx)

- (x) Issued under authority of Special Permission No. 24-006 of the FCC in order to withdraw material filed under Transmittal No. 186 and Transmittal No. 188.

ISSUED: JUNE 16, 2011

EFFECTIVE: JULY 1, 2011

ACCESS SERVICE

2 - General Regulations (Cont'd)

2.3 Obligations of the Customer

2.3.1 Damages

The customer shall reimburse the Telephone Company for damages to Telephone Company facilities utilized to provide services under this tariff caused by the negligence or willful act of the customer, or resulting from the customer's improper use of the Telephone Company facilities, or due to malfunction of any facilities or equipment provided by other than the Telephone Company. Nothing in the foregoing provision shall be interpreted to hold one customer liable for another customer's actions. The Telephone Company will, upon reimbursement for damages, cooperate with the customer in prosecuting a claim against the person causing such damage and the customer shall be subrogated to the right of recovery by the Telephone Company for the damages to the extent of such payment.

ISSUED: JUNE 16, 2011

EFFECTIVE: JULY 1, 2011

ACCESS SERVICE

2 - General Regulations (Cont'd)

2.3 Obligations of the Customer (Cont'd)

2.3.2 Ownership of Facilities and Theft

Facilities utilized by the Telephone Company to provide service under the provisions of this tariff shall remain the property of the Telephone Company. Such facilities shall be returned to the Telephone Company by the customer, whenever requested, within a reasonable period following the request in as good condition as reasonable wear will permit.

2.3.3 Equipment Space and Power

The customer shall furnish or arrange to have furnished to the Telephone Company, at no charge, equipment space and electrical power required by the Telephone Company to provide services under this tariff at the points of termination of such services. The selection of ac or dc power shall be mutually agreed to by the customer and the Telephone Company. The customer shall also make necessary arrangements in order that the Telephone Company will have access to such spaces at reasonable times for installing, testing, repairing or removing Telephone Company services.

2.3.4 Availability for Testing

The services provided under this tariff shall be available to the Telephone Company at times mutually agreed upon in order to permit the Telephone Company to make tests and adjustments appropriate for maintaining the services in satisfactory operating condition. Such tests and adjustments shall be completed within a reasonable time. No credit will be allowed for any interruptions involved during such tests and adjustments.

2.3.5 Balance

All signals for transmission over the services provided under this tariff shall be delivered by the customer balanced to ground except for ground start, duplex (DX) and McCulloh-Loop (Alarm System) type signaling and dc telegraph transmission at speeds of 75 baud or less.

2.3.6 Design of Customer Services

Subject to the provisions of 2.1.7 preceding, the customer shall be solely responsible, at its own expense, for the overall design of its services and for any redesigning or rearrangement of its services which may be required because of changes in facilities, operations or

ISSUED: JUNE 16, 2011

EFFECTIVE: JULY 1, 2011

ACCESS SERVICE

2 - General Regulations (Cont'd)

2.3 Obligations of the Customer (Cont'd)

2.3.6 Design of Customer Services (Cont'd)

procedures of the Telephone Company, minimum protection criteria or operating or maintenance characteristics of the facilities.

2.3.7 References to the Telephone Company

The customer may, in response to direct customer inquiry, advise End Users that certain services are provided by the Telephone Company in connection with the service the customer furnishes to End Users; however, the customer shall not represent that the Telephone Company jointly participates in the customer's services. Names of Telephone Company services and Service Marks or Trademarks owned by BellSouth Intellectual Property Corporation may not be used by any entity obtaining services pursuant to this tariff except under an express, written, license agreement with the Telephone Company or BellSouth Intellectual Property Marketing Corporation.

2.3.8 Claims and Demands for Damages

- (A) With respect to claims of patent infringement made by third persons, the customer shall defend, indemnify, protect and save harmless the Telephone Company from and against all claims arising out of the combining with, or use in connection with, the services provided under this tariff, any circuit, apparatus, system or method provided by the customer.
- (B) The customer shall defend, indemnify and save harmless the Telephone Company from and against any suits, claims, losses or demands including punitive damages, attorney fees and court costs by third persons arising out of the construction, installation, operation, maintenance, or removal of the customer's circuits, facilities, or equipment connected to the Telephone Company's services provided under this tariff, including, without limitation, Workmen's Compensation claims, actions for infringement of copyright and/or unauthorized use of program material, libel and slander actions based on the content of communications transmitted over the customer's circuits, facilities or equipment, and proceedings to recover taxes, fines, or penalties for failure of the customer to obtain or maintain in effect any necessary certificates, permits, licenses, or other authority to acquire or operate the services provided under this tariff; provided, however, the foregoing indemnification shall not apply to suits, claims, and demands to recover damages for damage to property, death, or personal injury unless such suits, claims or demands are based on the tortious conduct of the customer, its officers, agents or employees.

ISSUED: May 10, 2001

EFFECTIVE: May 15, 2001

ACCESS SERVICE

2 - General Regulations (Cont'd)

2.3 Obligations of the Customer (Cont'd)

2.3.9 Coordination with Respect to Network Contingencies

The customer shall, in cooperation with the Telephone Company, coordinate in planning the actions to be taken to maintain maximum network capability following natural or man-made disasters, which affect telecommunications services.

2.3.10 Jurisdictional Report Requirements¹

(A) Jurisdictional Reports

(1) Percent Interstate Usage (PIU)

(a)

The interstate usage is to be developed as though every call that originates from a calling location (as designated by the calling station number) in a state other than that where the called station (as designated by the called number) is situated is an interstate communication. The manner in which a call is routed through the telecommunications network does not affect the jurisdiction of a call, i.e., a call between two points within the same state is an intrastate call even if it is routed through another state.

(b) When the Telephone Company receives sufficient call detail to permit it to determine the jurisdiction of originating and terminating access minutes of use or message, the Telephone Company will bill according to these actual minutes of use and will not use customer reported Percent Interstate Usage (PIU) factors.

The Telephone Company developed percent interstate usage for access minutes of use will be determined at a statewide level. The interstate percentage will be developed on a monthly basis by end office, when the access minutes are measured by dividing the measured interstate originating or terminating access minutes (the access minutes where the calling number is in one state and the called number is in another state) by the total originating or terminating access minutes.

Note 1: Except where indicated herein, references to BellSouth SWA FGs will also include the applicable BellSouth Basic Serving Arrangement as detailed in Section 6.1.3.(A)(5)(j) (e.g., the term BellSouth SWA FGA represents both BellSouth SWA FGA and BellSouth SWA LSBSA).

ISSUED: JUNE 30, 2020

EFFECTIVE: JULY 15, 2020

ACCESS SERVICE

2 - General Regulations (Cont'd)

2.3 Obligations of the Customer (Cont'd)

2.3.10 Jurisdictional Report Requirements¹ (Cont'd)

(A) Jurisdictional Reports (Cont'd)

(1) Percent Interstate Usage (PIU) (Cont'd)

(b) (Cont'd)

The Telephone Company will bill according to actual measured minutes of use or messages for all services listed in (1)(c) and (2) following, with the exception of those listed below:

- BellSouth SWA Local Channel
- BellSouth SWA Dedicated Interoffice Channel
- BellSouth Billing Name and Address
- BellSouth Inward Operator Service
- BellSouth Line Information Data Base Service (LIDB)
- Virtual Access Cross Connect Service
- Physical Access Cross Connect Service
- Intra-Office Collocation Cross Connect Service
- BellSouth Electronic White Pages Access Service
- BellSouth Operator Assistance Access Service
- BellSouth Flat Rated DA Trunk
- Channelization Equipment
- DNALS associated with BellSouth SWA LSBSA

Where the Telephone Company receives insufficient call detail to determine the jurisdiction, the Telephone Company will apply the customer's projected PIU factor to apportion the usage between interstate and intrastate. In the event the customer does not supply the projected PIU and the Telephone Company does not have sufficient call detail to determine the jurisdiction of the call, only then will a PIU of 50 percent be applied. For the purpose of this tariff, where the customer is a Third-Party Provider ("Third-Party Provider") of CCS7 services to its customers ("Third-Party Customers"), the Third-Party Provider will develop its projected PIU factor based upon a weighted average of the PIUs of its Third-Party Customers' end user traffic in accordance with the procedures described below. A Third-Party Provider may elect to have the

Note 1: Except where indicated herein, references to BellSouth SWA FGs will also include the applicable BellSouth Basic Serving Arrangement as detailed in Section 6.1.3.(A)(5)(j) (e.g., the term BellSouth SWA FGA represents both BellSouth SWA FGA and BellSouth SWA LSBSA).

ISSUED: JUNE 30, 2020

EFFECTIVE: JULY 15, 2020

ACCESS SERVICE

2 - General Regulations (Cont'd)

2.3 Obligations of the Customer (Cont'd)

2.3.10 Jurisdictional Report Requirements¹ (Cont'd)

(A) Jurisdictional Reports (Cont'd)

(1) Percent Interstate Usage (PIU) (Cont'd)

(b) (Cont'd)

Telephone Company determine the weighted PIU and in so doing the Third-Party Provider shall name and identify their Third Party Customers. In the event a Third Party Provider does not provide a projected PIU or does not elect to have the Telephone Company determine the PIU, a 50 percent PIU will be utilized for that Third-Party Provider, until such time as the Telephone Company obtains sufficient data to develop the PIU as specified in c. following.

The customer will provide in its initial order the projected Percent Interstate Usage (PIU) at a statewide level on a local exchange company specific basis. When the customer computes the PIU it will subtract the developed PIU from 100 and the difference is the percent intrastate usage. The sum of the interstate and intrastate percentages will equal 100 percent. A PIU of less than 100 percent is not allowed where the interstate service is not also available in the appropriate intrastate access tariff. The projected PIU may include up to two decimals.

The Telephone Company will designate the number obtained by subtracting the projected interstate percentage furnished by the customer from 100 ($100 - \text{customer percentage} = \text{intrastate percentage}$) as the projected intrastate percentage of use.

For usage originating from or terminating to an end office that is located in a state that is part of a LATA of a different state (cross boundary), the customer will provide a statewide PIU per service type for the state where the end office is physically located.

- (c) When the customer initially orders service(s), as defined in the following, the customer will state in its order the Percent Interstate Usage separately for each, as set forth in (1)(a) and (1)(b) preceding.

Note 1: Except where indicated herein, references to BellSouth SWA FGs will also include the applicable BellSouth Basic Serving Arrangement as detailed in Section 6.1.3.(A)(5)(j) (e.g., the term BellSouth SWA FGA represents both BellSouth SWA FGA and BellSouth SWA LSBSA).

ISSUED: JUNE 30, 2020

EFFECTIVE: JULY 15, 2020

ACCESS SERVICE

2 - General Regulations (Cont'd)

2.3 Obligations of the Customer (Cont'd)

2.3.10 Jurisdictional Report Requirements¹ (Cont'd)

(A) Jurisdictional Reports (Cont'd)

(1) Percent Interstate Usage (PIU) (Cont'd)

(c) (Cont'd)

- BellSouth SWA FGA
- BellSouth SWA FGB
- BellSouth SWA FGD
- BellSouth SWA 500
- 700 Service Access
- BellSouth SWA 8XX Toll Free Dialing Ten Digit Screening Service
- BellSouth SWA 900
- BellSouth SWA Local Channel
- BellSouth SWA Dedicated Interoffice Channel
- BellSouth CCS7 Access Arrangement
- Channelization Equipment
- DNALs associated with BellSouth SWA LSBSA²
- Virtual Access Cross Connect Service
- Physical Access Cross Connect Service
- Intra-Office Collocation Cross Connect Service
- BellSouth Billing Name and Address
- BellSouth Inward Operator Services
- BellSouth Line Information Data Base Service (LIDB)
- BellSouth Electronic White Pages Access Service
- BellSouth Operator Assistance Access Service
- BellSouth Flat Rated DA Trunks

The Percent Interstate Usage (PIU) factors associated with BellSouth SWA FGA, BellSouth SWA FGB, BellSouth SWA FGD, BellSouth SWA 500, 700, BellSouth SWA 8XX Toll Free Dialing Ten Digit Screening service, and BellSouth SWA 900, will apply to all associated elements and services, e.g., Carrier Common Line, Local Switching, BellSouth SWA Common Interoffice Channel, Interconnection, Access Tandem Switching, Common Trunk Port service and minute of use based multiplexer rate elements, where applicable.

Note 1: Except where indicated herein, references to BellSouth SWA FGs will also include the applicable BellSouth SWA Basic Serving Arrangement as detailed in Section 6.1.3.(A)(5)(j) (e.g., the term BellSouth SWA FGA represents both BellSouth SWA FGA and BellSouth SWA LSBSA).

Note 2: Where BellSouth SWA LSBSA is provisioned with a DNAL, the DNAL rates should be apportioned between interstate and intrastate using the same PIU factor as is applied to the associated BellSouth SWA LSBSA.

ISSUED: JUNE 30, 2020

EFFECTIVE: JULY 15, 2020

ACCESS SERVICE

2 - General Regulations (Cont'd)

2.3 Obligations of the Customer (Cont'd)

2.3.10 Jurisdictional Report Requirements¹ (Cont'd)

(A) Jurisdictional Reports (Cont'd)

(1) Percent Interstate Usage (PIU) (Cont'd)

(c) (Cont'd)

The customer will provide a single factor as the projected Percent Interstate Usage (PIU) to apportion the usage between interstate and intrastate. This factor will be applied to the following categories:

- BellSouth SWA Local Channel
- BellSouth SWA Dedicated Interoffice Channel
- Channelization Equipment

The PIU category, BellSouth SWA Local Channel, includes Dedicated End Office Trunk Port Service and Dedicated Tandem Trunk Port Service charges and other flat rated charges not specifically covered by other PIU categories.

The PIU factor provided for each of the foregoing facilities categories (Switched Local Channel, Switched Dedicated Interoffice Channel, Channelization Equipment and Switched Virtual and Physical Access Cross Connect Service) will reflect the combination of all traffic types which traverse such facility category.

Note 1: Except where indicated herein, references to BellSouth SWA FGs will also include the applicable BellSouth Basic Serving Arrangement as detailed in Section 6.1.3.(A)(5)(j) (e.g., the term BellSouth SWA FGA represents both BellSouth SWA FGA and BellSouth SWA LSBSA).

ISSUED: SEPTEMBER 12, 2012

EFFECTIVE: SEPTEMBER 27, 2012

ACCESS SERVICE
2 - General Regulations (Cont'd)

2.3 Obligations of the Customer (Cont'd)

2.3.10 Jurisdictional Report Requirements¹ (Cont'd)

(A) Jurisdictional Reports (Cont'd)

(1) Percent Interstate Usage (PIU) (Cont'd)

(c) (Cont'd)

When Special Access (a.k.a. BellSouth SPA) service is provided on a BellSouth SWA Access Facility, e.g. Special Access (a.k.a. BellSouth SPA) DS1 on a BellSouth SWA DS3, the facility will be apportioned between BellSouth SWA and Special Access (a.k.a. BellSouth SPA). The jurisdiction of the Special Access (a.k.a. BellSouth SPA) service will reflect the composite of the jurisdiction of the lower capacity services, if any, of which it is comprised, and the regulations in 2.3.12, following, will apply.

The customer will compute the PIU using the following formula (rounded to a whole percentage).

Total Interstate Originating Minutes	+	Total Interstate Terminating Minutes

Total Originating Minutes	+	Total Terminating Minutes

(D)

(D)

Note 1: Except where indicated herein, references to BellSouth SWA FGs will also include the applicable BellSouth SWA Basic Serving Arrangement, as detailed in Section 6.1.3(A)(5)(j) (e.g., the term BellSouth SWA FGA represents both BellSouth SWA FGA and BellSouth SWA LSBSA).

ISSUED: JUNE 16, 2011

EFFECTIVE: JULY 1, 2011

ACCESS SERVICE

2 - General Regulations (Cont'd)

2.3 Obligations of the Customer (Cont'd)

2.3.10 Jurisdictional Report Requirements¹ (Cont'd)

(A) Jurisdictional Reports (Cont'd)

- (2) For BellSouth Directory Assistance Access Service and BellSouth Direct Access to Directory Assistance Service, the Telephone Company developed PIU for BellSouth SWA FGD terminating will apply. For BellSouth Electronic White Pages Access service, the customer's projected interstate percent usage (PIU) will be applied.
- (3) For BellSouth Operator Assistance Access Service and BellSouth Flat Rated DA Trunks, the customer must state in its order the PIU anticipated as specified in 2.3.10(A)(1)(c) preceding. The customer may only report a PIU of less than 100%, where the service is also available for intrastate use. Subsequent PIU factors will be reported as required in (5) following.
- (4) For BellSouth CCS7 Access Arrangement, the customer must state in its order the PIU anticipated as specified in 2.3.10(A)(1)(c) preceding. The PIU reported will then be applied to the rates for Signaling Connections and Terminations to arrive at the amount the customer is billed for interstate usage of these facilities each month.

Note 1: Except where indicated herein, references to BellSouth SWA FGs will also include the applicable BellSouth SWA Basic Serving Arrangement as detailed in Section 6.1.3(A)(5)(j) (e.g., the term BellSouth SWA FGA represents both BellSouth SWA FGA and BellSouth SWA LSBSA).

ISSUED: JUNE 16, 2011

EFFECTIVE: JULY 1, 2011

ACCESS SERVICE

2 - General Regulations (Cont'd)

2.3 Obligations of the Customer (Cont'd)

2.3.10 Jurisdictional Report Requirements¹ (Cont'd)

(A) Jurisdictional Reports (Cont'd)

(4) (Cont'd)

In addition, the PIU will be applied to the total messages and the resulting figure multiplied by the appropriate rate per message to determine the amount that the customer will be billed for interstate usage. Subsequent PIU factors will be reported as required in (5) following.

- (5) Effective July 1, 2001 the customer will update the jurisdictional report associated with BellSouth Operator Assistance Access Service, BellSouth Flat Rated DA Trunks and BellSouth CCS7 Access Arrangement, when both interstate and intrastate service is provided.

Effective October 1, 2000, the customer will provide a single factor as the projected Percent Interstate Usage (PIU) to apportion the usage between interstate and intrastate. This PIU factor will apply to the following categories: BellSouth SWA Local Channel, BellSouth SWA Dedicated Interoffice Channel and Channelization Equipment.

Effective July 1, 2000, the customer's projected Percent Interstate Usage (PIU) will be provided at a statewide level on a local exchange company basis.

Effective on the first of January, April, July and October of each year the customer will update the interstate and intrastate jurisdictional report, except where Telephone Company Measured Access minutes are used as set forth in (1) preceding. The customer will forward to the Telephone Company, to be received no later than 30 days after the first of each such month, a revised report or letter for all services showing the interstate and intrastate percentage of use for the past three months ending the last day of December, March, June and September, respectively, for each service arranged for interstate use.

Note 1: Except where indicated herein, references to BellSouth SWA FGs will also include the applicable BellSouth SWA Basic Serving Arrangement as detailed in Section 6.1.3(A)(5)(j) (e.g., the term BellSouth SWA FGA represents both BellSouth SWA FGA and BellSouth SWA LSBSA).

ISSUED: May 10, 2001

EFFECTIVE: May 15, 2001

ACCESS SERVICE

2 - General Regulations (Cont'd)

2.3 Obligations of the Customer (Cont'd)

2.3.10 Jurisdictional Report Requirements¹ (Cont'd)

(A) Jurisdictional Reports (Cont'd)

(5) (Cont'd)

The revised report or letter will serve as the basis for the next three months' billing and will be effective on the bill date for that service. If the customer does not supply an updated quarterly report or letter, the Telephone Company will assume percentages to be the same as those provided in the last quarterly report or letter accepted by the Telephone Company. If an audit has been completed and an updated quarterly report or letter has not been submitted subsequent to the audit, the Telephone Company will assume the PIU factors to be the most recent audited results. For those cases in which a quarterly report or letter has never been received from the customer, the Telephone Company will assume the PIU factors to be the most recent audit results, to be the same as provided in the order for service if no audit has been performed, or 50 percent.

(B) Jurisdictional Report Verification

- (1) When a customer provides a projected interstate usage percent as set forth in (A) preceding, or when a billing dispute arises or a regulatory commission questions the projected interstate percentage for Access, the Telephone Company may, by written request, require the customer to provide the data the customer used to determine the projected interstate percentage. In the case of a third-party provider of CCS7 service to Third-Party Customers as described in (A), preceding, the data will include the data provided by the Third-Party Customers. This written request will be considered the initiation of the audit. The customer shall supply the data to an independent auditor or the Telephone Company within 30 days of the Telephone Company request. The customer shall keep records of call detail from which the percentage of interstate and intrastate use can be ascertained as set forth in (C) following and upon request of the Telephone Company make the records available for inspection at an agreed upon location during normal business hours as reasonably necessary for purposes of verification of the percentages. The Telephone Company will audit data from one quarter unless a longer period is requested by the customer and agreed to by the Telephone Company.

Note 1: Except where indicated herein, references to BellSouth SWA FGs will also include the applicable BellSouth SWA Basic Serving Arrangement as detailed in Section 6.1.3(A)(5)(j) (e.g., the term BellSouth SWA FGA represents both BellSouth SWA FGA and BellSouth SWA LSBSA).

ISSUED: JUNE 16, 2011

EFFECTIVE: JULY 1, 2011

ACCESS SERVICE

2 - General Regulations (Cont'd)

2.3 Obligations of the Customer (Cont'd)

2.3.10 Jurisdictional Report Requirements¹ (Cont'd)

(B) Jurisdictional Report Verification (Cont'd)

(1) (Cont'd)

Changes to the reported PIU will not be made for the test period. If the customer does not provide the requested data to the Telephone Company or independent auditor within thirty (30) days of the notice of audit, the customer will be in violation of this Tariff and subject to 2.1.8 preceding.

- (2) For BellSouth SWA service, verification audits may be conducted no more frequently than once per year except in extreme circumstances. The Telephone Company and customer will attempt to limit the audit to a reasonable time to effectively complete the audit. The Telephone Company and customer shall respond promptly to requests generated during the audit to ensure timely completion of the audit.
- (3) Audits may be conducted by: (a) an independent auditor under contract to the Telephone Company; (b) a mutually agreed upon independent auditor; or (c) an independent auditor selected and paid for by the customer. If the customer selects option (c), where it pays for its own independent audit, the selected auditor must certify that the audit was performed following F.C.C. procedures for measuring interstate traffic as established by Commission Order, and provide to the Telephone Company a report with supporting documentation to verify such procedures.

Note 1: Except where indicated herein, references to BellSouth SWA FGs will also include the applicable BellSouth SWA Basic Serving Arrangement as detailed in Section 6.1.3(A)(5)(j) (e.g., the term BellSouth SWA FGA represents both BellSouth SWA FGA and BellSouth SWA LSBSA).

ISSUED: JUNE 16, 2011

EFFECTIVE: JULY 1, 2011

ACCESS SERVICE

2 - General Regulations (Cont'd)

2.3 Obligations of the Customer (Cont'd)

2.3.10 Jurisdictional Report Requirements¹ (Cont'd)

(B) Jurisdictional Report Verification (Cont'd)

- (4) If a billing dispute arises or a regulatory commission questions the projected interstate percentage for Special Access (a.k.a. BellSouth SPA) service, the Telephone Company will ask the customer to provide the data the customer used to determine the projected interstate percentage. The customer shall supply the data within 30 days of the Telephone Company request. The customer shall keep records from which the percentage was determined and upon request of the Telephone Company make the records available for inspection as reasonably necessary for purposes of verification of the percentages.

(C) Maintenance of Customer Records for BellSouth SWA

- (1) The customer shall retain for a minimum of six (6) months call detail records that substantiate the interstate percent provided to the Telephone Company as set forth in (A) preceding for BellSouth SWA service. Such records shall consist of (a) and (b), if applicable, following:
 - (a) All call detail records such as workpapers and/or backup documentation including paper, magnetic tapes or any other form of records for billed customer traffic, call information including call terminating address (i.e., called number), the call duration, all originating and terminating trunk groups or access lines over which the call is routed, and the point at which the call enters the customer's network and;
 - (b) If the customer has a mechanized system in place that calculated the PIU, then a description of that system and the methodology used to calculate the PIU must be furnished and any other pertinent information (such as but not limited to flowcharts, source code, etc.) relating to such system must also be made available.

Note 1: Except where indicated herein, references to BellSouth SWA FGs will also include the applicable BellSouth SWA Basic Serving Arrangement as detailed in Section 6.1.3(A)(5)(j) (e.g., the term BellSouth SWA FGA represents both BellSouth SWA FGA and BellSouth SWA LSBSA).

ISSUED: JUNE 16, 2011

EFFECTIVE: JULY 1, 2011

ACCESS SERVICE

2 - General Regulations (Cont'd)

2.3 Obligations of the Customer (Cont'd)

2.3.10 Jurisdictional Report Requirements¹ (Cont'd)

(D) Audit Results for BellSouth SWA

- (1) Audit results will be furnished to the customer via Certified U.S. Mail (return receipt requested). The Telephone Company will adjust the customer's PIU based upon the audit results. The PIU resulting from the audit shall be applied to the usage for the quarter the audit is completed, the usage for the quarter prior to completion of the audit, and the usage for the two (2) quarters following the completion of the audit. After that time, the customer may report a revised PIU pursuant to (A) preceding. If the revised PIU submitted by the customer represents a deviation of 5 percentage points or more, from the audited PIU, and that deviation is not due to identifiable reasons, the provisions in (B) preceding may be applied.
- (2) Both credit and debit adjustments will be made to the customer's interstate access charges for the specified period to accurately reflect the interstate usage for the customer's account consistent with Section 2.4.1 following.
- (3) If, as a result of an audit conducted by an independent auditor, a customer is found to have over-stated the PIU by 20 percentage points or more, the Telephone Company shall require reimbursement from the customer for the cost of the audit. Such bill(s) shall be due and paid in immediately available funds 30 days from receipt and shall carry a late payment penalty as set forth in Section 2.4.1 following if not paid within the 30 days.

Note 1: Except where indicated herein, references to BellSouth SWA FGs will also include the applicable BellSouth SWA Basic Serving Arrangement as detailed in Section 6.1.3(A)(5)(j) (e.g., the term BellSouth SWA FGA represents both BellSouth SWA FGA and BellSouth SWA LSBSA).

ISSUED: JUNE 16, 2011

EFFECTIVE: JULY 1, 2011

ACCESS SERVICE

2 - General Regulations (Cont'd)

2.3 Obligations of the Customer (Cont'd)

2.3.10 Jurisdictional Report Requirements¹ (Cont'd)

(E) Contested Audits

- (1) When a PIU audit is conducted by an independent auditor selected by the Telephone Company, the audit results will be furnished to the customer by Certified U.S. Mail (return receipt requested). The customer may contest the audit results based on substantive cause by providing written notification, by Certified U.S. Mail (return receipt requested), to the Telephone Company within thirty (30) calendar days from the date the audit report is furnished to the customer. When a PIU audit is conducted by an independent auditor selected by the customer, the audit results will be furnished to the Telephone Company by Certified U.S. Mail (return receipt requested). The Telephone Company may contest the audit results by providing written notification, by Certified U.S. Mail (return receipt requested), to the customer within thirty (30) calendar days from the date the audit report is furnished to the Telephone Company.
- (2) Contested audits may be resolved by a neutral arbitrator mutually agreed upon by the Telephone Company and the customer. Arbitration is an option provided in addition to the customer's existing right to file a complaint or legal action in a court of law or at the FCC for resolution of the dispute. The arbitration hearing will be conducted in a state or location within the Telephone Company operating territory where the customer maintains a principle or significant presence or a state and location within the Telephone Company operating territory that is mutually agreed upon by both parties. The arbitration proceeding shall be governed by the law (both statutory and case) of the state in which the arbitration hearing is held, including, but not limited to, the Uniform Arbitration Act, as adopted in that state. The arbitrator shall determine the customer's PIU based on (A) preceding.

Note 1: Except where indicated herein, references to BellSouth SWA FGs will also include the applicable BellSouth SWA Basic Serving Arrangement as detailed in Section 6.1.3(A)(5)(j) (e.g., the term BellSouth SWA FGA represents both BellSouth SWA FGA and BellSouth SWA LSBSA).

ISSUED: JUNE 16, 2011

EFFECTIVE: JULY 1, 2011

ACCESS SERVICE

2 - General Regulations (Cont'd)

2.3 Obligations of the Customer (Cont'd)

2.3.10 Jurisdictional Report Requirements¹ (Cont'd)

(E) Contested Audits (Cont'd)

- (3) Prior to the arbitration hearing, each party shall notify the arbitrator of the PIU percentage which that party believes to be correct. The arbitrator, in deciding, may adopt the PIU percentage of either party or may adopt a PIU percentage different from those proposed by the parties. If the arbitrator adopts a PIU percentage proposed by one of the parties, the other party (whose PIU percentage was not adopted) shall pay all costs of the arbitration. If the arbitrator adopts a PIU percentage higher than either of the PIU percentages proposed by the parties, then the party proposing the lower PIU percentage shall pay all costs of the arbitration. If the arbitrator adopts a PIU percentage lower than either of the PIU percentages proposed by the parties, then the party proposing the higher PIU percentage shall pay all costs of the arbitration. If the arbitrator adopts a PIU percentage which falls between the two percentages adopted by the parties, then the parties shall each pay one-half of the arbitration costs.
- (4) Absent written notification, within the timeframe noted above, the customer must comply with the provisions set forth in (D) preceding. If the customer fails to comply with these provisions, the Telephone Company may refuse additional applications for service and/or refuse to complete any and all pending orders for service or may discontinue the provision of the services to the customer as specified in 2.1.8 preceding.

Note 1: Except where indicated herein, references to BellSouth SWA FGs will also include the applicable BellSouth SWA Basic Serving Arrangement as detailed in Section 6.1.3(A)(5)(j) (e.g., the term BellSouth SWA FGA represents both BellSouth SWA FGA and BellSouth SWA LSBSA).

ISSUED: SEPTEMBER 12, 2012

EFFECTIVE: SEPTEMBER 27, 2012

ACCESS SERVICE

2 - General Regulations (Cont'd)

2.3 Obligations of the Customer (Cont'd)

2.3.11 Determination of Interstate Charges for Mixed Interstate and Intrastate
BellSouth SWA Access Service (D)

When mixed interstate and intrastate BellSouth SWA Service, as described in 2.3.10(A)(1)(b) preceding, is provided, all charges (i.e., nonrecurring, monthly and/or usage) including optional feature charges, will be prorated between interstate and intrastate. The percentage provided in the reports as set forth in 2.3.10(A) preceding will serve as the basis for prorating the charges. The percentage of a BellSouth SWA Service to be charged as interstate is applied in the following manner: (D)

- (A) For monthly and nonrecurring chargeable rate elements multiply the percent interstate use times the quantity of chargeable elements times the stated tariff rate per element.
- (B) For usage sensitive (i.e., access minutes and calls) chargeable rate elements, multiply the percent interstate use times actual use (i.e., measured or Telephone Company assumed average use) times the stated tariff rate.

ISSUED: SEPTEMBER 12, 2012

EFFECTIVE: SEPTEMBER 27, 2012

ACCESS SERVICE

2 - General Regulations (Cont'd)

2.3 Obligations of the Customer (Cont'd)

2.3.11 Determination of Interstate Charges for Mixed Interstate and Intrastate BellSouth SWA (Cont'd)

(D)

(B) (Cont'd)

The interstate percentage will change as revised jurisdictional reports are submitted or as lines or trunks are added or removed as set forth in 2.3.10 preceding.

2.3.12 Determination of Jurisdiction of Mixed Interstate and Intrastate Special Access (a.k.a. BellSouth SPA) Service

When mixed interstate and intrastate Special Access (a.k.a. BellSouth SPA) service is provided, the jurisdiction will be determined as follows: (C)

- If the customer's estimate of the interstate traffic on the service involved constitutes 10% or less of the total traffic on that service, the service will be provided in accordance with the applicable rules and regulations of the appropriate intrastate tariff.
- If the customer's estimate of the interstate traffic on the service involved constitutes more than 10% of the total traffic on that service, the service will be provided in accordance with the applicable rules and regulations of this Tariff.
- The Telephone Company will notify its Special Access (a.k.a. BellSouth SPA) customers via letters or bill inserts of this jurisdictional rule change pursuant to FCC Decision and Order released on July 20, 1989 in CC Docket Nos. 78-72 and 80-286. By this notification, customers will be requested to review their existing and ordered services to certify the jurisdiction for their services. Customer requests to change jurisdictions received by the Telephone Company on or before May 15, 1990 will become effective on May 15, 1990. Customer requests to change jurisdictions received by the Telephone Company after May 15, 1990 will become effective on the date received.

ISSUED: JANUARY 31, 2012

EFFECTIVE: FEBRUARY 15, 2012

ACCESS SERVICE

2 - General Regulations (Cont'd)

2.3 Obligations of the Customer (Cont'd)

2.3.12 Determination of Jurisdiction of Mixed Interstate and Intrastate Special Access (a.k.a. BellSouth SPA) Service (Cont'd)

- Pursuant to FCC Decision and Order released on July 20, 1989 in CC Docket Nos. 78-72 and 80-286, customers may be required to change jurisdiction for certain Special Access (a.k.a. BellSouth SPA) services which have a termination liability. Because of the nature of the change in jurisdiction, the Telephone Company will waive application of the termination liability for a period of 90 days beginning May 15, 1990. The termination liability will be transferred with the jurisdictional change of the service.

2.3.13 Sectionalization - Trouble Reporting

The customer will be responsible for reporting troubles, sectionalized to Telephone Company facilities and/or equipment. When troubles cannot be clearly sectionalized to the Telephone Company facilities and/or equipment, the Telephone Company will test cooperatively or independently to assist in trouble sectionalization.

Responsibility for payment of additional charges will apply as set forth in Section 13.

2.3.14 Toll Free Dialing Number Reporting

For BellSouth SWA 8XX Toll Free Dialing Access Ten Digit Screening Service the customer will be responsible for reporting to the Telephone Company or directly to the Service Management System BellSouth SWA Toll Free Dialing numbers (800, 888, etc), hereinafter toll free dialing numbers, that are in service in the Telephone Company serving area and the activation date of every toll free dialing number assigned.

2.3.15 Utilization of Alternative Access Providers

When the customer of record for an access service utilizes the service(s) of an alternative access provider, it will be the obligation of the customer to monitor the actions of the alternative access provider to insure that the customer's desired service interconnections and grades of service are maintained.

2.3.16 VoIP - PSTN Traffic

This Section applies to VoIP-PSTN traffic exchanged between the Telephone Company and the Customer in time division multiplexing ("TDM") format that originates and/or terminates in Internet protocol ("IP") format. VoIP-PSTN traffic originates and/or terminates in IP format if it originates from and/or terminates to an end-user Customer of a service that requires Internet protocol-compatible Customer premises equipment. The Switched Access rate elements in this tariff for both usage and facilities apply to any VoIP-PSTN traffic.

(N)
|
(N)

ISSUED: MARCH 13, 2020

EFFECTIVE: MARCH 17, 2020

(ACCESS SERVICE)

(S)

2. General Regulations (Cont'd)

(S)

2.3 Obligations of the Customer (Cont'd)

(S)

2.3.17 Unlawful Use Traceback Obligations

(S)

Customer agrees that when it sends traffic to the Telephone Company, if it receives a Traceback Request regarding such traffic which the Telephone Company reasonably believes to be unlawful and abusive traffic, from the Telephone Company, or any Authorized Traceback Group, Customer will promptly respond to the Traceback Request in good faith. Customer agrees that its response shall indicate if it is in the call path as the Originating Provider of the calls (i.e., Customer received the calls from Customer's end user) or an intermediate Provider (i.e., Customer received the calls from another voice provider). The response shall also identify the provider from which it accepted the traffic or the end user that originated the call, as applicable. Customer agrees to provide responses to Traceback Requests to the Telephone Company or any designee, including an Authorized Traceback Group, without requiring a subpoena or other formal demand or request.

(S)

(Z)

(Z)

(S)

(S)

ISSUED: JUNE 30, 2020

EFFECTIVE: JULY 15, 2020

ACCESS SERVICE

2 - General Regulations (Cont'd)

2.4 Payment Arrangements and Credit Allowances

2.4.1 Payment of Rates, Charges and Deposits

- (A) The Telephone Company will, in order to safeguard its interests, only require a customer which has a proven history of late payments to the Telephone Company or does not have established credit to make a deposit prior to or at any time after the provision of a service to the customer to be held by the Telephone Company as a guarantee of the payment of rates and charges.

The Telephone Company will notify the customer of a deposit requirement by Certified Mail or Overnight Delivery. The customer will be required to make payment of such deposit prior to the provision of new service in those cases where the customer has not established credit with the Telephone Company, or otherwise within fifteen (15) business days of such notice for customers with existing services. Such notice period will start the day after the notice is rendered by Certified Mail or Overnight Delivery.

No such deposit will be required of a customer which is a successor of a company which has established credit and has no history of late payments to the Telephone Company. Such deposit may not exceed the actual or estimated rates and charges for the service for a two month period. The fact that a deposit has been made in no way relieves the customer from complying with the Telephone Company's regulations as to the prompt payment of bills. At such time as the provision of the service to the customer is terminated, the amount of the deposit will be credited to the customer's account and any credit balance which may remain will be refunded.

Such a deposit will be refunded or credited to the customer's account when the customer has established credit or, in any event, after the customer has established a one-year prompt payment record at any time prior to the termination of the provision of the service to the customer. In the case of a cash deposit, for the period the deposit is held by the Telephone Company, the customer will receive simple interest at the rate of 1.5% per month (.0004931 per day) or 18% annually. The rate will be calculated from the date the customer's deposit is received by the Telephone Company up to and including the date such deposit is credited to the customer's account or the date the deposit is refunded by the Telephone Company. Should a deposit be credited to the customer's account, as indicated above, no interest will accrue on the deposit from the date such deposit is credited to the customer's account.

- (B) The Telephone Company shall bill on a current basis all charges incurred by and credits due to the customer under this tariff attributable to services, including, but not limited to maintenance of service as set forth in 13.3.1 following established or discontinued during the preceding billing period. In addition, the Telephone Company shall bill in advance charges for all services to be provided during the ensuing billing period except for charges associated with service usage and for the Federal Government which will be billed in arrears.

(D) (This page filed under Transmittal No. 157)

ISSUED: JUNE 30, 2020

EFFECTIVE: JULY 15, 2020

ACCESS SERVICE

2 - General Regulations (Cont'd)

2.4 Payment Arrangements and Credit Allowances (Cont'd)

2.4.1 Payment of Rates, Charges and Deposits (Cont'd)

(B) (Cont'd)

The bill day (i.e., the billing date of a bill for a customer for Access Service under this tariff), the period of service each bill covers and the payment due date will be as follows:

- (1) For End User Access Service and Federal Universal Service (FUS) charges as set forth in Section 4 following, and BellSouth Equal Access Subscription Service as set forth in Section 13 following, the Telephone Company will establish a bill day each month for each end user account. The bill will cover End User Access Service charges for the ensuing billing period except for End User Access Service for the Federal Government, which will be billed in arrears. Any applicable subscription charges, any known unbilled charges for prior periods and any known unbilled adjustments for prior periods for End User Access Service and BellSouth Equal Access Subscription Service will be applied to this bill. Such bills are due when rendered.
- (2) For End User Access Service and Federal Universal Service charges, and BellSouth Equal Access Subscription Service, the Telephone Company will establish a bill day each month for each customer account. The bill will cover non-usage sensitive service charges for the ensuing billing period or which the bill is rendered, any known unbilled non-usage sensitive charges for prior periods and unbilled usage charges for the period after the last bill day through the current bill day. Any known unbilled usage charges for prior periods and any known unbilled adjustments will be applied to this bill. Payment for such bills is due as set forth in (3) following. If payment is not received by the payment due date, as set forth in (3) following in immediately available funds, a late payment penalty will apply as set forth in (3) following.

ISSUED: March 9, 2000

EFFECTIVE: MARCH 24, 2000

ACCESS SERVICE

2 - General Regulations (Cont'd)

2.4 Payment Arrangements and Credit Allowances (Cont'd)

2.4.1 Payment of Rates, Charges and Deposits (Cont'd)

(B) (Cont'd)

(3) Payment Due Date

- (a) All bills dated as set forth in (2) preceding for service, other than End User Access Service and BellSouth Equal Access Subscription Service, provided to the customer by the Telephone Company are due on the payment due date. The payment due date is the date which is 31 days after the bill day, or by the next bill date (i.e., same date in the following month as the bill date), whichever is the shortest interval except as provided herein, and are payable in immediately available funds. If such payment due date would cause the payment to be due on a Saturday, Sunday or federal observed Holiday (e.g., New Year's Day, Birthday of Martin Luther King, Jr., Washington's Birthday, Memorial Day, Independence Day, Labor Day, Columbus Day, Veterans Day, Thanksgiving Day, Christmas Day), payment for such bills will be due from the customer as follows:

If such payment due date falls on a Sunday or on a federal observed Holiday which is observed on a Monday, the payment due date shall be the first non-federal observed Holiday day following such Sunday or federal observed Holiday. If such payment due date falls on a Saturday or on a federal observed Holiday which is observed on Tuesday, Wednesday, Thursday or Friday, the payment due date shall be the last non-federal observed Holiday day preceding such Saturday or federal observed Holiday.

Payment for Federal Government customers will be in compliance with the Federal Acquisition Regulations Clause 52.232-25 - Prompt Payment.

- (b) Further, if any portion of the payment is received by the Telephone Company after the payment due date as set forth in (a) preceding, or if any portion of the payment is received by the Telephone Company in funds which are not immediately available to the Telephone Company, then a late payment penalty may be due to the Telephone Company. The late payment penalty shall be the portion of the payment not received by the payment due date times a late factor. The late factor shall be simple interest at the rate of 1.5% per month (.0004931 per day) or 18% annually. The late payment for Federal Government customers shall be in compliance with the Federal Acquisition Regulations Clause 52.232-25 - Prompt Payment.

ISSUED: APRIL 5, 2012

EFFECTIVE: APRIL 20, 2012

ACCESS SERVICE

2 - General Regulations (Cont'd)

2.4 Payment Arrangements and Credit Allowances (Cont'd)

2.4.1 Payment of Rates, Charges and Deposits (Cont'd)

(B) (Cont'd)

(3) (Cont'd)

(c) Payment of Rates, Charges and Deposits

In the event of a billing dispute, the customer must submit a documented claim for the disputed amount. If the dispute is submitted on or before the payment due date or within 90 days after the payment due date and the disputed amount is paid prior to resolution of the dispute, any interest credits due the customer upon resolution of the dispute shall be calculated from the date of the overpayment to the resolution date. If the dispute is submitted more than 90 days after the payment due date and the disputed amount is paid prior to resolution of the dispute, any interest credits due the customer upon resolution of the dispute shall be calculated from the dispute date or the date the payment is made, whichever occurs later, to the resolution date. The Telephone Company will resolve the dispute and assess interest credits or late payment penalties to the customer as follows.

If the dispute is resolved in favor of the Telephone Company and the customer has paid the disputed amount on or before the payment due date, no credits or late payment penalties will apply to the disputed amount.

If the dispute is resolved in favor of the Telephone Company and the customer has withheld the disputed amount, any payments withheld pending settlement of the dispute shall be subject to the late payment penalty as set forth in (b) preceding.

If the dispute is resolved in favor of the customer and the customer has withheld the disputed amount, no credits or late payment penalties will apply to the disputed amount.

If the dispute is resolved in favor of the customer and the customer has paid the disputed amount, the customer will receive a credit from the Telephone Company for the disputed amount times a penalty factor as set forth preceding. The penalty factor shall be simple interest (I) at the rate of 1.5% per month (.0004931 per day) or 18% (I) annually.

If a customer's traffic terminates to an end office via an alternative tandem service provider (TSP), any terminating

ISSUED: JUNE 16, 2011

EFFECTIVE: JULY 1, 2011

ACCESS SERVICE

2 - General Regulations (Cont'd)

2.4 Payment Arrangements and Credit Allowances (Cont'd)

2.4.1 Payment of Rates, Charges and Deposits (Cont'd)

(B) (Cont'd)

(3) (Cont'd)

(c) Payment of Rates, Charges and Deposits (Cont'd)

usage dispute for that end office must identify the quantity of MOUs the customer's records indicate to be terminated via an alternative TSP.

Upon receipt of the dispute involving usage terminated via an alternative TSP, the Telephone Company will verify that the disputed bill accurately represents the information provided to the Telephone Company pursuant to 6.6.5 following, within 15 days of receipt of a dispute notification.

If the billing agrees with the billing data received pursuant to 6.6.5 following, the Telephone Company will refer the dispute to the entity providing the billing data information within 16 days from the date the dispute was received.

The provider of the billing data information will investigate the claim and reply to the Telephone Company within 15 days of the referral.

The provider of the billing data information, the customer and the Telephone Company will work cooperatively to resolve any remaining discrepancies.

If the entity providing the billing data information fails to cooperate with the Telephone Company to resolve billing disputes involving usage billed based on the billing data information received, the Telephone Company may refuse to accept future billing data information and bill the full terminating charges for all usage to the alternative TSP.

The terms and conditions in 2.4.1(B)(3)(c) preceding still apply except for the following:

If the Telephone Company accurately billed the usage as contained in the billing data information provided to it, the Telephone Company will not be liable for any interest due the customer for overpayment if the dispute is resolved in the customer's favor.

ISSUED: JUNE 16, 2011

EFFECTIVE: JULY 1, 2011

ACCESS SERVICE

2 - General Regulations (Cont'd)

2.4 Payment Arrangements and Credit Allowances (Cont'd)

2.4.1 Payment of Rates, Charges and Deposits (Cont'd)

- (C) Adjustments for the quantities of services established or discontinued in any billing period beyond the minimum period set forth for services in other sections of this tariff will be prorated based on the number of days the customer had service during the billing period times 1/30th the monthly rate. Billing for service begins on the day following the date of installation and shall accrue through and including the day service is discontinued. The Telephone Company will, upon request and if available, furnish such detailed information as may reasonably be required for verification of any bill, including information relative to the development of the subscriber line ratio.
- (D) When a rate as set forth in this tariff is shown to more than two decimal places, the charges will be determined using the rate shown. The resulting amount will then be rounded to the nearest penny (i.e., rounded to two decimal places).
- (E) When more than one copy of a customer bill for services provided under the provisions of this tariff is furnished to the customer, an additional charge applies for each additional copy of the bill as set forth in 13.3.6 following.
- (F) The dispute date is the date the customer presents sufficient documentation to support the claim. Sufficient documentation consists of the following information, where such information is relevant to the dispute and reasonably available to the customer:

(1) Special Access (a.k.a. BellSouth SPA)

The nature of the dispute (i.e., incorrect rate, incorrect circuit type etc.), including the basis for the customer's belief that the bill is incorrect.

The billing account number(s) assigned by the Telephone Company.

The amount of money in dispute.

The date of the bill in dispute.

ISSUED: JUNE 16, 2011

EFFECTIVE: JULY 1, 2011

ACCESS SERVICE

2 - General Regulations (Cont'd)

2.4 Payment Arrangements and Credit Allowances (Cont'd)

2.4.1 Payment of Rates, Charges and Deposits (Cont'd)

(F) (Cont'd)

(2) BellSouth SWA (Non-Usage)

The nature of the dispute (i.e., incorrect rate etc.), including the basis for the customer's belief that the bill is incorrect.

The billing account number(s) assigned by the Telephone Company.

The amount of money in dispute.

The date of the bill in dispute.

(3) BellSouth SWA (Usage)

The nature of the dispute (i.e., incorrect rate, incorrect minutes of use, etc.), including the basis for the customer's belief that the bill is incorrect.

The type of usage (i.e., originating or terminating).

The Telephone Company end office where the minutes of use originated or terminated (if applicable).

The number of minutes in dispute.

The billing account number(s) assigned by the Telephone Company.

The amount of money in dispute.

The date of the bill.

ISSUED: JUNE 16, 2011

EFFECTIVE: JULY 1, 2011

ACCESS SERVICE

2 - General Regulations (Cont'd)

2.4 Payment Arrangements and Credit Allowances (Cont'd)

2.4.1 Payment of Rates, Charges and Deposits (Cont'd)

- (G) The Telephone Company and the customer shall work cooperatively to resolve the dispute.

If additional information from the customer would assist in resolving the dispute, the customer may be requested to provide additional information relevant to the dispute and reasonably available to the customer. This data may include, but is not limited to summarized usage data by time of day. The request for such additional information shall not affect the dispute date established pursuant to 2.4.1(F) preceding.

- (H) For purposes of 2.4.1(B)(3)(c), the resolution date is the date on which the Telephone Company completes the investigation of the dispute, and the Telephone Company's service representative notifies the customer of the disposition and notes the customer's account or when the Telephone Company forwards the amount of credit to the customer, depending upon customer preference.

- (I) At the option of the customer, all nonrecurring charges associated with a Standard or Negotiated Interval Access Order may be billed over a three month period subject to the following:

- 50% of the total nonrecurring charges will be billed in the first monthly billing period after the charges are incurred, and 25% of the total nonrecurring charges plus an Extended Billing Plan Charge will be billed in each of the following two monthly billing periods.
- The Extended Billing Plan Charge is calculated at a rate of 1.0% per month or 12% annually, on the remaining balance of the nonrecurring charges.
- The customer must request extended billing on or before the Application Date as set forth in 5.1.1. following for a Standard or Negotiated Interval Access Order.
- If the customer disconnects service before the expiration of the plan period, all unbilled charges plus the Extended Billing Plan Charge, if applicable, will be included in the final bill rendered.

ISSUED: DECEMBER 16, 2022

EFFECTIVE: JANUARY 1, 2023

ACCESS SERVICE
2 - General Regulations (Cont'd)

2.4 Payment Arrangements and Credit Allowances (Cont'd)

2.4.1 Payment of Rates, Charges and Deposits (Cont'd)

(I) (Cont'd)

- This payment arrangement is not available for Daily Program Audio⁽¹⁾ (a.k.a. BellSouth SPA Program Audio) and Daily Video (a.k.a. BellSouth SPA Video). (N)
- If the customer fails to make any of the payments on the payment due date as set forth in 2.4.1(B)(3)(a) preceding, late payment charges as specified in 2.4.1(B)(3)(b) preceding will apply.

(J) When utility or telecommunications assessments, franchise fees, or privilege, license, occupational, excise, or other similar taxes or fees, based on interstate receipts are imposed by certain taxing jurisdictions upon the Telephone Company, the amounts of such taxes or fees will be billed to Customers in such a taxing jurisdiction on a prorated basis except where such Customers are exempt from the tax. The amount of charge that is prorated to each Customer's bill is determined by the interstate telecommunications services provided to and billed to a Customer service location in such a taxing jurisdiction with the aggregate of such charges equal to the amount of the tax or fee imposed upon or passed on to the Telephone Company. The taxing jurisdictions in which the charges will be applicable are:

<u>Jurisdiction</u>	<u>Tax Factors</u>
State of Kentucky (Gross Revenues Tax Surcharge)	1.31%
South Carolina municipalities listed below	1%
Aiken	
Allendale	
Anderson	
Arcadia Lakes	
Bamberg	
Barnwell	
Batesburg/Leesville	
Belton	
Bennettsville	
Blacksburg	
Blackville	
Blenheim	
Blythewood	
Burnettown	
Calhoun Falls	
Camden	
Carlisle	
Cayce	
Central	
Central Pacolet	
Chapin	

(1) Program Audio is discontinued and no longer available in this publication (see WC Dkt. 19-238). (N)

ISSUED: JUNE 30, 2020

EFFECTIVE: JULY 15, 2020

ACCESS SERVICE
2 - General Regulations

2.4 Payment Arrangements and Credit Allowances (Cont'd)

2.4.1 Payment of Rates, Charges and Deposits (Cont'd)

(J) Cont'd

<u>Jurisdiction</u>	<u>Tax Factor</u>
South Carolina municipalities listed below	1%
Charleston	
Cheraw	
Clemson	
Clinton	
Clio	
Clover	
Columbia	
Cope	
Cordova	
Cowpens	
Darlington	
Denmark	
Dillon	
Duncan	
Easley	
Eastover	
Edgefield	
Edisto Beach	
Elgin	
Florence	
Folly Beach	
Forest Acres	
Fountain Inn	
Gaffney	
Gaston	
Goose Creek	
Govan	
Greenville	
Greer	
Hanahan	
Hartsville	
Hickory Grove	
Hilda	
Hollywood	
Honea Path	
Irmo	
Isle of Palms	
Iva	
Johnston	
Jonesville	
Kiawah Island	

ISSUED: JUNE 30, 2020

EFFECTIVE: JULY 15, 2020

ACCESS SERVICE

2 - General Regulations (Cont'd)

2.4 Payment Arrangements and Credit Allowances (Cont'd)

2.4.1 Payment of Rates, Charges and Deposits (Cont'd)

(J) Cont'd

<u>Jurisdiction</u>	<u>Tax Factor</u>
South Carolina municipalities listed below	1%
Lake View	
Landrum	
Latta	
Lexington	
Liberty	
Lincolnton	
Little Mountain	
Lyman	
Marion	
Mauldin	
McColl	
McConells	
Monetta	

ISSUED: JUNE 30, 2020

EFFECTIVE: JULY 15, 2020

ACCESS SERVICE
2 - General Regulations

2.4 Payment Arrangements and Credit Allowances (Cont'd)

2.4.1 Payment of Rates, Charges and Deposits (Cont'd)

(J) Cont'd

<u>Jurisdiction</u>	<u>Tax Factor</u>
South Carolina municipalities listed below	1%
Mt. Pleasant	
Mullins	
Myrtle Beach	
New Ellenton	
Newberry	
Nichols	
Norris	
North Augusta	
North Charleston	
Orangeburg	
Pacolet	
Peak	
Pelzer	
Pendleton	
Pickens	
Pine Ridge	
Pomaria	
Prosperity	
Quinby	
Ravenel	
Reevesville	
Reidville	
Ridgeland	
Ridgeville	
Rowesville	
Salem	
Salley	
Seabrook Island	
Sellers	
Seneca	
Sharon	
Six Mile	

ISSUED: JUNE 30, 2020

EFFECTIVE: JULY 15, 2020

ACCESS SERVICE
2 - General Regulations

2.4 Payment Arrangements and Credit Allowances (Cont'd)

2.4.1 Payment of Rates, Charges and Deposits (Cont'd)

(J) Cont'd

<u>Jurisdiction</u>	<u>Tax Factor</u>
South Carolina municipalities listed below	1%
Smyrna	
Snelling	
Society Hill	
South Congaree	
Spartanburg	
Springdale	
Springfield	
St. George	
Stuckey	
Sullivan's Island	
Summerville	
Tatum	
Timmons ville	
Travelers Rest	
Trenton	

ISSUED: JUNE 30, 2020

EFFECTIVE: JULY 15, 2020

ACCESS SERVICE
2 - General Regulations

2.4 Payment Arrangements and Credit Allowances (Cont'd)

2.4.1 Payment of Rates, Charges and Deposits (Cont'd)

(J) Cont'd

<u>Jurisdiction</u>	<u>Tax Factor</u>
South Carolina municipalities listed below	1%
Ulmer	
Union	
Walhalla	
Wellford	
West Columbia	
West Pelzer	
West Union	
Westminister	
Whitmire	
Williamston	
York	

2.4.2 Minimum Periods

The minimum period for which services are provided and for which rates and charges are applicable is one month except for those services set forth in Sections 5.6(C), 6.7.20, 6.7.21, 6.7.22, 7.4.32, 7.4.4, 7.4.13.2, 10.6.1 and 13.3.5(C)(1)(b), (c) and (d) of this Tariff.

The minimum period for which service is provided and for which rates and charges are applicable for a Specialized Service or Arrangement provided on an individual case basis as set forth in Section 12 following, is one month unless a different minimum period is established with the individual case filing.

ISSUED: JUNE 16, 2011

EFFECTIVE: JULY 1, 2011

ACCESS SERVICE

2 - General Regulations (Cont'd)

2.4 Payment Arrangements and Credit Allowances (Cont'd)

2.4.2 Minimum Periods (Cont'd)

When a service is discontinued prior to the expiration of the minimum period, charges are applicable whether the service is used or not as follows:

- (A) When a service with a one month minimum period is discontinued prior to the expiration of the minimum period, a one month charge will apply at the rate level in effect at the time service is discontinued.
- (B) Except for High Capacity (a.k.a. BellSouth SPA High Capacity) Individual Case Basis (ICB) services and associated channelization listed in Section 7 and Section 12, when a service with a minimum period greater than one month is discontinued prior to the expiration of the minimum period, the applicable charge will be the lesser of (1) the Telephone Company's total nonrecoverable costs less the net salvage value for the discontinued service or (2) the total monthly charges, at the rate level in effect at the time service is discontinued, for the remainder of the minimum period. For High Capacity (a.k.a. BellSouth SPA High Capacity) Individual Case Basis Services the applicable charge is specified in the Individual Case Basis filing.
- (C) When a customer requests the complete termination of a Special Access (a.k.a. BellSouth SPA) Voice Grade (a.k.a. BellSouth SPA DSO VG) Rate Stability Plan prior to the expiration date of the selected service commitment period, a Termination Liability Charge as specified in 7.4.13.5(B) following will apply.
- (D) For Special Access (a.k.a. BellSouth SPA) DS1 (a.k.a. BellSouth SPA DS1) service provided under a Federal Government Transport Plan (FGTP) arrangement, minimum period charges are as set forth in 10.6.1(F) following.

2.4.3 Cancellation of an Order for Service

Provisions for the cancellation of an Access Order for BellSouth SWA or Special Access service, (a.k.a. BellSouth SPA) are set forth in 5.4 following.

2.4.4 Credit Allowance for Service Interruptions

(A) General

A service is considered interrupted when it becomes unusable to the customer because of a failure of a facility component used to furnish service under this tariff or in the event that the protective controls applied by the Telephone Company result in the loss of use of the service by the customer as set forth in 6.5.1 following. An interruption period starts when the customer reports the interruption to the Telephone Company, and ends when the service is operative.

ISSUED: MARCH 2, 2023

EFFECTIVE: MARCH 17, 2023

ACCESS SERVICE
2 - General Regulations (Cont'd)

2.4 Payment Arrangements and Credit Allowances (Cont'd)

2.4.4 Credit Allowance for Service Interruptions (Cont'd)

(B) When a Credit Allowance Applies

In case of an interruption to any service, allowance for the period of interruption, if not due to the negligence of the customer, shall be as follows:

- (1) For BellSouth SWA Dedicated Interoffice Channels, Channelization Equipment and Switched Local Channels, Dedicated End Office Trunk Port Service and Dedicated Tandem Trunk Port Service Special Access (a.k.a. BellSouth SPA) services other than BellSouth Dedicated Ring, SMARTPath service (a.k.a. BellSouth SPA DS1 Shared Ring), and SMARTPath DS3 Transport service (a.k.a. BellSouth SPA DS3 Shared Ring), LightGate service (a.k.a. BellSouth SPA Point to Point Network), DS1 (a.k.a. BellSouth SPA DS1) service, BellSouth DS1 Diverse Service, Program Audio⁽¹⁾ (a.k.a. BellSouth SPA Program Audio), Broadcast Quality Video (a.k.a. BellSouth SPA Broadcast Quality Video) services, Intra-Office Collocation Cross Connect Service, Physical Access Cross Connect Service and Virtual Access Cross Connect Service, no credit shall be allowed for an interruption of less than 30 minutes. The customer shall be credited for an interruption of 30 minutes or more at the rate of 1/1440 of the monthly charges for the facility or service for each period of 30 minutes or major fraction thereof that the interruption continues.

The credits will apply no more than once per month and the total of all credits, including those provided in other sections of this Tariff, shall not exceed the monthly rate for the service. The monthly charges used to determine the credit shall be as follows:

- (a) The monthly charge shall be the total of all the monthly rate element charges associated with the highest level inoperative channelized service:
For BellSouth SWA Transport: BellSouth SWA Local Channel, Dedicated End Office Trunk Port Service and Dedicated Tandem Trunk Port Service, BellSouth SWA Dedicated Interoffice Channel, Channelization Equipment (if applicable) and any Optional Features and Functions.
For Special (a.k.a. BellSouth SPA) two-point services: two Local Channels, Interoffice Channel, and Optional Features and Functions. (T)
- (b) For multipoint services, the monthly charge shall be only the total of all the monthly rate element charges associated with the highest level channelized service for that portion of the service that is inoperative (i.e., a local channel per customer premises, interoffice channel, and optional features, and functions). (T)
- (c) For Special Access (a.k.a. BellSouth SPA) channelized services, the monthly charge shall be the total of all the monthly rate element charges associated with that portion of the highest level channelized service that is inoperative.

⁽¹⁾ Program Audio is discontinued and no longer available in this publication (see WC Dkt. 19-238).

ISSUED: MARCH 2, 2023

EFFECTIVE: MARCH 17, 2023

ACCESS SERVICE
2 - General Regulations (Cont'd)

2.4 Payment Arrangements and Credit Allowances (Cont'd)

2.4.4 Credit Allowance for Service Interruptions (Cont'd)

(B) When a Credit Allowance Applies (Cont'd)

(1) (Cont'd)

(c) (Cont'd)

When the facility which is channelized or the Basic Channelization System itself is inoperative, the monthly charge shall be the total of all the monthly rate element charges associated with the highest level channelized service (i.e., the local channel, interoffice channel, central office channel interface(s), and any optional features and functions, including the Basic Channelization System on the facility to the Hub. When the service which rides a channel of the channelized facility is inoperative (assuming the highest level channelized service is still operative) the monthly charge shall be the total of all the monthly rate element charges associated with that portion of the lower level inoperative service from the Hub to a customer premises (i.e., local channels, interoffice channel, central office channel interface(s), and optional features and functions). For channelized service ordered under the Shared Network Arrangement, certain record keeping complexities necessitate that the host subscriber as well as each service user notify Telephone Company of any service outage in order to receive a credit allowance.

(T)

(d) For BellSouth SWA channelized services, the monthly charge shall be the total of all monthly rate element charges associated with that portion of the highest level channelized service that is inoperative. When the facility which is channelized or the Basic Channelization System itself is inoperative, the monthly charge shall be the total of all the monthly rate element charges associated with the highest level channelized service (e.g., the Switched Local Channel, Switched Interoffice Channels, Channelization Equipment, including the Basic Channelization System on the facility to the Hub, if applicable).

(T)

(e) For SMARTPath services (a.k.a. BellSouth SPA Shared Ring) and SMARTPath DS3 Transport service (a.k.a. BellSouth SPA DS3 Shared Ring), the monthly charge shall be the total of all the monthly rate element charges associated with the highest level inoperative channelized service (e.g., SMARTPath Area Connection and SMARTPath Area Junction).

(f) For Intra-Office Collocation Cross Connect, Physical Access Cross Connect, and Virtual Access Cross Connect elements specified in Section 13 of this Tariff, the monthly charge shall be that associated with the specific cross connect that is inoperative.

(g) For BellSouth SWA service, BellSouth Directory Assistance Access service, and BellSouth Line Information Data Base Access service usage sensitive rate elements, no credit shall be allowed for an interruption of less than 24 hours. The customer shall be credited for an interruption of 24 hours or more at the rate applicable to the service involved, for each period of 24 hours or major fraction thereof that the interruption continues. In the case of service billed based upon actual usage, no credit allowance is applicable.

(M)

(h) The credit allowance(s) for an interruption or for a series of interruptions shall not exceed (a) the sum of the monthly charges for the affected services; or (b) the assumed minutes of use charge.

(M) (G)
(M) (D)

(M) Material now appearing on this page previously appeared on Page 2-50.

(N)

ISSUED: MARCH 2, 2023

EFFECTIVE: MARCH 17, 2023

ACCESS SERVICE

2 - General Regulations (Cont'd)

2.4 Payment Arrangements and Credit Allowances (Cont'd)

2.4.4 Credit Allowance for Service Interruptions (Cont'd)

(B) When a Credit Allowance Applies (Cont'd)

Quick Reference Service Outage Table	
Active Services	Section Reference
BellSouth Administrative Management Service	2.4.4(B)(5)
BellSouth Wavelength SWA Channel Service Components and BellSouth Channel Service	2.4.4(B)(15)
Broadcast Quality Video	2.4.4(B)(2)
DS1 Diverse Access	2.4.4(B)(12)
DS1 Special Access subject to a current term plan in effect as of 4/4/2015	2.4.4(B)(7)
DS1 Special Access subject to a circuit term plan initiated or renewed after 4/4/2015 or being provided on a month-to-month basis	2.4.4(B)(16)
LightGate Service, excluding DS1 Channel Interfaces and services subject to a term plan renewed on or after 3/17/2023 or being provided on a month-to-month basis	2.4.4(B)(8)
LightGate Service subject to a term plan renewed on or after 3/17/2023 or being provided on a month-to-month basis	2.4.4(B)(16)
LightGate Service DS1 Channel Interfaces	2.4.4(B)(7)
SMARTPath Service	2.4.4(B)(6)
Specialized Service or Arrangements provided under Section 12	2.4.4(B)(4)
Switched Access DS1	2.4.4(B)(10)
Switched Access DS3	2.4.4(B)(11)
Grandfathered/Discontinued Services	
Digital Data Access	2.4.4(B)(3)
Fast Packet Services	2.4.4(B)(13)
High Capacity (a.k.a. BellSouth SPA High Capacity) DS1 HC1	2.4.4(B)(3)
Program Audio	2.4.4(B)(2)

(2) For Program Audio⁽¹⁾ (a.k.a. BellSouth SPA Program Audio) and Broadcast Quality Video (a.k.a. BellSouth SPA Broadcast Quality Video) Special Access services (a.k.a. BellSouth SPA), no credit shall be allowed for an interruption of less than 30 seconds. The customer shall be credited for an interruption of 30 seconds or more as follows:

⁽¹⁾ Program Audio is discontinued and no longer available in this publication (see WC Dkt. 19-238).

(M) Material previously appearing on this page now appears on Page 2-50.

ISSUED: MARCH 2, 2023

EFFECTIVE: MARCH 17, 2023

ACCESS SERVICE

2 - General Regulations (Cont'd)

2.4 Payment Arrangements and Credit Allowances (Cont'd)

2.4.4 Credit Allowance for Service Interruptions (Cont'd)

(B) When a Credit Allowance Applies (Cont'd)

(2) (Cont'd)

- (a) For two-point services, when monthly rates are applicable, the credit shall be at the rate of 1/8640 of the monthly charges for the service for each period of 5 minutes or major fraction thereof that the interruption continues. (M1)
- (b) For two-point services, when daily rates are applicable, the credit shall be at the rate of 1/288 of the daily charges for the service for each period of 5 minutes or major fraction thereof that the interruption continues.
- (c) For multipoint services, when monthly rates are applicable, the credit shall be at the rate of 1/8640 of the monthly charges for all channel terminations, channel mileages, and optional features and functions that are inoperative for each period of 5 minutes or major fraction thereof that the interruption continues. (T) (M1)
- (d) For multipoint services, when daily rates are applicable, the credit shall be at the daily rate of 1/288 of the daily charges for each channel termination, channel mileage, and optional features and functions that is inoperative for each period of 5 minutes or major fraction thereof that the interruption continues. (T)
- (e) For multipoint services, the credit for the monthly or daily charges includes the charges for the distribution amplifier only when the distribution amplifier is inoperative.
- (f) When two or more interruptions occur during a period of 5 consecutive minutes, such multiple interruptions shall be considered as one interruption.

- (3) For certain Special Access (a.k.a. BellSouth SPA) services (Digital Data Access (a.k.a. BellSouth SPA DS0 Digital Data), DA1-4; and High Capacity (a.k.a. BellSouth SPA High Capacity) HC1, any period during which the error performance is below that specified for the service will be considered as an interruption. (M2) (T) (T)

(M1) Material now appearing on this page previously appeared on Page 2-49. (N)
(M2) Material previously appearing on this page now appears on Page 2-48. (N)

ISSUED: MARCH 2, 2023

EFFECTIVE: MARCH 17, 2023

ACCESS SERVICE

2 - General Regulations (Cont'd)

2.4 Payment Arrangements and Credit Allowances (Cont'd)

2.4.4 Credit Allowance for Service Interruptions (Cont'd)

(B) When a Credit Allowance Applies (Cont'd)

- (4) Service interruptions for Specialized Service or Arrangements provided under the provisions of Section 12 following shall be administered in the same manner as those set forth in 2.4.4 unless other regulations are specified with the Individual Case Basis filing. (T)
- (5) Service interruption for BellSouth Administrative Management Service shall be administered in the same manner as set forth in 13.3.10(C) following. (T)

ISSUED: MARCH 2, 2023

EFFECTIVE: MARCH 17, 2023

ACCESS SERVICE

2 - General Regulations (Cont'd)

2.4 Payment Arrangements and Credit Allowances (Cont'd)

2.4.4 Credit Allowance for Service Interruptions (Cont'd)

(B) When a Credit Allowance Applies (Cont'd)

- (6) For SMARTPath service (a.k.a. BellSouth SPA Shared Ring), and SMARTPath DS3 Transport service (a.k.a. BellSouth SPA DS3 Shared Ring) rate elements, failure by the Telephone Company to meet the performance guarantee described in Sections 7.2.13(C)(2) and 7.2.14(C)(1) of this Tariff, respectively, will prompt a credit equal to 1440/1440 for effected SMARTPath service (a.k.a. BellSouth SPA DS1 Shared Ring), or SMARTPath DS3 Transport service (a.k.a. BellSouth SPA DS3 Shared Ring), rate elements. A customer request for credit will not be required. The credit will be applied through normal administrative processes and the dollar amount will be reflected on the customer's bill. The credit will apply no more than once per billing period. This credit is in addition to those provided in 2.4.4(B)(1) preceding. The combined total of the credit allowance during a month for failure to meet the performance guarantee in Section 7.2.13(C)(2) or 7.2.14(C)(1), as applicable, and the credit for service interruption contained in Section 2.4.4(B)(1) shall not exceed the monthly rate for the highest level inoperative channelized service. (T)
- (7) The Credit Allowance for Service Interruptions, as described in Section 2.2.4(B)(7), applies only to DS1 Special Access circuits purchased under a CSPP or a TPP in effect as of April 4, 2015. For DS1 Special Access circuit purchased on a month-to-month basis, including those circuits selected for an ACP discount, the Credit Allowance for Service Interruptions will only apply to circuits in effect as of April 4, 2015. Thereafter, the Service Assurance Warranty (SAW), as described in Section 2.4.4(B)(16), will apply. (T)(D)

Credit allowances for service interruptions on DS1 Special Access (a.k.a. BellSouth SPA DS1) service (including DS1 Alternate Serving Wire Center service and LightGate service (a.k.a. BellSouth SPA Point to Point Network) DS1 channel interfaces will be based on (T)

ISSUED: MARCH 2, 2023

EFFECTIVE: MARCH 17, 2023

ACCESS SERVICE

2 - General Regulations (Cont'd)

2.4 Payment Arrangements and Credit Allowances (Cont'd)

2.4.4 Credit Allowance for Service Interruptions (Cont'd)

(B) When a Credit Allowance Applies (Cont'd)

(7) (Cont'd)

(T)

the wire center group assignment of the customer's serving wire center, (see Group 1 wire Center list following). For DS1 Special Access (a.k.a. BellSouth SPA DS1) facilities assigned to Group 1 wire centers, the customer shall be credited at the rate of 1440/1440 for service interruptions of one minute or more. Special Access DS1 (a.k.a. BellSouth SPA DS1) customers with facilities assigned to Group 2 wire centers, (all other wire centers not included in Group 1) shall be credited for interruptions of more than 30 minutes but less than or equal to 210 minutes based on the credit allowance schedule following. For service interruptions of 211 minutes or more the customer shall receive a credit of 1440/1440 of the monthly rate. Credit allowances for DS1 Special Access (a.k.a. BellSouth SPA DS1) service interruptions involving more than one wire center group will be based on the respective local channel wire center rate and the highest interoffice channel mileage rate used in provisioning the service. Ratcheting, to account for BellSouth SWA services, will be applied to DS1 Special Access (a.k.a. BellSouth SPA DS1) service interruption credits. Credit allowance limitations shall be in accordance with Section 2.4.4(B)(1) preceding.

(T)

Credit Allowance Schedule
Group Wire Centers

<u>Interruption Period</u>	<u>Credit Per Interruption</u>
<u>30 Minutes to 150 Minutes – All</u>	360/1440
<u>151 Minutes to 210 Minutes – All</u>	720/1440
<u>211 Minutes or More – All</u>	1440/1440

(T)

(T)

(T)

The provisions of this subsection do not apply to BellSouth DS1 Diverse service.

ISSUED: MARCH 2, 2023

EFFECTIVE: MARCH 17, 2023

ACCESS SERVICE

2 - General Regulations (Cont'd)

2.4 Payment Arrangements and Credit Allowances (Cont'd)

2.4.4 Credit Allowance for Service Interruptions (Cont'd)

(B) When a Credit Allowance Applies (Cont'd)

(7) (Cont'd)

(T)

BELLSOUTH GROUP 1 WIRE CENTERS

ATLNGAAC	BRHMALOM	CLMASCSU	JCSNMSCP
ATLNGAAD	BRHMALOX	CLMASCSW	JCSNMSMB
ATLNGABH	BRHMALRC	COCYFL13	JCSNMSNR
ATLNGABU	BRHMALTA	DNWDGAMA	JCSNMSPC
ATLNGACD	BRHMALVA	DRBHFLMA	JCSNMSTR
ATLNGACS	BRHMALWE	FTLDFLAP	JCVLFLAR
ATLNGAEL	BRHMALWL	FTLDFLCR	JCVLFLBW
ATLNGAEP	BYBHFLMA	FTLDFLCY	JCVLFLCL
ATLNGAFP	CHMBGAMA	FTLDFLFT	JCVLFLFC
ATLNGAGC	CHRLNCBO	FTLDFLJA	JCVLFLIA
ATLNGAGR	CHRLNCCA	FTLDFLMA	JCVLFLJT
ATLNGAHR	CHRLNCCE	FTLDFLOA	JCVLFLLF
ATLNGAIC	CHRLNCCR	FTLDFLPL	JCVLFLNO
ATLNGALA	CHRLNCDE	FTLDFLSG	JCVLFLOW
ATLNGANW	CHRLNCER	FTLDFLSU	JCVLFLPP
ATLNGAPP	CHRLNCLP	FTLDFLWN	JCVLFLRV
ATLNGASS	CHRLNCLX	GNBONCAP	JCVLFLSJ
ATLNGATH	CHRLNCMI	GNBONCAS	JCVLFLSM
ATLNGAUY	CHRLNCMO	GNBONCEU	JCVLFLWC
ATLNGAWD	CHRLNCOD	GNBONCHO	LKWOFLAJ
ATLNGAWE	CHRLNCRE	GNBONCLA	LLBNGAMA
BCRTFLBT	CHRLNCSH	GNBONCMC	LSVLKY26
BCRTFLMA	CHRLNCTH	GNBONCPG	LSVLKY53
BCRTFLSA	CHALNCUN	GRNRNCJB	LSVLKYAN
BRHMALBH	CLMASCAR	GTWSTNSW	LSVLKYAP
BRHMALCH	CLMASCBO	HLWDFLHA	LSVLKYBE
BRHMALCP	CLMASCCH	HLWDFLMA	LSVLKYBR
BRHMALEL	CLMASCDF	HLWDFLPE	LSVLKYCS
BRHMALEN	CLMASCMI	HLWDFLWH	LSVLKYCW
BRHMALEW	CLMASCPA	JCBHFLAB	LSVLKYFC
BRHMALFO	CLMASCSA	JCBHFLMA	LSVLKYHA
BRHMALFS	CLMASCSC	JCBHFLSP	LSVLKYJT
BRHMALHW	CLMASC SH	JCSNMSBL	LSVLKYOA
BRHMALMT	CLMASC SN	JCSNMSCB	

ISSUED: MARCH 2, 2023

EFFECTIVE: MARCH 17, 2023

ACCESS SERVICE

2 - General Regulations (Cont'd)

2.4 Payment Arrangements and Credit Allowances (Cont'd)

2.4.4 Credit Allowance for Service Interruptions (Cont'd)

(B) When a Credit Allowance Applies (Cont'd)

(7) (Cont'd)

(T)

BELLSOUTH GROUP 1 WIRE CENTERS

LSVLKYSH	MMPHTNCK	NSVLTNCD	ORLDFLSA
LSVLKYSL	MMPHTNCT	NSVLTNCH	PMBHFLFE
LSVLKYSM	MMPHTNEL	NSVLTNDO	PMBHFLMA
LSVLKYTS	MMPHTNFR	NSVLTNGH	PMBHFLNP
LSVLKYVS	MMPHTNGT	NSVLTNHH	PMBHFLTA
LSVLKYWE	MMPHTNHP	NSVLTNIN	RLGHNCDU
MIAMFLAE	MMPHTNMA	NSVLTNMC	RLGHNCGA
MIAMFLAF	MMPHTNMT	NSVLTNMT	RLGHNCGL
MIAMFLAL	MMPHTNOA	NSVLTNST	RLGHNCHO
MIAMFLAP	MMPHTNSL	NSVLTNUN	RLGHNCJO
MIAMFLBA	MMPHTNST	NSVLTNWC	RLGHNCMO
MIAMFLBC	MMPHTNWW	NSVLTNWM	RLGHNCSE
MIAMFLBR	MMPHTNZP	NWORLAAR	RLGHNCSC
MIAMFLCA	MNDRFLAV	NWORLAAV	RLGHNCSE
MIAMFLDB	MNDRFLLO	NWORLABM	RLGHNCSE
MIAMFLFL	MTGMAL11	NWORLACA	SMYRGAGP
MIAMFLGR	MTGMALBI	NWORLACM	SMYRGAMA
MIAMFLHL	MTGMALDA	NWORLAFR	SMYRGAPF
MIAMFLIC	MTGMALMB	NWORLAIY	TUKRGAMA
MIAMFLKE	MTGMALMT	NWORLALK	VRBHFLBE
MIAMFLME	MTGMALNO	NWORLAMA	VRBHFLMA
MIAMFLNM	MTRELABK	NWORLAMC	WCLMSCES
MIAMFLNS	MTRELARS	NWORLAMR	WCLMSCMA
MIAMFLOL	NDADFLAC	NWORLAMT	WPBHFLAA
MIAMFLPB	NDADFLBR	NWORLAMU	WPBHFLAN
MIAMFLPL	NDADFLGG	NWORLARV	WPBHFLGA
MIAMFLRC	NDADFLLO	NWORLASC	WPBHFLGR
MIAMFLRR	NDADFLAT	NWORLASK	WPBHFLHH
MIAMFLSH	NRCRGAMA	NWORLASW	WPBHFLLE
MIAMFLSO	NSVLTNAA	ORLDFLAP	WPBHFLRB
MIAMFLWD	NSVLTNAP	ORLDFLCL	WPBHFLRP
MIAMFLWM	NSVLTNBK	ORLDFLMA	
MMPHTNBA	NSVLTNBV	ORLDFLPC	
MMPHTNBM	NSVLTNBW	ORLDFLPH	

ISSUED: MARCH 2, 2023

EFFECTIVE: MARCH 17, 2023

ACCESS SERVICE

2 - General Regulations (Cont'd)

2.4 Payment Arrangements and Credit Allowances (Cont'd)

2.4.4 Credit Allowance for Service Interruptions (Cont'd)

(B) When a Credit Allowance Applies (Cont'd)

- (8) Application of credits for service outages for LightGate service (a.k.a. BellSouth SPA Point to Point Network), (excluding DS1 channel interfaces and DS3 Services subject to term plans renewed on or after March 17, 2023 or being provided on a month-to-month basis), will be calculated as follows: credits will be applied to the monthly rate associated with each activated interface affected, after ratcheting adjustments to account for BellSouth SWA service, if any, for the highest level channelized service. For system level rate elements, credits applied to the monthly rate associated with the system, after ratcheting adjustments for BellSouth SWA services, based upon the proportion which the interrupted Special Access, (a.k.a. BellSouth SPA) channels, in the system bear to the total activated Special Access (a.k.a. BellSouth SPA) channels, in the system. Where service interruptions of one minute or more per occasion occur, the credit applied shall be 1440/1440. Credit allowance limitations shall be in accordance with Section 2.4.4(B)(1). For DS1 channel interfaces and DS3 Services subject to term plans renewed on or after March 17, 2023 or being provided on a month-to-month basis, Sections 2.4.4(B)(7) and 2.4.4(B)(16) will apply. (T) (N) (N) (T) (N) (N)
- (9) Reserved for Future Use. (T)
- (10) Credit allowances for service interruptions on affected BellSouth SWA DS1 service Local Channel and/or Interoffice Channel elements will be based on the wire center group assignment of the customer's serving wire center, (see Group 1 Wire Center list contained in Section 2.4.4.(B)(10)). For BellSouth SWA DS1 facilities assigned to Group 1 wire centers, the customer shall be credited at the rate of 1440/1440 for service interruptions of one minute or more. BellSouth SWA DS1 customers with facilities assigned to Group 2 wire centers, (all other wire centers not included in Group 1) shall be credited for interruptions of more than 30 minutes but less than or equal to 210 minutes based on the credit allowance schedule following. (T)

ISSUED: MARCH 2, 2023

EFFECTIVE: MARCH 17, 2023

ACCESS SERVICE

2 - General Regulations (Cont'd)

2.4 Payment Arrangements and Credit Allowances (Cont'd)

2.4.4 Credit Allowance for Service Interruptions (Cont'd)

(B) When a Credit Allowance Applies (Cont'd)

(10) (Cont'd)

(T)

Service interruptions of 211 minutes or more the customer shall receive a credit of 1440/1440 of the monthly rate. Credit allowances for BellSouth SWA DS1 service interruptions involving more than one wire center group will be based on the respective local channel wire center group and the highest interoffice channel mileage wire center used in provisioning the service. Ratcheting, to account for Special Access (a.k.a. BellSouth SPA) services, will be applied to BellSouth SWA DS1 service interruption credits. Credit allowance limitations shall be in accordance with Section 2.4.4.(B)(1).

(T)

Credit Allowance Schedule
Group 2 Wire Centers

<u>Interruption Period</u>	<u>Credit Per Interruption</u>	
<u>30 Minutes to 150 Minutes – All</u>	360/1440	(T)
<u>151 Minutes to 210 Minutes – All</u>	720/1440	(T)
<u>211 Minutes or More – All</u>	1440/1440	(T)

ISSUED: MARCH 2, 2023

EFFECTIVE: MARCH 17, 2023

ACCESS SERVICE

2 - General Regulations (Cont'd)

2.4 Payment Arrangements and Credit Allowances (Cont'd)

2.4.4 Credit Allowance for Service Interruptions (Cont'd)

(B) When a Credit Allowance Applies (Cont'd)

- (11) Application of credits for service outages for BellSouth SWA DS3 will be calculated as follows: For the affected BellSouth Local Channel, Interoffice Channel and BellSouth SWA DS3 Channelization elements, credits will be applied to the monthly charge associated with each element affected for the highest level inoperative channelized service, after ratcheting adjustments to account for Special Access (a.k.a. BellSouth SPA) service, if any. Where service interruptions of one minute or more per occasion occur, the credit applied shall be 1440/1440 of the total monthly charge for the rate element involved. Credit allowance limitations shall be in accordance with Section 2.4.4.(B)(1) preceding. (T)
- (12) Application of credits for service outages of BellSouth DS1 Diverse service Local and Interoffice Channels will be calculated as follows: In the event of primary facility path failure, service is guaranteed to switch to an alternate facility path in one minute or less. Failure to meet this guarantee will result in credits being applied to the customer's bill equal to 1440/1440 of the monthly charge associated with the affected service element(s) (e.g., for the affected Local Channel, Interoffice Channel, DS1 Basic Channelization System and associated Central Office Channel Interface(s), and 1.544 Mbps elements of service associated with higher capacity Central Office Channel Interface channelization element(s), where the trouble is on the public right-of-way). Credits will be applied through normal administrative processes and the dollar amount will be reflected on the customer's bill. Ratcheting, to account for BellSouth SWA services, will be applied to BellSouth DS1 Diverse service interruption credits. A customer must report the outage in order to receive credit. The credits will apply no more than once per month and the total of all credits, including those in other sections of this Tariff, shall not exceed the monthly rate for service. (T)

ISSUED: MARCH 2, 2023

EFFECTIVE: MARCH 17, 2023

ACCESS SERVICE

2 - General Regulations (Cont'd)

2.4 Payment Arrangements and Credit Allowances (Cont'd)

2.4.4 Credit Allowance for Service Interruptions (Cont'd)

(B) When a Credit Allowance Applies (Cont'd)

(13) For Fast Packet Access Services,⁽¹⁾⁽²⁾ a service is considered interrupted when it becomes unusable to the customer because of a failure of a facility component used to furnish service under this tariff. An interruption period starts when the customer reports the interruption to the Telephone Company, and ends when the service is operative. Following are the credit allowances appropriate for Fast Packet Access Services; the credit allowance(s) for an interruption or for a series of interruptions shall not exceed the effective monthly rate for the Fast Packet Access Service. (T)

(a) In case of an interruption to any Fast Packet Access Service (except as specified otherwise in (b) following), the credit allowance for the period of the interruption, if not due to situations set forth in 2.4.4.(C), shall be as follows:

- For Exchange Access Frame Relay Service⁽¹⁾⁽²⁾ no credit shall be allowed for an interruption of less than 30 minutes. The customer shall be credited for an interruption of 30 minutes or more at the rate of 1/1440 of the monthly charges for the facility or service for each period of 30 minutes or major fraction thereof that the interruption continues.

For the service impacted by the service outage, the Fast Packet Access Service rate elements used to determine the credit allowance amount shall be as follows:

- All network interfaces

- (1) Effective November 5, 2011, Exchange Access Frame Relay Service (XAFRS) (a.k.a. BellSouth Exchange Access Frame Relay Service) as described in Section 21.2, following, and BellSouth Managed Shared Frame Relay Service (MSFRS) as described in 21.3, following, will no longer be available to new Customers. Existing term plan Customers, as of November 5, 2011, may add, move, remove or change lines and/or locations for the durations of their current term plan agreements, but may not enter into any new term plan agreements. Existing Customers will be permitted one extension of any existing, non-expired term plan agreement past its current term for twelve (12) months, provided the extension is signed on or before March 31, 2012. Upon expiration of any term plan agreement (including any permitted extension), service will continue on a month-to-month basis until the service is discontinued by the Telephone Company.
- (2) Exchange Access Frame Relay Service (a.k.a. BellSouth Exchange Access Frame Relay Service), BellSouth Exchange Access Asynchronous Transfer Mode Service, BellSouth Managed Shared Frame Relay Service, and BellSouth Managed Shared Asynchronous Transfer Mode Service have been discontinued and are no longer available in this publication (see WC Dkt. 11-120).

ISSUED: MARCH 2, 2023

EFFECTIVE: MARCH 17, 2023

ACCESS SERVICE

2 - General Regulations (Cont'd)

2.4 Payment Arrangements and Credit Allowances (Cont'd)

2.4.4 Credit Allowance for Service Interruptions (Cont'd)

(B) When a Credit Allowance Applies (Cont'd)

(13)(Cont'd)

(T)

- (b) In case of an interruption to Managed Shared Frame Relay Service,⁽¹⁾⁽²⁾ a Service Continuity Credit as follows (instead of the standard Fast Packet Access Service credit allowance for outages set forth previously in (a)) shall apply for service outages according to the schedule provided below if the outage is not due to situations set forth in 2.4.4(C). The customer will be credited the percentage of his effective monthly rate for the MSFRS Connections that are affected by the service interruption (i.e., effective monthly rate meaning the monthly rate discounted by the appropriate Fast Packet Savings Plan discount percentage, if applicable) based upon the period of the actual service outage as set forth in the following chart:

<u>Duration of Service Outage</u>	<u>Service Continuity Credit Percentage</u>
0 - 240 minutes	0%
241 - 360 minutes	33%
361 - 480 minutes	66%
Over 480 minutes	100%

For the services impacted by the service outage, the rate elements used to determine the Service Continuity Credit amount shall be as follows:

- For Managed Shared Frame Relay Service:⁽¹⁾⁽²⁾ MSFRS Connections

- (1) Effective November 5, 2011, BellSouth Managed Shared Frame Relay Service (MSFRS) as described in 21.3, following, will no longer be available to new Customers. Existing term plan Customers, as of November 5, 2011, may add, move, remove or change lines and/or locations for the durations of their current term plan agreements, but may not enter into any new term plan agreements. Existing Customers will be permitted one extension of any existing, non-expired term plan agreement past its current term for twelve (12) months, provided the extension is signed on or before March 31, 2012. Upon expiration of any term plan agreement (including any permitted extension), service will continue on a month-to-month basis until the service is discontinued by the Telephone Company.
- (2) Exchange Access Frame Relay Service (a.k.a. BellSouth Exchange Access Frame Relay Service), BellSouth Exchange Access Asynchronous Transfer Mode Service, BellSouth Managed Shared Frame Relay Service, and BellSouth Managed Shared Asynchronous Transfer Mode Service have been discontinued and are no longer available in this publication (see WC Dkt. 11-120).

(This page filed under Transmittal No. 174)

ISSUED: MARCH 2, 2023

EFFECTIVE: MARCH 17, 2023

2 - General Regulations (Cont'd)

2.4 Payment Arrangements and Credit Allowances (Cont'd)

2.4.4 Credit Allowance for Service Interruptions (Cont'd)

(B) When a Credit Allowance Applies (Cont'd)

(13) (Cont'd)

(T)

- (c) In case of an interruption to Fast Packet Access Services subscribed with the Special Provisioning Feature, a Special Provisioning Credit as follows (instead of the standard Fast Packet Access Service credit allowance for outages set forth previously in (a) and (b)) shall apply for service outages if the outage is not due to situations set forth in 2.4.4.(C).

Except for network maintenance windows, if both circuits in a Special Provisioning service relationship fail at the same time and it is determined that both failed at the same time because diversity was not maintained in the Telephone Company's network, then the Telephone Company will provide a credit equal to one full month's charge for each circuit on the subsequent invoice. The credit itself will be equal to what the customer would have actually paid that month (credit is net of any FSP credits).

For the services impacted by the service outage, the rate elements used to determine the Special Provisioning Credit amount shall be as follows:

- For Exchange Access Frame Relay Service:⁽¹⁾⁽²⁾ XAFRS Network Interfaces
- For Managed Shared Frame Relay Service:⁽¹⁾⁽²⁾ MSFRS Connections
- Special Provisioning Feature Charges

- (1) Effective November 5, 2011, Exchange Access Frame Relay Service (XAFRS) (a.k.a. BellSouth Exchange Access Frame Relay Service) as described in Section 21.2, following, and BellSouth Managed Shared Frame Relay Service (MSFRS) as described in 21.3, following, will no longer be available to new Customers. Existing term plan Customers, as of November 5, 2011, may add, move, remove or change lines and/or locations for the durations of their current term plan agreements, but may not enter into any new term plan agreements. Existing Customers will be permitted one extension of any existing, non-expired term plan agreement past its current term for twelve (12) months, provided the extension is signed on or before March 31, 2012. Upon expiration of any term plan agreement (including any permitted extension), service will continue on a month-to-month basis until the service is discontinued by the Telephone Company.
- (2) Exchange Access Frame Relay Service (a.k.a. BellSouth Exchange Access Frame Relay Service), BellSouth Exchange Access Asynchronous Transfer Mode Service, BellSouth Managed Shared Frame Relay Service, and BellSouth Managed Shared Asynchronous Transfer Mode Service have been discontinued and are no longer available in this publication (see WC Dkt. 11-120).

ISSUED: MARCH 2, 2023

EFFECTIVE: MARCH 17, 2023

ACCESS SERVICE

2 - General Regulations (Cont'd)

2.4 Payment Arrangements and Credit Allowances (Cont'd)

2.4.4 Credit Allowance for Service Interruptions (Cont'd)

(B) When a Credit Allowance Applies (Cont'd)

(14) ⁽¹⁾

(D)(T)

(D)

(T)

(15) For BellSouth Wavelength SWA Channel Service Components and BellSouth Channel Service, a credit for a service interruption involving the failure of a Dedicated System and/or Wavelength Channel service components shall apply. For a failure of thirty minutes or greater, the credit shall equal 100 percent of the current billed rate associated with the affected service components. All credit allowances shall begin from the time of notice by the customer to the Company and will end when the service is operative. A customer must report the outage in order to receive service outage credit. The total credit received in any month for each service component shall not exceed the monthly rate for the service component.

(1) Material in this Section has been de-tariffed as required by the Commission upon use of the forbearance relief pursuant to FCC Memorandum Opinion and Order No. FCC 07-180, released October 12, 2007. Terms and Conditions associated with de-tariffed services are available at www.att.com/guidebook.

(N)

(N)

ISSUED: MARCH 2, 2023

EFFECTIVE: MARCH 17, 2023

ACCESS SERVICE

2 - General Regulations (Cont'd)

2.4 Payment Arrangements and Credit Allowances (Cont'd)

2.4.4 Credit Allowance for Service Interruptions (Cont'd)

(B) When a Credit Allowance Applies (Cont'd)

(16) Service Assurance Warranty (SAW)

(T)

Credit allowances for service interruptions on DS1 Special Access service will be calculated as provided below. Section 2.4.4(B)(16) applies to DS1 Special Access circuits when Section 2.4.4(B)(7) no longer applies.

(T)

(T)(D)

Credit allowances for service interruptions on LightGate DS3 Service subject to term plans renewed on or after March 17, 2023 or being provided on a month-to-month basis, will be calculated as provided below. Section 2.4.4(B)(16) applies to LightGate DS3 circuits when Section 2.4.4(B)(8) no longer applies.

(N)

|

(N)

No credit shall be allowed for an interruption period of less than 30 minutes. For each period of 30 minutes, or fraction thereof, that the interruption continues after the initial 30-minute outage, the Customer will be credited at the rate of 1/1440 of the monthly charges until the outage reaches 4 hours. When the total service interruption on the same service exceeds 4 hours, the Customer shall receive a SAW credit as follows:

(i) For the initial 4-hour outage on DS1 Special Access Service, in a 30-day period, the Customer will be credited \$120.

(N)

(ii) For the initial 4-hour outage on LightGate DS3 Service applicable to this section, in a 30-day period, the Customer will be credited \$380.

(N)

(N)

(iii) Additional service interruptions that are 4 hours or greater that occur in the same 30-day period will be calculated at the rate of 1/1440 per 30-minute interval.

(T)

The total credit allowance available to the Customer, regardless of the number or type of service interruptions within a 30-day period, will not exceed 100% of the combined monthly rates per affected service.

ISSUED: JUNE 30, 2020

EFFECTIVE: JULY 15, 2020

ACCESS SERVICE

2 - General Regulations (Cont'd)

2.4 Payment Arrangements and Credit Allowances (Cont'd)

2.4.4 Credit Allowance for Service Interruptions (Cont'd)

(C) When a Credit Allowance Does Not Apply

No credit allowance will be made for:

- (1) Interruptions caused by the negligence of the customer, the customer's end user or the customer/end user's authorized agent.
- (2) Interruptions of a service due to the failure of equipment or systems provided by the customer or others.
- (3) Interruptions of a service during any period in which the Telephone Company is not afforded access to the premises where the service is terminated.
- (4) Interruptions of a service when the customer has released that service to the Telephone Company for maintenance purposes, to make rearrangements, or for the implementation of an order for a change in the service during the time that was negotiated with the customer prior to the release of that service. Thereafter, a credit allowance as set forth in (B) preceding applies.
- (5) Interruptions of a service which continue because of the failure of the customer to authorize replacement of any element of special construction, as set forth in BELLSOUTH TELECOMMUNICATIONS TARIFF F.C.C. NO. 2 for Special Construction. The period for which no credit allowance is made begins on the seventh day after the customer receives the Telephone Company's written notification of the need for such replacement and ends on the day after receipt by the Telephone Company of the customer's written authorization for such replacement.
- (6) Periods when the customer elects not to release the service for testing and/or repair and continues to use it on an impaired basis.
- (7) Periods of temporary discontinuance as set forth in 2.2.1(B) preceding.

ISSUED: MARCH 2, 2023

EFFECTIVE: MARCH 17, 2023

ACCESS SERVICE

2 - General Regulations (Cont'd)

2.4 Payment Arrangements and Credit Allowances (Cont'd)

2.4.4 Credit Allowance for Service Interruptions (Cont'd)

(C) When a Credit Allowance Does Not Apply (Cont'd)

- (8) An interruption or a group of interruptions, resulting from a common cause, for amounts less than one dollar.
- (9) Periods of interruption as set forth in 13.3.1 following.
- (10) Interruptions of a service due to commercial power failure.
- (11) Interruptions of a service due to labor difficulties, governmental orders, civil commotions, criminal action against the Telephone Company, acts of God, war, or other circumstances beyond the Telephone Company's control.
- (12) When unbundled network elements (UNEs) or combinations of UNEs are commingled with Access Services purchased under this Tariff.
- (13) When the Telephone Company has identified a condition that requires maintenance, and the customer refuses to release the service to the Telephone Company for repair and a subsequent service interruption occurs.
- (14) Periods of interruption due to testing and/or repair during any maintenance window agreed to in advance by the customer and the Telephone Company in response to a customer reported trouble.
- (15) Trouble tickets that Telephone Company closed with the coding of came clear (CC), no trouble found (NTF), or test okay (TOK). (N)
(N)

ISSUED: JUNE 30, 2020

EFFECTIVE: JULY 15, 2020

ACCESS SERVICE

2 - General Regulations (Cont'd)

2.4 Payment Arrangements and Credit Allowances (Cont'd)

2.4.4 Credit Allowance for Service Interruptions (Cont'd)

(D) Use of an Alternative Service Provided by the Telephone Company

Should the customer elect to use an alternative service provided by the Telephone Company during the period that a service is interrupted, the customer must pay the tariffed rates and charges for the alternative service used.

(E) Temporary Surrender of a Service

In certain instances, the customer may be requested by the Telephone Company to surrender a service for purposes other than maintenance, testing or activity relating to a service order. If the customer consents, a credit allowance will be granted. The credit allowance will be 1/1440 of the monthly rate for each period of 30 minutes or fraction thereof that the service is surrendered. In no case will the credit allowance exceed the monthly rate for the service surrendered in any one monthly billing period.

2.4.5 Reestablishment of Service Following Fire, Flood or Other Occurrence

(A) Nonrecurring Charges Do Not Apply

Charges do not apply for the reestablishment of service following a fire, flood or other occurrence attributed to an act of God provided that:

- (1) The service is of the same type as was provided prior to the fire, flood or other occurrence.

ISSUED: JUNE 16, 2011

EFFECTIVE: JULY 1, 2011

ACCESS SERVICE

2 - General Regulations (Cont'd)

2.4 Payment Arrangements and Credit Allowances (Cont'd)

2.4.5 Reestablishment of Service Following Fire, Flood or Other Occurrence
(Cont'd)

(A) Nonrecurring Charges Do Not Apply (Cont'd)

- (2) The service is for the same customer.
- (3) The service is at the same location on the same premises.
- (4) The reestablishment of service begins within 60 days after Telephone Company service is available. (The 60 day period may be extended a reasonable period if the renovation of the original location on the premises affected is not practical within the allotted time period.)

(B) Nonrecurring Charges Apply

Nonrecurring Charges apply for establishing service at a different location on the same premises or at a different premises pending reestablishment of service at the original location.

2.4.6 Title or Ownership Rights

The payment of rates and charges by customers for the services offered under the provisions of this tariff does not assign, confer or transfer title or ownership rights to proposals or facilities developed or utilized, respectively, by the Telephone Company in the provision of such services.

2.4.7 Billing of Access Service Provided by Multiple Companies

The Telephone Company will adhere to the standards for billing of access service by multiple companies that are set forth in reference documents Ordering and Billing Forum: Multiple Exchange Carrier Access Billing (MECAB) and Ordering and Billing Forum: Multiple Exchange Carrier Ordering and Design (MECOD).

ISSUED: JUNE 16, 2011

EFFECTIVE: JULY 1, 2011

ACCESS SERVICE

2 - General Regulations (Cont'd)

2.4 Payment Arrangements and Credit Allowances (Cont'd)

2.4.7 Billing of Access Service Provided by Multiple Companies (Cont'd)

(A) Feature Group A (FGA) Service¹

When a Feature Group A (or LSBSA)² Switched Access Service is ordered by a customer where one end of the Transport Element is in the Telephone Company operating territory and the other end is in another Exchange Telephone Company operating territory, the Exchange Telephone Company in whose territory the FGA dial-tone office is located will accept the order. In addition, the Exchange Telephone Company in whose territory the customer's serving wire center is located must also receive a copy of the order from the customer. The Exchange Telephone Company that accepts the order will then determine the charges involved, arrange to provide the Access Service ordered and bill the charges in accordance with its Access Service Tariff.

Upon agreement of the Telephone Companies involved in the provision of FGA service, the dedicated portions of FGA service (i.e. Switched Dedicated Interoffice Channel, Switched Local Channel and Channelization Equipment) will be billed in accordance with the provision of (B) and (C) following. For non-dedicated portions of FGA service, including the Interconnection charge, the rates of the billing company will apply.

Note 1: Except where indicated herein, references to Feature Groups will also include the applicable Basic Serving Arrangement (BSA) as detailed in the matrix of Section 6.1.3(A)(5)(j) (e.g., the term FGA represents both FGA and Line Side Basic Serving Arrangement (LSBSA)).

Note 2: Where LSBSA is provisioned with a DNAL, this section, 2.4.7.(A), shall also apply to the DNAL.

ISSUED: SEPTEMBER 24, 2013

EFFECTIVE: OCTOBER 9, 2013

ACCESS SERVICE

2 - General Regulations (Cont'd)

2.4 Payment Arrangements and Credit Allowances (Cont'd)

2.4.7 Billing of Access Service Provided by Multiple Companies (Cont'd)

(B) Single Bill Arrangements

(1) General

If agreed to by the Exchange Telephone Companies involved in the provision of the service, single bill arrangements will be provided for Special Access and for FGB, FGD, and the dedicated portions of FGA Switched Access service. (D)

In the event that the Exchange Telephone Companies involved agree to change from one billing arrangement to another, the customer will be notified at least 30 days prior to the effective date of such change.

(2) Ordering

The customer shall place its access service request with each Exchange Telephone Company involved in the provision of the service.

(3) Rating and Billing of Service

The billing company will be as agreed to by the Exchange Telephone Companies involved in the provision of the service. The single bill arrangement may be provided under the following single bill alternatives if agreed to by such companies:

- (a) The billing company will bill and collect all appropriate charges in accordance with the regulations, rates and charges in its Access Service tariff, or

Note 1: Except where indicated herein, references to Feature Groups will also include the applicable Basic Serving Arrangement (BSA) as detailed in the matrix of Section 6.1.3(A)(5)(j) (e.g., the term FGA represents both FGA and Line Side Basic Serving Arrangement (LSBSA)).

ISSUED: JUNE 16, 2011

EFFECTIVE: JULY 1, 2011

ACCESS SERVICE

2 - General Regulations (Cont'd)

2.4 Payment Arrangements and Credit Allowances (Cont'd)

2.4.7 Billing of Access Service Provided by Multiple Companies (Cont'd)

(B) Single Bill Arrangements (Cont'd)

(3) Rating and Billing of Service (Cont'd)

- (b) The billing company will bill and collect all appropriate charges in accordance with the rates and charges in its access tariff, for the portion of the service it provides, and in accordance with the rates and charges of the access tariffs of the other Exchange Telephone Companies involved, for the portion of the service which they provide, with the exception that the billing company's billing regulations, (regulations regarding deposits, late payments, late payment penalties, disputes, interest credits, and extended billing), shall apply. The Interconnection charge of the end office Telephone Company will apply. The bill will separately identify each company's rates and charges, or
- (c) The billing company will bill and collect all appropriate charges in accordance with the rates and charges in the access tariffs of the other involved Exchange Telephone Companies, as forwarded to it by such companies for the portion of the service they provide, and in accordance with the rates and charges in its own access tariff for the portion of the service it provides. The Interconnection charge of the end office Telephone Company will apply. The bill will separately identify each company's rates and charges.

For 2.4.7(B)(3)(b) and (c) above, the charges billed for the portion of service provided by this Telephone Company are determined as set forth in 2.4.7(C)(3)(a), (b) and (c). For 2.4.7(B)(3)(a) above, for nonrecurring charges, 100% of this Telephone Company's charge shall apply.

ISSUED: SEPTEMBER 24, 2013

EFFECTIVE: OCTOBER 9, 2013

ACCESS SERVICE

2 - General Regulations (Cont'd)

2.4 Payment Arrangements and Credit Allowances (Cont'd)

2.4.7 Billing of Access Service Provided by Multiple Companies (Cont'd)

(C) Multiple Bill Arrangements

(1) General

Separate bills will be rendered by the Exchange Telephone Companies for Special Access and for FGB1, FGD, and the dedicated portions of FGA Switched Access Service if the administration of a single bill arrangement, as set forth in 2.4.7(B), is not agreed upon by the companies involved. In the event that the Exchange Telephone Companies involved agree to change from one billing arrangement to another, the customer will be notified at least 30 days prior to the effective date of such change. (D)

(2) Ordering

The customer shall place its access service request with each Exchange Telephone Company involved in the provision of the service.

(3) Rating and Billing of Service

Each company will provide its portion of the Access Service based on the regulations, rates and charges contained in its Access Service tariff, subject to the following rules, as appropriate:

(a) The charges billed by this company for mileage sensitive rate elements, e.g., Switched Access Service Switched Transport, Special Access Service Interoffice Channel, or Directory Assistance Transport, are determined as follows:

(i) The total mileage for the service is computed using V&H Coordinate Method set forth in NATIONAL EXCHANGE CARRIER ASSOCIATION, INC., TARIFF F.C.C. NO. 4.

Note 1: Except where indicated herein, references to Feature Groups will also include the applicable Basic Serving Arrangement (BSA) as detailed in the matrix of Section 6.1.3(A)(5)(j) (e.g., the term FGA represents both FGA and Line Side Basic Serving Arrangement (LSBSA)).

ISSUED: JUNE 16, 2011

EFFECTIVE: JULY 1, 2011

ACCESS SERVICE

2 - General Regulations (Cont'd)

2.4 Payment Arrangements and Credit Allowances (Cont'd)

2.4.7 Billing of Access Service Provided by Multiple Companies (Cont'd)

(C) Multiple Bill Arrangements (Cont'd)

(3) Rating and Billing of Service (Cont'd)

(a) (Cont'd)

(ii) A billing factor is determined from NATIONAL EXCHANGE CARRIER ASSOCIATION INC. (NECA) TARIFF F.C.C. NO. 4 directly.

(iii) This company's rates and charges are then multiplied by the appropriate quantity(ies) and the billing factor to obtain the charges for this company.

An example of this methodology is shown in 2.4.7(C)(4) following.

(b) The application of nondistance sensitive rate elements varies according to the rate structure and the location of the facilities involved:

(i) When rates and charges are listed on a per point of termination basis, this company's rates will be billed for the termination(s) within this company's operating territory.

(ii) When rates and charges are listed on a per unit basis, e.g., central office bridging or channelization, this company's rates and charges will apply for units located in this company's operating territory. For switched access common transport between a Telephone Company access tandem and an end office of another telephone company, 50% of this telephone company's Common Transport DS3 to DS1 Multiplexer rate, as set forth in Section 6.8.1(B)(2)(a), and this telephone company's Directory Transport DS3 to DS1 Multiplexer rate, as set forth in Section 9.1.6(B)(6) shall apply.

(iii) When rates and charges are developed on an individual case basis, such rates will be developed for the portion of the service provided by this company.

ISSUED: JUNE 16, 2011

EFFECTIVE: JULY 1, 2011

ACCESS SERVICE

2 - General Regulations (Cont'd)

2.4 Payment Arrangements and Credit Allowances (Cont'd)

2.4.7 Billing of Access Service Provided by Multiple Companies (Cont'd)

(C) Multiple Bill Arrangements (Cont'd)

(3) Rating and Billing of Service (Cont'd)

(b) (Cont'd)

- (iv) When rates and charges are listed on a per service basis, this company's rates and charges are allocated based upon the ratio of points on the access circuit that this company owns, in relation to the total number of points on the circuit.
- (v) For Special Access Interoffice Channel fixed rates, 50% of this company's rate will apply for each end of the Interoffice Channel that this company provides.

For example:

If the Interoffice Channel fixed rate is \$11.80, and this company provides only one end of the Interoffice Channel, the rate would be 50% of \$11.80, or \$5.90.

If this company does not provide either end of the Interoffice Channel, this company's Interoffice Channel fixed rate shall not apply.

- (vi) For Switched Interoffice Channel Facility Termination rates, 50% of this company's rate will apply for each end of the Switched Interoffice Channel that this company provides.

ISSUED: JUNE 16, 2011

EFFECTIVE: JULY 1, 2011

ACCESS SERVICE

2 - General Regulations (Cont'd)

2.4 Payment Arrangements and Credit Allowances (Cont'd)

2.4.7 Billing of Access Service Provided by Multiple Companies (Cont'd)

(C) Multiple Bill Arrangements (Cont'd)

(3) Rating and Billing of Service (Cont'd)

(b) (Cont'd)

(vi) (Cont'd)

For example:

If the Switched Dedicated Interoffice Channel Facility Termination rate is \$15.00, and this company provides only one end of this Switched Dedicated Interoffice Channel, the rate would be 50% of \$15.00, or \$7.50.

If this Company does not provide either end of the Switched Interoffice Channel, this company's Switched Interoffice Channel Facility Termination rate shall not apply.

(vii) Where this company is the end office company, 100% of this Company's Interconnection charge will apply.

(c) For nonrecurring charges, 100% of this company's charge shall apply; provided, however, that for installation charges pursuant to Section 6.8.1(E), only 50% of this Company's installation charges will apply where, for trunk installations this Telephone Company owns neither the involved end office or access tandem, or for line side installations this Company does not own the Feature Group A dial tone office.

ISSUED: JUNE 16, 2011

EFFECTIVE: JULY 1, 2011

ACCESS SERVICE

2 - General Regulations (Cont'd)

2.4 Payment Arrangements and Credit Allowances (Cont'd)

2.4.7 Billing of Access Service Provided by Multiple Companies (Cont'd)

(C) Multiple Bill Arrangements (Cont'd)

(4) Multiple Bill Example¹ for Switched Transport Rate Elements

Assume Switched Dedicated or Common Transport is ordered to an End Office in the operating territory of Company A. The Customer Premises is located in the operating territory of Company B.

(a) Switched Dedicated Transport

Assume 20 miles of Switched Dedicated Transport (DT); Assume 8,000 minutes of use; Assume billing factor from NECA 4 of 28% for Company A and 72% for Company B.

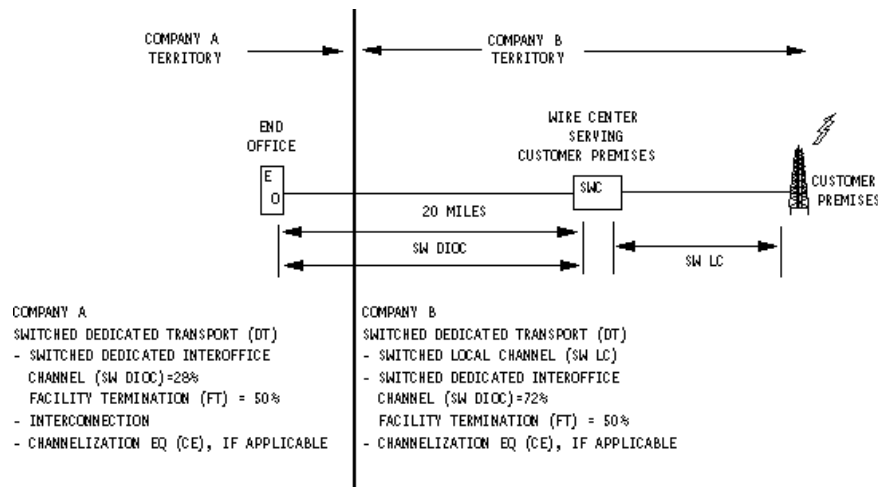

Note 1: Rates used in each example are for example purposes only.

ISSUED: JUNE 16, 2011

EFFECTIVE: JULY 1, 2011

ACCESS SERVICE

2 - General Regulations (Cont'd)

2.4 Payment Arrangements and Credit Allowances (Cont'd)

2.4.7 Billing of Access Service Provided by Multiple Companies (Cont'd)

(C) Multiple Bill Arrangements (Cont'd)

(4) Multiple Bill Example¹ for Switched Transport Rate Elements (Cont'd)

(a) (Cont'd)

Switched Dedicated Transport

COMPANY A - DT = \$1.00 per mile, FT = \$25.00 per month
INTERC. = \$.002 per mou

(DT) 20 mi * \$1.00 * 28% = \$ 5.60
(FT) \$25.00 * 50% = \$12.50
(INTERC.) \$.002 * 8,000 mou = \$16.00

COMPANY A SWITCHED TRANSPORT = \$34.10

COMPANY B - DT = \$.50 per mile
FT = \$15.00 per month
SW LC = \$10.00 per month

(SW LC) = \$10.00
(FT) \$15.00 * 50% = \$ 7.50
(DT) 20 mi * \$.50 * 72% = \$ 7.20

COMPANY B SWITCHED TRANSPORT \$24.70

Note 1: Rates used in each example are for example purposes only.

ISSUED: JUNE 16, 2011

EFFECTIVE: JULY 1, 2011

ACCESS SERVICE

2 - General Regulations (Cont'd)

2.4 Payment Arrangements and Credit Allowances (Cont'd)

2.4.7 Billing of Access Service Provided by Multiple Companies (Cont'd)

(C) Multiple Bill Arrangements (Cont'd)

(4) Multiple Bill Example¹ For Switched Transport Rate Elements (Cont'd)

(b) Switched Common Transport

Assume 20 miles of Switched Common Transport (CT); 20 miles of Switched Dedicated Transport (DT); and 8,000 minutes of use; with a billing factor from NECA 4 of 28% for Company A and 72% for Company B.

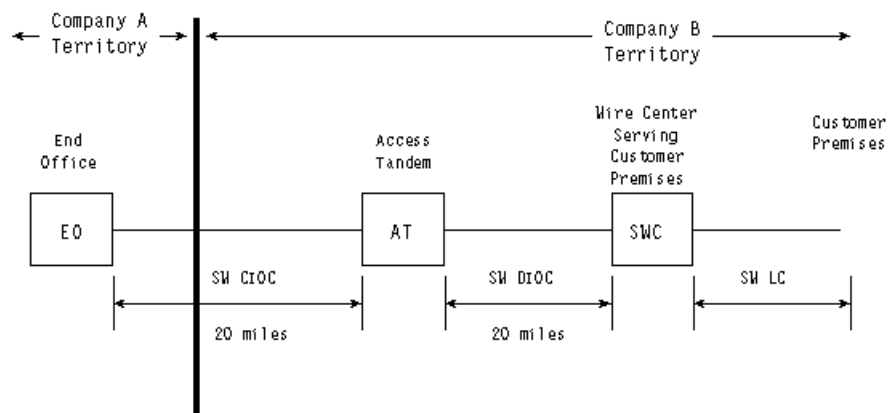

Company A
 Switched Common Transport (CT)
 -Switched Common Interoffice Channel (SW CIOC) = 28%
 -Facility Termination (FT) = 50%
 Interconnection

Company B
 Switched Local Channel (SW LC)
 Switched Common Transport (CT)
 -Sw'd Common Interoffice Ch (SW CIOC) = 72%
 -Facility Termination = 50%
 Switched Dedicated Interoffice Ch (SW DIOC)
 -Sw'd Ded'd Interoffice Ch (SW DIOC) = 100%
 -Facility Termination = 100%
 Access Tandem Switching (AT SW)
 Channelization EQ (CE), if applicable

Note 1: Rates used in examples are for example purposes only and do not include multiplexing, tandem trunk ports and end office trunk ports.

ISSUED: JUNE 16, 2011

EFFECTIVE: JULY 1, 2011

ACCESS SERVICE
2 - General Regulations (Cont'd)

2.4 Payment Arrangements and Credit Allowances (Cont'd)

2.4.7 Billing of Access Service Provided by Multiple Companies (Cont'd)

(C) Multiple Bill Arrangements (Cont'd)

(4) Multiple Bill Example¹ for Switched Transport Rate Elements (Cont'd)

(b) Switched Common Transport (Cont'd)

COMPANY A - CT = \$.0001 per mou/per mile
CT FT = \$.0001 per mou
INTERC. = \$.002 per mou

(INTERC.) \$.002 * 8,000 mou = \$16.00
(CT) 20 mi * \$.0001 * 8,000 mou * 28% = \$ 4.48
(CT FT) \$.0001 * 8,000 mou * 50% = \$.40

COMPANY A SWITCHED TRANSPORT = \$20.88

COMPANY B - CT = \$.0003 per mou/per mile
CT FT = \$.0001 per mou
DT = \$ 2.00 per mile
DT FT = \$30.00 per month
AT Switching = \$.00005 per mou
SW LC = \$10.00

(SW LC) = \$10.00
(AT SW) \$.00005 * 8,000 mou = \$.40
(CT) 20 mi * \$.0001 * 8,000 mou * 72% = \$11.52
(CT FT) \$.0001 * 8,000 mou * 50% = \$.40
(DT) 20 mi * \$2.00 = \$40.00
(DT FT) \$30.00 = \$30.00

COMPANY B SWITCHED TRANSPORT = \$92.32

Note 1: Rates used in examples are for example purpose only and do not include multiplexing, tandem trunk ports and end office trunk ports.

ISSUED: JANUARY 2, 2024

EFFECTIVE: JANUARY 17, 2024

ACCESS SERVICE

2 - General Regulations (Cont'd)

2.4 Payment Arrangements and Credit Allowances (Cont'd)

2.4.8 Optional Payment Plans

(A) Channel Services Payment Plan

(1) General

- (a) The regulations specified herein are applicable only to specific special access services as indicated in the rate regulations for such services in Section 7 of this tariff.
- (b) The terms of this Channel Services Payment Plan (CSPP) apply to such specific special access services except as noted in the rate regulations for the given service.
- (c) The CSPP allows customers to pay stabilized monthly rates for fixed service periods selected by the customer. The six payment plans offered are Plans D, A, B, C and Plans 1 and 2. The applicable payment plans for a particular service are set forth in the Rate Regulations section applicable to that service.

The service period for each plan is shown below.

- Payment Plan D, 12 Month Term Plan.⁽⁴⁾⁽⁶⁾
- Payment Plan A, service periods may be selected from 24 months to 48 months in length.⁽²⁾⁽³⁾⁽⁵⁾
- Payment Plan B, service periods may be selected from 49 months to 72 months in length.⁽²⁾⁽³⁾
- Payment Plan C, service periods may be selected from 73 months to 96 months in length.⁽¹⁾⁽²⁾⁽³⁾
- Payment Plan 1, service periods may be selected from 12 months to 36 months in length.⁽³⁾
- Payment Plan 2, service periods may be selected from 37 months to 60 months in length.⁽³⁾

(N)

As of August 23, 1996, new LightGate (a.k.a. BellSouth SPA Point to Point Network) system installations must be ordered under Transport Payment Plan (TPP)⁽³⁾ arrangements as specified in 2.4.8(D) following.

⁽¹⁾ Effective May 15, 2015, Plan C commitment periods of 74 to 96 months will no longer be available for new CSPPs. A Plan C commitment period of 73 months will continue to be available for new CSPPs. There is no change for existing CSPPs.

⁽²⁾ Effective on September 13, 2017, CSPPs greater than 36-months are no longer available for High Capacity (a.k.a. BellSouth SPA High Capacity DS1 (a.k.a. BellSouth SPA DS1)) service and SMARTPath Service (a.k.a. BellSouth SPA DS1 Shared Ring), and CSPPs are no longer available for Metallic (a.k.a. BellSouth SPA Metallic), Telegraph Grade (a.k.a. BellSouth SPA Telegraph), Voice Grade (a.k.a. BellSouth SPA VG), WATS Access Line (WAL) (a.k.a. BellSouth SPA WATS Lines), Derived Data Channel (a.k.a. BellSouth SPA Derived Data Channel), Digital Data Access Service (a.k.a. BellSouth SPA DS0 Digital Data) and BellSouth SPA Customer Network Management (CNM) - FlexServ Service, including for any otherwise available renewals or conversions. Circuits already subject to a CSPP, as of September 13, 2017, will continue to be provided under the then-current CSPP term for the remainder of that term.

⁽³⁾ Effective on November 1, 2022, all ACPs for High Capacity (a.k.a. BellSouth SPA High Capacity DS1 (a.k.a. BellSouth SPA DS1)), CSPPs of greater than 24 months for High Capacity (a.k.a. BellSouth SPA High Capacity DS1 (a.k.a. BellSouth SPA DS1)), SMARTPath Service (a.k.a. BellSouth SPA DS1 Shared Ring), and SMARTPath DS3 Transport Service (a.k.a. BellSouth SPA DS3 Shared Ring), and TPPs greater than 12 months for BellSouth DS1 Diverse Service and LightGate Systems (a.k.a. BellSouth SPA Point to Point Network), are no longer available, including for any otherwise available conversions. Circuits already subject to ACPs, CSPPs, and TPPs, as of November 1, 2022, will continue to be provided under the then-current term for the remainder of that term.

⁽⁴⁾ For services applicable to the Term Plan, see Section 7.5 on Page 7-203.

⁽⁵⁾ Effective December 1, 2023, CSPPs of 24 months for High Capacity (a.k.a. BellSouth SPA High Capacity DS1 (a.k.a. BellSouth SPA DS1)) are no longer available, including for any otherwise available conversions. Circuits already subject to CSPPs, as of December 1, 2023, will continue to be provided under the then-current term for the remainder of that term.

⁽⁶⁾ Effective on January 17, 2024, all CSPP and TPPs term plans greater than month-to-month for High Capacity (a.k.a. BellSouth SPA High Capacity DS1 (a.k.a. BellSouth SPA DS1)), SMARTPath Service (a.k.a. BellSouth SPA DS1 Shared Ring), SMARTPath DS3 Transport Service (a.k.a. BellSouth SPA DS3 Shared Ring), BellSouth DS1 Diverse Service and LightGate Systems (a.k.a. BellSouth SPA Point to Point Network), are no longer available, including for any otherwise available conversions. Existing Term Plan Services on January 17, 2024, will continue to be provided for the remainder of the then-current terms.

(N)
|
(N)

ISSUED: JUNE 30, 2020

EFFECTIVE: JULY 15, 2020

ACCESS SERVICE

2 - General Regulations (Cont'd)

2.4 Payment Arrangements and Credit Allowances (Cont'd)

2.4.8 Optional Payment Plans (Cont'd)

(A) Channel Services Payment Plan (Cont'd)

(1) General (Cont'd)

- (d) When the customer renews a CSPP arrangement under 2.4.8(A)(7)(d) following and the sum of months is greater than the number of months for which the service is available under a CSPP, the current rates for the longest payment plan available for that service will apply. At the expiration of existing CSPP arrangements for LightGate (a.k.a. BellSouth SPA Point to Point Network) ⁽¹⁾ customers must renew the service under a TPP arrangement as described under 2.4.8(D) following. Renewals of CSPP arrangements are not permitted.
- (e) When the customer orders service to be provided under a CSPP arrangement, the customer must designate to the Telephone Company the payment plan and the service period desired, e.g. Plan C and 84 Months.
- (f) Rates stabilized under a CSPP arrangement are exempt from Telephone Company initiated increases, however, decreases for any rate element will automatically be reflected in the rates charged to the customer.
- (g) At the expiration of existing Channel Services Payment Plan (CSPP) arrangements for LightGate (a.k.a. BellSouth SPA Point to Point Network) customers must renew the service under a TPP arrangement as described under (7)(d) following. If the customer does not elect to either discontinue service or renew under a new TPP arrangement, service will be continued under month-to-month rates.
- (h) Renewals for existing CSPP arrangements will not be available for LightGate (a.k.a. BellSouth SPA Point to Point Network) ⁽¹⁾ system installation on or after August 23, 1996. New LightGate (a.k.a. BellSouth SPA Point to Point Network) system installations on or after August 23, 1996, must be ordered under TPP arrangements.

ISSUED: JUNE 16, 2011

EFFECTIVE: JULY 1, 2011

ACCESS SERVICE

2 - General Regulations (Cont'd)

2.4 Payment Arrangements and Credit Allowances (Cont'd)

2.4.8 Optional Payment Plans (Cont'd)

(A) Channel Services Payment Plan (Cont'd)

(1) General (Cont'd)

(i) Starting February 16, 2002 and ending May 15, 2002, services under an existing CSPP arrangement may be converted to an Area Commitment Plan (ACP) arrangement without termination liability. This applies for conversion to comparable ACP commitment rate elements where the time remaining in the commitment period for the ACP arrangement is equal to or greater than the time remaining in the existing CSPP arrangement that is being converted. With this conversion, the ACP commitment level for a new ACP must be equal to the amount of services under CSPP that are being converted, or the ACP commitment level for an existing ACP must be increased by an amount equal to the amount of services under CSPP that are being converted.

(2) Application of Rates

(a) The stabilized monthly recurring rates applicable are those set forth in 7.5 following for the particular service involved as of the Application Date, provided that the actual service date does not exceed the later of the following:

ISSUED: JUNE 30, 2020

EFFECTIVE: JULY 15, 2020

ACCESS SERVICE

2 - General Regulations (Cont'd)

2.4 Payment Arrangements and Credit Allowances (Cont'd)

2.4.8 Optional Payment Plans (Cont'd)

(A) Channel Services Payment Plan (Cont'd)

(2) Application of Rates (Cont'd)

(1) the Service Date under a standard service interval, or

(2) the earliest date on which service can reasonably be made available to the customer by the Telephone Company.

(b) If the customer desires a service date later than as provided in (a) preceding, the stabilized monthly recurring rates in effect at the time of the actual service date are applicable.

(3) Additions

(a) Additions of services or rate elements, for activating spare or unused capacities of a service under a CSPP arrangement, must be activated at the same stabilized monthly recurring rates specified under the existing CSPP arrangement except for 2.4.8(A), 3(b) and 3(c) following.

(b) LightGate (a.k.a. BellSouth SPA Point to Point Network) CSPP customers must activate spare or unused channel interfaces under the same stabilized monthly recurring rates specified under the existing CSPP arrangement.

(c) Increases in capacity of LightGate (a.k.a. BellSouth SPA Point to Point Network) systems channels and/or nodes are permitted under CSPP. Such changes may be made by converting the CSPP arrangement to a TPP arrangement as specified in 2.4.8(D) following. When a LightGate system (a.k.a. BellSouth SPA Point to Point Network) channel and/or node is added to an existing CSPP arrangement, the payment plan will convert to a TPP arrangement as specified in 2.4.8(D).

(4) Disconnects

(a) When a service or rate element, included under a CSPP arrangement, is disconnected prior to expiration of the selected service period, termination liability charges apply as set forth in the rate regulations in this tariff for such service. Remaining services or rate elements will not be affected by such disconnections.

(b) When a tariffed service under a CSPP arrangement is disconnected prior to the expiration of a selected service period as a result of a customer requested change to a higher order of a separately tariffed service at the same location, termination liability charges will not apply when:

ISSUED: JUNE 30, 2020

EFFECTIVE: JULY 15, 2020

ACCESS SERVICE

2 - General Regulations (Cont'd)

2.4 Payment Arrangements and Credit Allowances (Cont'd)

2.4.8 Optional Payment Plans (Cont'd)

(A) Channel Services Payment Plan (Cont'd)

(4) Disconnects (Cont'd)

(b) (Cont'd)

- (1) the completed service period is 12 months, or 25% of the length of the originally selected CSPP service period, whichever is greater, and
- (2) the service period of the new CSPP arrangement for the higher order of service is equal to or longer than the remaining service period of the disconnected arrangement, and
- (3) the service orders to install the new higher order of service and disconnect the old service are related together and received by the Telephone Company at the same time, and there is no lapse in service between installation of the higher order of service and disconnection of the existing service, and
- (4) the capacity of the higher service is equal to or greater than the existing service. For converting LightGate service (a.k.a. BellSouth SPA Point to Point Network) to SMARTPath DS3 Transport service (a.k.a. BellSouth SPA DS3 Shared Ring) the capacity of the LightGate service (a.k.a. BellSouth Point to Point Network) is considered to be the quantity of DS3's activated on the LightGate service (a.k.a. BellSouth Point to Point Network).

For the purposes of determining a higher order of service, the following ranking will be used (Analog Voice Grade (a.k.a. BellSouth SPA DSO VG) services=lowest):

1. Analog Voice Grade (a.k.a. BellSouth SPA DSO VG) Services
2. DSO (a.k.a. BellSouth SPA DSO Digital Data) Services
3. DS1 (a.k.a. BellSouth DPA DS1) Services (described in 7.2.9 following)
4. SMARTPath service (a.k.a. BellSouth SPA DS1 Shared Ring) (described in 7.2.13 following)
5. LightGate service (a.k.a. BellSouth SPA Point to Point Network).
6. SMARTPath DS3 Transport Service (a.k.a. BellSouth SPA DS3 Shared Ring)

Customer requested conversion of any Special Access Service (a.k.a. BellSouth SPA) to the same or higher speed Fast Packet Access Service will be treated as an upgrade to a higher order of service and, as such, termination liability will not apply in accordance with regulations set forth herein.

ISSUED: JUNE 30, 2020

EFFECTIVE: JULY 15, 2020

ACCESS SERVICE

2 - General Regulations (Cont'd)

2.4 Payment Arrangements and Credit Allowances (Cont'd)

2.4.8 Optional Payment Plans (Cont'd)

(A) Channel Services Payment Plan (Cont'd)

(5) Moves of Service Under CSPP

- (a) Moves to a different building will be treated as a discontinuance and start of service and all associated nonrecurring charges will apply as stated in 7.4.5 except as provided in 2.4.8(A)(5)(c).
- (b) Moves of service within the same building, where otherwise permissible under the provisions of this tariff, will not constitute a disconnection of service for purposes of the application of termination liability charges. Nonrecurring charges specified in 7.4.5 are applicable.
- (c) Termination Liability Charges will not apply to customer requests for moves of service to a different building subject to the following conditions:

This provision is available only for Voice Grade service (a.k.a. BellSouth SPA DSO VG), Digital Data Access service (a.k.a. BellSouth SPA DSO Digital Data), DS1 High Capacity service (a.k.a. BellSouth SPA DS1) and Uncompressed Video service (a.k.a. BellSouth SPA Uncompressed Digital Video Network). Moves of other CSPP services are subject to the regulations included in 7.4.5 following.

ISSUED: JUNE 16, 2011

EFFECTIVE: JULY 1, 2011

ACCESS SERVICE

2 - General Regulations (Cont'd)

2.4 Payment Arrangements and Credit Allowances (Cont'd)

2.4.8 Optional Payment Plans (Cont'd)

(A) Channel Services Payment Plan (Cont'd)

(5) Moves of Service Under CSPP

(c) (Cont'd)

- The original and new premises locations must be in Company territory within the same state.
- The move from the original location to the new location must be completed within thirty days of the original premises disconnect date.
- No lapse in billing will occur for moves of service under CSPP.
- Orders to disconnect the existing service and reestablish it at the new location must be related together and received by the Company at the same time.
- Any rate elements or quantities for local channels, interoffice channels, and/or optional features and functions from the original location that are not reestablished at the new location will be subject to applicable Termination Liability Charges.
- Any additions made at the new location will be handled in accordance with 2.4.8(A)(3) preceding.
- All regulations and charges for changes made to the service coincident to the move will apply.
- All appropriate nonrecurring charges for moves of service as specified in 7.4.5 preceding will apply.
- Moves of service that involve a change from interstate to intrastate jurisdiction will not be treated as a disconnect of service with regard to termination liability charge application. The customer must subscribe to a payment arrangement offered in the appropriate intrastate tariff which is equal to or greater than the remaining contract period.

ISSUED: JANUARY 15, 2014

EFFECTIVE: JANUARY 16, 2014

ACCESS SERVICE

2 - General Regulations (Cont'd)

2.4 Payment Arrangements and Credit Allowances (Cont'd)

2.4.8 Optional Payment Plans (Cont'd)

(A) Channel Services Payment Plan (Cont'd)

(6) Requests for Changes in Length of Service Period

(a) Subsequent to the establishment of a CSPP arrangement, and prior to the completion of the selected service period for that arrangement, the CSPP arrangement may be replaced by a new CSPP arrangement at rates and charges in effect on the first day of service under the new CSPP arrangement, subject to the following conditions: (Tx)

- No credit will be given for payments made under the original CSPP arrangement, except for credits allowed under Sections 2.4.8(A)(9)(a) of this tariff.
- The service period selected for the new CSPP arrangement begins on the new CSPP effective date but not later than the expiration date of the CSPP being replaced.
- Nonrecurring charges will not be reapplied for existing services.
- If the new CSPP arrangement has a service period shorter in length than the time remaining under the service period for the existing CSPP arrangement, the change to the new CSPP arrangement constitutes a disconnection of the existing CSPP arrangement for which termination liability charges apply. (Tx)

(7) Renewal Options

(a) When a service period under an existing CSPP arrangement is completed, the customer may select a new CSPP arrangement at rates and charges in effect on the first day of service under the new CSPP arrangement, continue service under the month-to-month rates, or discontinue service with no termination liability charge. If the customer does not elect to either discontinue service or continue service under a new CSPP arrangement, service will be continued under month-to-month rates.

(Tx)
(Tx)

(x) Issued under authority of Special Permission No. 14-001 of the FCC in order to withdraw material filed under Transmittal No. 71 and suspended under Order DA-13-2349, released December 9, 2013, without its becoming effective and to restore currently effective material.

ISSUED: JUNE 30, 2020

EFFECTIVE: JULY 15, 2020

ACCESS SERVICE

2 - General Regulations (Cont'd)

2.4 Payment Arrangements and Credit Allowances (Cont'd)

2.4.8 Optional Payment Plans (Cont'd)

(A) Channel Services Payment Plan (Cont'd)

(7) Renewal Options (Cont'd)

- (b) Any new services added to a customer's network or changes to existing services at the time of renewal will be subject to all appropriate nonrecurring charges.
- (c) When a customer renews a CSPP arrangement, the rates and charges in effect on the first day of service of the renewal will apply.
- (d) Recognition of previous service will be given to customers who renew an existing CSPP arrangement, for the same or larger system(s) and all associated rate elements at the same location(s), provided that the length of the new CSPP arrangement is equal to or greater than the remaining service period of the original CSPP arrangement. Recognition of previous service will be given to LightGate CSPP customers who convert to TPP arrangements as described in 2.4.8(D) following provided the customer is the original customer of record at the time of transfer.
- (e) Recognition of previous service will be given to month-to-month customers with a service date of January 1, 1992, or later who convert to a CSPP arrangement, provided the minimum service period has been met. For customers whose service date is January 1, 1992 or earlier, recognition will be given for the previous service back to January 1, 1992. For customers whose service date is later than January 1, 1992, recognition for the previous service will be given back to the actual service date.
- (f) To determine the appropriate CSPP Payment Plan for the renewed arrangement, recognition of service will consist of the sum of months in service of the completed service arrangement and the sum of months of the proposed service period of the CSPP arrangement. For example, a CSPP arrangement for a 36 month service period under Plan A is renewed for 24 months with no changes at the end of the 36-month period. The sum of months for the completed and proposed service periods would equal 60 months and would be billed under Payment Plan B.

ISSUED: JUNE 30, 2020

EFFECTIVE: JULY 15, 2020

ACCESS SERVICE

2 - General Regulations (Cont'd)

2.4 Payment Arrangements and Credit Allowances (Cont'd)

2.4.8 Optional Payment Plans (Cont'd)

(A) Channel Services Payment Plan (Cont'd)

(7) Renewal Options (Cont'd)

(f) (Cont'd)

Another example is a month-to-month customer, in service for 15 months, who wishes to convert to a 60-month CSPP arrangement with no changes. The combined service period of the Month-to-Month arrangement and the CSPP arrangement is equal to 75 months, which would be billed under Payment Plan C.

(8) Transfer of Service

(a) Service transferred to a new customer at the same location in accordance with Section 2.1.2 preceding does not constitute a disconnect of service or a discontinuance of an existing CSPP arrangement.

(9) Prepayment

(a) Effective October 15, 2005, prepayment is not available for new CSPP arrangements.

(b) Upon entering into a CSPP arrangement, the customer may prepay the outstanding recurring monthly rates in whole or in part for all rate elements included in the CSPP arrangement. The Company retains full ownership for services in accordance with Section 2.4.6. The following conditions apply:

- A prepayment allowance will be applied to the amount prepaid for each given month equal to 0.6666% per month compounded monthly for the number of months the payment is advanced.
- The customer may elect the percentage of the monthly rates to be prepaid, provided however, the same percentage shall apply to all rate elements included in the CSPP arrangement for all months remaining in the service period.
- This same prepayment percentage will apply in the event the customer adds services to an existing CSPP arrangement subsequent to the establishment of the service.

ISSUED: JUNE 30, 2020

EFFECTIVE: JULY 15, 2020

ACCESS SERVICE

2 - General Regulations (Cont'd)

2.4 Payment Arrangements and Credit Allowances (Cont'd)

2.4.8 Optional Payment Plans (Cont'd)

(A) Channel Services Payment Plan (Cont'd)

(9) Prepayment (Cont'd)

(b) (Cont'd)

- When a customer who has prepaid recurring monthly rates replaces the existing CSPP arrangement with a new CSPP arrangement, the customer will be credited with that portion of the prepayment amount, representing a prepayment of the monthly recurring rates remaining in the existing CSPP arrangement.
- Customers who prematurely disconnect will have termination liability charges deducted from the unused prepaid balance. The remaining prepaid balance, if any, will be credited to their bill.

(B) Area Commitment Plan (ACP)

The Area Commitment Plan (ACP) allows customers who have obtained service on a month-to-month basis to receive reduced rates, in the form of ACP credits, in exchange for a commitment to maintain a level of service for a specified period of time. The terms of this plan apply to special access services or switched access services that are available under an ACP, except as noted in the rate regulations for a service.

Services included in a Channel Services Payment Plan (CSPP) and/or a Transport Payment Plan (TPP) may not be included in an ACP or vice versa.

The customer determines the commitment level of rate elements that will be included in an ACP, i.e., the customer will provide the number of commitment rate elements expressed as a whole number (e.g., 12 DS1 Local Channels). For example, a customer wishes to establish an ACP for all of his DS1 services that are billing on a month-to-month basis. The customer has 12 DS1 Local Channels and 6 DS1 Interoffice Channels that have a total of 90 Interoffice Channel miles. In this example, the quantity of commitment rate elements would be specified as 12 DS1 Local Channels and 90 Interoffice Channel miles. For interoffice channels, the commitment is based on a quantity of miles. When credits are applied to interoffice channel miles on a circuit, the customer automatically receives credit for the fixed rate element component of the interoffice channel. As a further example, this customer may desire to establish a commitment level only for a small portion of these DS1 services. In this case, the customer would specify the level that is desired (e.g., 1 DS1 Local Channel). ACP commitments are made on a regional basis, i.e., one commitment for all Company service areas.

(D) (This page filed under Transmittal No. 157)

ISSUED: OCTOBER 17, 2022

EFFECTIVE: NOVEMBER 1, 2022

ACCESS SERVICE

2 - General Regulations (Cont'd)

2.4 Payment Arrangements and Credit Allowances (Cont'd)

2.4.8 Optional Payment Plans (Cont'd)

(B) Area Commitment Plan (ACP) (Cont'd)

The Customer may choose any period of time between 24 and 72 months for the commitment.⁽¹⁾⁽³⁾ The applicable rate for use in the ACP calculation is the ACP rate selected commitment period. ACP commitment periods are offered as follows:

(N)

- ACP A, commitment periods may be selected from 24 months to 48 months in length.⁽²⁾⁽³⁾

(N)

- ACP B, commitment periods may be selected from 49 months to 72 months in length.⁽¹⁾⁽²⁾⁽³⁾

(N)

Each month the Telephone Company will determine the number of in-service rate elements, by type (Local Channel, Multiplexer or Channel Mileage), for which the Telephone Company will apply credits during the following month. The amount of any ACP credit will be based on the difference between the month-to-month rate and the associated ACP rate. Credit and shortfall calculations will be performed at the end of each month, and the resulting credit/shortfall amounts will be applied to the Customer's bill during the following month.

The Telephone Company will apply credits to Local Channel and Multiplexer rate elements, by applying the following steps in the following order:

1. Credits will be applied by state, in proportion to the percentage of the relevant rate element type purchased by the Customer in each state. For example, if a Customer purchases 40 percent of its Local Channels in Florida, then the Telephone Company will apply 40 percent of the Customer's ACP credits to Local Channels to Florida.
2. Within each state, Local Channel and Multiplexer credits will be applied by Rate Zone, beginning with Rate Zone 1 and proceeding to Zone 3.
3. Within each Rate Zone, credits will be applied according to the applicable monthly charge for each rate element, beginning with the highest billed rate elements and proceeding to the lowest billed rate elements.

⁽¹⁾ Effective May 15, 2015, Plan B commitment periods of 61 to 72 months will no longer be available. Plan B commitment periods from 49 to 60 months will continue to be available for new ACPs. There is no change for existing ACPs.

⁽²⁾ Effective on September 13, 2017, ACPs greater than 36-months for special access services are no longer available, including for any otherwise available conversions. Circuits already subject to an ACP greater than 36-months, as of September 13, 2017, will continue to be provided under the then-current ACP term for the remainder of that term.

⁽³⁾ Effective on November 1, 2022, all ACPs for High Capacity (a.k.a. BellSouth SPA High Capacity DS1 (a.k.a. BellSouth SPA DS1)), CSPPs of greater than 24 months for High Capacity (a.k.a. BellSouth SPA High Capacity DS1 (a.k.a. BellSouth SPA DS1)), SMARTPath Service (a.k.a. BellSouth SPA DS1 Shared Ring), and SMARTPath DS3 Transport Service (a.k.a. BellSouth SPA DS3 Shared Ring), and TPPs greater than 12 months for BellSouth DS1 Diverse Service and LightGate Systems (a.k.a. BellSouth SPA Point to Point Network), are no longer available, including for any otherwise available conversions. Circuits already subject to ACPs, CSPPs, and TPPs, as of November 1, 2022, will continue to be provided under the then-current term for the remainder of that term.

(N)

(N)

ISSUED: SEPTEMBER 17, 2015

EFFECTIVE: OCTOBER 2, 2015

ACCESS SERVICE

2 - General Regulations (Cont'd)

2.4 Payment Arrangements and Credit Allowances (Cont'd)

2.4.8 Optional Payment Plans (Cont'd)

(B) Area Commitment Plan (ACP) (Cont'd)

The Telephone Company will apply credits to mileage rate elements, by applying the following steps in the following order:

(N)

1. Credits will be applied by state, in proportion to the percentage of the relevant rate element type purchased by the customer in each state. For example, if a Customer purchases 40 percent of its Local Channels in Florida, then the Telephone Company will apply 40 percent of the Customer's ACP credits to channel mileage in Florida.
2. Within each state, credits will be applied beginning with the longest mileage circuit and proceeding to the shortest mileage circuit.
3. If circuits have the same mileage, credits will be applied by Rate Zone, beginning with Rate Zone 1 and proceeding to Zone 3.
4. Within a Rate Zone, credits will be applied according to the applicable monthly charge for each mileage rate element, beginning with the highest billed rate element and proceeding to the lowest billed rate element.

(N)

If the number of in-service rate elements is less than the commitment level, a shortfall charge will apply. The shortfall charge will be equal to the difference between the Customer's commitment level and the number of in-service rate elements of the relevant type (Local Channel, Multiplexer or Channel Mileage); multiplied by 50 percent of the ACP rate applicable to each rate element to which a shortfall charge is applied. To calculate shortfall charges, the Telephone Company will apply the ACP Plan B, Price Cap Zone 2 rate that is in effect on the billing date for the appropriate commitment period, i.e., the ACP rate that is effective at the end of each month for which the credit/shortfall calculations are performed.

(C)

(C)

Some material appearing on this page previously appeared on 3rd Revised Page 89.

ISSUED: JUNE 30, 2020

EFFECTIVE: JULY 15, 2020

ACCESS SERVICE

2 - General Regulations (Cont'd)

2.4 Payment Arrangements and Credit Allowances (Cont'd)

2.4.8 Optional Payment Plans (Cont'd)

(B) Area Commitment Plan (ACP) (Cont'd)

Services available under ACP and the ACP rates are specified in the rate regulations of the individual services.

Credit and shortfall amounts will be distributed to billing areas based on each billing area's portion of a Customer's regional ACP eligible in-service units. Each state in the region is considered to be one billing area.

Effective March 4, 2006, a Customer may have only one ACP. For Customers with multiple ACP commitments prior to March 4, 2006, upon expiration of the multiple commitments, only one ACP may be maintained. In those cases as of March 4, 2006, where the Customer has more than one ACP agreement, the credits and shortfall charges will be determined in chronological order, starting with the earliest agreement. For Interoffice Mileage Commitments under ACP, circuits will be assigned with the longest mileage circuit assigned first and continuing in descending order by circuit length until the number of circuits subscribed to are assigned starting with the earliest agreement.

The Customer may add or disconnect services as desired, subject to the minimum service periods set forth in Section 7.4.4 for special access services or as set forth in Section 6.7.2 for switched access services and subject to applicable nonrecurring charges. Credits for services under an ACP will be made at the circuit level.

(D)

(D)

(D)(This page filed under Transmittal No. 157)

ISSUED: JUNE 30, 2020

EFFECTIVE: JULY 15, 2020

ACCESS SERVICE

2 - General Regulations (Cont'd)

2.4 Payment Arrangements and Credit Allowances (Cont'd)

2.4.8 Optional Payment Plans (Cont'd)

(B) Area Commitment Plan (ACP) (Cont'd)

A customer may upgrade services under an ACP to a higher order of service¹, provided under an Optional Payment Plan (i.e., an ACP, a TPP, a FPSPP, a FSP or a CSPP arrangement) and request a reduction in his ACP commitment level without incurring a termination liability. The customer request for the services being upgraded from a lower order of service must be coordinated with the installation of the new service being upgraded to a higher order of service. A new ACP will be issued to reflect a new commitment level. The new commitment level must be equal to or greater than the current commitment level less the quantity of services upgraded.

Effective March 4, 2006, a customer desiring to increase a commitment level may update an existing ACP agreement to include the increased commitment level. The commitment period for the updated ACP agreement must be equal to or greater than the time remaining in the existing ACP agreement.

If during the commitment period, the customer desires to decrease its commitment level or period, the customer must enter into a new ACP agreement and terminate the existing ACP agreement(s). This will result in a termination liability to be calculated as follows:

The penalty for a decrease in the commitment level or commitment period, per unit decreased, will equal the ACP rate associated with the existing ACP agreement multiplied by the difference in months between the time the ACP agreement has been in effect and the minimal months of the existing agreement times a factor. The factor is 40 percent for agreements that have been in effect twelve months or less, or 20 percent for agreements that have been in effect longer than 12 months.

Changes in commitment periods within a plan (e.g., ACP B) do not constitute a change involving a termination liability.

In the case of a decrease in both a commitment level and commitment period, the termination liability will be calculated first for the reduction in level and then for the reduction in period based on the reduced level.

Note 1: Customer requested conversion of Special Access Service (a.k.a., BellSouth SPA) to the same or higher speed Fast Packet Access Service will be treated as an upgrade to a higher order of service.

ISSUED: DECEMBER 23, 2022

EFFECTIVE: JANUARY 1, 2023

ACCESS SERVICE

2.4 Payment Arrangements and Credit Allowances (Cont'd)

2.4.8 Optional Payment Plans (Cont'd)

(C) Fast Packet Services Payment Plan⁽¹⁾

(1) General

- (a) The regulations specified herein are applicable only to specific Fast Packet Access Services as indicated in the rate regulations for such services in Section 21 and Section 23 following.
- (b) The terms of this Fast Packet Services Payment Plan (SPP) apply to such specific Fast Packet Services except as noted in the rate regulations for the given service.
- (c) The Fast Packet SPP allows customers to pay stabilized monthly rates for fixed service periods selected by the customer. The two payment plans offered are as follows:
 - Payment Plan A, service periods may be selected from 12 months to 24 months in length.
 - Payment Plan B, service periods may be selected from 25 months to 48 months in length.
- (d) When the customer renews a Fast Packet SPP arrangement under 2.4.8(C)(7)(d) following and the sum of months is greater than the number of months for which the services is available under a Fast Packet SPP, the current rates for the longest payment plan available for that service will apply. For example, when the customer extends XAFRS beyond 48 months, Payment Plan B rates will apply.
- (e) When the customer orders service to be provided under a Fast Packet SPP arrangement, the customer must designate to the Company the payment plan and the service period desired, e.g., Plan B and 36 months.
- (f) Rates stabilized under a Fast Packet SPP arrangement are exempt from Telephone Company initiated increases, however, decreases for any rate element will automatically flow through to the customer.

⁽¹⁾ Exchange Access Frame Relay Service (a.k.a. BellSouth Exchange Access Frame Relay Service), BellSouth Exchange Access Asynchronous Transfer Mode Service, BellSouth Managed Shared Frame Relay Service, and BellSouth Managed Shared Asynchronous Transfer Mode Service have been discontinued and are no longer available in this publication (see WC Dkt. 11-120). (Z)

ISSUED: DECEMBER 23, 2022

EFFECTIVE: JANUARY 1, 2023

ACCESS SERVICE

2.4 Payment Arrangements and Credit Allowances (Cont'd)

2.4.8 Optional Payment Plans (Cont'd)

(C) Fast Packet Services Payment Plan⁽¹⁾ (Cont'd)

(2) Application of Rates and Charges

(a) The rates and charges applicable are those in effect as set forth in the rate regulations of this tariff for the particular Fast Packet Access Service involved as of the Application Date, provided that the actual service date does not exceed the later of the following.

(1) the Service Date under a standard service interval, or

(2) the earliest date on which service can reasonably be made available to the customer by the Telephone Company.

(b) If a customer desires a service date later than as provided in (a) preceding, the rates and charges in effect at the time of the actual service date are applicable.

(c) The customer will be required to pay a Termination Liability Charge in the event that all or any part of a service is disconnected at the customer's request prior to expiration of any selected payment period of greater than one month's duration except as specified in 2.4.8(C)(4) following.

(d) No Termination Liability Charge will apply.

(3) Additions

(a) Additions of services or rate elements (e.g., Network Interfaces) must be under a new Fast Packet SPP arrangement at rates and charges specified in 2.4.8(C)(2) preceding.

(b) Termination charges for premature disconnection of added contractual services will apply as set forth under Disconnects in 2.4.8(C)(4) following.

⁽¹⁾ Exchange Access Frame Relay Service (a.k.a. BellSouth Exchange Access Frame Relay Service), BellSouth Exchange Access Asynchronous Transfer Mode Service, BellSouth Managed Shared Frame Relay Service, and BellSouth Managed Shared Asynchronous Transfer Mode Service have been discontinued and are no longer available in this publication (see WC Dkt. 11-120). (Z)

ISSUED: DECEMBER 23, 2022

EFFECTIVE: JANUARY 1, 2023

ACCESS SERVICE

2.4 Payment Arrangements and Credit Allowances (Cont'd)

2.4.8 Optional Payment Plans⁽¹⁾ (Cont'd)

(C) Fast Packet Services Payment Plan (Cont'd)

(3) Additions (Cont'd)

- (c) Additions under Fast Packet SPP are exempt from Company-initiated rate changes for all payment periods longer than one month. However, decreases for any rate element will automatically flow through to the customer.

(4) Disconnects

- (a) When a service or rate element, included under a Fast Packet SPP arrangement, is disconnected prior to expiration of the selected service period, no Termination Liability Charge will apply.
- (b) When a tariffed service under a Fast Packet SPP arrangement is disconnected prior to the expiration of a selected service period, no Termination Liability Charge will apply.

Nonrecurring charges apply for the installation of the newly requested service. Termination liability charges may apply for changes to associated Special Access Services under an Optional Payment Plan as set forth in tariffs regulating those services.

⁽¹⁾ Exchange Access Frame Relay Service (a.k.a. BellSouth Exchange Access Frame Relay Service), BellSouth Exchange Access Asynchronous Transfer Mode Service, BellSouth Managed Shared Frame Relay Service, and BellSouth Managed Shared Asynchronous Transfer Mode Service have been discontinued and are no longer available in this publication (see WC Dkt. 11-120).

(Z)

ISSUED: DECEMBER 23, 2022

EFFECTIVE: JANUARY 1, 2023

ACCESS SERVICE

2.4 Payment Arrangements and Credit Allowances (Cont'd)

2.4.8 Optional Payment Plans (Cont'd)

(C) Fast Packet Services Payment Plan⁽¹⁾ (Cont'd)

(5) Moves of Service Under Fast Packet SPP

- (a) Termination Liability Charges will not apply to customer requests for moves of service under Fast Packet SPP from one location to another location.

⁽¹⁾ Exchange Access Frame Relay Service (a.k.a. BellSouth Exchange Access Frame Relay Service), BellSouth Exchange Access Asynchronous Transfer Mode Service, BellSouth Managed Shared Frame Relay Service, and BellSouth Managed Shared Asynchronous Transfer Mode Service have been discontinued and are no longer available in this publication (see WC Dkt. 11-120).

(Z)

ISSUED: DECEMBER 23, 2022

EFFECTIVE: JANUARY 1, 2023

ACCESS SERVICE

2.4 Payment Arrangements and Credit Allowances (Cont'd)

2.4.8 Optional Payment Plans (Cont'd)

(C) Fast Packet Services Payment Plan⁽¹⁾ (Cont'd)

(5) Moves of Service Under Fast Packet SPP (Cont'd)

- All regulations and charges for changes made to the service coincident to that move shall apply.
- Moves of service that involve a change of jurisdiction (e.g., interstate to intrastate) will not be treated as a disconnect of service with regard to Termination Liability Charge application. The customer must subscribe to a payment arrangement offered in the appropriate intrastate tariff which is equal to or greater than the remaining contract period.

(6) Requests for Changes in Length of Service Period

- (a) Subsequent to the establishment of a Fast Packet SPP arrangement and prior to the completion of the selected service period for that arrangement, the Fast Packet SPP arrangement may be replaced by a new Fast Packet SPP arrangement at rates and charges in effect on the first day of service under the new Fast Packet SPP arrangement, subject to the following conditions:
- No credit will be given for payments made under the original Fast Packet SPP arrangement except for credits allowed under Section 2.4.8(C)(9)(a) following.
 - The service period selected for the new Fast Packet SPP arrangement begins on the new Fast Packet SPP effective date but not later than the expiration date of the Fast Packet SPP being replaced.
 - Nonrecurring charges will not be reapplied for existing services.
 - If the new Fast Packet SPP arrangement has a service period shorter in length than the time remaining under the service period for the existing Fast Packet SPP arrangement, the change to the new Fast Packet SPP constitutes a disconnection of the existing Fast Packet SPP arrangement for which no Termination Liability Charges apply.

⁽¹⁾ Exchange Access Frame Relay Service (a.k.a. BellSouth Exchange Access Frame Relay Service), BellSouth Exchange Access Asynchronous Transfer Mode Service, BellSouth Managed Shared Frame Relay Service, and BellSouth Managed Shared Asynchronous Transfer Mode Service have been discontinued and are no longer available in this publication (see WC Dkt. 11-120).

(Z)

ISSUED: DECEMBER 23, 2022

EFFECTIVE: JANUARY 1, 2023

ACCESS SERVICE

2.4 Payment Arrangements and Credit Allowances (Cont'd)

2.4.8 Optional Payment Plans (Cont'd)

(C) Fast Packet Services Payment Plan⁽¹⁾ (Cont'd)

(7) Renewal Options

- (a) When a service period under an existing Fast Packet SPP arrangement is completed, the customer may select a new Fast Packet SPP arrangement at rates and charges in effect on the first day of service under the new Fast Packet SPP arrangement, continue service under the month-to-month rates, or discontinue service with no Termination Liability Charge. If the customer does not elect to either discontinue service or continue service under a new Fast Packet SPP arrangement, service will be continued under month-to-month rates.
- (b) Any new rate elements added to a customer's network or changes to existing services at the time of renewal will be subject to all appropriate nonrecurring charges.
- (c) When a customer renews a Fast Packet SPP arrangement, the rates and charges in effect on the first day of service of the renewal will apply.
- (d) Recognition of previous service will be given to customers who renew an existing Fast Packet SPP arrangement, for all associated rate elements at the same location(s), provided that the length of the new Fast Packet SPP arrangement is equal to or greater than the remaining service period of the original Fast Packet SPP arrangement.
- (e) Recognition of previous service back to the actual service date will be given to month-to-month customers who convert to a Fast Packet SPP arrangement.
- (f) To determine the appropriate Fast Packet SPP Payment Plan for the renewed arrangement, recognition of service will consist of the sum of months in service of the completed service arrangement and the sum of the months of the proposed service period of the Fast Packet SPP arrangement. For example, a Fast Packet SPP arrangement for a 24 month service period under Payment Plan A is renewed for 16 months with no changes at the end of the 24 month period. The sum of months for the completed and proposed service periods would equal 40 months and would be billed under Payment Plan B.

⁽¹⁾ Exchange Access Frame Relay Service (a.k.a. BellSouth Exchange Access Frame Relay Service), BellSouth Exchange Access Asynchronous Transfer Mode Service, BellSouth Managed Shared Frame Relay Service, and BellSouth Managed Shared Asynchronous Transfer Mode Service have been discontinued and are no longer available in this publication (see WC Dkt. 11-120). (Z)

ISSUED: DECEMBER 23, 2022

EFFECTIVE: JANUARY 1, 2023

ACCESS SERVICE

2.4 Payment Arrangements and Credit Allowances (Cont'd)

2.4.8 Optional Payment Plans (Cont'd)

(C) Fast Packet Services Payment Plan⁽¹⁾ (Cont'd)

(7) Renewal Options (Cont'd)

(f) (Cont'd)

Another example is a month-to-month customer, in service for 15 months, who wishes to convert to a 24-month Fast Packet SPP arrangement with no changes. The combined service period of the Month-to-Month arrangement and the Fast Packet SPP arrangement is equal to 39 months which would be billed under Payment Plan B.

(8) Transfer of Service

- (a) Service transferred to a new customer at the same location in accordance with 2.1.2 preceding does not constitute a disconnect of service or a discontinuance of an existing Fast Packet SPP arrangement.

(9) Prepayment

- (a) Effective October 15, 2005, prepayment is not available for new Fast Packet SPP arrangements.
- (b) Upon entering into a Fast Packet SPP arrangement, the customer may prepay the outstanding recurring monthly rates in whole or in part for all rate elements included in the Fast Packet SPP arrangement. The Company retains full ownership of services in accordance with 2.4.6, preceding. The following conditions apply:
- A prepayment allowance will be applied to the amount prepaid for each given month equal to 0.6666% per month compounded monthly for the number of months the payment is advanced.
 - The customer may elect the percentage of the monthly rates to be prepaid, provided however, the same percentage shall apply to all rate elements included in the Fast Packet SPP arrangement for all months remaining in the service period.
 - This same prepayment percentage will apply in the event the customer adds services to an existing Fast Packet SPP arrangement subsequent to the establishment of the service.

⁽¹⁾ Exchange Access Frame Relay Service (a.k.a. BellSouth Exchange Access Frame Relay Service), BellSouth Exchange Access Asynchronous Transfer Mode Service, BellSouth Managed Shared Frame Relay Service, and BellSouth Managed Shared Asynchronous Transfer Mode Service have been discontinued and are no longer available in this publication (see WC Dkt. 11-120).

(Z)

ISSUED: JANUARY 2, 2024

EFFECTIVE: JANUARY 17, 2024

ACCESS SERVICE

2 - General Regulations (Cont'd)

2.4 Payment Arrangements and Credit Allowances (Cont'd)

2.4.8 Optional Payment Plans (Cont'd)

(C) Fast Packet Services Payment Plan⁽¹⁾ (Cont'd')

(9) Prepayment (Cont'd)

- When a customer who has prepaid recurring monthly rates replaces the existing Fast Packet SPP arrangement with a new Fast Packet SPP arrangement, the customer will be credited with that portion of the prepayment amount, representing a prepayment of the monthly recurring rates remaining in the existing Fast Packet SPP arrangement.
- No Termination Liability Charge will apply to Customers who prematurely disconnect.

(D) Transport Payment Plan (TPP)

(1) General

- (a) The regulations and terms specified herein are applicable only to LightGate (a.k.a. BellSouth SPA Point to Point Network), BellSouth Dedicated Ring and/or BellSouth DS1 Diverse service Special Access (a.k.a. BellSouth SPA) services as indicated in the rate regulations in Sections 6 and 7 of this tariff.
- (b) The TPP allows customers to pay stabilized monthly rates for fixed service periods selected by the customer. The three payment plans offered are as follows:
 - Payment Plan A, service periods may be selected from 12 months to 36 months in length.⁽³⁾⁽⁵⁾
 - Payment Plan B, service periods may be selected from 37 months to 60 months in length.⁽²⁾⁽³⁾
 - Payment Plan C, service periods may be selected from 61 months to 96 months in length.⁽¹⁾⁽²⁾⁽³⁾

(N)

⁽¹⁾ Effective May 15, 2015, Plan C commitment periods of 62 to 96 months will no longer be available for new TPPs. A Plan C commitment period of 61 months will continue to be available for new TPPs. There is no change for existing TPPs.

⁽²⁾ Effective on September 13, 2017, TPPs greater than 36-months are no longer available for LightGate (a.k.a. BellSouth SPA Point to Point Network) service and BellSouth DS1 Diverse service, including for any otherwise available renewals, extensions or conversions. Circuits already subject to a TPP greater than 36-months, as of September 13, 2017, will continue to be provided under the then-current TPP term for the remainder of that term.

⁽³⁾ Effective on November 1, 2022, all ACPs for High Capacity (a.k.a. BellSouth SPA High Capacity DS1 (a.k.a. BellSouth SPA DS1)), CSPPs of greater than 24 months for High Capacity (a.k.a. BellSouth SPA High Capacity DS1 (a.k.a. BellSouth SPA DS1)), SMARTPath Service (a.k.a. BellSouth SPA DS1 Shared Ring), and SMARTPath DS3 Transport Service (a.k.a. BellSouth SPA DS3 Shared Ring), and TPPs greater than 12 months for BellSouth DS1 Diverse Service and LightGate Systems (a.k.a. BellSouth SPA Point to Point Network), are no longer available, including for any otherwise available conversions. Circuits already subject to ACPs, CSPPs, and TPPs, as of November 1, 2022, will continue to be provided under the then-current term for the remainder of that term.

⁽⁴⁾ Exchange Access Frame Relay Service (a.k.a. BellSouth Exchange Access Frame Relay Service), BellSouth Exchange Access Asynchronous Transfer Mode Service, BellSouth Managed Shared Frame Relay Service, and BellSouth Managed Shared Asynchronous Transfer Mode Service have been discontinued and are no longer available in this publication (see WC Dkt. 11-120).

⁽⁵⁾ Effective on January 17, 2024, all CSPP and TPPs term plans greater than month-to-month for High Capacity (a.k.a. BellSouth SPA High Capacity DS1 (a.k.a. BellSouth SPA DS1)), SMARTPath Service (a.k.a. BellSouth SPA DS1 Shared Ring), SMARTPath DS3 Transport Service (a.k.a. BellSouth SPA DS3 Shared Ring), BellSouth DS1 Diverse Service and LightGate Systems (a.k.a. BellSouth SPA Point to Point Network), are no longer available, including for any otherwise available conversions. Existing Term Plan Services on January 17, 2024, will continue to be provided for the remainder of the then-current terms.

(N)
|
(N)

ISSUED: JUNE 30, 2020

EFFECTIVE: JULY 15, 2020

ACCESS SERVICE
2 - General Regulations (Cont'd)

2.4 Payment Arrangements and Credit Allowances (Cont'd)

2.4.8 Optional Payment Plans (Cont'd)

(D) Transport Payment Plan (Cont'd)

(1) General (Cont'd)

(c) Conversions of existing CSPP arrangements for BellSouth DS1 Diverse service, LightGate (a.k.a. BellSouth SPA Point to Point Network), BellSouth Dedicated Ring service(s) to a TPP arrangement must be initiated by the customer.

(d) For conversions to the TPP arrangement, the number of months under the TPP arrangement must equal or exceed the number of months remaining under the CSPP arrangement.

(e) Termination liability charges and nonrecurring charges will not apply when a CSPP customer converts to a TPP arrangement.

(f) Intentionally left blank.

(T)

(g) When the customer orders service to be provided under a TPP arrangement, the customer must designate to the Telephone Company the payment plan desired.

(h) Rates stabilized under a TPP arrangement are exempt from Telephone Company initiated increases, however, decreases for any rate element will automatically be reflected in the rates charged to the customer.

(i) Conversions of BellSouth DS1 Diverse service and/or LightGate (a.k.a. BellSouth SPA Point to Point Network) TPP arrangements to a higher order of CSPP service are allowed.

(2) Application of Rates

(a) The stabilized monthly recurring rates as set forth in Sections 6, 7 and 29 following are set as of the Application Date for BellSouth DS1 Diverse service, LightGate (a.k.a. BellSouth SPA Point to Point Network) and/or BellSouth Dedicated Ring provided that the actual service date does not exceed the later of the following:

(1)

the Se

(2) the earliest date by which service can be made available to the customer by the Telephone Company.

ISSUED: JUNE 30, 2020

EFFECTIVE: JULY 15, 2020

ACCESS SERVICE
2 - General Regulations (Cont'd)

2.4 Payment Arrangements and Credit Allowances (Cont'd)

2.4.8 Optional Payment Plans (Cont'd)

(D) Transport Payment Plan (Cont'd)

(2) Application of Rates (Cont'd)

- (b) If the customer desires a service date later than as provided in (a) preceding, the stabilized monthly recurring rates in effect on the service date are applicable.

(3) Additions

- (a) Additions of services or rate elements, to existing BellSouth DS1 Diverse service to activate spare or unused capacities, must be activated under the same rate plan as the existing TPP arrangement. LightGate (a.k.a. BellSouth SPA Point to Point Network) and/or BellSouth Dedicated Ring channel interfaces must be activated as set forth in Sections 6 and 7 following.

(4) Disconnects

- (a) Except as provided in 2.4.8(D)(4)(b) through (f) following, when a BellSouth DS1 Diverse service, LightGate (a.k.a. BellSouth SPA Point to Point Network) and/or BellSouth Dedicated Ring rate element is disconnected prior to being in service for a 12-month period, (e.g., the minimum term for a Plan A TPP), the termination liability charge will be derived by multiplying the difference in rates between the current month-to-month rate and the rate for the TPP arrangement selected. For example, a customer subscribes to a TPP for 24 months (Plan A) and terminates service after 10 months. The termination liability charge will be applied by multiplying the number of months in service (10) by the difference between the month-to-month and Plan A monthly rates. With the exception of Renewal Options in 2.4.8(D)(7) following, a four month minimum service period for BellSouth DS1 Diverse service, LightGate (a.k.a. BellSouth SPA Point to Point Network) and/or BellSouth Dedicated Ring will be applicable and all month-to-month regulations will apply.

ISSUED: JUNE 30, 2020

EFFECTIVE: JULY 15, 2020

ACCESS SERVICE

2 - General Regulations (Cont'd)

2.4 Payment Arrangements and Credit Allowances (Cont'd)

2.4.8 Optional Payment Plans (Cont'd)

(D) Transport Payment Plan (Cont'd)

(4) Disconnects (Cont'd)

When a BellSouth DS1 Diverse service, LightGate (a.k.a. BellSouth SPA Point to Point Network) or BellSouth Dedicated Ring TPP customer disconnects a rate element prior to the 12 month TPP minimum, all current month-to-month nonrecurring charges associated with the BellSouth DS1 Diverse service, LightGate (a.k.a. BellSouth SPA Point to Point Network) system or BellSouth Dedicated Ring level rate elements will apply.

ISSUED: JUNE 30, 2020

EFFECTIVE: JULY 15, 2020

ACCESS SERVICE

2 - General Regulations (Cont'd)

2.4 Payment Arrangements and Credit Allowances (Cont'd)

2.4.8 Optional Payment Plans (Cont'd)

(D) Transport Payment Plan (Cont'd)

(4) Disconnects (Cont'd)

(a) (Cont'd)

BellSouth DS1 Diverse service rate elements are defined as Local and Interoffice Channels. LightGate system (a.k.a. BellSouth SPA Point to Point Network) rate elements are defined as LightGate (a.k.a. BellSouth SPA Point to Point Network) service Local and Interoffice Channel Systems including SAFT Levels I and II. BellSouth Dedicated Ring rate elements are defined as following: Local Channel, Interoffice Channel, Internodal Channel, Alternate Central Office Channel, Customer Node and Central Office Node.

- (b) Except as provided in Section 2.4.8(D)4 (c) through (f) following, when a BellSouth DS1 Diverse service, LightGate (a.k.a. BellSouth SPA Point to Point Network) or BellSouth Dedicated Ring TPP customer disconnects services or rate elements prior to the minimum number of months for the plan period selected, termination liability charges will apply. The termination liability charge will be derived at the time of disconnection by taking the difference between the rate for the TPP period for which the customer subscribed, and the rate for the TPP period that the customer's completed service would otherwise qualify, and multiplying the difference by the number of months service the customer completed under a TPP. For example, a customer subscribes to a TPP for 73 months (Plan C) and terminates service after 20 months (Plan A). The termination liability charge will be applied by multiplying the number of months in service (20) by the difference between the Plan A and Plan C monthly rates. When a BellSouth DS1 Diverse service, LightGate (a.k.a. BellSouth SPA Point to Point Network) or BellSouth Dedicated Ring customer disconnects service after the minimum number of months for the TPP arrangement selected but prior to the actual expiration date of the TPP arrangement, termination liability charges do not apply.

ISSUED: JANUARY 15, 2014

EFFECTIVE: JANUARY 16, 2014

ACCESS SERVICE

2 - General Regulations (Cont'd)

2.4 Payment Arrangements and Credit Allowances (Cont'd)

2.4.8 Optional Payment Plans (Cont'd)

(D) Transport Payment Plan (Cont'd)

(4) Disconnects (Cont'd)

(c) When a TPP arrangement is disconnected prior to the expiration of a plan period due to a customer requested change to a higher order of service at the same location, or to expand or upgrade an existing service, termination liability charges will not apply when:

- (1) the customer has completed at least 6 months of the originally selected TPP service period, and
- (2) the service period of the new arrangement for the new service is equal to or longer than the remaining service period of the disconnected arrangement, and
- (3) the service orders to install the new service and disconnect the old service are related together and received by the Telephone Company at the same time, and there is no lapse in service between installation of the higher order of service and disconnection of the existing service, and

(Tx)

(Tx)
(Tx)

(x) Issued under authority of Special Permission No. 14-001 of the FCC in order to withdraw material filed under Transmittal No. 71 and suspended under Order DA-13-2349, released December 9, 2013, without its becoming effective and to restore currently effective material.

ISSUED: DECEMBER 23, 2022

EFFECTIVE: JANUARY 1, 2023

ACCESS SERVICE

2 - General Regulations (Cont'd)

2.4 Payment Arrangements and Credit Allowances (Cont'd)

2.4.8 Optional Payment Plans (Cont'd)

(D) Transport Payment Plan (Cont'd)

(4) Disconnects (Cont'd)

(c) (Cont'd)

- (4) the capacity of the new service is equal to or greater than the existing service. For converting LightGate service (a.k.a. BellSouth SPA Point to Point Network) to SMARTPath DS3 Transport service (a.k.a. BellSouth SPA DS3 Shared Ring), the capacity of the LightGate service (a.k.a. BellSouth SPA Point to Point Network) is considered to be the quantity of DS3s activated on the LightGate service (a.k.a. BellSouth SPA Point to Point Network).

For the purposes of determining a higher order of service in all payment plans, the following ranking will be used (Analog Voice Grade (a.k.a. BellSouth SPA DSO VG) service=lowest, Telephone Company dedicated ring service=highest):

1. Analog Voice Grade (a.k.a. BellSouth SPA DSO VG) services
2. DSO (a.k.a. BellSouth SPA DSO Digital Data) Services DS1 (a.k.a. BellSouth SPA DS1) Services BellSouth DS1 Diverse Service SMARTPath service (a.k.a. BellSouth SPA DS1 Shared Ring)
6. Telephone Company wavelength service/Telephone Company wavelength channel service with stand alone channels⁽¹⁾
7. LightGate service (a.k.a. BellSouth SPA Point to Point Network)/Telephone Company wavelength channel service dedicated system arrangements
8. SMARTPath DS3 Transport service (a.k.a. BellSouth SPA DS3 Shared Ring)
9. BellSouth Dedicated Ring/Telephone Company wavelength dedicated ring service (see Section 2.4.8(D)(4)(f))

Customer requested conversion of Special Access Service (a.k.a., BellSouth SPA) to the same or higher speed Fast Packet Access Service⁽¹⁾ will be treated as an upgrade to a higher order of service and, as such, termination liability will not apply in accordance with regulations set forth herein.

⁽¹⁾ Exchange Access Frame Relay Service (a.k.a. BellSouth Exchange Access Frame Relay Service), BellSouth Exchange Access Asynchronous Transfer Mode Service, BellSouth Managed Shared Frame Relay Service, and BellSouth Managed Shared Asynchronous Transfer Mode Service have been discontinued and are no longer available in this publication (see WC Dkt. 11-120).

(Z)

ISSUED: JUNE 30, 2020

EFFECTIVE: JULY 15, 2020

ACCESS SERVICE

2 - General Regulations (Cont'd)

2.4 Payment Arrangements and Credit Allowances (Cont'd)

2.4.8 Optional Payment Plans (Cont'd)

(D) Transport Payment Plan (Cont'd)

(4) Disconnects (Cont'd)

- (d) A termination liability charge will not apply to disconnects of channel interfaces associated with LightGate (a.k.a. BellSouth SPA Point to Point Network) and/or BellSouth Dedicated Ring.
- (e) Disconnects, moves, or rearrangements involving the removal of the following BellSouth Dedicated Ring rate elements, local channel, interoffice channel, customer node and central office node, to allow the placement of additional nodes and channels for existing customers where the total number of nodes does not decrease, will not be subject to termination liability charges.

ISSUED: JUNE 30, 2020

EFFECTIVE: JULY 15, 2020

ACCESS SERVICE
2 - General Regulations

2.4 Payment Arrangements and Credit Allowances (Cont'd)

2.4.8 Optional Payment Plans (Cont'd)

(D) Transport Payment Plan (Cont'd)

(4) Disconnects (Cont'd)

(f) A change of jurisdiction from interstate to intrastate service constitutes a disconnection of service for which termination charges are applicable. However, if such service continues between the same serving locations, and the customer enters into a new TPP arrangement in the intrastate jurisdiction for the same or larger service capacity and associated rate elements for a service period equal to or greater than the service period remaining under the interstate TPP arrangement, no interstate termination liability charge will be applicable.

(5) Moves of Service Under TPP

(a) Moves to a different building will be treated as a discontinuance and start of service and all associated nonrecurring charges will apply as stated in 7.4.5, 7.5.9, 23.5, 29.1.7 and 29.1.9 except as provided in 2.4.8(D)(5)(c) following. A four month minimum service period must be satisfied for all service rate elements serving the original building location.

(b) Moves of service within the same building will not constitute a disconnection of service for purposes of the application of termination liability charges. Current month-to-month nonrecurring charges specified in 7.4.5, 7.5.9, 23.5, 29.1.7 and 29.1.9 are applicable.

(c) Termination Liability Charges will not apply to customer requests for moves of service to a different building subject to the following conditions:

- The move from the original location to the new location must be completed within thirty days of the original premises disconnect date.
- The move is a result of connecting one existing LightGate point of termination to a Telephone Company dedicated ring service. For all other LightGate systems, the new customer premises must be served by the same serving wire center as the original location.
- No lapse in billing will occur for moves of service under a TPP arrangement.
- Orders to disconnect the existing service and reestablish it at the new location must be related together and received by the Telephone Company at the same time.

(D)(This page filed under Transmittal No. 157)

ISSUED: JUNE 30, 2020

EFFECTIVE: JULY 15, 2020

ACCESS SERVICE

2 - General Regulations (Cont'd)

2.4 Payment Arrangements and Credit Allowances (Cont'd)

2.4.8 Optional Payment Plans (Cont'd)

(D) Transport Payment Plan (Cont'd)

(5) Moves of Service Under TPP (Cont'd)

(c) (Cont'd)

- Any additions made at the new location will be handled in accordance with (3) preceding.
- All regulations and charges for changes made to the service coincident with the move will apply.
- All appropriate nonrecurring charges for moves of service as specified in 7.4.5, 7.5.9 and 23.5 following will apply.

Any rate elements or quantities for local channels, interoffice channels or optional features and functions from the original location that are not reestablished at the new location will be subject to applicable Termination Liability Charges.

(6) Requests for Changes in Length of Service Period

(a) Subsequent to the establishment of a TPP arrangement, and prior to the completion of the selected service period for that arrangement, the TPP arrangement may be replaced by a new TPP arrangement at rates and charges in effect on the first day of service under the new TPP arrangement, subject to the following conditions:

- No credit will be given for payments made under the original TPP arrangement, except for credits allowed under 2.4.8(D)(9)(A) following.
- The service period selected for the new TPP arrangement begins on the new TPP effective date but not later than the expiration date of the TPP being replaced.
- Nonrecurring charges do not apply for existing services.

ISSUED: JUNE 30, 2020

EFFECTIVE: JULY 15, 2020

ACCESS SERVICE

2 - General Regulations (Cont'd)

2.4 Payment Arrangements and Credit Allowances (Cont'd)

2.4.8 Optional Payment Plans (Cont'd)

(D) Transport Payment Plan (Cont'd)

(6) Requests for Changes in Length of Service Period (Cont'd)

(a) (Cont'd)

If the new TPP arrangement has a service period shorter in length than the time remaining under the service period for the existing TPP arrangement, the change to the new TPP arrangement constitutes a disconnection of the existing TPP arrangement for which termination liability charges apply.

(b) Subsequent to the establishment of a TPP arrangement, and prior to the completion of the selected service period for that arrangement, the TPP arrangement may be extended⁽¹⁾ subject to the following conditions:

- The start date of the TPP is not changed, however, with an extension the customer selects a new TPP service period (i.e., the number of months associated with the customer's TPP) that is greater than what presently exist for the current TPP.
- The maximum service period that may be selected for an extension is 96 months. After 96 months, a customer must establish a new TPP arrangement.
- If the new service period selected with an extension results in a change of Payment Plans, then the rates associated with the new Payment Plan will be effective on the first day of service under the extended TPP. For example, if a customer presently has a 36-month TPP arrangement, which is associated with Payment Plan A rates, and extends his service period to 61 months, which is associated with Payment Plan C rates, the Plan C rates will be effective on the first day of the extended TPP.
- If a TPP arrangement that has been extended is disconnected prior the expiration of the extended service period, termination liability charges will be based on the rates associated with the extended TPP arrangement at the time of the disconnect. For example, if a customer's TPP that has been extended and is receiving Plan C rates at the time the TPP is disconnected, then Plan C rates will be used to determine the applicable termination liability.

⁽¹⁾ Term extensions are not available for TPPs established on or after May 15, 2015. There is no change for existing TPPs.

ISSUED: JUNE 30, 2020

EFFECTIVE: JULY 15, 2020

ACCESS SERVICE

2 - General Regulations (Cont'd)

2.4 Payment Arrangements and Credit Allowances (Cont'd)

2.4.8 Optional Payment Plans (Cont'd)

(D) Transport Payment Plan (Cont'd)

(7) Renewal Options

- (a) When a service period under an existing CSPP or TPP arrangement is completed, the customer may select a new TPP arrangement at rates and charges in effect on the first day of service under the new TPP arrangement, continue service under the month-to-month rates, or discontinue service with no termination liability charge. If the customer does not elect to either discontinue service or continue service under a new TPP arrangement, service will be continued under month-to-month rates. The TPP customer of record will have a 60-day grace period after which current month-to-month rates will apply. The stabilized monthly recurring rates as set forth in Sections 7 and 29 following remain in effect during the 60-day grace period.
- (b) Any new services added to a customer's network or changes to existing services at the time of renewal will be subject to all appropriate nonrecurring charges and four month minimum service period requirements.
- (c) When a customer renews a TPP arrangement, the rates and charges in effect on the first day of service of the renewal will apply.
- (d) To determine the appropriate TPP Payment Plan for the renewed arrangement, recognition of service will consist of the sum of months in service of the completed service arrangement and the sum of months of the proposed service period of the TPP arrangement.
- (e) Recognition of previous service will be given to customers who renew an existing TPP arrangement, for the same or larger system(s) and all associated rate elements at the same location(s), provided that the length of the new TPP arrangement is equal to or greater than the remaining service period of the original TPP arrangement. Recognition for satisfying the four month service period as appropriate for the service will be given for renewals of the same size channels, systems, rings, and all associated rate elements. Conversion to larger systems and rings will incur new four month minimum service requirements.

ISSUED: JUNE 30, 2020

EFFECTIVE: JULY 15, 2020

ACCESS SERVICE

2 - General Regulations (Cont'd)

2.4 Payment Arrangements and Credit Allowances (Cont'd)

2.4.8 Optional Payment Plans (Cont'd)

(D) Transport Payment Plan (Cont'd)

(7) Renewal Options (Cont'd)

- (f) Recognition of previous service will be given to month-to-month customers who convert to a TPP arrangement, for the same or larger system(s) and all associated rate elements at the same location(s), provided the four month minimum service period for that service has been met.
- (g) Recognition of previous service will be given to TPP customers who convert from CSPP arrangements provided the customer is the original customer of record at the time of transfer.
- (h) When an existing BellSouth DS1 Diverse service, LightGate (a.k.a. BellSouth SPA Point to Point Network), and/or BellSouth Dedicated Ring, customer has completed the selected TPP commitment period and the service reverts to month-to-month service, only the contiguous month-to-month service adjacent to the start date of the new TPP will receive recognition for determining the appropriate TPP arrangement or any subsequent TPP arrangement.

(8) Transfer of Service

- (a) Service transferred to a new customer at the same location in accordance with 2.1.2 preceding does not constitute a disconnect of service or a discontinuance of an existing TPP arrangement.

(9) Prepayment

- (a) Effective October 15, 2005, prepayment is not available for new TPP arrangements.
- (b) Upon entering into a TPP arrangement, the customer may prepay the outstanding recurring monthly rates in whole or in part for all rate elements included in the TPP arrangement. The following conditions apply:

ISSUED: JUNE 16, 2011

EFFECTIVE: JULY 1, 2011

ACCESS SERVICE

2 - General Regulations (Cont'd)

2.4 Payment Arrangements and Credit Allowances (Cont'd)

2.4.8 Optional Payment Plans (Cont'd)

(D) Transport Payment Plan (Cont'd)

(9) Prepayment (Cont'd)

- A prepayment allowance will be applied to the amount prepaid for each given month equal to 0.6666% per month compounded monthly for the number of months the payment is advanced.
- The customer may elect the percentage of the monthly rates to be prepaid, provided however, the same percentage shall apply to all rate elements included in the TPP arrangement for all months remaining in the service period.
- This same prepayment percentage will apply in the event the customer adds services to an existing TPP arrangement subsequent to the establishment of the service.
- When a customer who has prepaid recurring monthly rates replaces the existing TPP arrangement with a new TPP arrangement, the customer will be credited with that portion of the prepayment amount, representing a prepayment of the monthly recurring rates remaining in the existing TPP arrangement.
- Customers who disconnect service and incur termination liability charges, such charges shall be deducted from the unused prepaid balance. The remaining prepaid balance, if any, will be credited to their bill.

(10) Automatic Extension of TPP Arrangements

- (a) For the period beginning on January 13, 2001 through January 12, 2002, customers that complete a TPP arrangement will receive an automatic 12-month extension of their TPP arrangement. With this automatic extension, the customer's service will be continued under TPP at the rates and charges associated with the payment plan that is being extended. Customers that do not wish to utilize the benefits of the automatic extension may request that their TPP arrangement be terminated, without penalty, at any time during the 12-month period associated with their extension.

At the end of the 12-month extension, or at the time that a customer indicates that they do not desire to continue under the 12-month extension, the standard provisions associated with the completion of a TPP arrangement apply.

ISSUED: JUNE 30, 2020

EFFECTIVE: JULY 15, 2020

ACCESS SERVICE

2 - General Regulations (Cont'd)

2.4 Payment Arrangements and Credit Allowances (Cont'd)

2.4.8 Optional Payment Plans (Cont'd)

(E) Intentionally left blank.

(T)

ISSUED: JUNE 30, 2020

EFFECTIVE: JULY 15, 2020

ACCESS SERVICE

2 - General Regulations (Cont'd)

2.4 Payment Arrangements and Credit Allowances (Cont'd)

2.4.8 Optional Payment Plans (Cont'd)

(E) Intentionally left blank.

(T)

(D) (This page filed under Transmittal No. 157)

ISSUED: JUNE 30, 2020

EFFECTIVE: JULY 15, 2020

ACCESS SERVICE

2 - General Regulations (Cont'd)

2.4 Payment Arrangements and Credit Allowances (Cont'd)

2.4.8 Optional Payment Plans (Cont'd)

(E) Intentionally left blank.

(T)

ISSUED: AUGUST 23, 2012

EFFECTIVE: SEPTEMBER 7, 2012

ACCESS SERVICE

2 - General Regulations (Cont'd)

2.4 Payment Arrangements and Credit Allowances (Cont'd)

2.4.8 Optional Payment Plans (Cont'd)

(E)

(D)

(D)

ISSUED: AUGUST 23, 2012

EFFECTIVE: SEPTEMBER 7, 2012

ACCESS SERVICE

2 - General Regulations (Cont'd)

2.4 Payment Arrangements and Credit Allowances (Cont'd)

2.4.8 Optional Payment Plans (Cont'd)

(E)

(D)

(D)

BELLSOUTH TELECOMMUNICATIONS
Four AT&T Plaza, Dallas, Texas 75202

TARIFF F.C.C. NO. 1
1ST REVISED PAGE 2-118
CANCELS ORIGINAL PAGE 2-118

ISSUED: AUGUST 23, 2012

EFFECTIVE: SEPTEMBER 7, 2012

ACCESS SERVICE

2 - General Regulations (Cont'd)

2.4 Payment Arrangements and Credit Allowances (Cont'd)

2.4.8 Optional Payment Plans (Cont'd)

(E)

(D)

(D)

ISSUED: DECEMBER 23, 2022

EFFECTIVE: JANUARY 1, 2023

ACCESS SERVICE

2 - General Regulations (Cont'd)

2.4 Payment Arrangements and Credit Allowances (Cont'd)

2.4.8 Optional Payment Plans (Cont'd)

(F) BellSouth Fast Packet Savings Plan⁽³⁾

Effective September 29, 2007, the BellSouth Fast Packet Savings Plan (FSP) will no longer be available for new customer subscriptions. Existing FSP customers may keep their existing FSP agreements until the expiration of the term. Upon expiration of the term, customers may not renew the FSP agreement. Also with the above effective date, customers may not revise an existing FSP agreement to extend the length of the term.

- (1) The BellSouth FSP allows customers to receive credits applied to their bill in exchange for making a commitment to maintain a minimum level of total Fast Packet Services monthly recurring billing (defined in 2.4.8(F)(3) following) for a specified period of time.

The credits provided under a BellSouth FSP agreement are applied to eligible Fast Packet Services, LightGate service (a.k.a. BellSouth SPA Point to Point). The monthly rates and nonrecurring charges¹ for the following Fast Packet Services, LightGate service (a.k.a. BellSouth SPA Point to Point) are eligible for credit when subscribed to on a month-to-month basis:

- BellSouth Exchange Access Frame Relay Service⁽²⁾⁽³⁾
- BellSouth Managed Shared Frame Relay Service⁽²⁾⁽³⁾
- BellSouth Customer Network Management - Network Visibility Service (CNM-NVS) (excluding Service Establishment Charge and Management Access Interface Charges)
- LightGate service (a.k.a. BellSouth SPA Point to Point)

⁽¹⁾ Effective November 14, 2001, FSP discount credits also apply to nonrecurring billing for eligible services for a customer under a FSP agreement. For a customer with an existing FSP agreement, FSP credit adjustments are not applicable for nonrecurring billing prior to November 14, 2001.

⁽²⁾ Effective November 5, 2011, Exchange Access Frame Relay Service (XAFRS) (a.k.a. BellSouth Exchange Access Frame Relay Service) as described in Section 21.2, following, and BellSouth Managed Shared Frame Relay Service (MSFRS) as described in 21.3, following, will no longer be available to new Customers. Existing term plan Customers, as of November 5, 2011, may add, move, remove or change lines and/or locations for the durations of their current term plan agreements, but may not enter into any new term plan agreements. Existing Customers will be permitted one extension of any existing, non-expired term plan agreement past its current term for twelve (12) months, provided the extension is signed on or before March 31, 2012. Upon expiration of any term plan agreement (including any permitted extension), service will continue on a month-to-month basis until the service is discontinued by the Telephone Company.

⁽³⁾ Exchange Access Frame Relay Service (a.k.a. BellSouth Exchange Access Frame Relay Service), BellSouth Exchange Access Asynchronous Transfer Mode Service, BellSouth Managed Shared Frame Relay Service, and BellSouth Managed Shared Asynchronous Transfer Mode Service have been discontinued and are no longer available in this publication (see WC Dkt. 11-120). (Z)

ISSUED: DECEMBER 23, 2022

EFFECTIVE: JANUARY 1, 2023

ACCESS SERVICE

2 - General Regulations (Cont'd)

2.4 Payment Arrangements and Credit Allowances (Cont'd)

2.4.8 Optional Payment Plans (Cont'd)

(F) BellSouth Fast Packet Savings Plan⁽¹⁾ (Cont'd)

(2) The Fast Packet services as set forth in 2.4.8(F)(1) preceding that are included in a Fast Packet Services Payment Plan (FPSP, as provided in 2.4.8(C)) will not receive BellSouth FSP credits. Monthly recurring billing for such services under a Fast Packet Services Payment Plan shall, however, count towards the customer's Total Fast Packet Services Monthly Recurring Billing (referred to as qualifying revenues) for a BellSouth FSP as set forth in 2.4.8(F)(3) following.

The LightGate service (a.k.a. BellSouth SPA Point to Point), as set forth in 2.4.8(D)(1) preceding that are included in a Transport Payment Plan (TPP), as provided in 2.4.8(D), will not receive BellSouth FSP credits. Monthly recurring billing for such services shall, however, count towards the customer's Total Fast Packet Services Monthly Recurring Billing (referred to as qualifying revenues) for a BellSouth FSP as set forth in 2.4.8(F)(3) following.

⁽¹⁾ Exchange Access Frame Relay Service (a.k.a. BellSouth Exchange Access Frame Relay Service), BellSouth Exchange Access Asynchronous Transfer Mode Service, BellSouth Managed Shared Frame Relay Service, and BellSouth Managed Shared Asynchronous Transfer Mode Service have been discontinued and are no longer available in this publication (see WC Dkt. 11-120).

(Z)

ISSUED: DECEMBER 23, 2022

EFFECTIVE: JANUARY 1, 2023

ACCESS SERVICE

2 - General Regulations (Cont'd)

2.4 Payment Arrangements and Credit Allowances (Cont'd)

2.4.8 Optional Payment Plans (Cont'd)

(F) BellSouth Fast Packet Savings Plan⁽³⁾ (Cont'd)

(3) The customer's Total Fast Packet Services Monthly Recurring Billing, referred to hereafter as qualifying revenues, will be utilized to establish the appropriate BellSouth FSP credit schedule which will be applied to the customer's eligible Fast Packet Service billing as set forth in Section 2.4.8(F)(1). A customer's qualifying revenues is defined to include their monthly recurring billing¹ for the following services:

- Eligible Fast Packet Services (as set forth in Section 2.4.8(F)(1))
- BellSouth Exchange Access Frame Relay Service⁽²⁾ under FPSPP
- Eligible BellSouth Transport Services (per (a) following):
 - § WATS Access Line (WAL) (a.k.a. BellSouth WATS Line) Service
 - § DS1 High Capacity (a.k.a. BellSouth SPA DS1) Service
 - § High Capacity (a.k.a. BellSouth SPA High Capacity)
 - § Alternate Serving Wire Center Service
 - § LightGate Service (a.k.a. BellSouth SPA Point to Point Network)
 - § Digital Data Access Service (a.k.a. BellSouth SPA DS0 Digital Data)
 - § Voice Grade (a.k.a. BellSouth SPA DS0 VG) Service
 - § Program Audio⁽⁴⁾ (a.k.a. BellSouth SPA Program Audio) Service
 - § Analog Data Access (a.k.a. BellSouth SPA DS0 VG) Service
 - § SMARTPath Service (a.k.a. BellSouth SPA DS1 Shared Ring)
 - § SMARTPath DS3 Transport Service (a.k.a. BellSouth SPA DS3 Shared Ring)

⁽¹⁾ While nonrecurring charges for eligible services receive discounts under an FSP agreement, nonrecurring charge billing does not count as "qualifying" revenue towards a customer's minimum monthly revenue commitment.

⁽²⁾ Effective November 5, 2011, Exchange Access Frame Relay Service (XAFRS) (a.k.a. BellSouth Exchange Access Frame Relay Service) as described in Section 21.2, will no longer be available to new Customers. Existing term plan Customers, as of November 5, 2011, may add, move, remove or change lines and/or locations for the durations of their current term plan agreements, but may not enter into any new term plan agreements. Existing Customers will be permitted one extension of any existing, non-expired term plan agreement past its current term for twelve (12) months, provided the extension is signed on or before March 31, 2012. Upon expiration of any term plan agreement (including any permitted extension), service will continue on a month-to-month basis until the service is discontinued by the Telephone Company.

⁽³⁾ Exchange Access Frame Relay Service (a.k.a. BellSouth Exchange Access Frame Relay Service), BellSouth^(Z) Exchange Access Asynchronous Transfer Mode Service, BellSouth Managed Shared Frame Relay Service, and BellSouth Managed Shared Asynchronous Transfer Mode Service have been discontinued and are no longer available in this publication (see WC Dkt. 11-120).

⁽⁴⁾ Program Audio is discontinued and no longer available in this publication (see WC Dkt. 19-238).

ISSUED: DECEMBER 23, 2022

EFFECTIVE: JANUARY 1, 2023

ACCESS SERVICE

2 - General Regulations (Cont'd)

2.4 Payment Arrangements and Credit Allowances (Cont'd)

2.4.8 Optional Payment Plans (Cont'd)

(F) BellSouth Fast Packet Savings Plan⁽¹⁾ (Cont'd)

(3) (Cont'd)

- Eligible BellSouth Transport Services (per (a) following): (Cont'd)
 - § BellSouth SPA Customer Network Management (CNM) - FlexServ Service
 - § Surcharge for Special Access (a.k.a. BellSouth SPA) Service
 - § Message Station Equipment Recovery Charge
 - § Metallic (a.k.a. BellSouth Metallic) Service
 - § Telegraph Grade (a.k.a. BellSouth Telegraph) Service
 - § Derived Data Channel (a.k.a. BellSouth SPA Derived Data Channel) Service
 - § Video (a.k.a. BellSouth Video Service)
 - § Broadcast Quality Video (a.k.a. BellSouth SPA Broadcast Quality Video) Service
 - § Uncompressed Switched Video (a.k.a. BellSouth SPA Uncompressed Switched Video) Service
 - § BellSouth SPA Modular Video Transport Service
 - § Dry Fiber

⁽¹⁾ Exchange Access Frame Relay Service (a.k.a. BellSouth Exchange Access Frame Relay Service), BellSouth Exchange Access Asynchronous Transfer Mode Service, BellSouth Managed Shared Frame Relay Service, and BellSouth Managed Shared Asynchronous Transfer Mode Service have been discontinued and are no longer available in this publication (see WC Dkt. 11-120).

(Z)

ISSUED: DECEMBER 23, 2022

EFFECTIVE: JANUARY 1, 2023

ACCESS SERVICE

2 - General Regulations (Cont'd)

2.4 Payment Arrangements and Credit Allowances (Cont'd)

2.4.8 Optional Payment Plans (Cont'd)

(F) BellSouth Fast Packet Savings Plan⁽²⁾ (Cont'd)

(3) (Cont'd)

- Eligible BellSouth Transport Services (per (a) following): (Cont'd)

- § BellSouth SWA Transport
- § BellSouth SWA Managed Shared Network Service
- § BellSouth Dedicated Ring
- § BellSouth SWA DS0 Service
- § BellSouth SWA DS1 Service
- § BellSouth SWA DS3 Service
- § BellSouth Directory Transport
- § Federal Government Transport Plan

(a) The following percentages of total monthly recurring billing for eligible BellSouth Transport Services (as set forth previously herein 2.4.8(F)(3)) will count as qualifying revenue:

- 10% when a customer signs a Plan A term.
- 25% when a customer signs a Plan B term.
- 35% when a customer signs a Plan C or Plan D term.

Additionally, a customer must maintain at least 75% of its existing Fast Packet Services monthly recurring billing during the FSP interim period (as set forth in 2.4.8(F)(10) following) to allow eligible BellSouth Transport Services to count as qualifying revenue.

(4) The lengths of the term plans available for a BellSouth FSP agreement are as follows:

- Plan A (36 to 59 Months)
- Plan B (60 to 83 Months)
- Plan C (84 to 143 Months)
- Plan D (144 Months)¹

⁽¹⁾ The Plan D term is only available with a \$2,000,000 Minimum Monthly Revenue Commitment level.

⁽²⁾ Exchange Access Frame Relay Service (a.k.a. BellSouth Exchange Access Frame Relay Service), BellSouth Exchange Access Asynchronous Transfer Mode Service, BellSouth Managed Shared Frame Relay Service, and BellSouth Managed Shared Asynchronous Transfer Mode Service have been discontinued and are no longer available in this publication (see WC Dkt. 11-120).

(Z)

ISSUED: DECEMBER 23, 2022

EFFECTIVE: JANUARY 1, 2023

ACCESS SERVICE

2 - General Regulations (Cont'd)

2.4 Payment Arrangements and Credit Allowances (Cont'd)

2.4.8 Optional Payment Plans (Cont'd)

(F) BellSouth Fast Packet Savings Plan⁽²⁾ (Cont'd)

(5) The following table provides the minimum monthly revenue commitment levels for a customer's qualifying revenues under a BellSouth FSP agreement¹. The customer specifies their minimum monthly revenue commitment level (hereinafter referred to as monthly revenue commitment or revenue commitment) and the term plan for their BellSouth FSP agreement. Based upon these two parameters, a specific schedule of credits applies during their BellSouth FSP agreement. Each credit schedule contains the credit percentages applicable to the month-to-month rates and nonrecurring charges for eligible Fast Packet Services defined in 2.4.8(F)(1). The credit schedules are identified by: an alpha character that identifies the term plan, and a numeric character that identifies the customer's minimum monthly revenue commitment level. Credit schedules are provided following in 2.4.8(F)(6).

Minimum Monthly Revenue Commitment Level	Credit Schedule			
	Plan A Term 36 - 59 Months	Plan B Term 60 - 83 Months	Plan C Term 84 - 143 Months	Plan D Term 144 Months
\$ 750,000	Schedule 0A	Schedule 0B	Schedule 0C	-
\$ 2,000,000	Schedule 1A	Schedule 1B	Schedule 1C	Schedule 1D
\$ 5,000,000	Schedule 2A	Schedule 2B	Schedule 2C	-
\$ 10,000,000	Schedule 3A	Schedule 3B	Schedule 3C	-

Note 1: Only monthly recurring billing for qualifying services is used in determining a customer's monthly revenue which applies towards their minimum monthly revenue commitment; nonrecurring billing for qualifying services does not apply.

Note 2: Exchange Access Frame Relay Service (a.k.a. BellSouth Exchange Access Frame Relay Service), BellSouth Exchange Access Asynchronous Transfer Mode Service, BellSouth Managed Shared Frame Relay Service, and BellSouth Managed Shared Asynchronous Transfer Mode Service have been discontinued and are no longer available in this publication (see WC Dkt. 11-120). (Z)

ISSUED: DECEMBER 23, 2022

EFFECTIVE: JANUARY 1, 2023

ACCESS SERVICE

2 - General Regulations (Cont'd)

2.4 Payment Arrangements and Credit Allowances (Cont'd)

2.4.8 Optional Payment Plans (Cont'd)

(F) BellSouth Fast Packet Savings Plan⁽¹⁾ (Cont'd)

(6) The credit schedules for BellSouth Fast Packet Savings Plan agreements are as follows. Within each credit schedule a unique credit applies based upon the transmission speed of the eligible service (and as stated for features).

(a) The following credit schedules are applicable for Fast Packet Access Services. A unique credit applies based upon the transmission speed of the eligible Fast Packet Service. A separate credit applies for Fast Packet Access Services' features; the Features credit is also applicable for BellSouth CNM-NVS.

Credit Schedule	Credit Percentages							
	56/64 Kbps	112-1152 Kbps	1.536 Mbps	Multilink, Subrate T3 & IMA	44.210 Mbps	149.760 Mbps	599.040 Mbps	Features
0A	7%	8%	6%	5%	5%	3%	5%	6%
0B	9%	10%	8%	7%	7%	5%	7%	8%
0C	23%	12%	18%	15%	15%	18%	18%	9%
1A	13%	14%	11%	10%	10%	6%	10%	11%
1B	18%	16%	16%	14%	14%	9%	14%	16%
1C	45%	18%	35%	29%	29%	35%	35%	17%
1D	50%	21%	39%	35%	35%	40%	40%	31%
2A	34%	20%	29%	26%	26%	16%	26%	29%
2B	48%	22%	41%	37%	37%	22%	37%	41%
2C	54%	33%	50%	45%	45%	45%	45%	45%
3A	40%	22%	35%	30%	30%	19%	31%	30%
3B	54%	33%	50%	45%	45%	45%	45%	45%
3C	56%	38%	54%	50%	50%	50%	50%	50%

⁽¹⁾ Exchange Access Frame Relay Service (a.k.a. BellSouth Exchange Access Frame Relay Service), BellSouth Exchange Access Asynchronous Transfer Mode Service, BellSouth Managed Shared Frame Relay Service, and BellSouth Managed Shared Asynchronous Transfer Mode Service have been discontinued and are no longer available in this publication (see WC Dkt. 11-120). (Z)

ISSUED: DECEMBER 23, 2022

EFFECTIVE: JANUARY 1, 2023

ACCESS SERVICE

2 - General Regulations (Cont'd)

2.4 Payment Arrangements and Credit Allowances (Cont'd)

2.4.8 Optional Payment Plans (Cont'd)

(F) BellSouth Fast Packet Savings Plan⁽²⁾ (Cont'd)

(6) (Cont'd)

(b) The credit schedules for LightGate service (a.k.a. BellSouth SPA Point to Point) are as follows:

Credit Schedule	Credit Percentages		
	ME 2-99 Mbps and ME Independent Company Trunk	ME 100 - 499 Mbps	ME 500 Mbps - 1 Gbps
	(1)		
0A	25%	25%	25%
0B	29%	29%	29%
0C	35%	35%	35%
1A	28%	28%	28%
1B	32%	32%	32%
1C	38%	38%	38%
1D	40%	40%	40%
2A	30%	30%	30%
2B	34%	34%	34%
2C	40%	40%	40%
3A	32%	32%	32%
3B	36%	36%	36%
3C	50%	50%	50%

(1) These FSP discounts are also applicable to features that are not related to transmission speed.
 (2) Exchange Access Frame Relay Service (a.k.a. BellSouth Exchange Access Frame Relay Service), BellSouth Exchange Access Asynchronous Transfer Mode Service, BellSouth Managed Shared Frame Relay Service, and BellSouth Managed Shared Asynchronous Transfer Mode Service have been discontinued and are no longer available in this publication (see WC Dkt. 11-120).

(Z)

ISSUED: DECEMBER 23, 2022

EFFECTIVE: JANUARY 1, 2023

ACCESS SERVICE
 2 - General Regulations (Cont'd)

2.4 Payment Arrangements and Credit Allowances (Cont'd)

2.4.8 Optional Payment Plans (Cont'd)

(F) BellSouth Fast Packet Savings Plan⁽¹⁾ (Cont'd)

- (7) Each month under a BellSouth FSP agreement the customer's eligible billing will be adjusted via a credit. The monthly credit will be equal to the previous month's eligible revenue times the appropriate credit percentage set forth in the credit schedule specified by the customer's BellSouth FSP agreement.
- (8) To subscribe to a BellSouth FSP, a customer must submit to the Telephone Company a signed agreement provided by the Telephone Company specifying the customer's monthly revenue commitment and the term plan (indicating the actual number of plan months) desired for their FSP agreement. The customer must also identify to the Telephone Company all Access Customer Name Abbreviations (ACNAs) to be included in the BellSouth FSP agreement. The BellSouth FSP effective service date will be negotiated by the Telephone Company and the customer. The negotiated effective service date shall be no later than 30 days after the Telephone Company has received the aforementioned signed agreement from the customer with the required information to develop the FSP agreement. BellSouth FSP credits specified in 2.4.8(F)(7) will begin with the first bill period following the negotiated effective service date of the BellSouth FSP agreement.
- (9) Except as specified in (9)(a) following, to enroll in a BellSouth FSP agreement, the customer's monthly qualifying revenues at the time of enrollment (based upon the most current monthly billing data available) must equal or exceed the entry level minimum qualifying revenue specified in the table following. The entry level minimum qualifying revenue depends upon the term plan and monthly revenue commitment level selected for the customer's FSP agreement. The entry level minimum qualifying revenues are as follows:

Minimum Monthly Revenue Commitment Level	Entry Level Minimum Qualifying Revenues			
	Plan A Term	Plan B Term	Plan C Term	Plan D Term
	36 - 59 Months (50% of MMRC)	60 - 83 Months (35% of MMRC)	84 - 143 Months (20% of MMRC)	144 Months (5% of MMRC)
\$ 750,000	\$ 375,000	\$ 262,500	\$ 150,000	-
\$ 2,000,000	\$ 1,000,000	\$ 700,000	\$ 400,000	\$100,000
\$ 5,000,000	\$ 2,500,000	\$ 1,750,000	\$ 1,000,000	-
\$ 10,000,000	\$ 5,000,000	\$ 3,500,000	\$ 2,000,000	-

- (a) A customer may enroll in a BellSouth FSP agreement between November 14, 2001, and February 14, 2002, with only 50% of the entry level minimum qualifying revenues set forth above.

⁽¹⁾ Exchange Access Frame Relay Service (a.k.a. BellSouth Exchange Access Frame Relay Service), BellSouth Exchange Access Asynchronous Transfer Mode Service, BellSouth Managed Shared Frame Relay Service, and BellSouth Managed Shared Asynchronous Transfer Mode Service have been discontinued and are no longer available in this publication (see WC Dkt. 11-120). (Z)

ISSUED: DECEMBER 23, 2022

EFFECTIVE: JANUARY 1, 2023

ACCESS SERVICE

2 - General Regulations (Cont'd)

2.4 Payment Arrangements and Credit Allowances (Cont'd)

2.4.8 Optional Payment Plans (Cont'd)

(F) BellSouth Fast Packet Savings Plan⁽¹⁾ (Cont'd)

(10) Subject to meeting the requirements set forth in 2.4.8(F)(9), customers are allowed an interim period beginning with the establishment of their BellSouth FSP agreement to increase their qualifying monthly revenues to the level of the monthly revenue commitment specified in their FSP agreement. The length of this interim period differs based upon the term plan selected for the customer's FSP agreement as follows:

- Plan A 12 month interim period allowed
- Plan B 24 month interim period allowed
- Plan C 36 month interim period allowed
- Plan D 60 month interim period allowed

(11) Once the interim period specified in 2.4.8(F)(10) preceding has been completed, a Shortfall Charge shall apply on a going forward basis for each month that the customer's qualifying revenue does not equal or exceed the customer's revenue commitment. The applicable Shortfall Charge for each such month is an amount equal to the difference between the customer's monthly revenue commitment and their actual qualifying revenues billed that month.

(12) Subject to the terms set forth in 2.4.8(F)(8) for initiating a new FSP agreement, customers may request to revise an existing FSP agreement to include a different length of term and/or monthly revenue commitment. The number of months served under the existing FSP agreement will be counted in establishing the total term length for the revised FSP agreement (i.e., providing recognition of previous FSP service). Based upon customer requested revisions in the total length of the FSP agreement and/or monthly revenue commitment, the customer's credit schedule as specified in 2.4.8(F)(6) may change.

A customer may make such revisions to his FSP agreement without a Commitment Reduction Charge (discussed following) as long as the total revenue commitment associated with the revised FSP agreement is equal to or greater than the total revenue commitment for the existing FSP agreement.

The total revenue commitment associated with the existing plan is the product of multiplying the total number of months specified in the customer's existing FSP agreement by the existing plan's monthly revenue commitment.

The total revenue commitment associated with the revised plan is determined by taking the product of multiplying the number of months served under the existing plan by the existing plan's monthly revenue commitment, and adding it to, the product of multiplying the number of additional months in the revised FSP plan by the revised plan's monthly revenue commitment.

⁽¹⁾ Exchange Access Frame Relay Service (a.k.a. BellSouth Exchange Access Frame Relay Service), BellSouth Exchange Access Asynchronous Transfer Mode Service, BellSouth Managed Shared Frame Relay Service, and BellSouth Managed Shared Asynchronous Transfer Mode Service have been discontinued and are no longer available in this publication (see WC Dkt. 11-120). (Z)

ISSUED: DECEMBER 23, 2022

EFFECTIVE: JANUARY 1, 2023

ACCESS SERVICE

2 - General Regulations (Cont'd)

2.4 Payment Arrangements and Credit Allowances (Cont'd)

2.4.8 Optional Payment Plans (Cont'd)

(F) BellSouth Fast Packet Savings Plan⁽¹⁾ (Cont'd)

(12) (Cont'd)

If the total revenue commitment associated with the revised FSP plan is less than the total revenue commitment associated with the existing plan, a Commitment Reduction Charge is applicable. This Commitment Reduction Charge is equal to the product of the total FSP credits received by the customer since the initiation of a FSP plan, multiplied by, 1 minus the ratio of the revised plan total revenue commitment to the existing plan total revenue commitment.

For example: After 40 months, a customer with a 60 month FSP agreement with a \$5,000,000 revenue commitment per month (discount schedule 2B) wants to change to a \$2,000,000 revenue commitment for the next 36 months. (The customer's new agreement will be for a total of 76 months (40 months plus 36 months). FSP crediting for the next 36 months will be under discount schedule 1B.) Thus far under the existing FSP agreement, the customer has produced over \$200,000,000 in qualifying revenues, which included \$100,000,000 of eligible service revenues upon which he has received a total of \$40,000,000 in FSP credits.

The total revenue commitment associated with the existing plan is calculated as follows:

$$60 \text{ months times } \$5,000,000 = \$300,000,000.$$

The total revenue commitment associated with the revised (76 month) plan is calculated as follows:

$$\begin{aligned} &= (40 \text{ months times } \$5,000,000) \text{ plus } (36 \text{ months times } \$2,000,000) \\ &= (\$200,000,000) \text{ plus } (\$72,000,000) \\ &= \$272,000,000 \end{aligned}$$

A Commitment Reduction Charge (CRC) applies since the revised plan's total revenue commitment is less than the existing plan's total revenue commitment. The charge is calculated as follows:

$$\begin{aligned} \text{CRC} &= \$40,000,000 \times (1 - (\$272,000,000/\$300,000,000)) \\ &= \$40,000,000 \times (1 - .9067) \\ &= \$40,000,000 \times (.0933) \\ &= \$ 3,732,000 \end{aligned}$$

⁽¹⁾ Exchange Access Frame Relay Service (a.k.a. BellSouth Exchange Access Frame Relay Service), BellSouth Exchange Access Asynchronous Transfer Mode Service, BellSouth Managed Shared Frame Relay Service, and BellSouth Managed Shared Asynchronous Transfer Mode Service have been discontinued and are no longer available in this publication (see WC Dkt. 11-120). (Z)

ISSUED: DECEMBER 23, 2022

EFFECTIVE: JANUARY 1, 2023

ACCESS SERVICE

2 - General Regulations (Cont'd)

2.4 Payment Arrangements and Credit Allowances (Cont'd)

2.4.8 Optional Payment Plans (Cont'd)

(F) BellSouth Fast Packet Savings Plan⁽¹⁾ (Cont'd)

(12) (Cont'd)

- (a) Under the terms set forth herein, a customer may extend the period of time under their FSP agreement. If the increase in total number of months causes the revised FSP agreement to fall under a longer term plan (as set forth in 2.4.8(F)(4)) than the existing agreement, the customer qualifies for a longer interim period (discussed in 2.4. (F)(10)).

The additional interim period time allowed is equal to the difference between the interim period months associated with the revised agreement's term plan, less the interim period months associated with the existing plan which have not passed. The total interim period months allowed such a customer shall not exceed the number of interim period months specified in 2.4.8. (F)(10) preceding based upon the revised agreement's term plan. Any additional interim period time appropriate for a customer shall begin with the start date of the revised agreement.

- (b) Under the terms set forth herein, a customer may decrease the period of time under their FSP agreement. If the decrease in total number of months causes the revised FSP agreement to fall under a shorter term plan (as set forth in 2.4.8(F)(4)) than the existing agreement, the customer no longer qualifies for the longer interim period (discussed in 2.4.8(F)(10)) associated with the existing plan. The following terms apply upon the effective date of the revised agreement:

- If the interim period associated with the existing FSP agreement has passed, no action is taken.
- If the interim period associated with the existing FSP agreement is underway and has progressed beyond the interim period associated with the revised FSP agreement (as specified in 2.4.8(F)(10)), the customer's interim period shall cease upon the effective date of the revised agreement.
- If the interim period associated with the existing FSP agreement is underway and has not progressed beyond the interim period associated with the revised FSP agreement, the total interim period allowed the customer is the number of months for the revised FSP agreement's term plan (as set forth in 2.4.8(F)(10)).

⁽¹⁾ Exchange Access Frame Relay Service (a.k.a. BellSouth Exchange Access Frame Relay Service), BellSouth Exchange Access Asynchronous Transfer Mode Service, BellSouth Managed Shared Frame Relay Service, and BellSouth Managed Shared Asynchronous Transfer Mode Service have been discontinued and are no longer available in this publication (see WC Dkt. 11-120).

(Z)

ISSUED: DECEMBER 23, 2022

EFFECTIVE: JANUARY 1, 2023

ACCESS SERVICE

2 - General Regulations (Cont'd)

2.4 Payment Arrangements and Credit Allowances (Cont'd)

2.4.8 Optional Payment Plans (Cont'd)

(F) BellSouth Fast Packet Savings Plan⁽¹⁾ (Cont'd)

(12) (Cont'd)

- (c) Under the terms set forth herein, a customer may increase their monthly revenue commitment and extend the period of time under their FSP agreement. If the increase in total number of months causes the revised FSP agreement to fall under a longer term plan (as set forth in 2.4.8(F)(4)) than the existing agreement, the customer qualifies for a longer interim period (discussed in 2.4.(F)(10)).

The additional interim period time allowed is equal to the difference between the interim period months associated with the revised agreement's term plan, less the interim period months associated with the existing plan which have not passed, plus 12 months. Any additional interim period time appropriate for a customer shall begin with the start date of the revised agreement.

- (d) Under the terms set forth herein, a customer may increase their monthly revenue commitment and continue with the period of time under their FSP agreement. A customer qualifies for an additional 12 months to be added to the existing interim period.
- (e) Under the terms set forth herein, a customer may increase their monthly revenue commitment and shorten the period of time under their FSP agreement. The following terms apply:
- If the decrease in total number of months causes the revised FSP agreement total revenue commitment to be less than the total revenue commitment associated with the existing plan, then a Commitment Reduction Charge will apply. No time period extension to the interim period will be provided.
 - If the revised FSP agreement total revenue commitment is greater than the existing plan total revenue commitment, a customer will receive an additional 12 months to be added to the existing interim period.

⁽¹⁾ Exchange Access Frame Relay Service (a.k.a. BellSouth Exchange Access Frame Relay Service), BellSouth Exchange Access Asynchronous Transfer Mode Service, BellSouth Managed Shared Frame Relay Service, and BellSouth Managed Shared Asynchronous Transfer Mode Service have been discontinued and are no longer available in this publication (see WC Dkt. 11-120).

(Z)

ISSUED: DECEMBER 23, 2022

EFFECTIVE: JANUARY 1, 2023

ACCESS SERVICE

2 - General Regulations (Cont'd)

2.4 Payment Arrangements and Credit Allowances (Cont'd)

2.4.8 Optional Payment Plans (Cont'd)

(F) BellSouth Fast Packet Savings Plan⁽¹⁾ (Cont'd)

(13) No Termination Liability Charge will apply.

(14) In the event of a merger or acquisition and both companies have existing BellSouth FSPs, then the customer will have the option of continuing both plans or merging both into one FSP agreement.

If the customer chooses to merge both plans into one FSP agreement, then the plan of the company making the acquisition will remain in effect and the revenues of the acquired company will be combined with those of the company making the acquisition. A revised BellSouth FSP agreement will be established based on these combined revenues subject to the regulations set forth in 2.4.8(F)(12).

If the company resulting from the merger or acquisition chooses not to continue the FSP plan(s), early termination provisions set forth in 2.4.8(F)(13) preceding apply.

(15) In the event of a merger or acquisition if only one company has a BellSouth FSP, then the customer will have the option of continuing the existing FSP plan as is or adding the new company to that existing FSP agreement.

⁽¹⁾ Exchange Access Frame Relay Service (a.k.a. BellSouth Exchange Access Frame Relay Service), BellSouth Exchange Access Asynchronous Transfer Mode Service, BellSouth Managed Shared Frame Relay Service, and BellSouth Managed Shared Asynchronous Transfer Mode Service have been discontinued and are no longer available in this publication (see WC Dkt. 11-120). (Z)

ISSUED: DECEMBER 23, 2022

EFFECTIVE: JANUARY 1, 2023

ACCESS SERVICE

2 - General Regulations (Cont'd)

2.4 Payment Arrangements and Credit Allowances (Cont'd)

2.4.8 Optional Payment Plans (Cont'd)

(F) BellSouth Fast Packet Savings Plan⁽¹⁾ (Cont'd)

(15) (Cont'd)

If the customer chooses to add the new company to the existing FSP agreement, then the existing plan will remain in effect and the revenues of the company will be combined with those of the existing company. A revised BellSouth FSP agreement will be established based on these combined revenues subject to the regulations set forth in 2.4.8(F)(12) preceding.

If the company resulting from the merger or acquisition chooses not to continue the FSP plan, early termination provisions set forth in 2.4.8(F)(13) preceding apply.

⁽¹⁾ Exchange Access Frame Relay Service (a.k.a. BellSouth Exchange Access Frame Relay Service), BellSouth Exchange Access Asynchronous Transfer Mode Service, BellSouth Managed Shared Frame Relay Service, and BellSouth Managed Shared Asynchronous Transfer Mode Service have been discontinued and are no longer available in this publication (see WC Dkt. 11-120).

(Z)

ISSUED: DECEMBER 23, 2022

EFFECTIVE: JANUARY 1, 2023

ACCESS SERVICE

2 - General Regulations (Cont'd)

2.4 Payment Arrangements and Credit Allowances (Cont'd)

2.4.8 Optional Payment Plans (Cont'd)

(F) BellSouth Fast Packet Savings Plan⁽¹⁾ (Cont'd)

(16) During a promotional period from April 30, 2004 to July 29, 2004, customers subscribing to a new BellSouth FSP agreement and customers upgrading an existing BellSouth FSP agreement will additionally qualify to receive a FSP Network to Network Interface (NNI) Promotion monthly reward credit. This reward credit will apply when the customer has placed at least one of the Fast Packet Access Services specified in (a) following in a minimum of 13 different BellSouth LATAs.

A unique FSP NNI Promotion monthly reward credit is appropriate for each BellSouth FSP Minimum Monthly Revenue Commitment level based upon whether the customer has in place at least one Fast Packet Access Service specified in (a) following in either 13 different BellSouth LATAs, 26 different BellSouth LATAs or 38 different BellSouth LATAs. These reward credits are shown in (b) following. One such reward credit appropriate per FSP customer shall be applied per month once the customer has fulfilled the promotion requirements (beginning with billing periods after May 25, 2004). The appropriate reward credit shall then be applied to the bill each month for the duration of the customer's BellSouth FSP agreement, except that reward crediting shall cease and no longer be applicable for the remainder of the FSP agreement period once the customer falls below the minimum of one Fast Packet Access Service specified in (a) following in at least 13 different BellSouth LATAs.

(a) A minimum of one of the following Fast Packet Access Services at 1.536 Mbps or greater speed with a network interface configured for network to network interface capability (i.e., Frame Relay NNI) must be in place in a minimum of 13 different BellSouth LATAs in order for a customer with a BellSouth FSP agreement subscribed to during this promotional period to begin to receive a FSP NNI Promotion monthly reward credit: BellSouth Exchange Access Frame Relay Service (XAFRS), BellSouth Managed Shared Frame Relay Service (MSFRS).

(b) Monthly reward credit amounts for the FSP NNI Promotion are provided in the schedule following:

FSP Monthly Monthly Revenue Commitment Level	FSP NNI Promotion Monthly Reward Credit		
	NNIs in 13 LATAs	NNIs in 26 LATAs	NNIs in 38 LATAs
	\$ 750,000	\$ 1,070.00	\$ 4,200.00
\$ 2,000,000	\$ 1,270.00	\$ 5,000.00	\$ 11,000.00
\$ 5,000,000	\$ 1,460.00	\$ 5,740.00	\$ 12,710.00
\$ 10,000,000	\$ 1,700.00	\$ 6,690.00	\$ 14,840.00

⁽¹⁾ Exchange Access Frame Relay Service (a.k.a. BellSouth Exchange Access Frame Relay Service), BellSouth Exchange Access Asynchronous Transfer Mode Service, BellSouth Managed Shared Frame Relay Service, and BellSouth Managed Shared Asynchronous Transfer Mode Service have been discontinued and are no longer available in this publication (see WC Dkt. 11-120). (Z)

ISSUED: DECEMBER 23, 2022

EFFECTIVE: JANUARY 1, 2023

ACCESS SERVICE

2 - General Regulations (Cont'd)

2.4 Payment Arrangements and Credit Allowances (Cont'd)

2.4.8 Optional Payment Plans (Cont'd)

(F) BellSouth Fast Packet Savings Plan⁽¹⁾ (Cont'd)

(16)(Cont'd)

(c) Applicable taxes and fees will be based on the standard BellSouth Fast Packet Savings Plan price of qualifying services, and no taxes or fees will be added to the FSP NNI Promotion monthly reward credit applied to customer bills.

(17) During a promotional period from April 1, 2005 to April 30, 2005, new BellSouth FSP Agreements signed with a Minimum Monthly Revenue Commitment of \$5,000,000 with a 60 to 83 month term (referred to as a Plan 2B) shall be provided with promotional terms and conditions stipulated herein for the duration of these FSP Agreements. During the 36th month of such FSP Agreements, the customer must inform the Telephone Company which of the following options they have selected for their FSP Agreement for service beyond the 36th month:

(a) No Termination Liability Charge will apply.

(b) The existing FSP Agreement may be retained for the duration of the selected payment period (of 60 to 83 months) and standard FSP tariff terms and conditions shall apply for the remaining months of the selected term (including Termination Liability for a total termination).

(c) The existing FSP Agreement may be revised to another FSP Agreement subject to the standard terms and conditions outlined within this BellSouth Fast Packet Savings Plan tariff for such changes.

It is the responsibility of the customer to provide to the Telephone Company their choice of the above options prior to the completion of the 36th month of the promotional FSP Agreement. Failure of the customer to provide such direction shall result in (b) above being the default option for the customer and the FSP Agreement shall continue in effect for the remaining duration of the 60 to 83 month term subject to the standard terms and conditions of the FSP tariff.

⁽¹⁾ Exchange Access Frame Relay Service (a.k.a. BellSouth Exchange Access Frame Relay Service), BellSouth Exchange Access Asynchronous Transfer Mode Service, BellSouth Managed Shared Frame Relay Service, and BellSouth Managed Shared Asynchronous Transfer Mode Service have been discontinued and are no longer available in this publication (see WC Dkt. 11-120).

(Z)

ISSUED: JUNE 30, 2020

EFFECTIVE: JULY 15, 2020

ACCESS SERVICE

2 - General Regulations (Cont'd)

2.4 Payment Arrangements and Credit Allowances (Cont'd)

2.4.8 Optional Payment Plans (Cont'd)

(G) Intentionally left blank.

(T)

ISSUED: JUNE 30, 2020

EFFECTIVE: JULY 15, 2020

ACCESS SERVICE

2 - General Regulations (Cont'd)

2.4 Payment Arrangements and Credit Allowances (Cont'd)

2.4.8 Optional Payment Plans (Cont'd)

(G) Intentionally left blank.

(T)

ISSUED: JUNE 30, 2020

EFFECTIVE: JULY 15, 2020

ACCESS SERVICE

2 - General Regulations (Cont'd)

2.4 Payment Arrangements and Credit Allowances (Cont'd)

2.4.8 Optional Payment Plans (Cont'd)

(G) Intentionally left blank.

(T)

BELLSOUTH TELECOMMUNICATIONS
Four AT&T Plaza, Dallas, Texas 75202

TARIFF F.C.C. NO. 1
4TH REVISED PAGE 2-139
CANCELS 3RD REVISED PAGE 2-139

ISSUED: JUNE 30, 2020

EFFECTIVE: JULY 15, 2020

ACCESS SERVICE

2 - General Regulations (Cont'd)

2.4 Payment Arrangements and Credit Allowances (Cont'd)

2.4.8 Optional Payment Plans (Cont'd)

(G) Intentionally left blank.

(T)

ISSUED: JUNE 30, 2020

EFFECTIVE: JULY 15, 2020

ACCESS SERVICE

2 - General Regulations (Cont'd)

2.4 Payment Arrangements and Credit Allowances (Cont'd)

2.4.8 Optional Payment Plans (Cont'd)

(G) Intentionally left blank.

(T)

ISSUED: JUNE 30, 2020

EFFECTIVE: JULY 15, 2020

ACCESS SERVICE

2 - General Regulations (Cont'd)

2.4 Payment Arrangements and Credit Allowances (Cont'd)

2.4.8 Optional Payment Plans (Cont'd)

(G) Intentionally left blank.

(T)

ISSUED: JUNE 30, 2020

EFFECTIVE: JULY 15, 2020

ACCESS SERVICE

2 - General Regulations (Cont'd)

2.4 Payment Arrangements and Credit Allowances (Cont'd)

2.4.8 Optional Payment Plans (Cont'd)

(G) Intentionally left blank.

(T)

ISSUED: JUNE 30, 2020

EFFECTIVE: JULY 15, 2020

ACCESS SERVICE

2 - General Regulations (Cont'd)

2.4 Payment Arrangements and Credit Allowances (Cont'd)

2.4.8 Optional Payment Plans (Cont'd)

(G) Intentionally left blank.

(T)

ISSUED: JUNE 30, 2020

EFFECTIVE: JULY 15, 2020

ACCESS SERVICE

2 - General Regulations (Cont'd)

2.4 Payment Arrangements and Credit Allowances (Cont'd)

2.4.8 Optional Payment Plans (Cont'd)

(G) Intentionally left blank.

(T)

ISSUED: JUNE 30, 2020

EFFECTIVE: JULY 15, 2020

ACCESS SERVICE

2 - General Regulations (Cont'd)

2.4 Payment Arrangements and Credit Allowances (Cont'd)

2.4.8 Optional Payment Plans (Cont'd)

(G) Intentionally left blank.

(T)

ISSUED: JUNE 30, 2020

EFFECTIVE: JULY 15, 2020

ACCESS SERVICE

2 - General Regulations (Cont'd)

2.4 Payment Arrangements and Credit Allowances (Cont'd)

2.4.8 Optional Payment Plans (Cont'd)

(G) Intentionally left blank.

(T)

ISSUED: JUNE 30, 2020

EFFECTIVE: JULY 15, 2020

ACCESS SERVICE

2 - General Regulations (Cont'd)

2.4 Payment Arrangements and Credit Allowances (Cont'd)

2.4.8 Optional Payment Plans (Cont'd)

(G) Intentionally left blank.

(T)

ISSUED: JUNE 30, 2020

EFFECTIVE: JULY 15, 2020

ACCESS SERVICE

2 - General Regulations (Cont'd)

2.4 Payment Arrangements and Credit Allowances (Cont'd)

2.4.8 Optional Payment Plans (Cont'd)

(G) Intentionally left blank.

(T)

ISSUED: JUNE 30, 2020

EFFECTIVE: JULY 15, 2020

ACCESS SERVICE

2 - General Regulations (Cont'd)

2.4 Payment Arrangements and Credit Allowances (Cont'd)

2.4.8 Optional Payment Plans (Cont'd)

(G) Intentionally left blank.

(T)

ISSUED: JUNE 30, 2020

EFFECTIVE: JULY 15, 2020

ACCESS SERVICE

2 - General Regulations (Cont'd)

2.4 Payment Arrangements and Credit Allowances (Cont'd)

2.4.8 Optional Payment Plans (Cont'd)

(G) Intentionally left blank.

(T)

ISSUED: JUNE 30, 2020

EFFECTIVE: JULY 15, 2020

ACCESS SERVICE

2 - General Regulations (Cont'd)

2.4 Payment Arrangements and Credit Allowances (Cont'd)

2.4.8 Optional Payment Plans (Cont'd)

(H) Intentionally left blank.

(T)

BELLSOUTH TELECOMMUNICATIONS
Four AT&T Plaza, Dallas, Texas 75202

TARIFF F.C.C. NO. 1
3RD REVISED PAGE 2-152
CANCELS 2ND REVISED PAGE 2-152

ISSUED: JUNE 30, 2020

EFFECTIVE: JULY 15, 2020

ACCESS SERVICE

2 - General Regulations (Cont'd)

2.4 Payment Arrangements and Credit Allowances (Cont'd)

2.4.8 Optional Payment Plans (Cont'd)

(H) Intentionally left blank.

(T)

ISSUED: JUNE 30, 2020

EFFECTIVE: JULY 15, 2020

ACCESS SERVICE

2 - General Regulations (Cont'd)

2.4 Payment Arrangements and Credit Allowances (Cont'd)

2.4.8 Optional Payment Plans (Cont'd)

(H) Intentionally left blank.

(T)

BELLSOUTH TELECOMMUNICATIONS
Four AT&T Plaza, Dallas, Texas 75202

TARIFF F.C.C. NO. 1
2ND REVISED PAGE 2-154
CANCELS 1ST REVISED PAGE 2-154

ISSUED: JUNE 30, 2020

EFFECTIVE: JULY 15, 2020

ACCESS SERVICE

2 - General Regulations (Cont'd)

2.4 Payment Arrangements and Credit Allowances (Cont'd)

2.4.8 Optional Payment Plans (Cont'd)

(H) Intentionally left blank.

(T)

BELLSOUTH TELECOMMUNICATIONS
Four AT&T Plaza, Dallas, Texas 75202

TARIFF F.C.C. NO. 1
2ND REVISED PAGE 2-155
CANCELS 1ST REVISED PAGE 2-155

ISSUED: JUNE 30, 2020

EFFECTIVE: JULY 15, 2020

ACCESS SERVICE

2 - General Regulations (Cont'd)

2.4 Payment Arrangements and Credit Allowances (Cont'd)

2.4.8 Optional Payment Plans (Cont'd)

(H) Intentionally left blank.

(T)

ISSUED: JUNE 30, 2020

EFFECTIVE: JULY 15, 2020

ACCESS SERVICE

2 - General Regulations (Cont'd)

2.4 Payment Arrangements and Credit Allowances (Cont'd)

2.4.9 Service Installation Guarantee

- (A) The Telephone Company assures that orders for services to which the Service Installation Guarantee applies will be installed and available for customer use no later than the Service Date as specified in Section 5.1.1. The Service Installation Guarantee is applicable only as specified in Sections 2.4.9, 6.7.1(D) and 7.4.1(C) of this Tariff and for the Cross Connect elements in Section 13 of this Tariff.
- (B) The failure of the Telephone Company to meet this commitment will result in a Service Installation Guarantee credit being applied to the Customer's bill. The Service Installation Guarantee credit will only apply to the services specified in Section 6.7.1.(D), Section 7.4.1.(C), the Connection rate element specified in Section 28.1.9(A), and Cross Connect elements in Sections 13.3.22, 13.3.23, and 13.3.24 of this tariff, for which nonrecurring charges are applicable. The Service Installation Guarantee credit will be determined as follows:
1. For DS1 Special Access (a.k.a. BellSouth SPA DS1) and BellSouth SPA DS1 Diverse services, the Service Installation Guarantee credit will equal \$350 per DS1 circuit experiencing the missed Service Date or the amount of the actual installation charge, whichever is less.
 2. For all other eligible services, the Service Installation Guarantee credit will be equal to the billed nonrecurring charges associated with the individual service having the missed Service Date.

The Service Installation Guarantee credit will not be provided if the installation charge has been waived or credited for some other reason.

- (C) For BellSouth Dedicated Ring, the Service Installation Guarantee is applicable for all channel interface rate elements. BellSouth Dedicated Ring ⁽¹⁾ ring level rate elements are excluded from the Service Installation Guarantee. BellSouth Dedicated Ring level rate elements are defined as follows: Local Channel, Interoffice Channel, Internodal Channel, Alternate Central Office Channel, Customer Node and Central Office Node.
- (D) The Service Installation Guarantee is applicable to DS1 Diverse service Local and Interoffice Channel rate elements for which nonrecurring charges are appropriate.

ISSUED: DECEMBER 23, 2022

EFFECTIVE: JANUARY 1, 2023

ACCESS SERVICE

2 - General Regulations (Cont'd)

2.4 Payment Arrangements and Credit Allowances (Cont'd)

2.4.9 Installation Guarantee (Cont'd) Service

(E) The Service Installation Guarantee applies for the following Fast Packet Access Services⁽¹⁾ at DSO and DS1 levels only: BellSouth Exchange Access Frame Relay Service and Managed Shared Frame Relay Service.

(F) Service Installation Guarantees do not apply:

- (1) on Switched (a.k.a. BellSouth SWA) and Special Access (a.k.a. BellSouth SPA) services installations, moves and rearrangement of service with an agreed upon service date interval of four business days or less following the Application Date of the service order. The Application Date for Switched (a.k.a. BellSouth SWA) and Special Access (a.k.a. BellSouth SPA) is as specified in Section 5.1.1(G).
- (2) on Special Access (a.k.a. BellSouth SPA) and Fast Packet Access service⁽¹⁾ orders for installations, moves and rearrangement of services with service dates that have been advanced from the standard or negotiated service interval as specified in Section 5.1.1(H), or
- (3) when failure to meet the Service Date occurs because of:
 - (a) any act or omission, which shall include an accurate and complete service order, from this customer, any other customer or any third party, or of any other entity providing a portion of a service,
 - (b) labor difficulties, governmental orders, civil commotions, criminal actions against the Telephone Company, acts of God, war, or other circumstances beyond the Telephone Company's control,
 - (c) unavailability of the customer's facilities and/or equipment,
- (4) to service requiring Special Construction as set forth in BellSouth Telecommunications Tariff F.C.C. No. 2.

⁽¹⁾ Exchange Access Frame Relay Service (a.k.a. BellSouth Exchange Access Frame Relay Service), BellSouth Exchange Access Asynchronous Transfer Mode Service, BellSouth Managed Shared Frame Relay Service, and BellSouth Managed Shared Asynchronous Transfer Mode Service have been discontinued and are no longer available in this publication (see WC Dkt. 11-120).

(Z)

ISSUED: JUNE 30, 2020

EFFECTIVE: JULY 15, 2020

ACCESS SERVICE

2 - General Regulations (Cont'd)

2.4 Payment Arrangements and Credit Allowances (Cont'd)

2.4.9

Service

(F) Service Installation Guarantees do not apply: (Cont'd)

- (5) to Specialized Service or Arrangements or Individual Case Basis filings,
- (6) to BellSouth Virtual Expanded Interconnection service arrangements, as set forth in Section 20 of this Tariff, or
- (7) for jointly provisioned services except as stipulated in 2.4.9(C) preceding.

In addition, Service Installation Guarantees will not apply during a declared National Emergency. Priority installation of National Security Emergency Preparedness (NSEP) telecommunications services shall take precedence.

2.5 Connections

Equipment and Systems (i.e., terminal equipment, multiline terminating systems and communications systems) may be connected with BellSouth SWA and Special Access (a.k.a. BellSouth SPA) service furnished by the Telephone Company where such connection is made in accordance with the provisions specified in Technical Reference Publication AS No. 1 and in 2.1 preceding.

2.6 Definitions

Certain terms used herein are defined as follows:

Access Code

The term "Access Code" denotes a uniform seven digit code assigned by the Telephone Company to an individual customer. The seven digit code has the form 101XXXX and 950-XXXX.

ISSUED: JUNE 30, 2020

EFFECTIVE: JULY 15, 2020

ACCESS SERVICE

2 - General Regulations (Cont'd)

2.6 Definitions (Cont'd)

Additional Residential Local Exchange Service ("Additional Residential Line")

This term denotes any residential local exchange service ("residential line") provided by the Telephone Company or a reseller of a Telephone Company-provided residential line at a residential premises other than the Primary Residential Line, as defined below. The Additional Residential Local Exchange Service Line or Trunk FUS and EUCL charges apply to such residential lines.

Alternate Central Office

The term "Alternate Central Office" denotes a wire center other than the serving wire center of the location of a customer node associated with BellSouth Dedicated Ring.

Answer/Disconnect Supervision

The term "Answer/Disconnect Supervision" denotes the transmission of the switch trunk equipment supervisory signal (off-hook or on-hook) to the customer's point of termination as an indication that the called party has answered or disconnected.

ISSUED: JUNE 30, 2020

EFFECTIVE: JULY 15, 2020

ACCESS SERVICE

2 - General Regulations (Cont'd)

2.6 Definitions (Cont'd)

Attenuation Distortion

The term "Attenuation Distortion" denotes the difference in loss at specified frequencies relative to the loss at 1004 Hz, unless otherwise specified.

Authorized Traceback Group

A designee of the Telephone Company which it authorizes to issue Traceback Requests for traffic received by the Telephone Company. Telephone Company currently designates The USTelecom Industry Traceback Group or any successor organization to be an Authorized Traceback Group.

B8ZS

The Term "B8ZS" (Bipolar with 8 Zero Substitution) denotes a line code which allows transport of an all-zero octet over a High Capacity DS1 (a.k.a. BellSouth SPA DS1) channel. B8ZS enables Clear Channel Capability on a High Capacity DS1 (a.k.a. BellSouth SPA DS1) service.

Balance (100 Type) Test Line

The term "Balance (100 Type) Test Line" denotes an arrangement in an end office which provides for balance and noise testing.

Basic Service Element

The term Basic Service Element denotes an optional network capability associated with a Basic Serving Arrangement.

BellSouth Direct Access to Directory Assistance

The term "BellSouth Direct Access to Directory Assistance" denotes the provision of direct access to BellSouth's Directory Assistance Listing Database, Directory Assistance Search Application and Database Administration Call Control to enable a customer to provide voice Directory Assistance Service to its end users.

BellSouth Direct Access to Directory Assistance Location

The term "BellSouth Direct Access to Directory Assistance Location" denotes the Telephone Company location for the Directory Assistance Listing Database, the DA Search Application, and the Database Administration Call Control. The Company will provide BellSouth Direct Access to Directory Assistance from its location as specified in the NATIONAL EXCHANGE CARRIER ASSOCIATION, INC., TARIFF F.C.C. NO. 4.

ISSUED: AUGUST 29, 2016

EFFECTIVE: SEPTEMBER 13, 2016

ACCESS SERVICE
2 - General Regulations (Cont'd)

2.6 Definitions (Cont'd)

BellSouth Directory Assistance (Interstate)

The term "BellSouth Directory Assistance" denotes the provision of telephone numbers by a Telephone Company operator when the operator location is accessed by a customer premises by sending the appropriate signals, i.e., 411, 555-1212 or (NPA) 555-1212.

BellSouth Directory Assistance Location (Interstate)

The term "BellSouth Directory Assistance Location" denotes a Telephone Company office where Telephone Company equipment first receives the Directory Assistance call from a customer's premises and selects the first operator position to respond to the Directory Assistance call.

(D)

(D)

BellSouth Line Information Data Base Location

The term "BellSouth Line Information Data Base Location" denotes the BellSouth Signaling Transfer Point (STP) that serves the BellSouth Line Information Data Base.

ISSUED: DECEMBER 11, 2014

EFFECTIVE: DECEMBER 26, 2014

ACCESS SERVICE

2 - General Regulations (Cont'd)

2.6 Definitions (Cont'd)

BellSouth Line Information Data Base Access Service

BellSouth Line Information Data Base Access Service will transport queries and responses to and from the customer's Signaling Point of Interconnection (SPOI) and BellSouth's Line Information Data Base Access Service. This service will enable customers to validate billing information stored in BellSouth's Line Information Data Base.

BellSouth Local Number Portability Database Services

The term "BellSouth Local Number Portability Database Services" denotes the query services which provide the routing information to allow wireline and wireless telecommunications carriers or the Telephone Company to direct calls placed to a ported number to the correct switch for completion to the end user.

BellSouth SWA Basic Serving Arrangement

The term "BellSouth SWA Basic Serving Arrangement" denotes the connection of a customer to and through the BOCs networks, and should be considered the fundamental connection to those networks.

BellSouth SWA Common Transport

The term "BellSouth SWA Common Transport" denotes the transmission of the customer's BellSouth SWA traffic between the Access Tandem and the end office, between the BellSouth SWA FGA dial tone office and the end office (for terminating traffic) and, between the end office which serves as the host office for a remote switching system or module (RSS or RSM) and the RSS or RSM.

BellSouth SWA Dedicated Transport

The term "BellSouth SWA Transport" denotes the transmission of the customer's BellSouth SWA traffic utilizing dedicated facilities, when ordered by the customer, between the customer's serving wire center (SWC) and customer designated points, i.e. SWC to a Telephone Company Facility Hub (Hub). SWC to an Access Tandem, SWC to a customer designated end office, Hub to an Access Tandem, Hub to Hub, and Hub to an end office.

BellSouth SWA FGD and BellSouth SWA TSBSA 3 Signaling

The term "BellSouth SWA TSBSA 3 Signaling" denotes the signaling system which is used by end offices, to transmit originating information and address digits to the customer's premises. Features of this system include overlap outpulsing, identification of the type of call, identification of the ten-digit telephone number of the calling party, and acknowledgment wink supervisory signals.

(C)

ISSUED: JUNE 16, 2011

EFFECTIVE: JULY 1, 2011

ACCESS SERVICE

2 - General Regulations (Cont'd)

2.6 Definitions (Cont'd)

BellSouth SWA Local Channel

The term "BellSouth SWA Local Channel" denotes a switched transport facility between the customer's serving wire center and the customer's premises.

BellSouth SWA WATS Serving Office

The term "BellSouth SWA WATS Serving Office" denotes a telephone company designated serving wire center where switching, screening and/or recording functions are performed in connection with the closed-end of BellSouth SWA WATS or WATS-type services.

BellSouth Telecommunications Relay Service Transport

The term "BellSouth Telecommunications Relay Service Transport" refers to the provision of a specialized telecommunications service that allows the hearing and speech impaired to communicate over the telecommunications network as defined in Part 64 of the Commission's rules.

BellSouth Telecommunications Relay Service Transport Center

The term "BellSouth Telecommunications Relay Service Transport Center" refers to the entity receiving calls and relaying those calls to the interexchange carrier of choice through the utilization of manual intervention and/or specialized equipment.

Billing Period

Each Billing Period is considered to have 30 days.

Bit

The term "Bit" denotes the smallest unit of information in the binary system of notation.

Business Day

The term "Business Day" denotes the times of day that a company is open for business. Generally, in the business community, these are 8:00 or 9:00 A.M. to 5:00 or 6:00 P.M., respectively, with an hour for lunch, Monday through Friday, resulting in a standard forty (40) hour work week. However, Business Day hours for the Telephone Company may vary based on company policy, union contract and location. To determine such hours for this company, or for an individual location within this company, contact should be made at the address shown at the top of page #1 of this tariff.

ISSUED: JUNE 16, 2011

EFFECTIVE: JULY 1, 2011

ACCESS SERVICE

2 - General Regulations (Cont'd)

2.6 Definitions (Cont'd)

Cable Space

The term "Cable Space" denotes any passage or opening in, on, under/over or through the central office cable support structure (e.g., cable risers, cable racks, cable vault or alternate splicing chamber, etc.) required to bring fire retardant fiber optic riser cable from the interconnection space to the location where the riser cable and the feeder cable meet and are spliced and the spaces between the splice and the conduit space, as well as the space between the interconnection space and the Telephone Company point of termination and any other space required to bring other fire retardant communications cable from one interconnection space module to another interconnection space module of the same collocater.

Call

The term "Call" denotes a customer attempt for which the complete address code (e.g., 0-, 911, or 10 digits) is provided to the serving dial tone office or in the case of BellSouth SWA 8XX Toll Free Dialing Ten Digit Screening Service when the address code is provided to the office performing the translation or screening function.

Carrier Identification Code (CIC)

The term "Carrier Identification Code" (CIC) denotes a unique access identification code that is assigned to an Interexchange Carrier for use with BellSouth SWA FGB and/or BellSouth SWA FGD.

ISSUED: JUNE 16, 2011

EFFECTIVE: JULY 1, 2011

ACCESS SERVICE

2 - General Regulations (Cont'd)

2.6 Definitions (Cont'd)

Carrier or Common Carrier

See Interexchange Carrier.

CCS

The term "CCS" denotes a hundred call seconds, which is a standard unit of traffic load that is equal to 100 seconds of usage or capacity of a group of servers (e.g., trunks).

CCS7 Signaling Connection

The CCS7 Signaling Connection provides a 56 kbps facility dedicated to a single customer which originates at the customer's signaling point of interconnection in a LATA and terminates at a Telephone Company Signaling Transfer Point (STP) selected by the Telephone Company. This facility, connecting the customer to a BellSouth STP, is ordered to a Telephone Company FSPOI within the same LATA as the customer's signaling point of interconnection.

CCS7 Signaling Termination

The CCS7 Signaling Termination provides a dedicated point of interface at a Telephone Company STP for a customer's CCS7 Signaling Connection.

CCS7 Access Arrangement Usage

CCS7 Signaling Arrangement Usage refers to messages traversing the Telephone Company's CCS7 Signaling network for call set-up (ISUP) and non-call set-up (TCAP) purposes.

Central Office

The term "Central Office" denotes a local Telephone Company switching system where Telephone Exchange Service customer station loops are terminated for purposes of interconnection to each other and to trunks.

Central Office Prefix

The term "Central Office Prefix" denotes the first three digits (NXX) of the seven digit telephone number assigned to an End User's Telephone Exchange Service when dialed on a local basis.

Centralized Automatic Reporting on Trunks Testing

The term "Centralized Automatic Reporting on Trunks Testing" denotes a type of testing which includes the capacity for measuring operational and transmission parameters.

ISSUED: JUNE 16, 2011

EFFECTIVE: JULY 1, 2011

ACCESS SERVICE

2 - General Regulations (Cont'd)

2.6 Definitions (Cont'd)

Centrex Type Services

The term "Centrex Type Services" denotes central office based non-transport arrangements which permit abbreviated internal calling, and inward and outward calling from station lines associated with Centrex service, ESSX-1 service, ESSX service, Digital ESSX service, MultiServ service and MultiServ PLUS service.

Channel(s)

The term "Channel(s)" denotes an electrical or photonic, in the case of fiber optic-based transmission systems, communications path between two or more points of termination.

Channel Service Unit

The term "Channel Service Unit" denotes equipment which performs one or more of the following functions: termination of a digital facility, regeneration of digital signals, detection and/or correction of signal format errors and remote loop back.

Channelization Equipment

Equipment which derives individual channels of voice and/or data from a higher capacity to a lower capacity or bandwidth or vice versa.

ISSUED: JUNE 16, 2011

EFFECTIVE: JULY 1, 2011

ACCESS SERVICE

2 - General Regulations (Cont'd)

2.6 Definitions (Cont'd)

Channelize

The term "Channelize" denotes the process of multiplexing-demultiplexing wider bandwidth or higher speed channels into narrower bandwidth or lower speed channels and vice-versa.

Clear Channel Capability

The term "Clear Channel Capability" denotes the ability to transport twenty-four 64 Kbps channels over a 1.544 Mbps High Capacity service via B8ZS line code format.

C-Message Noise

The term "C-Message Noise" denotes the frequency weighted average noise within an idle voice channel. The frequency weighting, called C-message, is used to simulate the frequency characteristic of the 500-type telephone set and the hearing of the average subscriber.

C-Notched Noise

The term "C-Notched Noise" denotes the C-message frequency weighted noise on a voice channel with a holding tone, which is removed at the measuring end through a notch (very narrow band) filter.

ISSUED: JUNE 16, 2011

EFFECTIVE: JULY 1, 2011

ACCESS SERVICE

2 - General Regulations (Cont'd)

2.6 Definitions (Cont'd)

Collocator - BellSouth Virtual Expanded Interconnection Service

The term "Collocator-BellSouth Virtual Expanded Interconnection Service" denotes any person, corporation, or other legal entity with whom the Telephone Company has negotiated for the purpose of provisioning an interconnection arrangement in accordance with the BellSouth Virtual Expanded Interconnection tariff provisions.

Collocator's Facilities - BellSouth Virtual Expanded Interconnection Service

The term "Collocator's Facilities-BellSouth Virtual Expanded Interconnection service" denotes the collocator-provided/Telephone Company leased fiber optic cables and central office terminating equipment installed and maintained by the Telephone Company for the sole use of provisioning a BellSouth Virtual Expanded Interconnection service arrangement, in accordance with the BellSouth Virtual Expanded Interconnection tariff provisions.

Common Line

The term "Common Line" denotes a line, trunk, pay telephone line or other facility provided under the general and/or local exchange service tariffs of the Telephone Company, terminated on a central office switch. A common line-residence is a line or trunk provided under the residence regulations of the general and/or local exchange service tariffs. A common line-business is a line provided under the business regulations of the general and/or local exchange service tariffs.

Commingling

The term "Commingling" means the connecting, attaching, or otherwise linking of an unbundled network element (UNE), or a combination of unbundled network elements (UNEs), to one or more facilities or services that a requesting telecommunications carrier has obtained at wholesale from an incumbent LEC, or the combining of an UNE, or a combination of UNEs, with one or more such facilities or services.

ISSUED: OCTOBER 17, 2017

EFFECTIVE: NOVEMBER 1, 2017

ACCESS SERVICE

2 - General Regulations (Cont'd)

2.6 Definitions (Cont'd)

Communications System

The term "Communications System" denotes channels and other facilities which are capable of communications between terminal equipment provided by other than the Telephone Company.

Competitive County

The term "Competitive County" denotes the geographic unit of a county or county-equivalent that either is competitive pursuant to the F.C.C.'s competitive market test or was granted Phase II, Level 2 pricing flexibility prior to June 1, 2017.

(N)
—
(N)

Conduit Space

The term "Conduit Space" denotes any reinforced passage or opening in, on, under/over or through the ground between the feeder route conduit system (entry point) and cable vault location capable of containing communications facilities, and includes: cable entrance facilities; main conduit; ducts; inner ducts; gas traps; underground dips such as short sections of conduit under roadway, driveways, parking lots and similar conduit installations; required to bring the collocater-provided fiber optic feeder cable into the Telephone Company central office.

Customer(s)

The term "Customer(s)" denotes any individual, partnership, association, joint-stock company, trust, corporation, or governmental entity or other entity which subscribes to the services offered under this tariff, including both Interexchange Carriers (ICs) and End Users.

ISSUED: JUNE 16, 2011

EFFECTIVE: JULY 1, 2011

ACCESS SERVICE

2 - General Regulations (Cont'd)

2.6 Definitions (Cont'd)

Customer Location

The term "Customer Location" denotes a customer premises within the Local Access Transport Area (LATA).

Data Transmission (107 Type) Test Line

The term "Data Transmission (107 Type) Test Line" denotes an arrangement which provides for a connection to a signal source which provides test signals for one-way testing of data and voice transmission parameters.

Decibel

The term "Decibel" denotes a unit used to express relative difference in power, usually between acoustic or electric signals, equal to ten (10) times the common logarithm of the ratio of two signal powers.

Decibel Reference Noise C-Message Weighting

The term "Decibel Reference Noise C-Message Weighting" denotes noise power measurements with C-Message Weighting in decibels relative to a reference 1000 Hz tone of 90 dB below 1 milliwatt.

Decibel Reference Noise C-Message Referenced to 0

The term "Decibel Reference Noise C-Message Referenced to 0" denotes noise power in "Decibel Reference Noise C-Message Weighting" referred to or measured at a zero transmission level point.

Derived Data Channel

The term "Derived Data Channel" denotes a digital data channel derived from a two-wire local exchange facility that transmits voice and data signals simultaneously.

ISSUED: JUNE 16, 2011

EFFECTIVE: JULY 1, 2011

ACCESS SERVICE

2 - General Regulations (Cont'd)

2.6 Definitions (Cont'd)

Detail Billing

The term "Detail Billing" denotes the listing of each message and/or Rate element for which charges to a customer are due on a bill prepared by the Telephone Company.

Directory Number

The term "Directory Number" denotes a unique NPA-NXX-XXXX assigned to a subscriber of a Local Service Provider.

Dual Tone Multifrequency Address Signaling

The term "Dual Tone Multifrequency Address Signaling" denotes a type of signaling that is an optional feature of BellSouth SWA FGA and BellSouth SWA LSBSA. It may be utilized when BellSouth SWA FGA and BellSouth SWA LSBSA is being used in the terminating direction (from the point of interface with the customer to the local exchange end office). An office arranged for Dual Tone Multifrequency Signaling would expect to receive address signals from the customer in the form of Dual Tone Multifrequency signals.

ISSUED: JUNE 16, 2011

EFFECTIVE: JULY 1, 2011

ACCESS SERVICE

2 - General Regulations (Cont'd)

2.6 Definitions (Cont'd)

DS0

This denotes a channel service expressed in terms of its digitally encoded data bit rate in accordance with the North American hierarchy of digital signal levels. It is generally referred to as having a 64 Kbps transmission data rate signal. The required format and interface specifications are contained in BellSouth Technical Reference TR-NWT-000341.

DS1

This denotes a channel service expressed in terms of its digitally encoded data bit rate in accordance with the North American hierarchy of digital signal levels. It has a 1.544 Mbps transmission data rate, and provides for the two-way simultaneous transmission of isochronous timed, Bipolar Return-to-Zero (BPRZ) bit stream format except where intentional bipolar violations are introduced by Bipolar with 8 Zero Substitution (B8ZS) format. Unframed signal formats are not permitted or compatible with Company equipment. The required format and interface specifications are contained in BellSouth Technical Reference TR-NPL-000054.

Echo Control

The term "Echo Control" denotes the control of reflected signals in a telephone transmission path.

Echo Path Loss

The term "Echo Path Loss" denotes the measure of reflected signal at a 4-wire point of termination without regard to the send and receive Transmission Level Point.

Echo Return Loss

The term "Echo Return Loss" denotes a frequency weighted measure of return loss over the middle of the voiceband (approximately 500 to 2500 Hz), where talker echo is most annoying.

Effective 2-Wire

The term "Effective 2-Wire" denotes a condition which permits the simultaneous transmission in both directions over a channel, but it is not possible to ensure independent information transmission in both directions. Effective 2-wire channels may be terminated with 2-wire or 4-wire interfaces.

ISSUED: AUGUST 29, 2016

EFFECTIVE: SEPTEMBER 13, 2016

ACCESS SERVICE

2 - General Regulations (Cont'd)

2.6 Definitions (Cont'd)

Effective 4-Wire

The term "Effective 4-Wire" denotes a condition which permits the simultaneous independent transmission of information in both directions over a channel. The method of implementing effective 4-wire transmission is at the discretion of the Telephone Company (physical, time domain, frequency-domain separation or echo cancellation techniques). Effective 4-wire channels may be terminated with a 2-wire interface at the customer's premises. However, when terminated 2-wire, simultaneous independent transmission cannot be supported because the two wire interface combines the transmission paths into a single path.

Egress Circuits

The term "Egress Circuits" denotes the facility used to transport the customer's dialed BellSouth Remote Access Service traffic to the customer's designated location once it has been collected and aggregated by the remote access server.

(D)
—
(D)

End Office Switch

The term "End Office Switch" denotes a local Telephone Company switching system where Telephone Exchange Service customer station loops are terminated for purposes of interconnection to trunks. Included are Remote Switching Modules and Remote Switching Systems served by a host office in a different wire center.

ISSUED: JUNE 16, 2011

EFFECTIVE: JULY 1, 2011

ACCESS SERVICE

2 - General Regulations (Cont'd)

2.6 Definitions (Cont'd)

End User

The term "End User" denotes any customer of an interstate or foreign telecommunications service that is not a carrier, except that a carrier other than a telephone company shall be deemed to be an "end user" when such carrier uses a telecommunications service for administrative purposes and a person or entity that offers telecommunications services exclusively as a reseller shall be deemed to be an "end user" if all resale transmissions offered by such reseller originate on the premises of such reseller.

Entry Point

The term "Entry Point" denotes the physical entrance into the central office and/or central office vault. Not all central offices have a central office vault. Multiple entry points are more than one physical entrance into the central office and/or central office vault. Normally, multiple entry points will be distinct and/or separate conduit systems.

Entry Switch

See First Point of Switching

Envelope Delay Distortion

The term "Envelope Delay Distortion" denotes a measure of the linearity of the phase versus frequency of a channel.

Equal Level Echo Path Loss

The term "Equal Level Echo Path Loss" (ELEPL) denotes the measure of Echo Path Loss (EPL) at a 4-wire interface which is corrected by the difference between the send and receive Transmission Level Point (TLP). [ELEPL = EPL - TLP (send) + TLP (receive)]

Exchange

The term "Exchange" denotes a unit generally smaller than a Local Access and Transport Area, established by the Telephone Company for the administration of communications service in a specified area which usually embraces a city, town or village and its environs. It consists of one or more central offices together with the associated facilities used in furnishing communications service within that area. One or more designated exchanges comprise a given Local Access and Transport Area.

ISSUED: JUNE 30, 2020

EFFECTIVE: JULY 15, 2020

ACCESS SERVICE

2 - General Regulations (Cont'd)

2.6 Definitions (Cont'd)

Exchange Access Frame Relay Service (a.k.a. BellSouth Exchange Access Frame Relay Service)⁽¹⁾

The term "Exchange Access Frame Relay Service "(a.k.a. BellSouth Exchange Access Frame Relay Service) denotes a connection oriented packet-switched data service for the interconnection of local area networks (LANs) or other compatible customer equipment.

Expected Measured Loss

The term "Expected Measured Loss" denotes a calculated loss which specifies the end-to-end 1004-Hz loss on a terminated test connection between two readily accessible manual or remote test points. It is the sum of the inserted connection loss and test access loss including any test pads.

Fast Packet Access Services

The term "Fast Packet Access services" denotes high speed connectivity over a wide geographic area. Fast packet services use digital transmission facilities and switching technology to provide high speed information transfers for users with large bandwidth requirements. Fast Packet technology divides data into blocks (packets) with fixed maximum lengths. These packets are transported through the Company's network. Each packet contains the necessary information to ensure accurate data transfer to its destination.

Facility Signaling Point of Interconnection (FSPOI)

The term FSPOI denotes a Telephone Company-designated ordering point within a Telephone Company LATA to which customers may order CCS7 Signaling Connections.

Federal Observed Holiday

The term "Federal Observed Holiday" denotes public holidays for Federal employees as established by Federal Law (5 U.S.C. 6103).

⁽¹⁾ Effective November 5, 2011, Exchange Access Frame Relay Service (XAFRS) (a.k.a. BellSouth Exchange Access Frame Relay Service) as described in Section 21.2, following, will no longer be available to new Customers. Existing term plan Customers, as of November 5, 2011, may add, move, remove or change lines and/or locations for the durations of their current term plan agreements, but may not enter into any new term plan agreements. Existing Customers will be permitted one extension of any existing, non-expired term plan agreement past its current term for twelve (12) months, provided the extension is signed on or before March 31, 2012. Upon expiration of any term plan agreement (including any permitted extension), service will continue on a month-to-month basis until the service is discontinued by the Telephone Company.

ISSUED: JUNE 16, 2011

EFFECTIVE: JULY 1, 2011

ACCESS SERVICE

2 - General Regulations (Cont'd)

2.6 Definitions (Cont'd)

Field Identifier

The term "Field Identifier" denotes two to four characters that are used on service orders to convey specific instructions. Field Identifiers may or may not have associated data. Selected Field Identifiers are used in Telephone Company billing systems to generate nonrecurring charges.

First-Come, First-Served

The term "First-Come, First-Served" denotes a procedure followed when the first service order received will be the first service order processed.

First Point of Switching

The term "First Point of Switching" denotes the first Telephone Company location at which switching occurs on the terminating path of a call proceeding from the customer premises to the terminating end office and, at the same time, the last Telephone Company location at which switching occurs on the originating path of a call proceeding from the originating end office to the customer premises.

Floor Space - BellSouth Virtual Expanded Interconnection Service

The term "Floor Space" denotes the central office floor space required to provision a BellSouth Virtual Expanded Interconnection Service arrangement, including environmental support and power, for interconnection to Telephone Company-provided services and facilities.

Frequency Shift

The term "Frequency Shift" denotes the change in the frequency of a tone as it is transmitted over a channel.

Grandfathered

The term "Grandfathered" denotes Terminal Equipment, Multiline Terminating Systems and Protective Circuitry directly connected to the facilities utilized to provide services under the provisions of this tariff, and which are considered grandfathered under Part 68 of the F.C.C.'s Rules and Regulations.

Host Office

The term "Host Office" denotes an electronic switching system which provides call processing capabilities for one or more Remote Switching Modules or Remote Switching Systems.

ISSUED: AUGUST 11, 2014

EFFECTIVE: AUGUST 26, 2014

ACCESS SERVICE

2 - General Regulations (Cont'd)

2.6 Definitions (Cont'd)

Hub

(T)

The term "Hub" denotes a Telephone Company designated location at which services are either joined together (as in a bridging hub) or where services are channelized (as in a Hi-Capacity hub). A hub office may be further designated as a Digital Data Access Service (DDAS) hub through which DDAS is available for provisioning. Hubs for specific services are designated in NECA (T) TARIFF F.C.C. NO. 4.

Immediately Available Funds

The term "Immediately Available Funds" denotes a corporate or personal check drawn on a bank account and funds which are available for use by the receiving party on the same day on which they are received and include U.S. Federal Reserve bank wire transfers, U.S. Federal Reserve notes (paper cash), U.S. coins, U.S. Postal Money Orders and New York Certificates of Deposit.

Impedance Balance

The term "Impedance Balance" denotes the method of expressing Echo Return Loss and Singing Return Loss at a 4-wire interface whereby the gains and/or loss of the 4 wire portion of the transmission path, including the hybrid, are not included in the specification.

Impulse Noise

The term "Impulse Noise" denotes any momentary occurrence of the noise on a channel over a specified level threshold. It is evaluated by counting the number of occurrences which exceed the threshold.

Individual Case Basis

The term "Individual Case Basis" denotes a condition in which the regulations, if applicable, rates and charges for an offering under the provisions of this tariff are developed based on the circumstances in each case.

Ingress Circuits

The term "Ingress Circuits" denotes the facility used to transport the customer's incoming dialed BellSouth Remote Access Service traffic, e.g. PRI.

Inserted Connection Loss

The term "Inserted Connection Loss" denotes the 1004 Hz power difference (in dB) between the maximum power available at the originating end and the actual power reaching the terminating end through the inserted connection.

ISSUED: JUNE 16, 2011

EFFECTIVE: JULY 1, 2011

ACCESS SERVICE

2 - General Regulations (Cont'd)

2.6 Definitions (Cont'd)

Interconnection

Interconnection denotes the several Interconnection rate elements that apply to BellSouth SWA minutes of use. Separate rate elements are applicable for originating and terminating minutes of use. Additionally, separate rate elements are applicable when the customer utilizes Telephone Company-provided transport facilities versus those service applications where there are no Telephone Company transport facilities utilized.

Interexchange Carrier (IC) or Interexchange Common Carrier

The terms "Interexchange Carrier" (IC) or "Interexchange Common Carrier" denotes any individual, partnership, association, joint-stock company, trust, governmental entity or corporation engaged for hire in interstate or foreign communication by wire or radio, between two or more exchanges.

Intermodulation Distortion

The term "Intermodulation Distortion" denotes a measure of the nonlinearity of a channel. It is measured using four tones, and evaluating the ratios (in dB) of the transmitted composite four-tone signal power to the second-order products of the tones (R2), and the third-order products of the tones (R3).

Interstate Communications

The term "Interstate Communications" denotes both interstate and foreign communications.

Intrastate Communications

The term "Intrastate Communications" denotes any communications within a state subject to oversight by a state regulatory commission as provided by the laws of the state involved.

ISSUED: JUNE 16, 2011

EFFECTIVE: JULY 1, 2011

ACCESS SERVICE

2 - General Regulations (Cont'd)

2.6 Definitions (Cont'd)

Line Controlled Pay Stations

Line controlled pay stations utilize Telephone Company serving central office equipment for the necessary call processing features required for pay phone traffic. Traffic from these stations will be completed to the customer over BellSouth SWA FGD or BellSouth SWA TSBSA 3 trunks which must be equipped with the Coin Sent-Paid Capability optional feature.

ISSUED: JUNE 16, 2011

EFFECTIVE: JULY 1, 2011

ACCESS SERVICE

2 - General Regulations (Cont'd)

2.6 Definitions (Cont'd)

Line-Side Connection

The term "Line-Side Connection" denotes a connection of a transmission path to the line side of a local exchange switching system.

Local Access and Transport Area

The term "Local Access and Transport Area" denotes a geographic area established for the provision and administration of communications service. It encompasses one or more designated exchanges, which are grouped to serve common social, economic and other purposes.

Local Calling Area

The term "Local Calling Area" denotes a geographical area, as defined in the Telephone Company's General Subscriber Service Tariff, in which an end user (Telephone Exchange Service Subscriber) may complete a call without incurring MTS charges.

Location Routing Number

The term "Location Routing Number" (LRN) denotes a 10-digit number used to uniquely identify a switch that serves ported numbers.

Local Tandem Switch

The term "Local Tandem Switch" denotes a local Telephone Company switching unit by which local or access telephonic communications are switched to and from an End Office Switch.

Location Provider

A location provider is the person or persons having legal authority to permit the Payphone Service Provider to place pay telephones on their premises.

Loop Around Test Line

The term "Loop Around Test Line" denotes an arrangement utilizing a Telephone Company central end office to provide a means to make certain two-way transmission tests on a manual basis. This arrangement has two central office terminations, each reached by means of separate telephone numbers and does not require any specific customer premises equipment. Equipment subject to this test arrangement is at the discretion of the customer.

ISSUED: APRIL 25, 2013

EFFECTIVE: MAY 10, 2013

ACCESS SERVICE

2 - General Regulations (Cont'd)

2.6 Definitions (Cont'd)

Loss Deviation

The term "Loss Deviation" denotes the variation of the actual loss from the designed value.

Major Fraction Thereof

The term "Major Fraction Thereof" is any period of time in excess of 1/2 of the stated amount of time. As an example, in considering a period of 24 hours, a major fraction thereof would be any period of time in excess of 12 hours exactly. Therefore, if a given service is interrupted for a period of thirty six hours and fifteen minutes, the customer would be given a credit allowance for two twenty-four hour periods for a total of forty-eight hours.

Manhole

The term "Manhole" denotes a sub-surface enclosure which personnel may enter and use for the purpose of installing, operating, maintaining and repairing communications facilities.

(D)
—
(D)

Message

The term "Message" denotes a "call" as defined, preceding.

(T)

Milliwatt (102 Type) Test Line

The term "Milliwatt (102 Type) Test Line" denotes an arrangement in an end office which provides a 1004 Hz tone at 0 dBm0 for one-way transmission measurements towards the customer's premises from the Telephone Company end office.

Minutes of Use (See Access Minutes)

Mobile Telephone Switching Office (MTSO)

The term "Mobile Telephone Switching Office (MTSO)" denotes a Cellular Mobile Carrier (CMC) switching system that is used to terminate mobile stations for purposes of interconnection to each other and to trunks interfacing with the public switched network.

ISSUED: OCTOBER 17, 2017

EFFECTIVE: NOVEMBER 1, 2017

ACCESS SERVICE

2 - General Regulations (Cont'd)

2.6 Definitions (Cont'd)

Multipoint Channel

The term "Multipoint Channel" refers to any connection which terminates three or more circuits on the same bridging node.

N-1 Carrier

The term "N-1 Carrier", used in connection with BellSouth Local Number Portability Database Services, denotes the telecommunications carrier immediately preceding the terminating carrier.

Network Channel Interface (NCI) Code Update

The term "Network Channel Interface (NCI) Code Update" denotes the manual or mechanical activity performed to update the NCI code on each sub-DS1 level circuit riding a DS1 High Capacity (a.k.a. BellSouth SPA DS1) service that is converted (rolled over) to a DS3 High Capacity (a.k.a. BellSouth SPA DS3) service.

Network Control Signaling

The term "Network Control Signaling" denotes the transmission of signals used in the telecommunications system which perform functions such as supervision (control, status, and charge signals), address signaling (e.g., dialing), calling and called number identifications, rate of flow, service selection error control and audible tone signals (call progress signals indicating re-order or busy conditions, alerting, coin denominations, coin collect and coin return tones) to control the operation of the telecommunications system.

Non-Competitive County

The term "Non-Competitive County" denotes the geographic unit of a county or county-equivalent that neither is competitive pursuant to the F.C.C.'s competitive market test nor was subject to Phase II, Level 2 pricing flexibility prior to June 1, 2017.

(N)
|
(N)

Nonsynchronous Test Line

The term "Nonsynchronous Test Line" denotes an arrangement in step-by-step end offices which provides operational tests which are not as complete as those provided by the synchronous test lines, but can be made more rapidly.

North American Numbering Plan

The term "North American Numbering Plan" denotes a three-digit area (Numbering Plan Area) code and a seven-digit telephone number made up of a three-digit Central Office code plus a four-digit station number.

Off-hook

The term "Off-hook" denotes the active condition of Switched Access or a Telephone Exchange Service line.

ISSUED: JUNE 16, 2011

EFFECTIVE: JULY 1, 2011

ACCESS SERVICE

2 - General Regulations (Cont'd)

2.6 Definitions (Cont'd)

On-hook

The term "On-hook" denotes the idle condition of BellSouth SWA or a Telephone Exchange Service line.

Open Circuit Test Line

The term "Open Circuit Test Line" denotes an arrangement in an end office which provides an ac open circuit termination of a trunk or line by means of an inductor of several Henries.

Operator Services System

The term "Operator Services System" (OSS) denotes the switching equipment, facilities, operator positions and software components utilized for the provision of Operator Services.

Operator Services System Location

The term "Operator Services System Location" (OSS location) denotes a Telephone Company office where Telephone Company equipment routes or receives customer Operator Services calls to or from the customer location.

Operator Services System Serving Area

The term "Operator Services System Serving Area" (OSS serving area) denotes the geographic operational domain of an Operator Services System.

Originating Direction

The term "Originating Direction" denotes the use of Access Service for the origination of calls from an end user premises to a customer premises.

Overlap Outpulsing

The term "Overlap Outpulsing" denotes the feature of the Feature Group D Signaling System which permits initiation of pulsing to the customer's premises before the calling subscriber has completed dialing an originating call.

ISSUED: JUNE 30, 2020

EFFECTIVE: JULY 15, 2020

ACCESS SERVICE

2 - General Regulations (Cont'd)

2.6 Definitions (Cont'd)

Pay Telephone Line

The term "Pay Telephone Line" denotes facilities provided by the Telephone Company which connect pay telephone stations to the Local Exchange network.

Payphone Service Provider

The term "Payphone Service Provider" denotes one who provides payphone service, which is the provision of public or semi-public pay telephone, the provision of inmate telephone service in correctional institutions and any ancillary services.

Phase Jitter

The term "Phase Jitter" denotes the unwanted phase variations of a signal.

Point of Termination

The term "Point of Termination" denotes the point of demarcation, within a customer-designated premises at which the Telephone Company's responsibility for the provision of Access Service ends.

Ported Number

The term "Ported Number" denotes a unique Directory Number retained by a subscriber who has changed Local Service Providers.

Premises

The term "Premises" denotes a building, or a portion of a building in a multi-tenant building, or buildings on continuous property (except Railroad Right-of-way, etc.) not separated by a public highway, except for an end user that offers Telecommunications Services exclusively as a reseller. This term is not to be limited to one building, but applies as well to a complex, or campus-type configuration of buildings. For application of the FUS and EUCL Charges pursuant to Sections 3 and 4 following, each dormitory room served by a central office-based local exchange service shall be considered a premises.

ISSUED: JUNE 16, 2011

EFFECTIVE: JULY 1, 2011

ACCESS SERVICE

2 - General Regulations (Cont'd)

2.6 Definitions (Cont'd)

Primary Residential Local Exchange Service ("Primary Residential Line")

This term denotes the earliest ordered Residential Local Exchange Service ("residential line") provided by the Telephone Company or a reseller of a Telephone Company-provided residential line at an end user's residential premises. In the case that multiple residential lines are ordered at the same time at a residential premises without existing residential lines, the Primary Residential Line is that residential line to which the first telephone number is assigned. In the event the Primary Residential Line is disconnected at a residential premises served by more than one residential line, the Telephone Company will deem the Primary Line designation to the residential line to which the second telephone number was assigned. In the event an end user simultaneously orders residential lines from both the Telephone Company and one or more resellers of Telephone Company-provided residential service, the line provided by the Telephone Company will be deemed the Primary Residential Line. The Primary Residential Line FUS or EUCL charge is assessed to the Primary Residential Line.

Query

The term "Query" denotes a Common Channel Signaling (CCS) message which, when appropriately sent, represents a request for validation of data.

Radio Common Carriers (RCCs)

The term "Radio Common Carriers (RCCs)" denotes carriers which are regulated under Part 22 of the Federal Communications Commission's Rules and Regulations.

ISSUED: JUNE 16, 2011

EFFECTIVE: JULY 1, 2011

ACCESS SERVICE

2 - General Regulations (Cont'd)

2.6 Definitions (Cont'd)

Registered Equipment

The term "Registered Equipment" denotes the customer's premises equipment which complies with and has been approved within the Registration Provisions of Part 68 of the F.C.C.'s Rules and Regulations.

Remote Access Server

The term "Remote Access Server" denotes equipment that aggregates the customer's BellSouth Remote Access Service dial traffic and transports it to the customer's designated location over their egress circuits.

Remote Switching Modules and/or Remote Switching Systems

The term "Remote Switching Modules and/or Remote Switching Systems" denotes small, remotely controlled electronic end office switches which obtain their call processing capability from an ESS-type Host Office.

Return Loss

The term "Return Loss" denotes a measure of the similarity between the two impedances at the junction of two transmission paths. The higher the return loss, the higher the similarity.

Secondary Channel

The term "Secondary Channel" denotes the offering of a companion digital transmission capability over the same physical facility as the primary channel at a lower bit rate. Terminal equipment required to support secondary channel capability must be provided by the customer.

Service Control Point (SCP)

The term "Service Control Point" denotes a node (translation processor based system) which provides interface and support functions in the provision of network services.

Service Installation Guarantee

The term "Service Installation Guarantee" denotes a program under which the Telephone Company will provide a credit to the customer's account for certain services in those instances when the Service Date is not met due to Telephone Company reasons.

ISSUED: JUNE 16, 2011

EFFECTIVE: JULY 1, 2011

ACCESS SERVICE

2 - General Regulations (Cont'd)

2.6 Definitions (Cont'd)

Service Provided Upon Request

The term "Service Provided Upon Request" (SPUR) denotes a service that has not been requested by any customers in a particular state. When a request for this service is received, a new aggregate rate will be calculated and filed in this tariff. The new rate will include the additional demand and costs for the service.

Service Switching Point (SSP)

The term "Service Switching Point" (SSP) denotes a node in a CCS7 Signaling System that formulates and receives signaling messages.

ISSUED: JUNE 16, 2011

EFFECTIVE: JULY 1, 2011

ACCESS SERVICE

2 - General Regulations (Cont'd)

2.6 Definitions (Cont'd)

Serving Wire Center

The term "Serving Wire Center" denotes the wire center from which the customer designated premises would normally obtain dial tone from the Telephone Company.

Seven Digit Manual Test Line

The term "Seven Digit Manual Test Line" denotes an arrangement which allows the customer to select balance, milliwatt and synchronous test lines by manually dialing a seven digit number over the associated access connection.

Shared Network Arrangement

The term "Shared Network Arrangement" denotes a service offering whereby multiple customers may cross connect on a channelized High Capacity (a.k.a. BellSouth SPA High Capacity) service and the Telephone Company will undertake to maintain separate records for each customer's portion of the shared network.

Short Circuit Test Line

The term "Short Circuit Test Line" denotes an arrangement in an end office which provides for an ac short circuit termination of a trunk or line by means of a capacitor of at least four microfarads.

Signal-to-C-Notched Noise Ratio

The term "Signal-to-C-Notched Noise Ratio" denotes the ratio in dB of a test signal to the corresponding C-Notched Noise.

Signal Transfer Point

The term "Signal Transfer Point" denotes a signaling point which routes and/or transfers signaling messages through the common channel signaling network.

(Signaling) Point Code

The term "Signaling Point Code" denotes a binary code uniquely identifying a signaling point in a signaling network. This code is used, depending upon its position in the label, either as a destination point code, identifying the intended destination of the message, or as an originating point code, identifying the originating point of the message.

Signaling Point of Interconnection (SPOI)

The term Signaling Point of Interconnection (SPOI) denotes the location where a Telephone Company-provided CCS7 Signaling Connection terminates at a customer location.

ISSUED: AUGUST 29, 2016

EFFECTIVE: SEPTEMBER 13, 2016

ACCESS SERVICE

2 - General Regulations (Cont'd)

2.6 Definitions (Cont'd)

Singing Return Loss

The term "Singing Return Loss" denotes the frequency weighted measure of return loss at the edges of the voiceband (200 to 500 Hz and 2500 to 3200 Hz), where singing (instability) problems are most likely to occur.

Space Construction Charge

The term "Space Construction Charge" denotes all work in accordance with BellSouth Telecommunications Practices and performed by BellSouth Telecommunications or Telephone Company-approved contractors, including but not limited to, space design and preparation, design and preparation of interconnection floor space enclosure, design and placement of required environmental, electrical, and fire safety support features, design and placement of required support structures of any other activity required to accommodate the installation of collocator's facilities in the Telephone Company's interconnection space(s) covered under this tariff.

Space Preparation Charge

The term "Space Preparation Charge" denotes all work involving order processing for interconnection space including interexchange carrier service center activities, network coordination activities, and outside plant provisioning activities between the central office manhole and the interconnection space.

Special Order

The term "Special Order" denotes an order for a BellSouth Directory Assistance Access service, BellSouth Operator Services Access service, or a BellSouth Line Information Data Base Access service when the service is provided: Via direct trunks to the BellSouth Directory Assistance location or to an OSS location; or, for BellSouth Directory Assistance Access service, via specially designated trunk groups to the access tandem; or, for BellSouth Line Information Data Base Access Service, via specially designated facilities to a designated BellSouth Line Information Data Base Location. (D) (D)

Subtending End Office of an Access Tandem

The term "Subtending End Office of an Access Tandem" denotes an end office that has final trunk group routing through that tandem.

ISSUED: JUNE 16, 2011

EFFECTIVE: JULY 1, 2011

ACCESS SERVICE

2 - General Regulations (Cont'd)

2.6 Definitions (Cont'd)

Synchronous Test Line

The term "Synchronous Test Line" denotes an arrangement in an end office which performs marginal operational tests of supervisory and ring-tripping functions.

Telephone Company Answering Service Concentrator

The term "Telephone Company Answering Service Transport Concentrator" denotes a device located in a central office of the Telephone Company which concentrates incoming calls to some number of Telephone Answering Service's client lines to some smaller number of trunks/channels connected to the customer's premises equipment.

Terminating Direction

The term "Terminating Direction" denotes the use of Access Service for the completion of calls from a customer premises to an end user premises.

ISSUED: MARCH 2, 2020

EFFECTIVE: MARCH 17, 2020

ACCESS SERVICE

2 - General Regulations (Cont'd)

2.6 Definitions (Cont'd)

Toll Free Dialing Database

The term "Toll Free Dialing (TFD) Database" refers to the use of database technology to determine to which access customer an originating TFD call is to be delivered. An originating TFD call is a call made with the prefix 1+800, 1+888, 1+877, 1+866, 1+855, 1+844, 1+833 OR 1+822. These calls may also be referred to as 8XX calls. The TFD Database routes calls to an access customer based on the dialed ten digit TFD number. Initially, the Toll Free Dialing Database will provide routing information for calls utilizing 800 and 888 toll free dialing numbers. The Toll Free Dialing Database will be expanded, as required, at a later date to include routing for 877, 855, 844, 833 and 822 toll free dialing numbers. Until that time, toll free dialing calls, other than those originated as 1+800 or 1+888, will not be completed.

Traceback Request

A request for information from the Customer about traffic which it has sent to the Telephone Company and which traffic is reasonably believed by the Telephone Company to be unlawful and abusive traffic, and which request requires a response indicating whether the Customer is the Originating Provider or whether Customer received the calls from another voice provider.

(N)
|
(N)

Traditional Signaling

The term "Traditional Signaling" denotes the Intermachine Signaling System which has been traditionally used in North America for the purpose of transmitting the called number's address digits from the originating end office to the switching machine which will terminate the call. In this system, all of the dialed digits are received by the originating switching machine, a path is selected, and the sequence of supervisory signals and outpulsed digits is initiated. No overlap outpulsing, ten digit ANI or ANI information digits are included in this signaling sequence. Acknowledgment wink is required from the terminating switch machine except when the originating switch machine is SXS.

Traffic

The term "traffic" denotes a volume of customer access minutes of use or calls.

Traffic Operator Position System (TOPS) Tandem

The term "Traffic Operator Position System" (TOPS tandem) denotes a Telephone Company office where Telephone Company equipment routes or receives customer Operator Services calls to or from the customer location. A TOPS tandem is also known as an OSS location.

Transactions Capabilities Application Part (TCAP) Messages

The term "TCAP Messages" relates to the application of TIA Interim Standard 41 (Sub-systems 005-010) for the transmission of non-call associated messages over the CCSAC network.

ISSUED: JUNE 16, 2011

EFFECTIVE: JULY 1, 2011

ACCESS SERVICE
2 - General Regulations (Cont'd)

2.6 Definitions (Cont'd)

Transmission Measuring (105 Type) Test Line/Responder

The term "Transmission Measuring (105 Type) Test Line/Responder" denotes an arrangement in an end office which provides far-end access to a responder and permits two-way loss and noise measurements to be made on trunks from a near end office.

Transmission Path

The term "Transmission Path" denotes an electrical path capable of transmitting signals within the range of the service offering, e.g., a voice grade transmission path is capable of transmitting voice frequencies within the approximate range of 300 to 3000 Hz. A transmission path is comprised of physical or derived channels consisting of any form or configuration of facilities typically used in the telecommunications industry.

Trunk

The term "Trunk" denotes a communications path connecting two switching systems in a network, used in the establishment of an end-to-end connection.

Trunk Group

The term "Trunk Group" denotes a set of trunks which are traffic engineered as a unit for the establishment of connections between switching systems in which all of the communications paths are interchangeable.

Trunk-Side Connection

The term "Trunk-Side Connection" denotes the connection of a transmission path to the trunk side of a local exchange switching system.

Two-Wire to Four-Wire Conversion

The term "Two-Wire to Four-Wire Conversion" denotes an arrangement which converts a four-wire transmission path to a two-wire transmission path to allow a four-wire facility to terminate in a two-wire entity (e.g., a central office switch).

Unbundled Network Elements (UNEs)

The term "Unbundled Network Elements" denotes the physical facilities of the network, including the associated features, functions and capabilities, that are capable of being used in the provision of a telecommunications service, made available pursuant to Section 251 of the Telecommunications Act of 1996.

ISSUED: AUGUST 29, 2016

EFFECTIVE: SEPTEMBER 13, 2016

ACCESS SERVICE

2 - General Regulations (Cont'd)

2.6 Definitions (Cont'd)

Uniform Service Order Code (USOC)

The term "Uniform Service Order Code" denotes a three or five character alphabetic, numeric, or an alphanumeric code that identifies a specific item of service or equipment. Uniform Service Order Codes are used in the Telephone Company billing system to generate recurring rates and nonrecurring charges.

Unusable Service

A customer's service is considered unusable when it becomes inoperative to the customer because of a failure of a facility component used to furnish service under this tariff or when service fails to meet the technical performance specifications as set forth by this tariff.

V and H Coordinates Method

The term "V and H Coordinates Method" denotes a method of computing airline miles between two points by utilizing an established formula which is based on the vertical and horizontal coordinates of the two points.

(D)
—
(D)

Wire Center

The term "Wire Center" denotes a building in which one or more central offices, used for the provision of Telephone Exchange Services, are located.

BELLSOUTH TELECOMMUNICATIONS
Four AT&T Plaza, Dallas, Texas 75202

TARIFF F.C.C. NO. 1
1ST REVISED PAGE 2-194
CANCELS ORIGINAL PAGE 2-194

ISSUED: JANUARY 31, 2024

EFFECTIVE: FEBRUARY 6, 2024

ACCESS SERVICE

2 - GENERAL REGULATIONS (CONT'D)

(Dx)

(Dx)

(x) Issued under authority of Special Permission No. 24-001 of the FCC in order to withdraw material filed under Transmittal No. 183 without its becoming effective and to restore currently effective material.

(This page filed under Transmittal No. 184)
