

ACCESS SERVICE

	<u>Page No.</u>
6. <u>SWITCHED ACCESS SERVICE</u>	
6.1 <u>General</u>	6-4
6.1.1 Switched Access Service Arrangements and Manner of Provision	6-5
6.1.2	6-18
6.1.3 Rate Categories	6-18
6.1.6 Acceptance Testing	6-50
6.1.7 CCSAC and 64 CCC Testing Requirements	6-50
6.2 <u>Provision and Description of Switched Access Service</u>	6-51
6.2.1 Feature Group A (FGA)	6-52
6.2.2 Feature Group B (FGB)	6-58
6.2.3	
6.2.4 Feature Group D (FGD)	6-68
6.2.5 Line Information Data Base (LIDB) Service	6-78
6.2.6 900 Access Service	6-86
6.2.7 X.25 ⁽¹⁾	6-89
6.2.8 Access Line Arrangement (ALA)	6-95
6.2.9 Access Trunk Arrangement (ATA)	6-100
6.2.10 Access Trunk Arrangement-950 (ATA-950)	6-100
6.2.11 Access Trunk Arrangement-10X (ATA-101XXXX)	6-105
6.2.12 Direct Inward Dial (DID)	6-113
6.2.13 Toll Free Access Service	6-117
6.2.14 500 Access Service	6-120
6.3 <u>Local Switching Optional Features and BSEs</u>	6-122
6.3.1 Common Switching	6-122
6.3.2 Transport Termination	6-143
6.3.3 WATS Access Line Termination	6-147
6.4 <u>Transmission Specifications</u>	6-149

(D)

(1) As of October 6, 2004, X.25 and X.75 protocols are obsolete and limited to existing installations, at existing locations, for existing customers.

(This page filed under Transmittal No. 489)

Issued: May 2, 2013

Effective: May 17, 2013

Four AT&T Plaza, Dallas, Texas 75202

ACCESS SERVICE

	<u>Page No.</u>	
6. <u>SWITCHED ACCESS SERVICE</u> (Cont'd)		
6.5 <u>Obligations of the Telephone Company</u>	6-150	
6.5.1 Network Management	6-150	
6.5.2 Reserved for Future Use	6-151	(D)
6.5.3 Trunk Group Measurements Report	6-152	
6.5.4	6-153	
6.5.5	6-153	
6.5.6 Design Blocking Probability	6-153	
6.5.7 Provision of Service Performance Data	6-157	
6.6 <u>Obligations of the Customer</u>	6-158	
6.6.1 Report Requirements	6-158	
6.6.2 Supervisory Signaling	6-159	
6.6.3 CCSAC Measurement Data	6-160	
6.6.4 Trunk Group Measurements Reports	6-160	
6.6.5 Design of Switched Access Services	6-160	
6.6.6 Outbound Messaging Application	6-160	
6.7 <u>Rate Regulations</u>	6-161	
6.7.1 Description and Application of Rates and Charges	6-161	
6.7.2		
6.7.3		
6.7.4 Minimum Period Charge	6-180	
6.7.5		
6.7.6 Change of Feature Group or Access Arrangement Type	6-181	
6.7.7		
6.7.8 Measuring Access Minutes	6-184	
6.7.9	6-193	
6.7.10 Application of Rates for ALA and Feature Group A Extension Service	6-193	
6.7.11 Message Unit Credit	6-194	
6.7.12 Community Information Services	6-194	
6.7.13 Mileage Measurement	6-195	
6.7.14		
6.7.15 Shared Use	6-199	
6.7.16	6-200	
6.7.17 Information Surcharge	6-200	
6.7.18 Billing Name and Address (BNA) Service	6-201	

(This page filed under Transmittal No. 550)

ACCESS SERVICE

	<u>Page No.</u>
6. <u>SWITCHED ACCESS SERVICE</u> (Cont'd)	
6.8 <u>Rates and Charges</u>	6-203
6.8.1 X.25 Charges ⁽¹⁾	6-203
6.8.2 Switched Transport	6-206
6.8.3 Local Switching for Feature Groups	6-220
6.8.4	6-229
6.8.5 Local Switching for Access Arrangements	6-229
6.8.6 Message Unit Credit	6-239
6.8.7 Reserved	6-239
6.8.8 Information Surcharge	6-239
6.8.9 Line Information Data Base (LIDB) Service	6-240
6.8.10 SS7 Interconnection	6-240
6.8.11 DID Switched Access Service	6-241
6.8.12 Toll Free Access Service	6-242
6.8.13 Billing Name and Address (BNA) Service	6-242
6.8.14 500 Access Service	6-242
6.8.15 Outbound Messaging Application	6-243

(N)

(1) As of October 6, 2004, X.25 and X.75 protocols are obsolete and limited to existing installations, at existing locations, for existing customers.

(This page filed under Transmittal No. 285)

Issued: April 26, 2006

Effective: April 27, 2006

Four AT&T Plaza, Dallas, Texas 75202

ACCESS SERVICE

6. Switched Access Service

6.1 General

Switched Access Service provides a two-point communication path between a customer's premises and an end user's premises through the use of common terminating, common switching, Switched Transport facilities and common subscriber plant of the Telephone Company. Switched Access Services may not be used as substitutes for the Telephone Company's local and/or general exchange services. Switched Access Service provides for the ability to originate calls from an End User's premises to a customer's designated premises, or to Expanded Interconnection Service and to terminate calls from a customer's designated premises, or Expanded Interconnection Service to an End User's premises in the LATA where it is provided. Specific references to material describing the elements of Switched Access Service are provided in 6.1.1 and 6.1.3 following.

Rates and charges for Switched Access Service are set forth in 6.8 following. Rates and charges for Switched Access/Dedicated Transport are set forth in Section 6.8 following, with the exception of the services provided by the Telephone Company in the Metropolitan Statistical Areas (MSAs) in which the Telephone Company has received Phase II pricing flexibility pursuant to Subpart H of Part 69 of the Commission's Rules. The rates and charges for the Switched Access/Dedicated Transport services in the MSAs that have received Phase II pricing flexibility are set forth in Section 31.

(N)
|
(N)

The application of rates for Switched Access Service is described in 6.7 following. Rates and charges for services other than Switched Access customer's interLATA toll message service, may also be applicable when Switched Access Service is used in conjunction with these other services. Descriptions of such applicability are provided in 6.2.

(This page filed under Transmittal No. 115)

ACCESS SERVICE

6. Switched Access Service (Cont'd)

6.1 General (Cont'd)

6.1.1 Switched Access Service Arrangements and Manner of Provision

(A) Switched Access Service Arrangements

Switched Access Service is provided in the form of access arrangements of optional features and Basic Service Elements (BSEs) called (1) Access Line Arrangement (ALA), (2) Access Trunk Arrangement with two switched access options ATA-950 and ATA-101XXXX, (3) Direct Inward Dialed PBX Trunk, (4) Dedicated Network Access Link and in three optional service arrangements of standard and optional features called (1) Feature Group A (FGA), (2) Feature Group B (FGB), and (3) Feature Group D (FGD). In addition 500, 8yy (Toll Free Service) and 900 Access Services are available through the use of ATA-101XXXX and Feature Group D.

(C)
(D)
(T)
(T)

The arrangements are differentiated by their technical characteristics, e.g., line side vs. trunk side connection at the Telephone Company entry switch, and the manner in which an end user accesses them in originating calling, e.g., with or without an access code. A description of ALA, ATA-950 and ATA-101XXXX, DID, DNAL and each Feature Group is in 6.2 following. Descriptions of the 500, 8yy and 900 Access Services are in 6.2. following.

(T)

(This page filed under Transmittal No. 371)

ACCESS SERVICE

6. Switched Access Service (Cont'd)

(M)

6.1 General (Cont'd)

6.1.1 Switched Access Service Arrangements and Manner of Provision
(Cont'd)

(A) Switched Access Service Arrangements (Cont'd)

UNIFORM ONA SERVICE NAME CROSS REFERENCE

The following matches the Telephone Company's Basic Service Element (BSE) names to the industry standard feature names for each BSE.

<u>PACIFIC BELL</u>	<u>UNIFORM ONA SERVICE NAME</u>
Automatic Number Identification	Calling Billing Number Delivery -FGD Protocol
Hunt Group Arrangement	Multiline Hunt Group
Hunt Group - C.O. Announcement	Multiline Hunt Group - C.O. Announcements
Uniform Call Distribution (UCD) - Uniform Arrangement Hunting	Multiline Hunt Group - Call Distribution Line
Uniform Call Distribution With Queuing	Multiline Hunt Group - UCD Queuing
Hunt Group Overflow	Multiline Hunt Group - Overflow
Nonhunting Number for Use with Individual Hunt Group or Uniform Call Group Distribution Arrangement	Multiline Hunt Group - Access to Each Port in Hunt
Three Way Call Transfer	Three Way Call Transfer
Answer Supervision - Lineside Line	Answer Supervision with a Side Interface
Direct Inward Dialing - Circuit Termination	Called Directory Number Delivery via DID
DID Trunk Queuing	DID Trunk Queuing
Calling Number Delivery via ICLID	Calling Number Delivery

Material on this page previously appeared on Original Page 6-11.

(M)

(This page filed under Transmittal No. 365)

ACCESS SERVICE

6. Switched Access Service (Cont'd)

(M)

6.1 General (Cont'd)

6.1.1 Switched Access Service Arrangements and Manner of Provision (Cont'd)

(A) Switched Access Service Arrangements (Cont'd)

UNIFORM ONA SERVICE NAME CROSS REFERENCE

The following matches The Telephone Company's Basic Service Element (BSE) names to the industry standard feature names for each BSE.

<u>PACIFIC BELL</u>	<u>UNIFORM ONA SERVICE NAME</u>
Public Packet Switching Fast Select Acceptance	Fast Select Acceptance - Packet
Fast Select - Initiate	Fast Select Request - Packed
Closed User Groups	Closed User Group - Packet
Hunt Group - Internal	Hunt Groups - Packet
Data Termination Equipment Backup	Call Redirection - Packet
Call Denial On Line or Hunt Group	(To be determined)
Service Code Denial On Line or Hunt Group	(To be determined)
Preselection for Data Services	Preselection for Data Services
Reverse Charge Acceptance - Packet	Reverse Charge Acceptance - Packet
Make Busy Key	Make Busy Key
Forwarded Call Information	Message Desk (SMDI)
Network Forwarded Call Information	Message Desk - Expanded (SMDI-E)

(M)

(N)

(N)

Material on this page previously appeared on Original Page 6-12.

(This page filed under Transmittal No. 365)

ACCESS SERVICE

6. Switched Access Service (Cont'd)

(M)

6.1 General (Cont'd)

6.1.1 Switched Access Service Arrangements and Manner of Provision
(Cont'd)

(A) Switched Access Service Arrangements (Cont'd)

UNIFORM ONA SERVICE NAME CROSS REFERENCE

The following matches The Telephone Company's Basic Service Element (BSE) names to the industry standard feature names for each BSE.

<u>PACIFIC BELL</u>	<u>UNIFORM ONA SERVICE NAME</u>
Activate Message Waiting Indicator - Audible	Message Waiting Indicator - Activation (Audible)
Activate Message Waiting Indicator - Visual	Message Waiting Indicator - Activation (Visual)

(M)

Material appearing on this page previously appeared on Original Page 6-12.

(This page filed under Transmittal No. 365)

ACCESS SERVICE

6. Switched Access Service (Cont'd)6.1 General (Cont'd)6.1.1 Switched Access Service Arrangements and Manner of Provision
(Cont'd)(B) Switched Transport Service Arrangements

Switched Transport permits a one-way or two-way voice frequency transmission path composed of facilities determined by the Telephone Company which permit the transport of calls in the originating direction and in the terminating direction though not simultaneously.

Switched Transport is comprised of various facilities, connections, features and functions. The Switched Transport rate category is composed of Entrance Facilities, Direct Trunked Transport and Tandem Switched Transport. The Tandem Switched Transport rate elements are described in Section 6.1.3(A)(3). A Multiplexing charge will also apply when facilities of one capacity are connected to facilities of another capacity. (C)
(C)
(C)

Rate elements for Switched Transport are defined in 6.7.1 following.

Rates and nonrecurring charges for those rate elements are located in 6.8.2 following.

(This page filed under Transmittal No. 371)

ACCESS SERVICE

6. Switched Access Service (Cont'd)6.1 General (Cont'd)6.1.1 Switched Access Service Arrangements and Manner of Provision
(Cont'd)(B) Switched Transport Service Arrangements (Cont'd)

Rates and charges for these elements and the optional features available are set forth in 6.8 following.

Switched Transport is ordered under the Access Order provisions set forth in Section 5 (Ordering Options for Switched and Special Access Service). Ordering provisions as set forth in 2.4.8 (Billing of Access Service Provided by More Than One Telephone Company) will apply when more than one Exchange Telephone Company is involved in the provision of a Switched Transport facility. Following are descriptions of the available facilities, interfaces and features.

(C) Transport Channels and Multiplexing

Switched Transport is comprised of specific channel types. These connections may be either analog or digital. Analog connections are differentiated by spectrum and bandwidth; digital connections are differentiated by bit rate. Depending upon the spectrum, bandwidth or bit rate selected by the customer, multiplexing, as described following, may also be required to allow interconnection with other transport channels or to a Telephone Company switch.

When lower capacity transport is interconnected to higher capacity transport, the transport channel shall be specified by the customer.

(D)

(D)

(This page filed under Transmittal No. 371)

ACCESS SERVICE

6. Switched Access Service (Cont'd)6.1 General (Cont'd)6.1.1 Switched Access Service Arrangements and Manner of Provision
(Cont'd)(C) Transport Channels and Multiplexing (Cont'd)

Multiplexing is a chargeable optional feature of Switched transport. The customer has the option of ordering digital facilities at a DS3 level (44.736 Mbps) to a Telephone Company Hub for multiplexing to 28 channels at a DS1 level (1.544 Mbps) or at a DS1 level for multiplexing to 24 channels at a DS0/VG level (64 Kbps).

Use of Multiplexing allows customers to interconnect Entrance Facilities or EISCC of one capacity or bandwidth to Direct Trunked Facilities of a different capacity or bandwidth. Multiplexing also allows for the interconnection of Direct Trunked Facilities with end offices or access tandems requiring capacity or bandwidth different from that of the interconnecting facility. (D)
(D)

Three multiplexing alternatives, DS1 to Voice Grade (VG) Option 1, DS1 to VG Option 2 and DS3 to DS1 Option 1 Multiplexing will continue to be provided as described in 7.2.9(D) (3) (b) (e) (High Capacity Service), following. Option 2 pertains to Network Reconfiguration Service. (T)
(T)

When ordering, the customer will specify the desired multiplexing hub or Network Reconfiguration Hub selected from the National Exchange Carrier Association, Inc. (NECA) Tariff F.C.C. No. 4. (T)
(T)

Shared Use as set forth in Section 7.4.8 (Shared Use Analog Digital High Capacity and SONET Ring and Access Services⁽¹⁾) following does not apply to Switched transport. (N)

Multiplexing can be applied to a Switched Access Entrance Facility or Direct Trunked transport.

⁽¹⁾ Effective 01/03/06, SONET Ring and Access Service is limited to existing customers at existing locations except where spare capacity exists; customers may add additional locations on existing rings. New SONET ring services will be provided via Dedicated SONET Ring Service.

(This page filed under Transmittal No. 371)

ACCESS SERVICE

6. Switched Access Service (Cont'd)

6.1 General (Cont'd)

6.1.1 Switched Access Service Arrangements and Manner of Provision
(Cont'd)

(D) Fiber AdvantagesmService

Fiber Advantagesm DS3 and DS3x3 Month-to-Month and for DS3, DS3x3, an DS3x12 Rate Stability Payment Plans Rates and Charges are set forth in Section 6.8.2 following. Regulations that apply to this Service are set forth in Section 7.4.11 following. Minimum Periods for Fiber Advantagesm DS3, DS3x3 and DS 3x12 service apply as set forth in Section 5.2.6 (A).

(D)

(This page filed under Transmittal No. 371)

Issued: September 6, 2007

Effective: September 21, 2007

Four AT&T Plaza, Dallas, Texas 75202

ACCESS SERVICE

6. Switched Access Service (Cont'd)

6.1 General (Cont'd)

6.1.1 Switched Access Service Arrangements and Manner of Provision
(Cont'd)

Material previously on this page now appears on Original Page 6-5.1

(This page filed under Transmittal No. 365)

Issued: September 6, 2007

Effective: August 28, 2007

Four AT&T Plaza, Dallas, Texas 75202

ACCESS SERVICE

6. Switched Access Service (Cont'd)

6.1 General (Cont'd)

6.1.1 Switched Access Service Arrangements and Manner of Provision (Cont'd)

Material previously on this page now appears on Original Pages 6-5.2 and 6-5.3

(This page filed under Transmittal No. 365)

Issued: August 13, 2007

Effective: August 28, 2007

Four AT&T Plaza, Dallas, Texas 75202

ACCESS SERVICE

6. Switched Access Service (Cont'd)6.1 General (Cont'd)6.1.1 Switched Access Service Arrangements and Manner of Provision
(Cont'd)

(T)

(E) Manner of Provision

(T)

Switched Access is furnished in either quantities of lines or trunks. ALA, DNALs and FGA are furnished on a per-line basis. FGB, ATA-950, ATA-101XXXX and DID are provided on a per-trunk basis. FGD is furnished on a per-trunk basis. Trunks and lines are differentiated by type and directionality of traffic.

(D)

(1) Traffic Types

There are six major traffic types. These are: Originating, Terminating, Directory Assistance, Operator Services, Public Switched Digital Service (PSDS), and 64 CCC. Originating traffic type represents access capacity within a LATA for carrying traffic from the end user to the customer; Terminating traffic type represents access capacity within a LATA for carrying traffic from the customer to the end user; Directory Assistance traffic type represents access capacity within a LATA for carrying Directory Assistance traffic from the customer to a Directory Assistance Location; and Operator Services traffic type represents access capacity within a LATA for carrying Operator Services traffic to or from the customer, to or from the Operator Services System (OSS) location. Public Switched Digital Service (PSDS) Access traffic type represents access capability within a LATA for carrying digital traffic at speeds up to 56Kbps between the customer and the customer's end users. 64 CCC traffic type represents access capability within a LATA for carrying digital traffic at speeds up to 64 Kbps between the customer and the customer's end users.

(This page filed under Transmittal No. 371)

ACCESS SERVICE

6. Switched Access Service (Cont'd)6.1 General (Cont'd)6.1.1 Switched Access Service Arrangements and Manner of Provision
(Cont'd)(E) Manner of Provision (Cont'd)(1) Traffic Types (Cont'd)

When ordering capacity for Switched Access, the customer must at a minimum specify such access capacity in terms of Originating traffic type or Terminating traffic type or PSDS Access Traffic type. PSDS Access is available with ATA-101XXXX and FGD only. Directory Assistance traffic type is used for ordering Directory Assistance Access Service as set forth in 9.2 following. When ordering capacity for 500, 8yy or 900 Access Service, the customer must specify that the traffic type is Originating.

Because some customers will wish to further segregate their originating ATA-101XXXX, FGD or 8yy Access Service traffic into separate trunk groups, Originating traffic type is further categorized into Domestic, 500, 8yy, 900, Operator, and IDDD. Domestic traffic type (D) represents access capacity for carrying only domestic traffic other than 500, 8yy, 900, and Operator traffic; (D) IDDD traffic type represents access capacity for carrying only international traffic; and, 500, 8yy, 900, and Operator traffic type represents access capacity for (D) carrying only 500, 8yy, 900, and Operator traffic (D) respectively. When ordering such types of access, the customer must specify Domestic, 500, 8yy, 900, Operator, (D) or IDDD traffic types.

For Switched Access Services, the customer at a minimum, shall specify on the customer's order for service, the Switched Transport facilities to be provided (i.e., Entrance Facility, EISCC, Direct Trunked Transport or Tandem Switched Transport). When specifying the Switched Transport facilities to be provided, the customer must indicate if the facilities to be provided are existing (i.e. spare transmission paths) or are new.

(This page filed under Transmittal No. 550)

ACCESS SERVICE

6. Switched Access Service (Cont'd)

6.1 General (Cont'd)

6.1.1 Switched Access Service Arrangements and Manner of Provision
(Cont'd)

(E) Manner of Provision (Cont'd)

(T)

(2) Design and Traffic Routing of Switched Access Service

For Switched Access Service, the customer desired line or trunk directionality and/or traffic routing of the Switched Access Service between the customer's premises and the entry switch are specified on the customer's order for service.

(This page filed under Transmittal No. 361)

Issued: July 26, 2007

Effective: August 10, 2007

Four AT&T Plaza, Dallas, Texas 75202

ACCESS SERVICE

6. Switched Access Service (Cont'd)

6.1 General (Cont'd)

6.1.1 Switched Access Service Arrangements and Manner of Provision
(Cont'd)

(E) Manner of Provision (Cont'd)

(T)

(2) Design and Traffic Routing of Switched Access Service

For FGB and ATA-950 the customer may order the optional feature Customer Specification of Switched Transport Termination.

(3) Determination of Number of Transmission Paths

For Switched Access Service, which is ordered on a per line or per trunk basis, the customer specifies the number of transmission paths in the order for service. Each transmission path is one line or one trunk.

(C)

(This page filed under Transmittal No. 361)

ACCESS SERVICE

6. Switched Access Service (Cont'd)6.1 General (Cont'd)6.1.1 Switched Access Service Arrangements and Manner of Provision
(Cont'd)(E) Manner of Provision (Cont'd)

- (4) For FGD or ATA-101XXXX Switched Access Service with the CCSAC optional feature, i.e. out of band signaling, as described in 6.1.3(A) (5) (d), an SS7 Signaling Connection is required between the Telephone Company designated STP or Facility Signaling Point of Interconnection (FSPOI) and the customer's SPOI. When ordering the CCSAC optional feature, the customer shall specify that all traffic be equipped with out of band signaling. All rate elements set forth in 6.8.10 following apply to each SS7 Signaling Connection ordered. (C)

(5) Determination of Number of Dedicated Trunk Ports at an End Office or Access Tandem (C)

For digital switches, a Dedicated Trunk Port will be provided for each trunk.

(6) Feature Groups and Access Arrangements Cannot be Mixed in a Service Group

During the feature group transition period as set forth in the F.C.C. Order 89-79 adopted June 13, 1991 (see 6.1 preceding) customers may not mix access service at the group level to an end office or tandem. All access service must be ordered and will be provisioned similarly either as feature group service or access arrangements and cannot be mixed. However, customers may order individual circuits either as feature group or access arrangements during the transition period.

(7) Outbound Messaging Application

Outbound Messaging Application may only be used with the Outbound Messaging Application Customer's provision of services to subscribers, and may only be used in conjunction with SS7 as described above.

(This page filed under Transmittal No. 437)

ACCESS SERVICE

6. Switched Access Service (Cont'd)6.1 General (Cont'd)6.1.1 Switched Access Service Arrangements and Manner of Provision
(Cont'd)(F) Consolidation of STPs

(N)

When the Telephone Company consolidates its Common Channel Signaling (CCS) Network to reduce its number of STP pairs, customer changes in SS7 Signaling Connection Service and translations will be required.

The Telephone Company will establish schedules for any consolidation, and will work cooperatively with existing customers to establish dates by which necessary changes in facilities and translations will be completed. However, all of an existing customer's SS7 Signaling Connection Service in a LATA must be connected to the new serving arrangement, or disconnected no later than the date established by the Telephone Company for the consolidation.

In order to avoid duplicate charges for DNALs being rehomed, customers who move DNALs will need to place "add" and "disconnect" orders with the same Due Date. The Connecting Facility Assignment (CFA) on the "add" order must be the same as the one on the "disconnect" order for customers who order new links to the FSPOI.

The conversion to the consolidated architecture may require existing customers to use duplicate DNALs and STP ports at the time of conversion to assure continuity of service. Where needed, such redundancy will include the customer's existing SS7 Signaling Connection Service as well as the new SS7 Signaling Connection Service between the customer and the new STP. However, a customer may have SS7 Signaling Connection Service under both the existing arrangement and the new arrangement pursuant only to the conversion schedule established by the Telephone Company. Existing facilities no longer required after all of a customer's facilities have been converted must be disconnected within 60 days of the completion of such conversion. Requests from existing customers for augmentation of existing capacity in a LATA will be converted to the new serving arrangement in accordance with the Telephone Company's conversion schedule. Otherwise, requests for new service will be connected to the new serving arrangement regardless of when ordered.

(N)

(This page filed under Transmittal No. 437)

ACCESS SERVICE

6. Switched Access Service (Cont'd)

6.1 General (Cont'd)

6.1.1 Switched Access Service Arrangements and Manner of Provision
(Cont'd)

(F) Consolidation of STPs (Cont'd)

(N)

Recurring and nonrecurring charge credits will apply to the installation of new SS7 Signaling Connection Service associated with the Telephone Company's STP consolidation as follows: Recurring charge credits will apply for new DNALs and STP ports provided by the Telephone Company for the period of time beginning with the installation of the new connections until the earlier of 1) the disconnection of the first pair or quad of existing connections which has traffic being converted to the new arrangement or, 2) 60 days following the completion of the conversion. Both nonrecurring and recurring charge credits will apply to any new SS7 Signaling Connection Service that is required by the consolidation of traffic from other LATAs for the period of time beginning with the installation of the new SS7 Signaling Connection Service until the earlier of 1) the disconnection of the first pair or quad of existing connections that have traffic being converted to the new connections or, 2) four months after installation of the new connections.

Due to billing system constraints, all recurring and nonrecurring charges will be billed, but appropriate credits will be applied to the customer's bill after the associated existing facilities are disconnected.

(N)

(This page filed under Transmittal No. 437)

ACCESS SERVICE

6. Switched Access Service (Cont'd)

6.1 General (Cont'd)

6.1.2

6.1.3 Rate Categories

There are three rate categories which apply to Access Arrangements and Feature Groups Services:

- Switched Transport (described in 6.1.3(A) following)
- Local Switching (described in 6.1.3(B) following)
- Common Line (described in Sections 3 and 4 preceding)

In addition to the rate categories, there is an Information Surcharge that applies to all Switched Access Services. The description and application of this charge is set forth in 6.7.17, following.

(D)
(D)
(D)

(This page filed under Transmittal No. 371)

ACCESS SERVICE

6. Switched Access Service (Cont'd)

6.1 General (Cont'd)

6.1.3 Rate Categories (Cont'd)

The following diagram depicts a generic view of the components of Switched Access Service and the manner in which the components are combined to provide a complete access service.

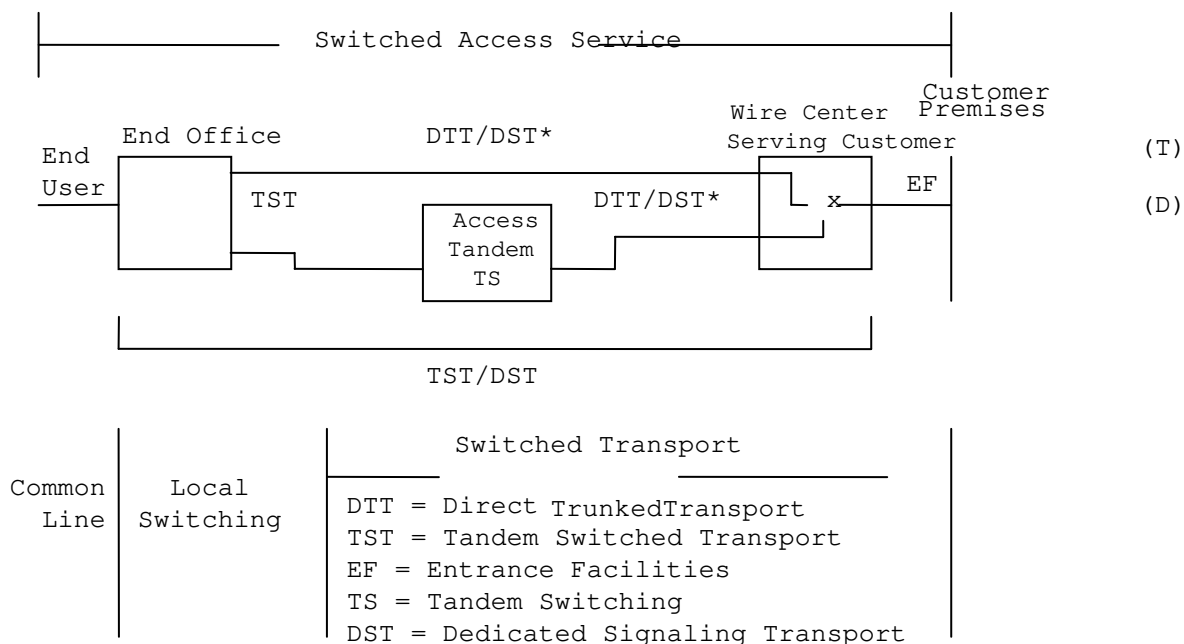

* Option as defined in Transport Application, 6.7.1(D) (9) following

LS - Local Switching

CL - Common Line

Common Line access is provided under Sections 3 (Carrier Common Line Access Service) and 4 (End User Access Service) preceding.

(This page filed under Transmittal No. 371)

ACCESS SERVICE

6. Switched Access Service (Cont'd)

6.1 General (Cont'd)

6.1.3 Rate Categories (Cont'd)

(A) Switched Transport

Switched Transport elements are defined as follows:

(1) Entrance Facility

Entrance Facility is defined as the dedicated facility (T)
between the customer's premises and the serving wire
center where the customer would normally obtain local
dial tone. The Entrance Facility rate is a non-distance
sensitive flat monthly recurring charge based on (C)
capacity. The Entrance Facility may be ordered with an (C)
analog or digital interface. The interface groups are (T)
defined in 6.1.3(A) (4) following.

Switched Access Entrance Facility rates and charges are
set forth in 6.8.2.

(This page filed under Transmittal No. 361)

ACCESS SERVICE

6. Switched Access Service (Cont'd)6.1 General (Cont'd)6.1.3 Rate Categories (Cont'd)(A) Switched Transport (Cont'd)(2) Direct Trunked Transport

Direct Trunked Transport is defined as the dedicated facility between the customer's Serving Wire Center and an access tandem, hub or end office where the customer's originating and/or terminating traffic is switched or between a hub and an access tandem or end office. Direct Trunked Transport is a distance sensitive mileage rate element as set forth in 6.8.2 following.

(T)

The Direct Trunked Transport mileage rate is calculated on the airline distance between the serving wire center associated with a customer designated premise and the access tandem, hub or end office switch or between a hub and an access tandem or end office. To determine the rate, compute the mileage using the V&H coordinates method, as set forth in the NECA Tariff F.C.C. No. 4. Exceptions to the mileage measurement rules are set forth in 6.7.13 following.

(This page filed under Transmittal No. 361)

Issued: July 26, 2007

Effective: August 10, 2007

Four AT&T Plaza, Dallas, Texas 75202

ACCESS SERVICE

6. Switched Access Service (Cont'd)6.1 General (Cont'd)6.1.3 Rate Categories (Cont'd)(A) Switched Transport (Cont'd)(3) Tandem Switched Transport

Tandem Switched Transport is provided as five sub-elements:

- Tandem-Switched Transmission/Common Transport
- Host Remote Transmission
- Tandem Switching
- Dedicated Tandem Trunk Port
- Tandem End Office Multiplexing

(This page filed under Transmittal No. 1)

Issued: April 27, 2000

Effective: May 12, 2000

Four AT&T Plaza, Dallas, Texas 75202

ACCESS SERVICE

6. Switched Access Service (Cont'd)6.1 General (Cont'd)6.1.3 Rate Categories (Cont'd)(A) Switched Transport (Cont'd)(3) Tandem Switched Transport (Cont'd)(a) Tandem Switched Transmission/Common Transport

Tandem Switched Transmission/Common Transport has two rates: a per access minute of use rate and a per access minute of use per mile rate. The per access minute of use rate applies to the non-distance sensitive portion of the Tandem Switched Transport for the termination of both ends of the facility. The per access minute of use per mile rate applies to the distance sensitive portion of the Tandem Switched Transport facility. When the mileage for Tandem Switched Transmission/Common Transport is zero, these rates will not apply.

The per access minute of use and a per access minute of use per mile rate also applies to interoffice links that are provided for the common use of all customers but which are not switched through an access tandem. The Telephone Company will identify this application of Tandem Switched Transmission as Common Transport.

Mileage measurement is calculated as the airline (N)
mileage between the end office and the access tandem (N)
as computed using the V&H coordinates method, as set (N)
forth in NECA Tariff F.C.C. No. 4. (N)

(This page filed under Transmittal No. 371)

Issued: September 6, 2007

Effective: September 22, 2007

Four AT&T Plaza, Dallas, Texas 75202

ACCESS SERVICE

6. Switched Access Service (Cont'd)

6.1 General (Cont'd)

6.1.3 Rate Categories (Cont'd)

(A) Switched Transport (Cont'd)

(3) Tandem Switched Transport (Cont'd)

(a) Tandem Switched Transmission/Common Transport
(Cont'd)

Tandem Switched Transport provides the shared transport, i.e., not dedicated to a single customer, between the access tandem and the end offices that subtend the tandem. Tandem Switched Transport is provided at the rates and charges as set forth in 6.8.2 following. To calculate the Tandem Switched Transmission Termination rate (as specified in Section 6.8.2), the customer's total tandem access minutes will be multiplied by the rate per access minute of use to determine the charge. To determine the Tandem Switched Transmission Facility mileage rate, the customer's total tandem access minutes will be multiplied by total Miles (as determined in 6.7.13, following) and the rate per access minute of use per Mile (as specified in 6.8.2, following) to determine the charge. Both rate elements are applied to the customer's total tandem access minutes to develop this Tandem Switched Transport charge, e.g.:

$$\text{Tandem Switched Transport Charge per MOU} = (A) + (B \times X)$$

Where A = Tandem Switched Transmission Termination rate

B = Tandem Switched Transmission Facility rate

X = Transport Mileage

(T)
(T)
(T)
(N)
(N)
(N)
(N)
(C)
(C)
(C)
(C)
(C)
(D)
(D)
(D)

Material previously appearing on this page now appears on Original Page 6-24.1.

(This page filed under Transmittal No. 371)

ACCESS SERVICE

6. Switched Access Service (Cont'd)

6.1 General (Cont'd)

6.1.3 Rate Categories (Cont'd)

(A) Switched Transport (Cont'd)

(3) Tandem Switched Transport (Cont'd)

(b) Host Remote Transmission

The Host Remote Transmission sub element provides for certain interoffice links that are provided for the common use of all customers between a host office and a remote switching system or remote switch where the call originates or terminates. The Host Remote Transmission rates apply to all the customer's access minutes that originate from, or terminate to, a remote switching system or module. When both Tandem Switched Transmission and Host Remote Transmission are applicable, mileage is measured separately, as set forth in 6.7.13 Host-Remote, following.

(N)
|
(N)
|
(M)
|
(M)
(N)
(N)
(N)
(M)
(M)
(N)
(N)

Material on this page previously appeared on Original Page 6-24.

(This page filed under Transmittal No. 371)

ACCESS SERVICE

6. Switched Access Service (Cont'd)

6.1 General (Cont'd)

6.1.3 Rate Categories (Cont'd)

(A) Switched Transport (Cont'd)

(T)

(3) Tandem Switched Transport (Cont'd)

(c) Tandem Switching

Tandem switching provides for the function of switching traffic from the customer's Direct Trunked Transport access tandem trunks through the access tandem to the Tandem Switched Transport. (C)
(C)
(C)

The tandem switching rate for Tandem Switched Transport is a usage sensitive charge based on the originating and terminating minutes of use that route through an access tandem switch. (T)
(T)

(d) Tandem End Office Multiplexing

Tandem End Office Multiplexing provides for the multiplexing equipment functionality on the end office side of the tandem switch and for terminating FGA, ALA minutes of use between the dial tone office and the end office.

The Tandem End Office Multiplexing rate is a usage sensitive charge based on the originating and terminating minutes of use that route through an access tandem switch or for terminating FGA, ALA minutes that terminate outside the dialtone office. (N)
(N)
(N)
(N)

(e) Dedicated Tandem Trunk Port

The Dedicated Tandem Trunk Port provides for the port associated with each in service dedicated trunk terminating on the serving wire center side of the access tandem.

The Dedicated Tandem Trunk Port rate is a flat monthly recurring charge. (N)
(N)

(This page filed under Transmittal No. 371)

ACCESS SERVICE

6. Switched Access Service (Cont'd)6.1 General (Cont'd)6.1.3 Rate Categories (Cont'd)(A) Switched Transport (Cont'd)

When the customer has ordered FGD with the CCSAC optional feature, as set forth in 6.1.3(A)(5)(d) and SS7 Signaling Connections, as set forth in 6.1.3 (A)(4) following, the Telephone Company will provide SS7 out of band signaling in accordance with the technical specifications set forth in Technical Reference TR-TSV-000905.

SS7 Signaling Connections are provisioned for LIDB Service, and interconnection is supported by interconnecting STPs as described in TR-TSV-000905 and PUB-L-780023-PB/NB.

When the customer has ordered Feature Group D with the 64 CCC optional feature, as set forth in 6.1.3(A)(5)(e), the Telephone Company will provide 64 CCC in accordance with the technical specifications set forth in TR-NWT-000938 and TR-TSV-000962.

(This page filed under Transmittal No. 1)

ACCESS SERVICE

6. Switched Access Service (Cont'd)6.1 General (Cont'd)6.1.3 Rate Categories (Cont'd)(A) Switched Transport (Cont'd)(4) Interface Groups

Five Interface Groups are provided for terminating the Switched Transport at the customer's premises. Each Interface Group provides a specified premises interface (e.g., two-wire, four-wire, DS1, etc.). Where transmission facilities permit, the individual transmission path between the customer's premises and the first point of switching may at the option of the customer be provided with optional features as set forth in (5) and (6) following.

As a result of the customer's access order and the type of Telephone Company transport facilities serving the customer's premises, the need for signaling conversions or two-wire to four-wire conversions, or the need to terminate digital or high frequency facilities in channel bank equipment may require that Telephone Company equipment be placed at the customer's premises. For example, if a voice frequency interface is ordered by the customer and the Telephone Company facilities serving the customer's premises are digital, then Telephone Company channel bank equipment must be placed at the customer's premises in order to provide the voice frequency interface ordered by the customer.

Interface Group 1 is provided with Type C Transmission Specifications, and Interface Groups 2, 5, 6 and 9 are provided with Type A or B Transmission Specifications, depending on the type of service and whether the Switched Access Service is routed directly or through an access tandem. All Interface Groups are provided with Data Transmission Parameters. Descriptions of the various Interface Groups are set forth following; more detailed descriptions are set forth in Technical Reference TR-NPL-000334.

(This page filed under Transmittal No. 1)

ACCESS SERVICE

6. Switched Access Service (Cont'd)

6.1 General (Cont'd)

6.1.3 Rate Categories (Cont'd)

(A) Switched Transport (Cont'd)

(4) Interface Groups (Cont'd)

- (a) When PSDS Access is ordered in conjunction with ATA-101XXXX or FGD, it requires the use of a dedicated trunk group equipped with Interface Group 6 or 9.

This service allows a customer to establish a connection between the customer's premises and an end user's premises over facilities capable of transmitting digital data at 56 Kbps. Technical Publication TR-NWT-000334 provides compatibility and interface requirements for using the PSDS Access optional features.

(N)

- (b) The CCSAC optional feature is available only with FGD that is provisioned using Interface Groups 6 or 9. The 64 CCC optional feature is available only with FGD with CCSAC. Feature Group D trunks are provided using Interface Groups 1, 2, 6 and 9. Technical Publication TR-TSY-000905 and PUB-L-780023-PB/NB provide the technical requirements for CCSAC and the SS7 signaling connection. Technical Publications TR-NWT-000938 and TR-TSV-000962 provide the additional technical and SS7 protocol requirements for 64 CCC.

(N)

(N)

(D)

Each Interface Group has premises interface codes available as a function of the Telephone Company switch supervisory signaling and Feature Group or Access Arrangement. A complete list of these codes can be found in Technical Reference TR-NWT-000334.

(This page filed under Transmittal No. 371)

ACCESS SERVICE

6. Switched Access Service (Cont'd)

6.1 General (Cont'd)

6.1.3 Rate Categories (Cont'd)

(A) Switched Transport (Cont'd)

(4) Interface Groups (Cont'd)

<u>Int. Group</u>	<u>USOC</u>	<u>Transmission</u>	<u>Feature Group Availability</u>	<u>Standard Signaling Arrangements</u>	
1	TPP1X	2-wire voice frequency	ALA,FGA ATA-950,FGB (ATA-101XXXX FGB,D,ATA-950,ATA-101XXXX and FGD only available if directly trunked) Not available in association with ATA-950,FGB,ATA-101XXXX or D when 1st point of switching provides only 4-wire termination.	Loop Supervisory ALA,FGA - loop start or ground start ATA-101XXXX,FGD - Reverse Battery Signaling; for 2-way calling, E&M signaling	(D) (D)
2	TPP2X	4-wire voice frequency	ALA,FGA,FGB,ATA-950,FGD,ATA-101XXXX	Loop supervisory signaling ALA,FGA - Loop start or ground start ATA-950,FGB,D,ATA-101XXXX - Reverse battery; for 2-way calling, E&M signaling	(D) (D)

(This page filed under Transmittal No. 371)

ACCESS SERVICE

6. Switched Access Service (Cont'd)

6.1 General (Cont'd)

6.1.3 Rate Categories (Cont'd)

(A) Switched Transport (Cont'd)

(4) Interface Groups (Cont'd)

<u>Int. Group</u>	<u>USOC</u>	<u>Transmission</u>	<u>Feature Group Availability</u>	<u>Standard Signaling Arrangements</u>
5	TPP5X	Master-group level analog transmission (channelizing capability of up to 600 lines or trunks)	Feature Groups only	Individual transmission path SF supervisory signaling

(C)
(C)

(This page filed under Transmittal No. 361)

ACCESS SERVICE

6. Switched Access Service (Cont'd)

6.1 General (Cont'd)

6.1.3 Rate Categories (Cont'd)

(A) Switched Transport (Cont'd)

(4) Interface Groups (Cont'd)

<u>Int. Group</u>	<u>USOC</u>	<u>Transmission</u>	<u>Feature Group Availability</u>	<u>Standard Signaling Arrangements</u>	
6	TPP6X	DS1 level digital Telephone transmission the (1.544 Mbps channelizing capability of up to 24 lines supervisory or trunks)	All Feature Groups and Access Arrangements	With digital carrier terminations, the Company will provide at 1st point of switching DS1 signal in D3/D4 format; individual-transmission path bit-stream	(C)
	SL7	DS0-A Circuit	FGD with Common Channel Signaling Access Capability or SS7 Signaling Line Identifica- tion Data Base Service or 64 Clear Channel Capability	For SS7 out of band signaling the Telephone Company will provide an Connection at the DS0-A level provisioned on a DS1 facility.	(C)

(This page filed under Transmittal No. 361)

ACCESS SERVICE

6. Switched Access Service (Cont'd)

6.1 General (Cont'd)

6.1.3 Rate Categories (Cont'd)

(A) Switched Transport (Cont'd)

(4) Interface Groups (Cont'd)

<u>Int. Group</u>	<u>USOC</u>	<u>Transmission</u>	<u>Feature Group Availability</u>	<u>Standard Signaling Arrangements</u>	
9	TPP9X	DS-3 level digital transmission	All Feature Groups and Access Arrangements	With digital carrier terminations, the Company will provide at 1st point of switching DS1 signal in D3/D4 format; individual-transmission path bit-stream signaling	(C) (C)
Telephone		(44.736 Mbps, channelizing capability of up to 672 lines or trunks)			
the					
supervisory					

(This page filed under Transmittal No. 361)

ACCESS SERVICE

6. Switched Access Service (Cont'd)

6.1 General (Cont'd)

6.1.3 Rate Categories (Cont'd)

(A) Switched Transport (Cont'd)

(D)

(D)

Material previously appearing on this page now appears on Original Page 6-47.1.

(This page filed under Transmittal No. 371)

Issued: September 6, 2007

Effective: September 22, 2007

Four AT&T Plaza, Dallas, Texas 75202

ACCESS SERVICE

6. Switched Access Service (Cont'd)

6.1 General (Cont'd)

6.1.3 Rate Categories (Cont'd)

(A) Switched Transport (Cont'd)

(5) Nonchargeable Optional Features

Where transmission facilities permit, the Telephone Company will, at the option of the customer, provide the following optional features in association with Switched Transport. The optional features are provided as set forth in following.

(a) Supervisory Signaling

Where the transmission parameters permit, and where signaling conversion is required by the customer to meet its signaling capability, the customer may order an optional supervisory signaling arrangement for each transmission option path provided. The types of supervisory signaling available are described in Technical Reference TR-NPL-000334.

<u>Interface Groups 1 and 2</u>	<u>FID</u>
DX Supervisory Signaling	NCI ++DX+
E&M Type 1	NCI ++EA+
E&M Type II	NCI ++EB+
E&M Type III	NCI ++EC+
<u>Interface Group 2</u>	<u>FID</u>
SF Supervisory Signaling	NCI ++SF+
Tandem Supervisory Signaling	NCI ++EX+

Interface Groups 5, 6 and 9

Individual transmission path SF Supervisory Signaling in Telephone Company central offices where the entry switch provides an analog, i.e., non-digital interface to the transport termination and a portion of the facility between the analog entry switch and the customer's premises is analog. These optional supervisory signaling arrangements are not available in combination with the CCSAC optional feature, as described in 6.1.3 (A), (5), (d) following.

(This page filed under Transmittal No. 1)

ACCESS SERVICE

6. Switched Access Service (Cont'd)6.1 General (Cont'd)6.1.3 Rate Categories (Cont'd)(A) Switched Transport (Cont'd)(5) Nonchargeable Optional Features (Cont'd)(b) Customer Specified Entry Switch Receive Level (TLV)

This feature allows the customer to specify the receive transmission level at the first point of switching. The range of transmission levels which may be specified is described in Technical Reference TR-NTW-000334. This feature is available with Interface Groups 2, 5, 6 and 9 for FGA and FGB and Interface Groups 2, 6 and 9 for ALA and ATA-950.

(c) Customer Specification of Switched Transport Termination (NL S+T+)

This option allows the customer to specify, for ATA-950 and FGB routed directly to an end office or access tandem, a four-wire termination of the Switched Transport at the entry switch in lieu of a Telephone Company selected two-wire termination. This option is available only when the ATA-950 or FGB arrangement is provided with Type B Transmission Specifications.

(This page filed under Transmittal No. 1)

ACCESS SERVICE

6. Switched Access Service (Cont'd)6.1 General (Cont'd)6.1.3 Rate Categories (Cont'd)(A) Switched Transport (Cont'd)(5) Nonchargeable Optional Features (Cont'd)(d) Common Channel Signaling Access Capability (CCSAC)

This optional feature allows the customer to exchange signaling for call set-up via SS7 out of band signaling. This option is available only with FGD or ATA-101XXXX. This option requires the establishment of a SS7 Signaling Connection between the customer's signaling point of interface (SPOI) and the Telephone Company's Signaling Transfer Point (STP), as set forth in 6.1.3(A), (4) preceding. This option is available with incidental interlata service as amended by the Telecommunications Act of 1996, Section 271 (g) and defined in PUB L - 780023 - PB/NB. Rates and Charges for the SS7 Signaling Connection are set forth in 6.8.10 following. Information concerning incidental interlata service is set forth in Section 18 following.

Each SS7 Signaling Connection provides for digital transmission at a speed of 56 Kbps. The connection to the Telephone Company STP can be made from either the customer's Signaling Point (SP) which requires two 56 Kbps circuits or from the customer's STP which requires four 56 Kbps circuits.

(This page filed under Transmittal No. 1)

ACCESS SERVICE

6. Switched Access Service (Cont'd)6.1 General (Cont'd)6.1.3 Rate Categories (Cont'd)(A) Switched Transport (Cont'd)(5) Nonchargeable Optional Features (Cont'd)(e) 64 Clear Channel Capability (CCC)

This option is available only with FGD with the CCSAC optional feature as set forth in 6.1.3(A)(6)(d), preceding.

Clear Channel Capability (CCC) is designated as a new traffic type and requires the establishment of a new minimum period as described in 5.2.6 (E), preceding.

64 CCC will be provided in connection with FGD with CCSAC where appropriate Telephone Company equipment and other facilities exist, as specified in the NECA Tariff F.C.C. No. 4. Technical Reference TR-NWT-000938 provides the technical specifications for 64 CCC. The SS7 protocol requirements for 64 CCC are specified in TR-TSV-000962.

(This page filed under Transmittal No. 1)

Issued: April 27, 2000

Effective: May 12, 2000

Four AT&T Plaza, Dallas, Texas 75202

ACCESS SERVICE

6. Switched Access Service (Cont'd)6.1 General (Cont'd)6.1.3 Rate Categories (Cont'd)(A) Switched Transport (Cont'd)(5) Nonchargeable Optional Features (Cont'd)(f) Tandem Signaling

Signaling information necessary for tandem switching (D)
will be provided from end offices. This option is (C)
available with either MF or SS7 signaling. Tandem
Signaling will provide the CIC and OZZ in
association with MF signaling. TNS parameter will
be provided with SS7 signaling.

Tandem signaling is an originating offering
utilizing FGD Switched Access Service. It will be (C)
provided on one-way originating FGD trunks from end
offices to a Tandem Switching Provider's (TSP) point
of termination.

TSPs can terminate switched access traffic to
Telephone Company end offices or access tandems over
any currently tariffed Feature Group Service. The
customer ordering the terminating Feature Group
service will be the customer of record and billed
the terminating usage. This customer may be either
a TSP or a customer of the TSP.

If the TSP is the customer of record and requests
the Telephone Company to separately bill the traffic
usage to it's multiple customers, the TSP must
provide to the Telephone Company billing tapes in a
format to be mutually agreed upon by the Telephone
Company and the TSP. These tapes must be provided
in a standard EMI format and received by the
Telephone Company within a mutually agreed upon
timeframe.

(This page filed under Transmittal No. 517)

ACCESS SERVICE

6. Switched Access Service (Cont'd)6.1 General (Cont'd)6.1.3 Rate Categories (Cont'd)(A) Switched Transport (Cont'd)(5) Nonchargeable Optional Features (Cont'd)(f) Tandem Signaling (Cont'd)

Technical specifications for Tandem Signaling are as set forth in Technical Reference GR-3334-CORE.

A maximum of 4 OZZ codes (MF) or circuit codes (SS7) per CIC per end office will be provided. The Telephone Company will control and assign the OZZ codes to the customer ordering this feature. FGD trunks with Tandem Signaling may not be alternately routed to the Telephone Company's access tandem.

(This page filed under Transmittal No. 1)

Issued: April 27, 2000

Effective: May 12, 2000

Four AT&T Plaza, Dallas, Texas 75202

ACCESS SERVICE

6. Switched Access Service (Cont'd)

6.1 General (Cont'd)

6.1.3 Rate Categories (Cont'd)

(A) Switched Transport (Cont'd)

(6) Chargeable Optional Features

(a) Reserved for Future Use

(T)

(D)

(D)

(This page filed under Transmittal No. 550)

Issued: January 24, 2017

Effective: February 8, 2017

675 W. Peachtree St. NW, Atlanta, GA 30308

ACCESS SERVICE

6. Switched Access Service (Cont'd)6.1 General (Cont'd)6.1.3 Rate Categories (Cont'd)(A) Switched Transport (Cont'd)(6) Chargeable Optional Features (Cont'd) (T)(b) Multiplexing

This option allows the customer to convert a DS3 (44.736 Mbps) to 28 DS1 channels or a DS1 (1.544 Mbps) to 24 DS0/VG channels (64 Kbps) for both Option 1 and Option 2.

(C)

A charge is specified in 6.8.2 following per multiplexing arrangement.

(c) Carrier Identification Parameter (CIP)

Technical specifications for Carrier Identification Parameter (CIP) are set forth in Technical References GR-394-CORE and GR-905-CORE.

Carrier Identification Parameter is an optional feature which identifies and transmits the CIC within the SS7 out of band call set up, known as the initial address message (IAM), associated with each call sent to subscribing customers. CIP is only available with originating FGD Switched Access Service from suitably equipped SS7 out of band signaling end offices and access tandems. When CIP is provided, the switch will transmit the 3 or 4 digit CIC of the presubscribed line or the CIC selected when the end user places a call using 101XXXX dialing. CIP is provided per trunk group at a monthly recurring rate as specified in 6.8.2(K) (3).

(d) Outbound Messaging Application

Outbound Messaging Application provides the ability to have a signal sent from the Telephone Company's SS7 Network to the Outbound Messaging Application Customer. This service functions with an Inter-Stored Program Control Switch (Inter-SPCS) Feature, which provides the ability to receive and respond to a signal sent by the Telephone Company's SS7 Network. Additional information on Inter-SPCS Feature can be found in Telcordia Technical Publication GR-866-CORE.

(This page filed under Transmittal No. 371)

ACCESS SERVICE

6. Switched Access Service (Cont'd)

6.1 General (Cont'd)

6.1.3 Rate Categories (Cont'd)

(A) Switched Transport (Cont'd)

(6) Chargeable Optional Features (Cont'd)

(d) Outbound Messaging Application (Cont'd)

The Outbound Messaging Application service is provided on a per point code, per LATA basis, and in conjunction with the Telephone Company's SS7 STP Access Service for use with telephone numbers for which the Outbound Messaging Application signal is generated.

(N)

(N)

(This page filed under Transmittal No. 285)

Issued: April 26, 2006

Effective: April 27, 2006

Four AT&T Plaza, Dallas, Texas 75202

ACCESS SERVICE

6. Switched Access Service (Cont'd)

6.1 General (Cont'd)

6.1.3 Rate Categories (Cont'd)

(A) Switched Transport (Cont'd)

(7) Dedicated Network Access Link

Description: A Dedicated Network Access Link (DNAL) provides a dedicated analog data channel from the customer's premises and a designated central office which contains the specific network features required by the customer. The DNAL is used to transmit network information or network control information from the customer to the network, or to deliver network control information from the network to the customer's premises. DNALs may or may not be provisioned using a Facility Signaling Point of Interconnection (FSPOI).

When a DNAL used to provide SS7 Signaling Connection Service is provisioned using a FSPOI, the DNAL is ordered from the customer's designated premises to a Telephone Company-designated STP or FSPOI. FSPOIs are deployed only in LATAs where the Telephone Company has removed an STP pair through consolidation and rehomeing.

STP and FSPOI locations are set forth in the National Exchange Carrier Association, Inc. Tariff F.C.C. No. 4.

When the customer requests a DNAL to a Telephone Company STP that resides in a LATA other than the LATA of customer's designated premises, the customer is responsible for obtaining the interLATA facilities required to provision such DNAL.

(N)

(N)

Some material previously on this page now appears on Original Page 6-42.1

(This page filed under Transmittal No. 437)

ACCESS SERVICE

6. Switched Access Service (Cont'd)

6.1 General (Cont'd)

6.1.3 Rate Categories (Cont'd)

(A) Switched Transport (Cont'd)

(7) Dedicated Network Access Link (Cont'd)

- (a) Service Types: There are two types of DNAL and each (M)
has its own characteristics and are subdivided into
one or more of the following:
 - Transmission specifications
 - Bandwidth
 - Optional features and functions

Type 1 DNAL is defined in Technical Reference TR-TSY-000335 as Voice Grade 2 and Type 2 is Voice Grade 10. Customers can order basic service and select from a list of available features, functions and channel interfaces, that they desire to meet specific communications requirements. The Type 2 DNAL has the following optional features and functions available:

- Conditioning
 - C-Type
 - Improved Attenuation Distortion
 - Improved Envelope Delay Distortion
 - Improved Termination
 - Data Capability

(M)

Material on this page previously appeared on Original Page 6-42

(This page filed under Transmittal No. 437)

ACCESS SERVICE

6. Switched Access Service (Cont'd)6.1 General (Cont'd)6.1.3 Rate Categories (Cont'd)(A) Switched Transport (Cont'd)(7) Dedicated Network Access Link (Cont'd)

(b) There are three basic rate categories which apply to DNALs:

- Transport Terminations
- Transport Mileage
- Optional Features and Functions

(I) Transport Termination

The Transport Termination rate category provides for a communication path between the customer designated premises and the serving wire center of that premises and from the serving wire center to the designated central office which contains the specific network features required by the customer.

(II) Transport Mileage

The mileage to be used to determine the monthly rate for the Transport Mileage is calculated on the airline distance between the serving wire center associated with a customer designated premises and the Telephone Company central office where the service terminates. The serving wire center associated with a customer designated premises is the serving wire center from which the customer designated premises would normally obtain dial tone. Transport Mileage rate has two rates: a fixed rate and a per mile rate. To determine the rate to be billed, compute the mileage using the V&H Coordinates Method, as set forth in the NECA Tariff F.C.C. No. 4.

(This page filed under Transmittal No. 1)

ACCESS SERVICE

6. Switched Access Service (Cont'd)

6.1 General (Cont'd)

6.1.3 Rate Categories (Cont'd)

(A) Switched Transport (Cont'd)

(7) Dedicated Network Access Link (Cont'd)

(b) (Cont'd)

(II) Transport Mileage (Cont'd)

When a DNAL used to provide SS7 Signaling Connection Service is provisioned using a FSPOI, the Mileage rate category provides for the transmission facilities between the serving wire center associated with a customer-designated premises and the Telephone Company-designated Central Office FSPOI equipment necessary to terminate the DNAL.

If ordering to a FSPOI, a fixed monthly rate applies, per mileage band, from the serving wire center associated with a customer-designated premises and the Telephone Company-designated Central Office FSPOI equipment.

If ordering to a FSPOI, a monthly rate per mile applies to each airline mile between the serving wire center associated with a customer-designated premises and the Telephone Company-designated Central Office FSPOI equipment.

(N)

(N)

(This page filed under Transmittal No. 437)

ACCESS SERVICE

6. Switched Access Service (Cont'd)6.1 General (Cont'd)6.1.3 Rate Categories (Cont'd)(A) Switched Transport (Cont'd)(7) Dedicated Network Access Link (Cont'd)

- (b) There are three basic rate categories which apply to DNALs: (Cont'd)

(III) Optional Features and Functions

This rate category provides for optional features and functions which may be added to a DNAL service to improve its quality or utility to meet specific communications requirements. These are not necessarily identifiable with specific equipment, but rather represent the end result in terms of performance characteristics which may be obtained by using various combinations of equipment. Although the equipment necessary to perform a specified function may be installed at various locations along the path of the service, it will be charged for as a single rate element.

There are five optional features and functions which apply to DNALs. They are listed below.

Conditioning

Conditioning provides more specific transmission characteristics for DNAL service. There are three types of conditioning available: C-Type, Improved Attenuation Distortion, and Improved Envelope Delay Distortion.

- C-Type conditioning is provided for the additional control of attenuation distortion and envelope delay distortion on an analog data service. The attenuation distortion and envelope delay distortion specifications are set forth in TR-TSY-000335.

(This page filed under Transmittal No. 1)

ACCESS SERVICE

6. Switched Access Service (Cont'd)6.1 General (Cont'd)6.1.3 Rate Categories (Cont'd)(A) Switched Transport (Cont'd)(7) Dedicated Network Access Link (Cont'd)

- (b) There are three basic rate categories which apply to DNALs: (Cont'd

(III) Optional Features and Functions (Cont'd)Conditioning (Cont'd)

- Improved attenuation distortion is provided for supplementary control of attenuation distortion. Improved attenuation distortion specifications are set forth in Technical Reference TR-TSY-000335.
- Improved Envelope Delay Distortion is provided for supplementary control of envelope delay distortion. Improved envelope delay distortion specifications are set forth in Technical Reference TR-TSY-000335.

Improved Termination

- Improved termination provides for the ordered impedance (nominally 600 ohms at 1 kHz), a wide range of transmission level points and simplex reversal, if specified. Improved termination is applicable on effective four-wire transmission at the four-wire point of termination. Telephone Company equipment is required at the customer's premises where this option is ordered. The improved termination parameters are set forth in Technical Reference TR-TSY-000335.

(This page filed under Transmittal No. 1)

ACCESS SERVICE

6. Switched Access Service (Cont'd)6.1 General (Cont'd)6.1.3 Rate Categories (Cont'd)(A) Switched Transport (Cont'd)(7) Dedicated Network Access Link (Cont'd)

- (b) There are three basic rate categories which apply to DNALs: (Cont'd

(III) Optional Features and Functions (Cont'd)Improved Return Loss

- Improved return loss provides for more stringent Echo Control specification. Improved return loss is applicable on effective two-wire transmission at the two-wire point of termination. The transmission path must be four-wire at one point of termination (POT) and two-wire at the other point of termination. Placement of Telephone Company equipment may be required at the customer's premises with the two-wire POT. Improved return loss specifications are set forth in Technical Reference TR-TSY-000335.

Data Capability

- Data capability provides transmission characteristics suitable for data communications. Specifically, data capability provides for the control of Signal to C-Notched Noise Ratio and intermodulation distortion. When a service equipped with data capability is used for voice communications, the quality of the voice transmission may not be satisfactory.

(This page filed under Transmittal No. 1)

ACCESS SERVICE

6. Switched Access Service (Cont'd)6.1 General (Cont'd)6.1.3 Rate Categories (Cont'd)(A) Switched Transport (Cont'd)(7) Dedicated Network Access Link (Cont'd)

- (b) There are three basic rate categories which apply to DNALs: (Cont'd

(III) Optional Features and Functions (Cont'd)Signaling Capability

- Signaling capability provides for the process of transferring circuit status information over a distance to control such conditions as circuit idle, circuit busy, seizure, and disconnect. Another function of signaling is station alerting and addressing when required. Generally, the signaling used on DNAL service is in-band and is furnished by the end user. In-band signaling utilizes tones within the frequency spectrum of the channel to perform the various signaling functions necessary. Signaling specifications are set forth in Technical Reference TR-TSY-000335.

(c) Technical Specifications

DNAL service provides voice frequency transmission capability in the normal frequency range of 300 to 3000 Hz and may be terminated two-wire or four-wire. The technical specifications for these parameters (except for dropouts, gain hits, and phase hits) are set forth in Technical Reference TR-TSY-000335. The technical specifications for dropouts, phase hits, and gain hits are set forth in Technical Reference PUB 41004, Table 4.

(This page filed under Transmittal No. 1)

ACCESS SERVICE

6. Switched Access Service (Cont'd)

6.1 General (Cont'd)

6.1.3 Rate Categories (Cont'd)

(A) Switched Transport (Cont'd)

(8) Zone Pricing

Switched Access Entrance Facility - VG, DS1 (1.544 Mbps) or DS3 (44.736 Mbps); Direct Trunked Transport - VG, DS1 (1.544 Mbps) or DS3 (44.736 Mbps); Multiplexing; Tandem Switched Transmission; Host Remote Transmission; and Tandem Switching rate elements are divided into three pricing zones. The pricing zone is determined by the wire center that is identified in the NECA Tariff F.C.C. No. 4. When the rate element is mileage sensitive, e.g., Direct Trunked Transport, Tandem Switched Transmission or Host Remote Transmission, and where the wire centers are in different pricing zones, then the higher pricing zone applies for both the fixed and the per mile components. The rate elements included in zone pricing are as follows:

(a) Entrance Facility

The rate for each Entrance Facility - VG, DS1 (1.544 Mbps) or DS3 (44.736 Mbps), is determined by the wire center location of the serving wire center.

(b) Direct Trunked Transport

Direct Trunked Transport - VG, DS1 (1.544 Mbps) or DS3 (44.736 Mbps), price zone(s) is determined by the wire center locations of the customer's serving wire center, hub(s), end office or access tandem.

(c) Multiplexing

The rates for multiplexing will be determined by the wire center location of the multiplexing arrangement.

(M)

(M)

(C)

(C)

(M)

(T)

(T)

(T)

(M)

(T)

(T)

(T)

(M)

(C)

(M)

Material on this page previously appeared on Original Page 6-33.

(This page filed under Transmittal No. 371)

ACCESS SERVICE

6. Switched Access Service (Cont'd)

(N)

6.1 General (Cont'd)

6.1.3 Rate Categories (Cont'd)

(A) Switched Transport (Cont'd)

(8) Zone Pricing (Cont'd)

(d) Tandem Switched Transmission

The Tandem Switched Transmission price zone is determined by the wire center locations of the access tandem and the end office.

(e) Host Remote Transmission

The Host Remote Transmission price zone is determined by the wire center locations of the Host and the Remote.

(f) Tandem Switching

The rate for Tandem Switching is determined by the wire center location of the access tandem.

(N)

(This page filed under Transmittal No. 371)

ACCESS SERVICE

6. Switched Access Service (Cont'd)6.1 General (Cont'd)6.1.3 Rate Categories (Cont'd)(B) Local Switching

This rate category provides for (1) local end office switching, i.e., the common switching functions associated with the various Switched Access Service arrangements, (2) the termination of Switched Transport at end offices, (3) the termination of common lines and WATS Access Lines at end offices and (4) intercept functions, i.e., the termination of certain calls at a Telephone Company intercept recording, (5) the Dedicated End Office Port which provides for each dedicated line or trunk terminating in the end office port, and (6) the Shared End Office Trunk Port which provides for the use of the shared end office trunk ports for termination of common transport trunks for tandem routed traffic. (D)

This Category includes usage sensitive rates and both chargeable and nonchargeable optional features.

(a) Usage Sensitive Rates

The usage sensitive rates are applied on a per minute of use basis and are divided into the following categories:

- (i) LS1 provides local switching functions for FGA and FGB, except for FGA and FGB used to terminate traffic to a WATS Access Line (WAL).
- (ii) LS1A provides local switching functions for the ALA and ATA-950 except when the ALA or ATA-950 is used to terminate traffic to a WATS Access Line (WAL).
- (iii) LS2 provides local switching functions for FGA and FGB used to terminate traffic to a WAL, FGD and 8yy or 900 Access Service. Where end offices are appropriately equipped, international dialing may also be provided as a capability of LS2, i.e., the capability of switching international calls with service prefix and address codes having more digits than can be switched through a standard FGD end office.

(This page filed under Transmittal No. 573)

ACCESS SERVICE

6. Switched Access Service (Cont'd)

6.1 General (Cont'd)

6.1.3 Rate Categories (Cont'd)

(B) Local Switching (Cont'd)

(a) Usage Sensitive Rates (Cont'd)

(T)

(iv) LS2D provides local switching functions for ATA-950 and ALA used to terminate traffic to a WAL, ATA-101XXXX, 8yy Access Service and 900 Access Service. Where end offices are appropriately equipped, international dialing may also be provided as a capability of LS2D, i.e., the capability of switching international calls with service prefix and address codes having more digits than can be switched through a standard ATA-101XXXX end office.

(D)

(T)

(v) Shared End Office Trunk Port provides for the trunk port termination for common trunks in the end office which are used for carrying traffic to and from the access tandem.

(N)

(N)

(N)

(N)

The application of these rates is set forth in following.

Rates for Local Switching are set forth in 6.8 following.

(b) Optional Features

Various Common Switching, Transport Termination and WATS Access Line Termination optional features are available and are described in 6.3. following.

(c) Monthly Recurring Rates

Dedicated End Office Trunk Ports provide the termination for lines or trunks dedicated to a customer that terminate in an end office and are charged on a per month basis.

(N)

(N)

(N)

(N)

(N)

(This page filed under Transmittal No. 371)

ACCESS SERVICE

6. Switched Access Service (Cont'd)6.1 General (Cont'd)6.1.6 Acceptance Testing

At no additional charge, the Telephone Company will, at the customer's request, cooperatively test, at the time of installation, the following parameters: loss, C-Message noise, C-notched noise, 3-tone slope, d.c. continuity and operational signaling. When the Switched Transport is provided with Interface Groups 2, 5, 6 and 9, and the Transport Termination is two-wire (i.e., there is a four-wire to two-wire conversion in Switched Transport), balance parameters (equal level echo path loss) may also be tested.

Entrance Facility or Direct Trunked Transport acceptance tests will include tests for the parameters applicable to the service as specified in the order for service.

6.1.7 CCSAC and 64 CCC Testing Requirements

For FGD with the CCSAC optional feature, network compatibility and other operational tests will be performed cooperatively by the Telephone Company and the customer. These tests are as specified in the PUB-L-780023-PB/NB and Technical Reference TR-TSY-000905. These tests must be successfully completed prior to providing the CCSAC optional feature.

For FGD with the 64 CCC optional feature additional network compatibility and other operational tests will be performed to verify compliance with specifications in Technical References TR-NWT-000938 and TR-TSV-000962.

(This page filed under Transmittal No. 1)

ACCESS SERVICE

6. Switched Access Service (Cont'd)6.2 Provision and Description of Switched Access Service

Switched Access Service is provided in two different arrangements. The two arrangements are Direct Trunked Transport to an end office (direct routed) and Direct Trunked Transport to an access tandem (tandem routed). Entrance Facilities are provisioned for either arrangement unless the customer has Expanded Interconnection Services (see Section 16). The provision of each Switched Access Service requires Switched Transport facilities and the appropriate End Office functions. There are various optional features available with the Feature Groups and Access Arrangements. The Switched Transport, Common Switching and Transport Termination optional features are available at all Telephone Company end office switches, unless stated otherwise. In addition, a WATS Access Line Service as described in 7.2.3 following may, at the option of the customer, be provided for use with Switched Access Service. WATS Access Line Termination optional features are available in end offices designated as WATS Serving Offices.

(C)
(C)
(C)
(C)
(C)

There are three specific voice transmission specifications (i.e., Types A, B and C) that have been identified for the provision of Switched Access Service.

Switched Access Service is arranged for either originating, terminating or two-way calling. Originating calling permits the delivery of calls from an end user premises to the customer's premises. Terminating calling permits the delivery of calls from the customer's premises to an end user premises. Two-way calling permits the delivery of calls in both directions, but not simultaneously.

(T)
(T)
(T)

Following are detailed descriptions of the available Switched Access Services. Each Switched Access Service is described in terms of its specific physical characteristics and calling patterns, the transmission specifications with which it is provided, the optional features available for use with it and the standard testing capabilities.

(This page filed under Transmittal No. 371)

ACCESS SERVICE

6. Switched Access Service (Cont'd)6.2 Provision and Description of Switched Access Service (Cont'd)6.2.1 Feature Group A (FGA)(A) Description

FGA, which is available to all customers, provides line-side access to Telephone Company end office switches with an associated seven digit local telephone number for the customer's use in originating and terminating communications to an Interexchange Carrier's Interstate Service or a customer-provided Interstate communications capability. The customer must specify the IXC to which the FGA Service is connected or, in the alternative, specify the means by which the FGA access communication is transported to another state

- (1) FGA is provided in connection with Telephone Company electronic and electromechanical end offices. At the option of the customer, FGA is provided on a single or multiple-line-group basis and is arranged for originating calling only, terminating calling only, or two-way calling.
- (2) At the first point of switching, FGA provides a line-side termination arranged for either ground-start or loop-start supervisory signaling. The type of signaling is at the option of the customer.
- (3) Within the selected LATA, the customer may request the first point of switching at which the line-side termination is to be provided. If Telephone Company facilities or measurement capabilities are not available to accommodate such a request, the Telephone Company will select the first point of switching.

(This page filed under Transmittal No. 1)

ACCESS SERVICE

6. Switched Access Service (Cont'd)6.2 Provision and Description of Switched Access Service (Cont'd)6.2.1 Feature Group A (FGA) (Cont'd)(A) Description (Cont'd)

- (4) A seven-digit local telephone number assigned by the Telephone Company is provided for access to FGA switching in the originating direction. The seven-digit local telephone number will be associated with the selected end office switch and is of the form NXX-XXXX. If the customer requests a specific seven digit telephone number that is not currently assigned, and the Telephone Company can, with reasonable effort, comply with that request, the requested number will be assigned to the customer.
- (5) In the terminating direction, FGA switching is arranged with dial-tone start-dial signaling; and may, at the option of the customer, be arranged for dial-pulse or dual-tone multi-frequency address signaling, subject to availability of equipment at the first point of switching. When FGA switching is provided in a hunt group or uniform call distribution arrangement, all FGA switching will be arranged for the same type of address signaling.

(This page filed under Transmittal No. 1)

ACCESS SERVICE

6. Switched Access Service (Cont'd)6.2 Provision and Description of Switched Access Service (Cont'd)6.2.1 Feature Group A (FGA) (Cont'd)(A) Description (Cont'd)

- (6) No address signaling is provided by the Telephone Company when FGA Switching is used in the originating direction. Address signaling in such cases, if required by the customer, must be provided by the customer's end user using inband-tone signaling techniques. Such inband-tone address signals will not be regenerated by the Telephone Company and will be subject to the ordinary transmission capabilities of the Switched Transport provided.
- (7) When used in the terminating direction, FGA switching may access valid NXXs in the LATA, local operator service (0- and 0+), Directory Assistance, emergency reporting service (911 where available), exchange telephone repair (611 where available), time or weather announcement services of the Telephone Company, community information services of an information service provider, and other customer's services (by dialing the appropriate digits). Charges for FGA terminating calls requiring operator assistance or calls to 611 or 911 will only apply where sufficient call details are available. Additional non-access charges will also be billed for: (1) an operator surcharge, as set forth in the local exchange tariffs, for local operator assistance (0-and 0+) calls; (2) calls to certain community information services, for which rates are applicable under Telephone Company exchange service tariffs, e.g., 976 (DIAL-IT) Network Services and; (3) calls from a FGA line to another customer's service in accordance with that customer's applicable service rates when the Telephone Company performs the billing function for that customer.

(This page filed under Transmittal No. 1)

ACCESS SERVICE

6. Switched Access Service (Cont'd)6.2 Provision and Description of Switched Access Service (Cont'd)6.2.1 Feature Group A (FGA) (Cont'd)(A) Description (Cont'd)

(7) (Cont'd)

For FGA calls to Directory Assistance, Switched Access Service usage rates will not apply. Instead, FGA calls to this service are subject to the Directory Assistance Service per call rates as set forth in 9.6 (A) and (B) following.

- (8) When a FGA switching arrangement for an individual customer (a single line or entire hunt group) is discontinued at an end office, an intercept announcement is provided. This arrangement provides, for a limited period of time, an announcement that the service associated with the number dialed has been disconnected.

(B) Optional Features(1) Common Switching Optional Features

- (a) Hunt Group Arrangement
- (b) Uniform Call Distribution Arrangement
- (c) Nonhunting Number for Use with Hunt Group Arrangement or Uniform Call Distribution Arrangement
- (d) Call Denial
- (e) Service Code Denial
- (f) Band Advance Arrangement for Use with WATS Access Line Service
- (g) Hunt Group Arrangement for Use with WATS Access Line Service
- (h) Uniform Call Distribution Arrangement for Use with WATS Access Line Service
- (I) Nonhunting Number for Use with Hunt Group Arrangement or Uniform Call Distribution Arrangement for Use with WATS Access Line Service

(This page filed under Transmittal No. 1)

ACCESS SERVICE

6. Switched Access Service (Cont'd)6.2 Provision and Description of Switched Access Service (Cont'd)6.2.1 Feature Group A (FGA) (Cont'd)(B) Optional Features (Cont'd)(2) Transport Termination Optional Features

- (a) Two-way operation with dial-pulse address signaling and loop-start supervisory signaling
- (b) Two-way operation with dial-pulse address signaling and ground-start supervisory signaling
- (c) Two-way operation with dual-tone multifrequency address signaling and loop-start supervisory signaling
- (d) Two-way operation with dual-tone multifrequency address signaling and ground-start supervisory signaling
- (e) Terminating operation with dial-pulse address signaling and loop-start supervisory signaling
- (f) Terminating operation with dial-pulse address signaling and ground-start supervisory signaling
- (g) Terminating operation with dual-tone multifrequency address signaling and loop-start supervisory signaling
- (h) Terminating operation with dual-tone multifrequency address signaling and ground-start supervisory signaling
- (I) Originating operation with loop-start supervisory signaling
- (j) Originating operation with ground-start supervisory signaling

(3) Switched Transport Optional Features

- (a) Supervisory Signaling (as set forth in 6.1.3(A) (5) (a) preceding)
- (b) Customer-Specified Entry Switch Receive Level

(This page filed under Transmittal No. 1)

ACCESS SERVICE

6. Switched Access Service (Cont'd)6.2 Provision and Description of Switched Access Service (Cont'd)6.2.1 Feature Group A (FGA) (Cont'd)(B) Optional Features (Cont'd)

(4) Certain other features which may be available in connection with FGA are provided under the Telephone Company's local and/or general exchange service tariffs. These include:

- (a) Comstar Features
- (b) Bill Number Screening
- (c) IntraLATA Extensions
- (d) Remote Call Forwarding
- (e) Information Services Call Blocking

(C)

(D) Testing Capabilities

FGA is provided, in the terminating direction where equipment is available, with seven-digit access to balance (100 type) test line and milliwatt (102 type) test line. In addition to the tests described in 6.1.6 preceding which are included with the installation of service, additional Cooperative Acceptance Testing and Nonscheduled Testing are available for FGA as set forth in 13.3.5 following.

(This page filed under Transmittal No. 1)

ACCESS SERVICE

6. Switched Access Service (Cont'd)

6.2 Provision and Description of Switched Access Service (Cont'd)

6.2.2 Feature Group B (FGB)

(A) Description

FGB, which is available to all customers, provides trunk-side access to Telephone Company end office switches with an associated uniform 950-XXXX access code for the customer's use in originating and terminating communications to an IXC's interstate service or a customer-provided interstate communications capability. The customer must specify the IXC to which the FGB Service is connected or, in the alternative, specify the means by which FGB Access communication is transported to another state.

- (1) When provided via Telephone Company designated access tandem switches, FGB switching is provided at Telephone Company end office switches. (D)
- When directly routed to an end office (i.e., provided without the use of an access tandem switch), FGB switching is provided at appropriately equipped Telephone Company end office switches. (D)

(This page filed under Transmittal No. 371)

ACCESS SERVICE

6. Switched Access Service (Cont'd)6.2 Provision and Description of Switched Access Service (Cont'd)6.2.2 Feature Group B (FGB) (Cont'd)

(T)

(A) Description (Cont'd)

- (2) FGB is provided as trunk-side switching using either end-office or access-tandem-switch trunk equipment. The switch trunk equipment is provided with wink-start start-pulsing signals and answer and disconnect supervisory signaling.
- (3) FGB switching is provided with multifrequency address signaling in both the originating and terminating directions. Except for FGB switching provided with the automatic number identification (ANI) or rotary-dial station signaling arrangements as set forth in 6.3 following, any other address signaling in the originating direction, if required by the customer, must be provided by the customer's end user using inband-tone signaling techniques. Such inband-tone address signals will not be regenerated by the Telephone Company and will be subject to the ordinary transmission capabilities of the Switched Transport provided.
- (4) The access code for FGB switching is a uniform access code. The form of the uniform access code is 950-XXXX for carriers. These uniform access codes will be the assigned access numbers of all FGB Switched Access Service provided to the customer by the Telephone Company.
- (5) When used in the terminating direction, FGB switching may access valid NXXs in the LATA, time or weather announcement services of the Telephone Company, community information services of an information service provider and other customer's services (by dialing the appropriate digits). When directly routed to an end office, only those valid NXX codes served by that end office may be accessed. When routed through an access tandem, only those valid NXX codes served by end offices subtending the access tandem may be accessed unless LATA-wide terminating access optional switching is selected, as set forth in 6.3.1(v), following.

(N)
(N)

(This page filed under Transmittal No. 371)

ACCESS SERVICE

6. Switched Access Service (Cont'd)6.2 Provision and Description of Switched Access Service (Cont'd)6.2.2 Feature Group B (FGB) (Cont'd)(A) Description (Cont'd)

(5) (Cont'd)

The customer will also be billed additional non-access charges for calls to certain community information services for which rates are applicable under Telephone Company exchange service tariffs, e.g., 976 (DIAL-IT) Network Service. Additionally, non-access charges will also be billed for calls connecting to a non-Telephone Company service in accordance with that customer's applicable service rates when the Telephone Company performs the billing function for that customer. Calls in the terminating direction will not be completed to 950-XXXX access codes, local operator assistance (0-and 0+), Directory Assistance (411), service codes 611 and 911 or 101XXXX access codes. Calls will be completed to Directory Assistance (NPA-555-1212 or 555-1212) when FGB Switching is combined with Directory Assistance Switching. The combination of FGB Switched Access Service with Directory Assistance Service is provided as set forth in Section 9, following. FGB may not be switched, in the terminating direction, to Switched Access Service FGB and FGD.

(Z)

(D)

(6) The Telephone Company will establish a trunk group or groups for the customer at end office switches or access tandem switches where FGB switching is provided. When required by technical limitations, a separate trunk group will be established for each type of FGB switching arrangement provided. Different types of FGB or other switching arrangements may be combined in a single trunk group at the option of the Telephone Company.

(7) When all FGB switching arrangements are discontinued at an end office and/or in a LATA, an intercept announcement is provided. This arrangement provides, for a limited period of time, an announcement that the service associated with the number dialed has been disconnected.

(This page filed under Transmittal No. 371)

ACCESS SERVICE

6. Switched Access Service (Cont'd)6.2 Provision and Description of Switched Access Service (Cont'd)6.2.2 Feature Group B (FGB) (Cont'd)(A) Description (Cont'd)

- (8) Bill Number Screening is provided under the Telephone Company's local and/or general exchange service tariffs.

(B) Optional Features(1) Common Switching Optional Features

- (a) Automatic Number Identification (ANI)
- (b) Up-to-10-Digit Outpulsing of Access Digits to customer (C)
- (c) Alternate Traffic Routing
- (d) Band Advance Arrangement for Use with WATS Access Line Service
- (e) Hunt Group Arrangement for Use with WATS Access Line Service
- (f) Uniform Call Distribution Arrangement for Use with WATS Access Line Service
- (g) Nonhunting Number for Use with Hunt Group Arrangement or Uniform Call Distribution Arrangement for Use with WATS Access Line Service
- (h) LATA-wide Terminating Access

(2) Transport Termination Optional Features

- (a) Rotary-Dial Station Signaling

(3) Switched Transport Optional Features

- (a) Customer-Specification of Switched Transport Termination
- (b) Supervisory Signaling (as set forth in 6.1.3(A) (5) (a) preceding)
- (c) Customer-Specified Entry Switch Receive Level

(4) WATS Access Line Termination Optional Feature

- (a) E & M Supervisory Signaling

(This page filed under Transmittal No. 371)

ACCESS SERVICE

6. Switched Access Service (Cont'd)

6.2 Provision and Description of Switched Access Service (Cont'd)

6.2.2 Feature Group B (FGB) (Cont'd)

(C) Testing Capabilities

(T)

FGB is provided, in the terminating direction where equipment is available, with seven-digit access (or ten-digit access if required with LATA-wide terminating access) to balance (100 type) test line, milliwatt (102 type) test line, nonsynchronous or synchronous test line, automatic transmission measuring (105 type) test line, digital circuit loopback (108 type) test line, loop-around test line, short-circuit test line and open-circuit test line. In addition to the tests described in 6.1.6 preceding which are included with the installation of service, additional Cooperative Acceptance Testing, Automatic Scheduled Testing, Cooperative Scheduled Testing, Manual Scheduled Testing and Non-Scheduled Testing are available as set forth in 13.3.5 (Testing Services) following.

(C)
(C)

6.2.3

(D)

(D)

(This page filed under Transmittal No. 371)

ACCESS SERVICE

6. Switched Access Service (Cont'd)

6.2 Provision and Description of Switched Access Service (Cont'd)

6.2.3

(D)

(D)

(This page filed under Transmittal No. 371)

Issued: September 6, 2007

Effective: September 22, 2007

Four AT&T Plaza, Dallas, Texas 75202

ACCESS SERVICE

6. Switched Access Service (Cont'd)

6.2 Provision and Description of Switched Access Service (Cont'd)

6.2.3

(D)

(D)

(This page filed under Transmittal No. 371)

Issued: September 6, 2007

Effective: September 22, 2007

Four AT&T Plaza, Dallas, Texas 75202

ACCESS SERVICE

6. Switched Access Service (Cont'd)

6.2 Provision and Description of Switched Access Service (Cont'd)

6.2.3

(D)

(D)

(This page filed under Transmittal No. 371)

Issued: September 6, 2007

Effective: September 22, 2007

Four AT&T Plaza, Dallas, Texas 75202

ACCESS SERVICE

6. Switched Access Service (Cont'd)

6.2 Provision and Description of Switched Access Service (Cont'd)

6.2.3

(D)

(D)

(This page filed under Transmittal No. 371)

Issued: September 6, 2007

Effective: September 22, 2007

Four AT&T Plaza, Dallas, Texas 75202

ACCESS SERVICE

6. Switched Access Service (Cont'd)

6.2 Provision and Description of Switched Access Service (Cont'd)

6.2.3

(D)

(D)

(This page filed under Transmittal No. 371)

Issued: September 6, 2007

Effective: September 22, 2007

Four AT&T Plaza, Dallas, Texas 75202

ACCESS SERVICE

6. Switched Access Service (Cont'd)

6.2 Provision and Description of Switched Access Service (Cont'd)

6.2.3

(D)

(D)

6.2.4 Feature Group D (FGD)

(A) Description

FGD Access which is available to all customers, provides trunk side access to Telephone Company end office switches with an associated 101XXXX access code for the customer's use in originating and terminating communications. For FGD with the CCSAC option, out of band signaling is provided through Telephone Company designated STPs.

(1) FGD is provided at Telephone Company end office switches whether routed directly or via Telephone Company designated access tandem switches.

(D)

(D)

(2) FGD is provided as trunk-side switching through the use of end office or access tandem switch trunk equipment. The switch trunk equipment is provided with wink-start start-pulsing signals and answer and disconnect supervisory signaling, or without signaling when the CCSAC optional feature is specified

(This page filed under Transmittal No. 371)

ACCESS SERVICE

6. Switched Access Service (Cont'd)6.2 Provision and Description of Switched Access Service (Cont'd)6.2.4 Feature Group D (FGD) (Cont'd)(A) Description (Cont'd)

- (3) FGD switching is provided with multifrequency address or SS7 signaling. Up to 15 digits of the called party number dialed by the customer's end user using dual-tone multifrequency or dial-pulse address signals will be provided by Telephone Company equipment to the customer's premises where the Switched Access Service terminates. Such address signals will be subject to the ordinary transmission capabilities of the Switched Transport provided. (C)
- (4) When used in the terminating direction, FGD switching may access valid NXXs in the LATA, time or weather announcement services of the Telephone Company, community information services of an information service provider, and other customer's services (by dialing the appropriate codes) when such services can be reached using valid NXX codes. When directly routed to an end office, only those valid NXX codes served by that office may be accessed. When routed through an access tandem, only those valid NXX codes served by end offices subtending the access tandem may be accessed. The customer will also be billed additional non-access charges for calls to certain community information services, for which rates are applicable under Telephone Company exchange service tariffs, e.g., 976 (DIAL-IT) Network Service. Additionally, non-access charges will also be billed for calls connecting to a non-Telephone Company service in accordance with that customer's applicable service rates

(This page filed under Transmittal No. 371)

ACCESS SERVICE

6. Switched Access Service (Cont'd)6.2 Provision and Description of Switched Access Service (Cont'd)6.2.4 Feature Group D (FGD) (Cont'd)(A) Description (Cont'd)

(4) (Cont'd)

when the Telephone Company performs the billing function for that customer. Calls in the terminating direction will not be completed to 950-XXXX access codes, local operator assistance (0-and 0+), Directory Assistance (411 and 555-1212), service codes (611 and 911) and 101XXXX access codes. Calls will be completed to Directory Assistance (NPA-555-1212 or 555-1212) when FGD switching is combined with Directory Assistance switching. The combination of FGD Switched Access Service with Directory Assistance Service is provided as set forth in 9. following. FGD may not be switched, in the terminating direction, to Switched Access Service FGB or FGD.

(D)

- (5) The Telephone Company will establish a trunk group or groups for the customer at end office switches or access tandem switches where FGD switching is provided. When required by technical limitations, a separate trunk group will be established for each type of FGD switching arrangement provided. Different types of FGD or other switching arrangements may be combined in a single trunk group at the option of the Telephone Company.
- (6) The access code for FGD switching is a uniform access code of the form 101XXXX. These uniform access codes will be the assigned access numbers of all FGD access provided to the customer by the Telephone Company. No access code is required for calls to a customer over FGD Switched Access Service if the end user's telephone exchange service is arranged for presubscription to that customer, as set forth in 13.3.3 (Presubscription and Preselection) following.

(This page filed under Transmittal No. 371)

ACCESS SERVICE

6. Switched Access Service (Cont'd)6.2 Provision and Description of Switched Access Service (Cont'd)6.2.4 Feature Group D (FGD) (Cont'd)(A) Description (Cont'd)

(6) (Cont'd)

Where no access code is required, the number dialed by the customer's end user shall be a seven or ten-digit number for calls in the NANP. For international calls outside the NANP, a seven to fifteen-digit number may be dialed. The form of the numbers dialed by the customer's end user is NXX-XXXX, 0 or 1+ NXX-XXXX, NPA + NXX-XXXX, 0 or 1+ NPA + NXX-XXXX, and, when the end office is equipped for IDDD, 01+ CC + NN or 011+ CC + NN. (C)

When the 101XXXX access code is used, FGD switching also provides for dialing the digit 0 for access to the customer's operator, 911 for access to the Telephone Company's emergency reporting service, or at the customer's option, the end-of-dialing digit (#) for cut-through access to the customer's premises.

(7) FGD switching will be arranged to accept calls from telephone exchange service locations without the need for dialing 101XXXX uniform access code. Each telephone exchange service line may be marked with a presubscription code to identify which 101XXXX code its calls will be directed to for interLATA service. Presubscription codes are applied as set forth in 13.3.3 (Presubscription and Preselection) following.

(8) When the 101XXXX 1+ or 011+ sent-paid access code is dialed from a Telephone Company pay telephone to a customer that has not ordered per 6.3.2(B) or (C) following, the calls will be routed to a Telephone Company recording.

(This page filed under Transmittal No. 371)

ACCESS SERVICE

6. Switched Access Service (Cont'd)6.2 Provision and Description of Switched Access Service (Cont'd)6.2.4 Feature Group D (FGD) (Cont'd)(A) Description (Cont'd)

- (9) When a customer has had FGB access in an end office and subsequently replaces the FGB access with FGD access, at the mutual agreement of the customer and the Telephone Company, the Telephone Company will direct calls dialed by the customer's end users using the customer's previous FGB access code to the customer's FGD access service, as long as the FGB 0/1XXX access code is the same as the four (4) digit FGD 0/1XXX and only in the 0/1 bank of numbers.

When a customer has both FGB and FGD access in the same end office or separate end offices which subtend the same access tandem and chooses to route his originating FGB calls over FGD access, the Telephone Company will direct calls dialed by the customer's end users using the customer's FGB access code to the customer's FGD access service, as long as the FGB 0/1XXX access code is the same as the four (4) digit FGD 0/1XXX and only in the 0/1 bank of numbers. Such calls will be rated as FGD.

(D)

The customer must be prepared to handle normally dialed FGD calls, as well as, calls dialed with the FGB access code which requires the customer to receive additional address signaling from the end user. Such calls will be rated as FGD.

- (10) When Public Switched Digital Service (PSDS) Access is provided with FGD, the dialing pattern will be modified as follows. In the originating direction, end users at suitably equipped end user premises can activate the capability in the end office by dialing the #56 + 101XXXX + 7 or 10 digits or #56 + 1 + 7 or 10 digits when presubscribed to a participating interexchange carrier.

(This page filed under Transmittal No. 371)

ACCESS SERVICE

6. Switched Access Service (Cont'd)

6.2 Provision and Description of Switched Access Service (Cont'd)

6.2.4 Feature Group D (FGD) (Cont'd)

(A) Description (Cont'd)

(D)

(D)

(11) FGD access is available to accept 950 calls with multifrequency or CCSAC signaling. With CCSAC signaling, the customer may also order Charged Number (CN) as an additional Common Switching Optional Feature.

(T)

(12) At the option of the customer, the Tandem Signaling optional feature as described in Section 6.1.3(A) (5) (f), is available for use on one-way originating FGD trunks provisioned from end offices to a customer's point of termination.

(T)

(T)

(This page filed under Transmittal No. 550)

ACCESS SERVICE

6. Switched Access Service (Cont'd)6.2 Provision and Description of Switched Access Service (Cont'd)6.2.4 Feature Group D (FGD) (Cont'd)(B) Optional Features(1) Common Switching Optional Features

- (a) Automatic Number Identification (ANI)
- (b) Service Class Routing
- (c) Alternate Traffic Routing
- (d) Call Gapping Arrangement
- (e) Trunk Access Limitation
- (f) International Carrier Option
- (g) End Office End User Line Service Screening for Use with WATS Access Line Service
- (h) Hunt Group Arrangement for Use with WATS Access Line Service
- (I) Hunt Group Arrangement for Use with PVN Access Line Service
- (j) Uniform Call Distribution Arrangement for Use with WATS Access Line Service
- (k) Nonhunting Number for Use with Hunt Group Arrangement or Uniform Call Distribution Arrangement for WATS Access Line Service
- (l) Band Advance Arrangement for Use with WATS Access Line Service
- (m) Cut-through
- (n) Public Switched Digital Service (PSDS) Access
- (o) Calling Party Number (CPN)
- (p) Charge Number (CN)
- (q) Carrier Selection Parameter (CSP)
- (r) Access Transport Parameter (ATP)

(This page filed under Transmittal No. 1)

ACCESS SERVICE

6. Switched Access Service (Cont'd)

6.2 Provision and Description of Switched Access Service (Cont'd)

6.2.4 Feature Group D (FGD) (Cont'd)

(B) Optional Features (Cont'd)

(2) Transport Termination Optional Features

- (a) Operator Trunks - Modified Operator Services (MOS) Direct - i.e., Coin and Combined Coin and Non-Coin.
- (b) Operator Trunks - Exchange Access Operator Services System (EAOSS) - i.e., Coin 1+ and 011+ sent-paid as well as 0+, 00- and 01+ where technically feasible.

(3) Switched Transport Optional Features

- (a) Supervisory Signaling (as set forth in Section 6.1.3(A) (5) (a)). (T)
(T)
- (b) Common Channel Signaling Access Capability (CCSAC) set forth in Section 6.1.3(A) (5) (d)). (T)
(D)
(D)
- (c) 64 Clear Channel Capability (CCC) (as set forth in Section 6.1.3(A) (5) (e)). (T)
- (d) Carrier Identification Parameter (CIP) (as set forth in Section 6.1.3(A) (6) (c)). (T)

(4) WATS Access Line Termination Optional Features

- (a) E&M Supervisory Signaling
- (b) Dialed Number Identification Service

(This page filed under Transmittal No. 550)

ACCESS SERVICE

6. Switched Access Service (Cont'd)

6.2 Provision and Description of Switched Access Service (Cont'd)

6.2.4 Feature Group D (FGD) (Cont'd)

(B) Optional Features (Cont'd)

(5) Tandem Signaling Optional Feature

(a) CIC and OZZ (as set forth in 6.1.3(A) (5) (f) .

(b) TNS (as set forth in 6.1.3(A) (5) (f) .

(This page filed under Transmittal No. 1)

Issued: April 27, 2000

Effective: May 12, 2000

Four AT&T Plaza, Dallas, Texas 75202

ACCESS SERVICE

6. Switched Access Service (Cont'd)6.2 Provision and Description of Switched Access Service (Cont'd)6.2.4 Feature Group D (FGD) (Cont'd)(C) Testing Capabilities

FGD is provided, in the terminating direction where equipment is available, with seven-digit access to balance (100 type) test line, milliwatt (102 type) test line, nonsynchronous or synchronous test line, automatic transmission measuring (105 type) test line, digital circuit loopback (108 type) test line, loop-around test line, short-circuit test line and open-circuit test line. In addition to the tests described in 6.1.6 preceding which are included with the installation of service, additional Cooperative Acceptance Testing, Automatic Scheduled Testing, Cooperative Scheduled Testing, Manual Scheduled Testing, and Non-Scheduled Testing, are available for FGD as set forth in 13.3.5 (Testing Services) following.

(C)

(This page filed under Transmittal No. 371)

ACCESS SERVICE

6. Switched Access Service (Cont'd)6.2 Provision and Description of Switched Access Service (Cont'd)6.2.5 Line Information Data Base (LIDB) Service(A) General Description

LIDB Service is provided by the Telephone Company to its customers in support of alternate billing services. There are three different LIDB Services offered: LIDB Billing Validation, Originating Line Number Screening Service and Equipment Indicator Service (OLNS Service), and Preferred Validation Service. LIDB Service provides access to billing validation data which resides in the Telephone Company data base for use with alternate billing services, such as Collect Calls and Third Number Billing.⁽¹⁾ OLNS Service provides information on the type of service/equipment associated with the line originating the call. Preferred Validation Service provides for the ability to have the Telephone Company restrict LIDB information from a customers' query-originating service platforms. (N)

Customers participating in LIDB Service for purposes of obtaining LIDB Billing Validation or OLNS Service data originate queries to the LIDB from an Operator Service System (OSS) identified by an originating point code. The requested billing validation data, in the form of signaling information, is passed back from the Service Control Point (SCP) where the LIDB resides via the Telephone Company STP to the customer's designated OSS where the LIDB query originated. The LIDB system will receive and respond to American National Standards Institute Signaling System 7 protocol queries as defined in Bellcore publication TR-TSV-000905, and Pacific Bell publication PUB L-780023 PB/NB.

LIDB Billing Validation Service will provide the following functions on a per query basis:

- Determination of whether the billed line automatically rejects certain calls billed as collect or third number.⁽¹⁾ (N)
- Determination of whether the billed line is a public telephone number using the "Service or Equipment Indicator" in the LIDB.

⁽¹⁾ Effective September 13, 2016, collect calls and calls billed to a third number have been discontinued by the Telephone Company. (N)

(This page filed under Transmittal No. 544)

ACCESS SERVICE

6. Switched Access Service (Cont'd)6.2 Provision and Description of Switched Access Service (Cont'd)6.2.5 Line Information Data Base (LIDB) Service (Cont'd)(A) General Description (Cont'd)

Both aggregator and non-aggregator customers may purchase these functions separately (unbundled).

- An aggregator is defined as any person that, in the ordinary course of its operations, makes telephones available to the public or to transient users of its premises, for interstate telephone calls using a provider of operator services.
- A non-aggregator is any other business customer.

OLNS Service provides customers with access to the Telephone Company's LIDB to facilitate the completion of originating calls from working telephone numbers. In response to a properly formatted OLNS query, the Telephone Company will provide the service and equipment values associated with the originating line.

The Telephone Company will provide customer interconnection to its STP through the establishment of an SS7 Signaling Connection between the Customer's Signaling Point of Interface (SPOI) and the STP, as set forth in 6.1.3(A) (4) preceding.

(This page filed under Transmittal No. 1)

ACCESS SERVICE

6. Switched Access Service (Cont'd)6.2 Provision and Description of Switched Access Service (Cont'd)6.2.5 Line Information Data Base (LIDB) Service (Cont'd)(A) General Description (Cont'd)

OLNS (Originating Line Number Screening) Service provides customers access to the Telephone Company's LIDB to facilitate the completion of originating calls from working telephone numbers. In response to a properly formatted OLNS query, the Telephone Company will provide originating line screening information that will identify allowable originating call processing and originating billing decisions.

(D)
(D)
(D)
(D)

Preferred Validation Service is an optional service that provides customers with the ability to have the Telephone Company restrict LIDB information from such customers' query-originating service platforms. This restriction is on a per-Originating Point Code, per Account Owner, per LIDB basis. The Telephone Company provides Preferred Validation Service to customers in support of services that use LIDB Service Applications.

The Telephone Company will activate or deactivate the Preferred Validation Service upon the request of the customer. Such activation or deactivation will be within 2 business days of customer's request, unless the customer requests the service be activated or deactivated earlier than 2 days and if the Telephone Company is able to comply.

Technical specifications for Preferred Validation Service, generically known as Data Screening, can be found in the following Technical Reference Publication:

GR-3697-CORE

When a customer activates Preferred Validation Service, the Telephone Company will return Unavailable Network Resource (error code value 3) for Validation Service and Screened Response (error code value 250) for OLNS when customer's queries encounter Account Owners that the customer has identified for Preferred Validation Service.

Customers that choose to activate the Preferred Validation Service are responsible for any required inter-company notification. The Telephone Company, upon request from Account Owners in the LIDB, will identify customers that have activated the Preferred Validation Service. Customers of the Preferred Validation Service are responsible for resolving all issues associated with their use of the service.

(This page filed under Transmittal No. 371)

ACCESS SERVICE

6. Switched Access Service (Cont'd)6.2 Provision and Description of Switched Access Service (Cont'd)6.2.5 Line Information Data Base (LIDB) Service (Cont'd)(B) Undertaking of the Telephone Company

The Telephone Company will provide to the customer, upon initiation of service, or upon demand thereafter by the customer, confirmation of the billing restrictions as applied to the customer's lines.

LIDB Service will be provided on an interrogation basis, as set forth in 6.2.5(A) preceding. LIDB Service is provided on a call-by-call basis and data accessed may not be stored elsewhere for future use.

Any end user line information of the Telephone Company that is furnished, made available to, or otherwise disclosed to the customer shall remain the sole property of the Telephone Company and not reproduced for other purposes.

LIDB Service is provided subject to technical capability and successful completion of application testing.

The Telephone Company's LIDB is updated seven days a week, 24 hours per day. High priority updates, which include the disablement of a number due to fraudulent use, are completed in real time via terminal input to the LIDB Administrative System. Direct access to LIDB is also available as a backup. Normal day to day updates required to add and delete numbers, are batch processed through to LIDB at the end of each day. LIDB data accuracy is ensured by regular audits against various corporate support systems.

(This page filed under Transmittal No. 1)

ACCESS SERVICE

6. Switched Access Service (Cont'd)6.2 Provision and Description of Switched Access Service (Cont'd)6.2.5 Line Information Data Base (LIDB) Service (Cont'd)(B) Undertaking of the Telephone Company (Cont'd)

The Telephone Company monitors LIDB Billing Validation Service seven days a week, 24 hours per day, for potential fraud. Fraud detection is based on thresholding routines contained within the LIDB, and pattern analysis based on information as set forth in 6.2.5(C) following. Potential fraud detected within the LIDB application is reported to, and then aggregated by, an adjunct processor. This processor retains historical fraud patterns and a record of previous investigations. If fraud is suspected, customer contact will be attempted. If a high probability of fraud exists, the Telephone Company will disable a number for alternate billing purposes, and follow up with the customer.

Should unexpected high levels of attempts for LIDB Service occur, creating an overload in the Service Control Point (SCP), Automatic Code Gapping (AGC) will be implemented by the SCP to reduce the rate at which LIDB Service messages are processed by the SCP. AGC is applied across all attempts originating from all Networks. As LIDB Service query messages reach the SCP, a slow down process will be invoked until the congestion period has passed. During periods of extremely high service demands, incoming query messages may be discarded. When AGC is applied, a SCP to query originator message is sent to indicate that an overload condition exists.

(This page filed under Transmittal No. 1)

ACCESS SERVICE

6. Switched Access Service (Cont'd)6.2 Provision and Description of Switched Access Service (Cont'd)6.2.5 Line Information Data Base (LIDB) Service (Cont'd)(C) Obligation of the Customer

The customer shall provide a LIDB Service Percent Interstate Usage (PIU) Report in accordance with Section 2.3.14(A) (6) preceding.

- The customer will use the LIDB Services provided here under only for the purposes as described in 6.2.5(A) preceding.
- If in the Telephone Company's reasonable opinion the LIDB Service information is used by a customer contrary to the terms and conditions as described in 6.2.5(B) and (C), the Telephone Company will discontinue LIDB Service to that customer.

If the customer to LIDB Service is to offer LIDB Billing Validation Service or OLNS Service to other parties, they must provide the identity of the secondary LIDB assessor ten (10) days prior to accessing LIDB.

If service is to be changed or disconnected, sixty (60) days' written notice to the Telephone Company is required.

All direct or secondary LIDB assessors must provide both the actual calling number and the actual called number associated with the ABS call in progress for which billing number validation is being performed. This information will be safeguarded by the Telephone Company and used in the identification and analysis of potential alternate billing fraud.

(This page filed under Transmittal No. 1)

ACCESS SERVICE

6. Switched Access Service (Cont'd)6.2 Provision and Description of Switched Access Service (Cont'd)6.2.5 Line Information Data Base (LIDB) Service (Cont'd)(D) Rate Regulations(1) Description of Rates and Charges

There are two types of rates and charges that will apply to both LIDB Services. These are usage rates and nonrecurring charges. These rates and charges are applied as set forth in 6.2.5(D) (1) (a) and (b) following.

(a) Usage Rates

The usage rates for LIDB Service are applicable on a per query basis as described in Section 6.2.5 (D) (2) following and set forth in 6.8.9 following.

(b) Nonrecurring Charges

Nonrecurring charges apply for each request for establishment of an originating point code for LIDB Service. The nonrecurring charges for the establishment of LIDB Service are set forth in Section 6.8.9 following.

(2) Application of Rates and Charges

Rates and charges for LIDB Service are applied as follows

(a) LIDB Transport Charge

A per query usage rate applies to each LIDB Billing Validation query and OLNS query received at the Telephone Company Service Control Point (SCP). Charges are accumulated over a bill round and are billed to the customer on a bill period basis.

(C)

(T)

(This page filed under Transmittal No. 371)

ACCESS SERVICE

6. Switched Access Service (Cont'd)

6.2 Provision and Description of Switched Access Service (Cont'd)

6.2.5 Line Information Data Base (LIDB) Service (Cont'd)

(D) Rate Regulations (Cont'd)

(2) Application of Rates and Charges (Cont'd)

(b) LIDB Query Charge

A separate per query usage rate applies to each LIDB Billing Validation query and OLNS query received at the Telephone Company SCP. Charges are accumulated and billed to the customer on a bill period basis.

(C)

(c) LIDB Service Establishment Charge

A nonrecurring charge to be applied per originating point code, applies for the establishment of LIDB Service as specified in Section 6.2.5(D)(1) preceding.

(T)

(This page filed under Transmittal No. 371)

ACCESS SERVICE

6. Switched Access Service (Cont'd)6.2 Provision and Description of Switched Access Service (Cont'd)6.2.6 900 Access Service

900 Access Service is an originating offering utilizing trunk side Switched Access Service. The service provides a customer identification function based on the dialed 900 number at Telephone Company appropriately equipped end offices or tandem switches.

When a 1+900+NXX-XXXX call is originated by an end user, the Telephone Company will perform the customer identification function based on the dialed digits to determine the customer location to which the call is to be routed. If the call originates from an end office switch not equipped to provide the customer identification function, the call will be routed to an office at which the function is available. Once customer identification has been established, the call will be routed to the customer. Calls originating in an end office switch in which the customer has not ordered 900 Access Service will be routed to intercept. 900 calls from COIN, 0+, 0-, 1010XXX, inmate service, and hotel motel will be blocked. The customer may request unblocking of 0+ 900 calling except on inmate or other classes of service which do not allow 900 calling.

(D)

(T)

(This page filed under Transmittal No. 371)

Issued: September 6, 2007

Effective: September 22, 2007

Four AT&T Plaza, Dallas, Texas 75202

ACCESS SERVICE

6. Switched Access Service (Cont'd)

6.2 Provision and Description of Switched Access Service (Cont'd)

6.2.6 900 Access Service (Cont'd)

When 900 Access Service is provided, all such service will be provisioned in accordance with the technical characteristics available with FGD and ATA-101XXXX except when more than one tandem is employed in the transport of a 900 Access Service call. (D)

(D)
(D)
(D)
(D)
(D)

When more than one tandem is employed in the transport of a 900 Access Service call, transmission quality cannot be guaranteed.

900 Access Service originating from end offices with the customer identification function will be provided using exchange access signaling with overlap outpulsing and ten-digit ANI, or with SS7 out of band signaling when the customer has ordered the CCSAC optional feature with FGD. 900 Access Service originating from end offices without the customer identification function, will be provided using conventional signaling. On traffic using conventional signaling, the customer's facilities shall provide off-hook supervision upon receipt of the transmitted digits or answer supervision when the called party answers. (D)

900 Access Service usage measurement shall be in accordance with the regulations set forth in 6.7.8 following for FGD and ATA-101XXXX. (D)

The customer's 900 Access Service may be combined in the same trunk group arrangement with the customer's non-900 Access Service traffic or, at the request of the customer, a separate trunk group will be established for 900 Access Service.

900 Access Service will be available in every LATA.

(This page filed under Transmittal No. 371)

ACCESS SERVICE

6. Switched Access Service (Cont'd)

6.2 Provision and Description of Switched Access Service (Cont'd)

6.2.6 900 Access Service (Cont'd)

The Telephone Company will work cooperatively with the customer to implement any network management controls (e.g. call gapping and code blocking) to protect the network from traffic surges due to peaked 900 Access Services. Customer notification of peaked services is required as set forth in 6.6.1(D).

(This page filed under Transmittal No. 1)

Issued: April 27, 2000

Effective: May 12, 2000

Four AT&T Plaza, Dallas, Texas 75202

ACCESS SERVICE

6. Switched Access Service (Cont'd)6.2 Provision and Description of Switched Access Service (Cont'd)6.2.7 X.25⁽¹⁾

(C)

(A) Description

X.25 provides transport and routing of packets of digital information by concentrating them on digital transmission facilities at transmission speeds of less than or equal to 56 kilobits per second (Kbps). A packet is a continuous sequence of binary digits of information which is switched through the network as an integral unit. A packet consists of up to 512 characters of end user data plus control and error information. These characters are groups of eight binary digits and are also called octets.

The network interface provided under this tariff uses X.75 protocol, as outlined by the Consultative Committee on International Telegraphy and Telephony, a United Nations communications standards body. Access to the X.25 network may be by subscriber connections or dedicated digital facilities, as described in 6.2.7 (B). Connection and usage charges will apply and are listed in 6.8.1 Parameter options, such as packet size, throughput class negotiation, etc., are service design characteristics that are set at the initial service establishment in negotiations with the customer.

The Telephone Company will not transport packets across a LATA boundary. X.25 will be furnished only in LATAs where central offices are equipped to provide this service. Service may be unavailable or disrupted for network maintenance routines between the hours of 2 a.m. and 5 a.m. each Thursday.

(N)
(N)

(1) As of October 6, 2004, X.25 and X.75 protocols are obsolete and limited to existing installations, at existing locations, for existing customers.

(This page filed under Transmittal No. 170)

ACCESS SERVICE

6. Switched Access Service (Cont'd)6.2 Provision and Description of Switched Access Service (Cont'd)6.2.7 X.25 (Cont'd)⁽¹⁾(B) Connection to X.25

(C)

(1) Dedicated X.75 Internetwork Interface

A Dedicated X.75 Internetwork Interface is required for all customers providing internetwork data transport. It provides the capability of connecting a customer's Signaling Terminal Equipment (STE) to the X.25 switching network via a dedicated digital facility at transmission speeds of 9.6 or 56 Kbps synchronous, allowing both send and receive capability.

The STE is equipment used for internetwork packet transport to exchange packets with another packet switch through a X.75 Internetwork Interface that must meet packet network protocol interface specifications. One logical channel is included with the basic service. A logical channel is a communications channel that allows two-way simultaneous transmission of data packets through the network. No circuit capability is preassigned to a logical channel; capacity is made available as data is transmitted. Each virtual circuit utilizes only one logical channel.

The required digital facilities to the dedicated X.75 Internetwork Interface are described in Section 7.

(2) Subscriber Connections

Subscriber connections allow end users to enter the Telephone Company's X.25 network. These connections may be made by any of the following methods:

- public dial connections
- private dial connections
- dedicated analog interfaces
- dedicated digital interfaces

(N)
(N)

(1)As of October 6, 2004, X.25 and X.75 protocols are obsolete and limited to existing installations, at existing locations, for existing customers.

(This page filed under Transmittal No. 170)

ACCESS SERVICE

6. Switched Access Service (Cont'd)6.2 Provision and Description of Switched Access Service (Cont'd)6.2.7 X.25 (Cont'd)⁽¹⁾

(C)

(B) Connection to X.25 (Cont'd)(2) Subscriber Connections (Cont'd)

The subscriber initiating the call will pay all exchange-related charges. All appropriate charges listed in 6.8.1 will be billed to the X.75 customer.

(C) Optional Features

Only the following optional features are available with X.75 Internetwork Interfaces.

(1) Fast Select-Initiate is a feature which allows limited amounts of data during the call set-up phase to be sent to and received from a Data Network Address (DNA) conditioned for fast select acceptance. A DNA is a numeric character string used to identify the customer's interface within the network. Each successful fast select initiated call incurs charges for a call set-up and a minimum of two segments of data.

(2) Fast Select Acceptance is a feature which allows for the acceptance of data sent via a fast select initiate type call.

(3) Hunt Group-Internal, which occurs internally within the X.25 network, allows for a grouping of up to 30 secondary DNAs with a ten digit pilot DNA. Hunting allows the next available DNA to be seized on a call.

(4) Preselection for Data Services is a feature which allows carrier preselection data to be passed as part of the addressing and routing information within the packet.

(5) Reverse Charge Acceptance-Packet is a feature which allows packet calls and associated billing to be accepted or rejected by the terminating port.

(N)

(N)

(1)As of October 6, 2004, X.25 and X.75 protocols are obsolete and limited to existing installations, at existing locations, for existing customers.

(This page filed under Transmittal No. 170)

ACCESS SERVICE

6. Switched Access Service (Cont'd)6.2 Provision and Description of Switched Access Service (Cont'd)6.2.7 X.25 (Cont'd)⁽¹⁾

(C)

(C) Optional Features (Cont'd)

(6) Closed User Groups (CUG) allow a customer to establish exclusive user groups, which are private networks within the X.25 network. Each participant's call originating or call terminating capabilities can be individually defined. Each data network address may be included in up to ten separate CUGs. Sub-options include:

- a) Basic, required for each separate CUG in which DNA is a member
- b) incoming and outgoing calls limited to a customer's CUG
- c) Incoming calls allowed from the open X.25 network
- d) Outgoing calls allowed to the open X.25 network
- e) Incoming calls allowed within the CUG
- f) Outgoing calls allowed within the CUG

(7) Data Terminating Equipment (DTE) Back-up allows for the automatic rerouting of a call to an alternate, predetermined DNA. DTE are devices (such as a computer or teleprinter), generally belonging to the end user, that provide the functional and electrical interface to the communications medium.

The DTE is connected to Data Circuit Equipment (DCE), which are devices and connections placed at the interface to a network by the network provider.

(8) Additional logical channels

- (a) A maximum of 4095 logical channels may be ordered per X.75 Internetwork Interface. However, a practical limit of logical channels assigned to a single interface should be determined or a significant degradation of service may occur.

(1) As of October 6, 2004, X.25 and X.75 protocols are obsolete and limited to existing installations, at existing locations, for existing customers.

(N)
(N)

(This page filed under Transmittal No. 170)

ACCESS SERVICE

6. Switched Access Service (Cont'd)6.2 Provision and Description of Switched Access Service (Cont'd)6.2.7 X.25 (Cont'd)⁽¹⁾

(C)

(C) Optional Features (Cont'd)

- (9) A Permanent Virtual Circuit (PVC) is a feature which is established between two logical channels and remains in the data transfer phase. No set up or clearing procedures are required to send data across this circuit. Calls generated at the logical channel at one end of the Permanent Virtual Circuit can only be transported to the logical channel located at the opposite end. No calls from the Permanent Virtual Circuit can access the open X.25 network. PVCs are maintained only within the LATA.

(D) Measurement and Billing Information

- (1) Usage charges listed in 6.8.1 include both peak and non-peak period rates. Peak period rates are defined as applicable from 8:00 a.m. up to but not including 5 p.m. Monday through Friday, except Holidays as defined in Section 2.6.
- (2) Recurring and usage rate charges are billed on a monthly basis and do not include detailed billing. Usage rate charges consist of call set-up and segment rate elements. For the monthly sum of each usage rate element charge, any fraction of a cent will be rounded up to the next whole cent.
- (3) The call set-up process occurs at the beginning of each X.25 call attempt. It allows a connection between the originating and terminating interface. A usage rate charge of one set-up per call is billed to the interface which is collecting the charges.
- (4) A segment is the basic billing unit for X.25 data transport. One segment will be billed for every 128 octets, or portion thereof, of user data that is transmitted.

(1) As of October 6, 2004, X.25 and X.75 protocols are obsolete and limited to existing installations, at existing locations, for existing customers.

(N)
(N)

(This page filed under Transmittal No. 170)

ACCESS SERVICE

6. Switched Access Service (Cont'd)

6.2 Provision and Description of Switched Access Service (Cont'd)

6.2.7 X.25 (Cont'd)⁽¹⁾

(C)

(D) Measurement and Billing Information (Cont'd)

- (5) Fractions of minutes per call are rounded up to the nearest whole minute.
- (6) Charges accrued for portions of calls that span multiple billing periods will be applied in the appropriate billing period.
- (7) The time system, standard or daylight savings, legally in use in California will determine whether peak or off-peak rate treatment applies.
- (8) Rate period specific billing occurs when a call extend beyond one rate period. The appropriate rate treatment, either peak or off-peak, applies to the respective periods of the call.

(1) As of October 6, 2004, X.25 and X.75 protocols are obsolete and limited to existing installations, at existing locations, for existing customers.

(N)
(N)

(This page filed under Transmittal No. 170)

Issued: September 21, 2004

Effective: October 6, 2004

Four AT&T Plaza, Dallas, Texas 75202

ACCESS SERVICE

6. Switched Access Service (Cont'd)6.2 Provision and Description of Switched Access Service (Cont'd)6.2.8 Access Line Arrangement (ALA)(A) Description

- (1) ALA is provided in connection with the Telephone Company's end offices. At the option of the customer, ALA is provided on a single or multiple line group basis and is arranged for originating calling only, terminating calling only, or two-way calling. ALA, which is available to all customers, provides line side access to Telephone Company end office switches with an associated seven digit local telephone number for the customer's use in originating communications from and terminating communications to an Interexchange Carrier's interstate service or a customer provided interstate communications capability. The customer must specify the Interexchange Carrier to which the ALA service is connected or, in the alternative, specify the means by which the ALA access communications is transported to another state. (D)
- (2) ALA provides for a line side termination at the first point of switching, which shall be selected by the Telephone Company within the requested LATA, unless the customer requests a different location at which Telephone Company facilities and measurement capabilities are available to accommodate such a request.
- (3) The Telephone Company assigns a seven digit telephone number associated with the selected end office to provide access to ALA in the originating direction. The assigned number will be in the form NXX-XXXX. If the customer requests a specific number that is currently unassigned, the requested number will be assigned to the customer if the Telephone Company can comply with that request with reasonable effort.

(This page filed under Transmittal No. 371)

ACCESS SERVICE

6. Switched Access Service (Cont'd)6.2 Provision and Description of Switched Access Service (Cont'd)6.2.8 Access Line Arrangement (ALA) (Cont'd)(A) Description (Cont'd)

(4) At the option of the customer, ALA will be provided:

(a) with either ground start or loop start supervisory signaling and

(b) on a single or multiple line group basis.

(5) When ALA is used in the originating direction, no address signaling is provided by the Telephone Company. If such signaling is required, it must be provided by the customer's end user using inband tone signaling techniques. Inband tone address signals will not be regenerated by the Telephone Company and will be subject to the ordinary transmission capabilities of the Local Transport provided.

(6) When used in the terminating direction, ALA is arranged with dial tone start-dial signaling. At the option of the customer, terminating ALA may be arranged for dial pulse or dual tone multifrequency address signaling, subject to the availability of equipment at the first point of switching. When ALA is provided with a Hunt Group or Uniform Call Distribution arrangement, all ALA will be provisioned with the same type of address signaling.

ALA switching, when used in the terminating direction, may be used to access valid NXXs in the LATA, local operator service (0- and 0+), Directory Assistance (411 where available and 555-1212), emergency reporting service (911 where available), time or weather announcement services of the Telephone Company, community information services of an information service provider, and other customers' services (by dialing the appropriate digits). Charges for ALA terminating calls requiring operator assistance or calls to 611 or 911 will only apply where sufficient call details are available.

(This page filed under Transmittal No. 1)

ACCESS SERVICE

6. Switched Access Service (Cont'd)6.2 Provision and Description of Switched Access Service (Cont'd)6.2.8 Access Line Arrangement (ALA) (Cont'd)(A) Description (Cont'd)

(7) Additional non-access charges will also be billed on a separate account for (1) an operator surcharge, as set forth in the local exchange tariffs, for local operator assistance (0- and 0+) calls, (2) calls to certain community information services, for which rates are applicable under Telephone Company exchange service tariffs, e.g. 976 (DIAL-IT) Network Services, and (3) calls from an ALA line to another customer's service in accordance with that customer's applicable service rates when the Telephone Company performs the billing function for that customer. For ALA calls to Directory Assistance (411 and 555-1212 where available), Switched Access Service usage rates will not apply. Instead, ALA calls to this service are subject to the Directory Assistance and Directory Access Service per call rates as set forth in Section 9.7 (A) and (B).

(8) When ALA for an individual customer (a single or entire hunt group) is discontinued at an end office, an intercept announcement is provided. This arrangement provides, for a limited period of time, an announcement that the service associated with the number dialed has been discontinued.

(B) ALA Optional Features

(1) Common Switching

- (a) Hunt Group Arrangement
- (b) Uniform Call Distribution Arrangement
- (c) Nonhunting Number for use with Hunt Group Arrangement or Uniform Call Distribution Arrangement
- (d) Call Denial on Line or Hunt Group
- (e) Service Code Denial on Line or Hunt Group
- (f) Three-way Call Transfer
- (g) Hunt Group - C.O. Announcements
- (h) Hunt Group - Overflow

(This page filed under Transmittal No. 1)

ACCESS SERVICE

6. Switched Access Service (Cont'd)6.2 Provision and Description of Switched Access Service (Cont'd)6.2.8 Access Line Arrangement (ALA) (Cont'd)(B) ALA Optional Features (Cont'd)

(1) Common Switching (Cont'd)

- (I) Uniform Call Distribution with Queuing
- (j) Band Advance Arrangement for Use with WATS Access Line Service
- (k) Hunt Group Arrangement for Use with WATS Access Line Service
- (l) Uniform Call Distribution Arrangement for Use with WATS Access Line Service
- (m) Nonhunting Number for Use with Hunt Group Arrangement or Uniform Call Distribution Arrangement for Use with WATS Access Line Service
- (n) Answer Supervision - Lineside
- (o) Calling Number Delivery via ICLID

(2) Transport Termination Optional Features

- (a) Two-way operation with dial-pulse address signaling and loop-start supervisory signaling
- (b) Two-way operation with dial-pulse address signaling and ground-start supervisory signaling
- (c) Two-way operation with dual-tone multifrequency address signaling and loop-start supervisory signaling
- (d) Two-way operation with dual-tone multifrequency address signaling and ground-start supervisory signaling
- (e) Terminating operation with dial-pulse address signaling and loop-start supervisory signaling
- (f) Terminating operation with dial-pulse address signaling and ground-start supervisory signaling
- (g) Terminating operation with dual-tone multifrequency address signaling and loop-start supervisory signaling

(This page filed under Transmittal No. 1)

ACCESS SERVICE

6. Switched Access Service (Cont'd)6.2 Provision and Description of Switched Access Service (Cont'd)6.2.8 Access Line Arrangement (ALA) (Cont'd)(B) ALA Optional Features (Cont'd)(2) Transport Termination Optional Features (Cont'd)

- (h) Terminating operation with dual-tone multifrequency address signaling and ground-start supervisory signaling
- (i) Originating operation with loop-start supervisory signaling
- (j) Originating operation with ground-start supervisory signaling

(3) Switched Transport Optional Features

- (a) Supervisory Signaling (as set forth in 6.1.3(A) (5) (a) preceding)
- (b) Customer-Specified Entry Switch Receive Level
- (4) Certain other features which may be available in connection with ALA are provided under the Telephone Company's General Exchange Service Tariffs. These are:
 - (a) COMSTAR Features
 - (b) Bill Number Screening
 - (c) IntraLATA Extensions
 - (d) Remote Call Forwarding

(C) Testing Capabilities

ALA is provided, in the terminating direction where equipment is available, with seven-digit access to balance (100 type) text and milliwatt (102 type) test line. In addition to the tests described in 6.1.6 preceding which are included with the installation of service, additional Cooperative Acceptance Testing and Nonscheduled Testing are available for ALA as set forth in 13.3.5 following.

(This page filed under Transmittal No. 1)

ACCESS SERVICE

6. Switched Access Service (Cont'd)6.2 Provision and Description of Switched Access Service (Cont'd)6.2.9 Access Trunk Arrangement

The Access Trunk Arrangement is provided with two switched access options. These are differentiated by their technical characteristics, e.g., the manner in which an end user accesses them for originating calls. These options are offered as ATA-950 and ATA-101XXXX. The ATA-950 is provided as set forth in 6.2.10 following. The ATA-101XXXX is set forth in 6.2.11 following.

6.2.10 Access Trunk Arrangement-950 (ATA-950)(A) Description

ATA-950, which is available to all customers, provides trunkside access to Telephone Company end office switches with an associated uniform 950-XXXX access code for non-8yy and non-900 Access Service for the customer's use in originating communications from and terminating communications to an IXC's interstate service or a customer provided interstate communications capability. The customer must specify the IXC to which the ATA-950 is connected or, in the alternative, specify the means by which the access communication is transported to another state. (T)

- (1) ATA-950 may be directly routed only to appropriately equipped end office switches. ATA-950 may be provided via Telephone Company designated access tandem switches to other Telephone Company end office switches. (D)
(D)
(D)
- (2) ATA-950 switch trunk equipment is provided with (a) wink start start-pulsing signaling and (b) answer and disconnect supervisory signaling.

(This page filed under Transmittal No. 371)

ACCESS SERVICE

6. Switched Access Service (Cont'd)6.2 Provision and Description of Switched Access Service (Cont'd)6.2.10 Access Trunk Arrangement-950 (ATA-950) (Cont'd)(A) Description (Cont'd)

- (3) ATA-950 is provided with multifrequency address signaling. With the exception of rotary dial station signaling. Any other signaling required by the customer in the originating direction must be provided by the customer's end user using inband tone signaling techniques. Inband tone address signals will not be regenerated by the Telephone Company and will be subject to the ordinary transmission capabilities of the Switched Transport provided.
- (4) When all ATA-950 service is discontinued at an end office and/or in a LATA, an intercept announcement indicating that the service associated with the number dialed has been discontinued will be provided for a limited period.
- (5) ATA-950 switching, when used in the terminating direction, may be used to access valid NXXs in the LATA, time or weather announcement services of the Telephone Company, community information services of an information service provider, and other customer's services (by dialing the appropriate digits). When directly routed to an end office, only those valid NXX codes served by that end office may be accessed. When routed through an access tandem, only those valid NXX codes served by end offices subtending the access tandem may be accessed. The customer will also be billed additional non-access charges for calls to certain community information services for which rates are applicable under the Telephone Company Exchange Service Tariff, e.g, 976 Network Service.

(This page filed under Transmittal No. 1)

ACCESS SERVICE

6. Switched Access Service (Cont'd)6.2 Provision and Description of Switched Access Service (Cont'd)6.2.10 Access Trunk Arrangement-950 (ATA-950) (Cont'd)(A) Description (Cont'd)

Additionally, non-access charges will also be billed for calls from an ATA-950 trunk to another customer's service in accordance with that customer's applicable service rates when the Telephone Company performs the billing function for that customer. Calls in the terminating direction will not be completed to 950-XXXX access codes, local operator assistance (0- and 0+), Directory Assistance (411 and 555-1212), service codes 611 and 911 and 101XXXX access codes. Calls will be completed to Directory Assistance (NPA-555-1212 or 555-1212) when ATA-950 switching is combined with Directory Assistance switching. The combination of ATA-950 Switched Access Service with DA service is provided as set forth in 9. following.

ATA-950 may not be switched, in the terminating direction to ATA-950, ATA-101XXXX or Feature Groups B or D. (T)

- (6) The access code for ATA-950 switching is a uniform access code. The form of the uniform access code is 950-XXXX for carriers. These uniform access codes will be the assigned access numbers of all ATA-950 Switched Access Service provided to the customer by the Telephone Company.
- (7) ATA-950 provides trunkside access to Telephone Company end office switches, either directly or through a Telephone Company designated Switched Access Service tandem switch. The Telephone Company will establish a trunk group (or groups) between the customer premises and end office or access tandem switches, based on the technical limitations imposed by the type, directionality and quantity of traffic specified by the customer. Different Switched Access Service arrangements may be combined in a single trunk group at the option of the Telephone Company.
- (8) Bill Number Screening is provided under the Telephone Company's local and/or general exchange service tariffs.

(This page filed under Transmittal No. 371)

ACCESS SERVICE

6. Switched Access Service (Cont'd)6.2 Provision and Description of Switched Access Service (Cont'd)6.2.10 Access Trunk Arrangement-950 (ATA-950) (Cont'd)(B) ATA-950 Package Optional Features(1) Common Switching Optional Features

- (a) Up to 10 Digit Outpulsing of access digits to customer
- (b) Alternate Traffic Routing
- (c) Band Advanced Arrangement for use with WATS access
- (d) Hunt Group Arrangement for use with WATS Access Line Service
- (e) Uniform Call Distribution Arrangement for use with WATS Access Line Service
- (f) Nonhunting Number for Use with Hunt Group Arrangement or Uniform Call Distribution Arrangement for use with WATS Access Line
- (g) LATA-wide Terminating Access
- (h) Automatic Number Identification

(C)

(2) WATS Access Line Termination Optional Feature

- (a) E & M Supervisory Signaling

(3) Transport Termination Optional Features

- (a) Rotary Dial Station Signaling

(4) Switched Transport Optional Features

- (a) Customer Specification of Switched Transport Termination
- (b) Supervisory Signaling (as set forth in 6.1.3(A) (5) (a) preceding)
- (c) Customer Specified Entry Switch Receive Level

(This page filed under Transmittal No. 371)

ACCESS SERVICE

6. Switched Access Service (Cont'd)6.2 Provision and Description of Switched Access Service (Cont'd)6.2.10 Access Trunk Arrangement-950 (ATA-950) (Cont'd)(C) Testing Capabilities

ATA-950 is provided, in the terminating direction where equipment is available, with seven-digit access (or ten-digit access if required with LATA-wide terminating access) to balance (100 type) test line, milliwatt (102 type) test line, nonsynchronous or synchronous test line, automatic transmission measuring (105 type) test line, digital circuit loopback (108 type) test line, loop-around test line, short-circuit test line and open-circuit test line. In addition to the tests described in 6.1.6 preceding which are included with the installation of service, additional Cooperative Acceptance Testing, Automatic Scheduled Testing, Cooperative Scheduled Testing, Manual Scheduled Testing, and Non-Scheduled Testing, are available in 13.3.5 (Testing Services) following.

(C)
(C)

(This page filed under Transmittal No. 371)

ACCESS SERVICE

6. Switched Access Service (Cont'd)6.2 Provision and Description of Switched Access Service (Cont'd)6.2.11 Access Trunk Arrangement-101XXXX (ATA-101XXXX)(A) Description

The ATA-101XXXX is available to all customers at Telephone Company designated electronic end office switches, whether routed directly or via Telephone Company designated electronic access tandem switches. ATA-101XXXX provides trunkside access to end office switches with an associated uniform 101XXXX access code for use in originating and terminating communications.

- (1) The access code for ATA-101XXXX switching is a uniform access code of the form 101XXXX. These uniform access codes will be the assigned access numbers of all ATA-101XXXX access provided to the customer by the Telephone Company. No access code is required for calls to a customer over ATA-101XXXX Switched Access Service if the end user's telephone exchange service is arranged for presubscription to that customer, as set forth in 13.3.3 (Presubscription and Preselection) following.

When the 101XXXX access code is used, ATA-101XXXX switching also provides for dialing the digit 0 for access to the customer's operator, 911 for access to the Telephone Company's emergency reporting service, or the end-of-dialing digit (#) for cut-through access to the customer's premises.

- (2) When the ATA-101XXXX is provided with PSDS Switching Capability, the dialing pattern will be modified as set forth in 6.2.4.(A)(10) preceding.
- (3) ATA-101XXXX switch trunk equipment is provided with:
 - (a) wink start start-pulsing signaling and
 - (b) answer and disconnect supervisory signaling, or out of band signaling when the CCSAC optional feature is specified.

(This page filed under Transmittal No. 1)

ACCESS SERVICE

6. Switched Access Service (Cont'd)6.2 Provision and Description of Switched Access Service (Cont'd)6.2.11 Access Trunk Arrangement-101XXXX (ATA-101XXXX) (Cont'd)(A) Description (Cont'd)

- (4) ATA-101XXXX is provided with multifrequency address or SS7 signaling. Up to 15 digits of the called party number dialed by the customer's end user using dual tone multifrequency or dial pulse address signaling will be provided by the Telephone Company equipment to the customer premises where the Switched Access Service terminates. Called party number signals will be subject to the ordinary transmission capabilities of the Switched Transport provided. (T)
(C)
- (5) ATA-101XXXX switching, when used in the terminating direction, may be used to access valid NXXs in the LATA, time or weather announcement services of the Telephone Company, community information services of an information service provider, and other customer ATA-101XXXX services (by dialing the appropriate codes) when such services can be reached using valid NXX codes. When directly routed to an end office, only those valid NXX codes service by that office may be accessed. When routed through an access tandem, only those valid NXX codes served by end offices subtending the access tandem may be accessed. The customer will also be billed additional non-access charges for calls to certain community information services, for which rates are applicable under Telephone Company exchange service tariffs, e.g, 976 Network Service. Additionally, non-access charges will also be billed for calls from an ATA-101XXXX trunk to another customer's service in accordance with that customer's applicable service rates when the Telephone Company performs the billing function for that customer. Calls in the terminating direction will not be completed to 950-XXXX access codes, local operator assistance (0- and 0+), Directory Assistance (411 and 555-1212), services codes 611 and 911 and 101XXXX access codes. Calls will be completed to (T)
(T)

(This page filed under Transmittal No. 371)

ACCESS SERVICE

6. Switched Access Service (Cont'd)6.2 Provision and Description of Switched Access Service (Cont'd)6.2.11 Access Trunk Arrangement-101XXXX (ATA-101XXXX) (Cont'd)(A) Description (Cont'd)

(5) (Cont'd)

Directory Assistance (NPA-555-1212 and 555-1212) when ATA-101XXXX switching is combined with Directory Assistance switching. The combination of ATA-101XXXX Switched Access Service with DA service is provided as set forth in 9, following. ATA-101XXXX may not be switched in the terminating direction to other Switched Access Services.

(T)

(Z)

(6) The Telephone Company will establish a trunk group or groups for the customer at end office switches or access tandem switches where ATA-101XXXX switching is provided. When required by technical limitations, a separate trunk group will be established for each type of ATA-101XXXX switching arrangement provided. ATA-101XXXX or other switching arrangements may be combined in a single trunk group at the option of the Telephone Company.

(7) Where no access code is required, or available, the number dialed by the end user shall be a seven to eleven-digit number for calls in the NANP. For IDDD is available for calls outside the NANP, a seven to fifteen-digit number may be dialed. The form of the numbers dialed by the end user is NXX-XXXX, 0 or 1+ NXX-XXXX, NPA + NXX-XXXX, 0 or 1+ NPA + NXX-XXXX, and, when the end office is equipped for IDDD, 01+ CC + NN or 011+ CC + NN.

(C)

(This page filed under Transmittal No. 371)

ACCESS SERVICE

6. Switched Access Service (Cont'd)

6.2 Provision and Description of Switched Access Service (Cont'd)

6.2.11 Access Trunk Arrangement-101XXXX (ATA-101XXXX) (Cont'd)

(A) Description (Cont'd)

(8) ATA-101XXXX switching will be arranged to accept calls from telephone exchange service locations without the need for dialing 101XXXX uniform access code. Each telephone exchange service line may be marked with a presubscription code to identify which 101XXXX code its calls will be directed to for interLATA service. Presubscription codes are applied as set forth in 13.3.3 following. (T)

(9) When the 101XXXX 1+ or 011+ sent-paid access code is dialed from a Telephone Company pay telephone to a customer that has not ordered per 6.3.2(B) or (C) following, the calls will be routed to a Telephone Company recording. (T)

When a customer has had ATA-950 or FGB access in an end office and subsequently replaces the access with ATA-101XXXX access, at the customer's request and where facilities permit, the Telephone Company, will, for a period of 90 days, direct calls dialed by the customer's end users using the customer's previous ATA-950 or Feature Group B access service. The customer must be prepared to handle normally dialed ATA-101XXXX calls, as well as calls dialed with the ATA-950 access code which require the customer to receive additional address signaling from the end user. Such calls will be rated as ATA-101XXXX. (T)

(10) When a customer has had ATA-950 access in an end office and subsequently replaces the ATA-950 access with ATA-101XXXX access, at the mutual agreement of the customer and the Telephone Company, the Telephone Company will direct calls dialed by the customer's end users using the customer's previous ATA-950 access code to the customer's ATA-101XXXX access service. (T)

(T)

(This page filed under Transmittal No. 371)

ACCESS SERVICE

6. Switched Access Service (Cont'd)6.2 Provision and Description of Switched Access Service (Cont'd)6.2.11 Access Trunk Arrangement-101XXXX (ATA-101XXXX) (Cont'd)(A) Description (Cont'd)

(10) (Cont'd)

When a customer has both ATA-950 and ATA-101XXXX access in the same end office or separate end offices which subtend the same access tandem and chooses to route his originating ATA-950 calls over ATA-101XXXX access, the Telephone Company will direct calls dialed by the customer's end users using the customer's ATA-950 access code to the customer's ATA-101XXXX access service. Such calls will be rated as ATA-101XXXX. (D)

The customer must be prepared to handle normally dialed ATA-101XXXX calls, as well as, calls dialed with the ATA-950 access code which requires the customer to receive additional address signaling from the end user. Such calls will be rated as ATA-101XXXX.

- (11) ATA-101XXXX is available to accept calls with multifrequency or CCSAC signaling. With CCSAC signaling, the customer may also order Charged Number (CN) as an additional feature.

(B) ATA-101XXXX Optional Features(1) Common Switching Optional Features

- (a) Automatic Number Identification (ANI)
- (b) Service Class Routing
- (c) Alternate Traffic Routing
- (d) Call Gapping Arrangement
- (e) Trunk Access Limitation
- (f) International Carrier Option
- (g) End Office End User Line Service Screening for Use with WATS Access Line Service
- (h) Hunt Group Arrangement for Use with WATS Access Line Service
- (I) Hunt Group Arrangement for Use with PVN Access Line Service

(This page filed under Transmittal No. 517)

ACCESS SERVICE

6. Switched Access Service (Cont'd)6.2 Provision and Description of Switched Access Service (Cont'd)6.2.11 Access Trunk Arrangement-101XXXX (ATA-101XXXX) (Cont'd)(B) ATA-101XXXX Optional Features (Cont'd)(1) Common Switching Optional Features (Cont'd)

(j) Uniform Call Distribution Arrangement for Use with WATS Access Line Service (T)

(k) Nonhunting Number for Use with Hunt Group Arrangement or Uniform Call Distribution Arrangement for WATS Access Line Service

(l) Band Advance Arrangement for Use with WATS Access Line Service

(m) Cut-through

(n) Public Switched Digital Service (PSDS) Access

(o) Calling Party Number (CPN)*

(p) Charge Number (CN)

(q) Carrier Selection Parameter (CSP)

(r) Access Transport Parameter (ATP)

(2) Transport Termination Optional Features

(a) Operator Trunks - Modified Operator Services (MOS) Direct - i.e., Coin and Combined Coin and Non-Coin.

(b) Operator Trunks - Exchange Access Operator Services Systems (EAOSS) - i.e., Coin 1+ and 011+ sent-paid as well as 0+, 00- and 01+ where technically feasible.

(This page filed under Transmittal No. 371)

ACCESS SERVICE

6. Switched Access Service (Cont'd)6.2 Provision and Description of Switched Access Service (Cont'd)6.2.11 Access Trunk Arrangement-101XXXX (ATA-101XXXX) (Cont'd)(B) ATA-101XXXX Optional Features (Cont'd)(3) Switched Transport Optional Features

- (a) Supervisory Signaling (as set forth in Section 6.1.3(A) (5) (a)). (T)
(T)
- (b) Common Channel Signaling Access Capability (CCSAC) (as set forth in Section 6.1.3(A) (5) (d)). (T)
(D)
(D)
- (c) 64 Clear Channel Capability (CCC) (as set forth in Section 6.1.3(A) (5) (e)). (T)
(T)

(4) WATS Access Line Terminating Optional Features

- (a) E & M Supervisory Signaling
- (b) Dialed Number Identification Service

(5) Tandem Signaling Optional Feature

- (a) CIC and OZZ (as set forth in Section 6.1.3(A) (5) (f)). (T)
(T)
- (b) TNS (as set forth in Section 6.1.3(A) (5) (f)). (T)

(This page filed under Transmittal No. 550)

ACCESS SERVICE

6. Switched Access Service (Cont'd)

6.2 Provision and Description of Switched Access Service (Cont'd)

6.2.11 Access Trunk Arrangement-101XXXX (ATA-101XXXX) (Cont'd)

(C) Testing Capabilities

ATA-101XXXX is provided, in the terminating direction where equipment is available, with seven-digit access to balance (100 type) test line, milliwatt (102 type) test line, nonsynchronous or synchronous test line, automatic transmission measuring (105 type) test line, digital circuit loopback (108 type) test line, loop-around test line, short-circuit test line and open-circuit test line. In addition to the tests described in 6.1.6 preceding which are included with the installation of service, additional Cooperative Acceptance Testing, Automatic Scheduled Testing, Cooperative Scheduled Testing, Manual Scheduled Testing, and Non-Scheduled Testing, are available for ATA-101XXXX as set forth in 13.3.5 (Testing Services) following.

(C)
(C)

(This page filed under Transmittal No. 371)

ACCESS SERVICE

6. Switched Access Service (Cont'd)6.2 Provision and Description of Switched Access Service (Cont'd)6.2.12 Direct Inward Dial (DID) Switched Access Service(A) Description

- (1) The DID Switched Access Service is a Private Branch Exchange (PBX) Trunk that uses Central Office trunks in connection with providing direct inward dialing service from the telecommunications network to the customer's premises for use in connection with dial switching or number identifying equipment. DID Switched Access Service is available only in the terminating direction to the PBX.
- (2) DID Switched Access Service is provided as a trunkside switching service. The switch trunk equipment is provided with wink start-pulsing signals and answer and disconnect supervisory signaling. Three or four digit outpulsing of called party telephone numbers to the customer can be provided.
- (3) DID Switched Access Service must be ordered with blocks of telephone numbers. DID station number assignments are provisioned in blocks of 100. Vacant DID stations or stations not in use must be intercepted by the customer. A DID station number cannot be removed from a group to provide non-DID service.
- (4) DID Switched Access Service is provided with Dual Tone Multifrequency (DTMF) or Dial Pulse (DP) address signaling when provided at suitably equipped electronic end offices. No other address signaling is provided by the Telephone Company. Additional address signaling, if required by the customer, must be provided by the customer's end user using inband tone signaling techniques. Such inband tone address signals will not be regenerated by the Telephone Company and will be subject to the ordinary transmission capabilities of the Switched Transport.

(This page filed under Transmittal No. 1)

ACCESS SERVICE

6. Switched Access Service (Cont'd)6.2 Provision and Description of Switched Access Service (Cont'd)6.2.12 Direct Inward Dial (DID) Switched Access Service (Cont'd)(A) Description (Cont'd)

- (5) The Telephone Company will establish a trunk group or groups for the customer at end office switches where DID Switched Access Service is provided. DID Switched Access Service requires a minimum of one circuit termination per trunk group requested. A separate identity is required for each separate trunk group.
- (6) DID Switched Access Service requires a minimum of two DID PBX trunks per block of 100 telephone numbers requested.

(B) Transmission Specifications

DID Switched Access Service is provided a transmission quality parameter of no more than 5.5 db loss from the customers serving wire center to the PBX. DID Switched Access Service is provided only as a two-wire analog service.

(C) Testing Capabilities

In addition to the installation and acceptance test normally provided with the service, additional Cooperative Acceptance Testing, Cooperative Scheduled Testing, Manual Scheduled Testing and Non-Scheduled Testing are available as set forth in 13.3.5 (Testing Services) following.

(D) Limitations

DID Switched Access Service central office trunk lines cannot be:

- (1) extended to an off-premise location;
- (2) coterminated with residence service.

(This page filed under Transmittal No. 1)

ACCESS SERVICE

6. Switched Access Service (Cont'd)6.2 Provision and Description of Switched Access Service (Cont'd)6.2.12 Direct Inward Dial (DID) Switched Access Service (Cont'd)(E) Interoffice Mileage

Interoffice mileage is applicable when the customer orders the DID Switched Access Service from a Telephone Company end office other than the customer's serving wire center. The interoffice mileage rate element will apply to the airline transport miles between the customer's serving wire center and the end office where the DID Switched Access Service connection resides. Airline mileage is measured using the V&H Coordinates Method as set forth in the NECA Tariff F.C.C. No. 4.

(F) DID Trunk Queuing

The DID Trunk Queuing option permits customers of DID Switched Access Service to hold a specified number of calls in queue for delayed delivery when all circuits in a DID trunk group are busy. This option allows calls, which otherwise would have received a busy signal, to be held and rerouted to the customer's DID trunk group when a circuit becomes available.

Calls held in queue will receive a recorded delay call announcement and are delivered on a "first in first out" basis. The customer may order and record up to a maximum of four delay announcements. Each delay announcement may vary in length from three to twenty four seconds.

DID Number Conditioning is required feature on all DID numbers assigned to a trunk group equipped with DID Trunk Queuing. DID Number Conditioning for use with DID Trunk Queuing must be assigned in sequential order. The customer determines the number of queue slots they require, however, the number of slots cannot exceed the number of DID trunks provisioned in a DID trunk group.

DID Trunk Queuing is available only from the Telephone Company's LAESS electronic end offices where facilities and operating conditions permit.

(This page filed under Transmittal No. 1)

ACCESS SERVICE

6. Switched Access Service (Cont'd)6.2 Provision and Description of Switched Access Service (Cont'd)6.2.12 Direct Inward Dial (DID) Switched Access Service (Cont'd)(G) Description and Application of Rates and Charges

Monthly recurring rates and nonrecurring charges for DID Switched Access Service can be found in 6.8.11 following.

The access rate components of Local Switching and Switched Transport are recovered through flat rated, non-usage sensitive rate elements of the DID PBX Trunk and the DID Circuit Termination. An interstate Carrier Common Line (CCL) charge is not applicable to DID Switched Access Service because this service is a terminating only service and terminating CCL usage is presently charged to all interstate Feature Groups, ALA and ATA services required to complete IXC traffic to a DID PBX Trunk.

(This page filed under Transmittal No. 1)

Issued: April 27, 2000

Effective: May 12, 2000

Four AT&T Plaza, Dallas, Texas 75202

ACCESS SERVICE

6. Switched Access Service (Cont'd)6.2 Provision and Description of Switched Access Service (Cont'd)6.2.13 Toll Free Access Service

Toll Free Access Service (8yy) is an originating offering utilizing FGD Switched Access Service and/or the SS7 Signaling Network. The basic service provides a customer identification function with Area of Service (AOS) routing, based on the dialed toll free number, at Telephone Company Toll Free Access Service Switching Points (SSPs) and the Toll Free Access Service Control Point (SCP). AOS routing is based on originating LATA, NPA, or NPA-NXX. (T)

When a toll free call is originated by an end user, the toll free call is held at the SSP while a query is launched to the SCP. The customer identification with AOS, in the form of SS7 signaling information, is passed back from the SCP to the SSP from which the query originated and the call can then be routed to the correct customer location.

The IXC will be assessed a charge only for a completed data base query. A data base query consists of a signaling query and answer. The call is held at the SSP while the data base query is performed. When the database returns the signaling information to the SSP, enabling the call to be directed to the appropriate carrier, the 8yy data base query is deemed completed. Billing for the signaling will commence at the time the data base query is completed. The IXC will be assessed a charge for a completed data base query even if the underlying call is not completed (e.g., the call for which the data base query was made). (T)

Calls originating from a service area in which the customer has not ordered Toll Free Access Service will be routed to intercept.

Customer identification for Canadian and Caribbean toll free numbers will be performed by Six Digit Master Number List Turnaround.

(This page filed under Transmittal No. 371)

ACCESS SERVICE

6. Switched Access Service (Cont'd)

6.2 Provision and Description of Switched Access Service (Cont'd)

6.2.13 Toll Free Access Service

In addition to the basic customer identification function with AOS, Toll Free Access Service offers the following optional features:

(A) POTS Translation

The customer may choose to have the dialed toll free number translated to the terminating POTS number and delivered to the customers location in that form.

(This page filed under Transmittal No. 1)

Issued: April 27, 2000

Effective: May 12, 2000

Four AT&T Plaza, Dallas, Texas 75202

ACCESS SERVICE

6. Switched Access Service (Cont'd)

6.2 Provision and Description of Switched Access Service (Cont'd)

6.2.13 Toll Free Access Service (Cont'd)

(B) Multiple Destination and Routing

The customer may create routing schemes utilizing:

- (1) Time of Day
- (2) Day of Week
- (3) Day of Year
- (4) Allocation of Traffic by Percentage
- (5) NPA-NXX-XXXX

Toll Free Access Service will be provisioned in accordance with the technical characteristics available with FGD and ATA-10XXXX and with SS7 network protocol as described in Pacific Bell Network Interface Document PUB-L-780023-PB/NB and Bellcore Common Channel Signaling Network Specification Technical Reference TR-TSV-000905.

(T)

Rates and charges associated with Toll Free Access Service are as described in 6.8.12 following.

(This page filed under Transmittal No. 371)

ACCESS SERVICE

6. Switched Access Service (Cont'd)6.2 Provision and Description of Switched Access Service (Cont'd)6.2.14 500 Access Service

500 Access Service is an originating service utilizing trunk side Switched Access Service and is available at appropriately equipped Telephone Company end offices or tandem switches. The service provides a 500 Access Service customer identification function based on the dialed 500 number.

When a 0+500+NXX-XXXX or 1+500+NXX-XXXX call is originated by an end user, the Telephone Company will perform the 500 Access Service customer identification function based on the dialed digits to determine the customer location to which the call is to be routed. If the call originates from an end office switch not equipped to provide the 500 Access Service customer identification function, the call will be routed to an office at which the function is available. Once 500 Access Service customer identification has been established, the call will be routed to the customer. Calls originating in an end office switch in which the customer has not ordered 500 Access Service will be routed to intercept. The 500 Access Service customer has the option to order 0+ 500, 1+ 500 or both. 0+ 500 and 1+ 500 originating calls from 101XXXX, inmate service, toll restricted lines, WATS, FGA and ALA with Call Access Denial will be blocked. 1+ 500 originating calls from Coin Hard Screen, Prepay, Hotel/Motel ANI 7, Hospital, PACBELL Charge-A-Call and AT&T Public Access Line will be blocked. If the 500 Access Service customer chooses not to accept a call that the Telephone Company routes, then the 500 Access Service customer is responsible for providing its own blocking and announcement explaining the reason the call cannot be completed. If the 500 Access Service customer accepts 500 calls and subsequently cannot collect from the calling or called party, the Telephone Company is not responsible for the uncollected charges. International dialing (e.g., 01 and 011+500+NXX-XXX) will not be accepted for reaching a 500 access service customer.

(D)

(This page filed under Transmittal No. 573)

ACCESS SERVICE

6. Switched Access Service (Cont'd)6.2 Provision and Description of Switched Access Service (Cont'd)6.2.14 500 Access Service (Cont'd)

When 500 Access Service is provided from an end office, all such service will be provisioned in accordance with the technical characteristics available with FGD and ATA-101XXXX. (C)

500 Access Service originating from end offices with the calling party's identification will be provided using access signaling with overlap outpulsing and ten-digit ANI, or with SS7 out of band signaling when the customer has ordered the CCSAC optional feature with FGD or ATA-101XXXX. (C)

500 Access Service originating from an independent local exchange company non-equal access end office or handicapped sources routed via operator switches without complete end user identification will be provided using traditional signaling. 500 Access Service traffic will be combined in the same trunk group arrangement with other 500 and non-500 Access Service traffic unless the customer orders a separate trunk group only for its 500 Access Service traffic. The customer can obtain a separate trunk group using traditional signaling at the access tandem.

500 Access Service usage measurement shall be in accordance with the regulations set forth in Section 6.7.8 for FGD and ATA-101XXXX. (T)

The rates and charges for 500 Access Service are described in Section 6.8.14. (T)

(This page filed under Transmittal No. 517)

ACCESS SERVICE

6. Switched Access Service (Cont'd)6.3 Local Switching Optional Features and BSEs

Following are descriptions of the various optional features that are available in lieu of, or in addition to, the standard features provided with the Feature Groups, as outlined below.

6.3.1 Common Switching

(T)

(A) Call Denial on Line or Hunt Group

This screening option limits terminating ALA and FGA calls to completion within the LATA where the ALA and FGA line resides. InterLATA and international calls are blocked as well as calls which may potentially terminate outside the LATA. Blocked calls are:

- Operator-handled calls (0-, 00-, 0+, 011+, 01+)
- Calls to 950 NXX codes
- Calls to the 900 NPA
- Calls to 976 NXX code
- Calls to 101XXXX interLATA
- Calls to 959 NXX code

The call denial option allows calls to terminate to any NXX within the LATA served by the ALA and FGA line that doesn't have a special charge associated with it. Calls are permitted to 611, 911, 7DZUM, 8yy and 7D/10D intraLATA toll.

Blocked calls are routed to a reorder tone or recorded announcement. This feature is provided in all Telephone Company end offices. This option is available with ALA and FGA.

(T)

(D)

(This page filed under Transmittal No. 371)

ACCESS SERVICE

6. Switched Access Service (Cont'd)6.3 Local Switching Optional Features and BSEs (Cont'd)6.3.1 Common Switching (Cont'd)(B) Service Code Denial on Line or Hunt Group

This screening option disallows completion of terminating ALA and FGA calls to local directory assistance (411 and 555-1212), to service codes 611 and 911, and to local operator assistance (0- and 00-). Blocked calls are routed to a reorder tone or recorded announcement. This feature is provided in all Telephone Company end offices. This option is available with ALA and FGA.

(D)

(C) Hunt Group Arrangement

This option provides the ability to sequentially access one of two or more line side connections in the originating direction, when the access code of the line group is dialed. This feature is provided in all Telephone Company end offices. It is available with ALA and FGA. ALA and FGA services with different methods of providing off-hook supervisory signaling cannot be mixed in the same hunt group arrangement.

(This page filed under Transmittal No. 371)

ACCESS SERVICE

6. Switched Access Service (Cont'd)6.3 Local Switching Optional Features and BSEs (Cont'd)6.3.1 Common Switching (Cont'd)(D) Uniform Call Distribution Arrangement

This option provides a type of multiline hunting arrangement which provides for an even distribution of calls among the available lines in a hunt group. Where available, this feature is provided in Telephone Company end offices. It is available with ALA and FGA.

(D)

(E) Nonhunting Number for Use with Hunt Group or Uniform Call Distribution Arrangement (NHN)

This option provides an arrangement for an individual line within a multiline hunt or uniform call distribution group that provides access to that line within the hunt or uniform call distribution group when it is idle or provides busy tone when it is busy, when the nonhunting number is dialed. Where available, this feature is provided in Telephone Company end offices. It is available with ALA and FGA.

(D)

(D)

(F) Automatic Number Identification (ANI)

This option provides the automatic transmission of a seven or ten digit number and information digits to the customer's premises for calls originating in the LATA, to identify the calling station. The ANI feature is an end office software function which is associated on a call-by-call basis with (1) all individual trunks in a trunk group routed directly between an end office and a customer's premises or, where technically feasible, with (2) all individual trunks in a trunk group between an end office and an access tandem, and a trunk group between an access tandem and a customer's premises.

(C)

(C)

(This page filed under Transmittal No. 361)

ACCESS SERVICE

6. Switched Access Service (Cont'd)6.3 Local Switching Optional Features and BSEs (Cont'd)6.3.1 Common Switching (Cont'd)(F) Automatic Number Identification (ANI) (Cont'd)

The seven-digit ANI telephone number is available with FGB. Technical limitations may exist in Telephone Company switching facilities which require ANI to be provided only on a directly trunked basis for the end office to the customer's premises. ANI will be transmitted on all calls except those originating from multiparty lines or when an ANI failure has occurred. ANI is provided from end offices at which Telephone Company recording for End User billing is not provided, or where it is not required, as with 8yy service. It is not provided from end offices for which the Telephone Company needs to forward ANI to its recording equipment.

(D)

(C)

(T)

The ten-digit ANI telephone number is available with FGD, ATA-950-XXXX, and ATA-101XXXX with multifrequency address signaling. When the CCSAC optional feature is specified, the customer may obtain an ANI equivalent by ordering the Charge Number optional feature, as described in 6.3.1(AA), following. The ten-digit ANI telephone number consists of the Numbering Plan Area (NPA) plus the seven-digit ANI telephone number. The ten-digit ANI telephone number will be transmitted on all calls except those identified as multiparty lines, coin stations and coinless pay telephones using FGB, ATA-950 or ANI failure, in which case only the NPA will be transmitted (in addition to the information digits described below).

With FGB and ATA-950, technical limitations exist in the Telephone Company's switching facilities which require ordering this optional feature on trunks separate from existing FGB and ATA-950 arrangements. ANI is only available in suitably equipped end offices or access tandem switches.

Where ANI cannot be provided, e.g., on calls from 4- and 8-party services, information digits will be provided to the customer.

(This page filed under Transmittal No. 371)

ACCESS SERVICE

6. Switched Access Service (Cont'd)6.3 Local Switching Optional Features and BSEs (Cont'd)6.3.1 Common Switching (Cont'd)(F) Automatic Number Identification (ANI) (Cont'd)

The information digits supply information such as: (1) telephone number is the station billing number - no special treatment required, (2) multiparty line - telephone number is a 4- or 8-party line and cannot be identified - number must be obtained via an operator or in some other manner, (3) ANI failure has occurred in the end office switch which prevents identification of calling telephone number - must be obtained by operator or in some other manner, (4) hotel/motel originated call which requires room number identification, (5) public/semi-public screened services, hospital, etc. call which requires special screening or handling by the customer, and (6) call is an Automatic Identified Outward Dialed (AIOD) call from customer premises equipment. The ANI telephone number is the listed telephone number of the customer and is not the telephone number of the calling party.

Flexible ANI is an enhancement to ANI and facilitates information digits. The Flexible ANI feature allows the Telephone Company to associate new ANI information digit assignments with originating routing and screening translations as they are assigned by the North American Numbering Plan (NANP). Flexible ANI information digits are available from technically equipped end offices.

(C)

These ANI information digits are available with ATA-950, ATA-101XXXX, FGB and FGD only.

(D)

(This page filed under Transmittal No. 371)

ACCESS SERVICE

6. Switched Access Service (Cont'd)6.3 Local Switching Optional Features and BSEs (Cont'd)6.3.1 Common Switching (Cont'd)(G) Up-to-10-Digit Outpulsing of Access Digits to Customer

This option provides for the end office capability of providing up to 10-digits of the uniform access code (950-XXXX) to the customer's premises. The customer can request that only some of the digits in the access code be forwarded. The access code digits would be provided to the customer's premises using multi-frequency signaling, and transmission of the digits would precede the forwarding of ANI if the feature were provided. It is available with ATA-950 and FGB.

(C)

(C)

(H) Cut-Through

This option allows end users of the customer to reach the customer's premises by dialing 101XXXX + #. This option provides for connection of the call to the premises of the customer indicated by the 101XXXX code upon receipt of the # digit which indicates end of dialing. The Telephone Company will not record any other dialed digits for these calls. This option is available with ATA-101XXXX and FGD.

(This page filed under Transmittal No. 371)

ACCESS SERVICE

6. Switched Access Service (Cont'd)

6.3 Local Switching Optional Features and BSEs (Cont'd)

6.3.1 Common Switching (Cont'd)

(D)

(D)

(This page filed under Transmittal No. 371)

Issued: September 6, 2007

Effective: September 22, 2007

Four AT&T Plaza, Dallas, Texas 75202

ACCESS SERVICE

6. Switched Access Service (Cont'd)

6.3 Local Switching Optional Features and BSEs (Cont'd)

6.3.1 Common Switching (Cont'd)

(D)

(N) Service Class Routing

(D)

This option provides the capability of directing originating traffic from an end office to a trunk group to a customer designated premises, based on the line class of service (e.g., coin, multiparty or hotel motel), service prefix indicator (e.g., 0-, 0+, 01+ or 011+) or service access code (e.g., 500, 8yy or 900). It is provided in suitably equipped end office or access tandem switches and is available with FGD and ATA-101XXXX.

(T)
(D)

(This page filed under Transmittal No. 371)

ACCESS SERVICE

6. Switched Access Service (Cont'd)

6.3 Local Switching Optional Features and BSEs (Cont'd)

6.3.1 Common Switching (Cont'd)

(O) Alternate Traffic Routing

(1) Multiple Customer Premises Alternate Routing

This option provides the capability of directing originating traffic from an end office (or appropriately equipped access tandem) to a trunk group (the "high usage" group) to a customer-designated premises until that group is fully loaded, and then delivering additional originating traffic (the "overflowing" traffic) from the same end office or access tandem to a different trunk group (the "final" group) to a second customer designated premises. The customer shall specify the last trunk CCS desired for the high usage group. It is provided in suitably equipped end office or access tandem switches and is available with ATA-950, ATA-101XXXX, FGB and FGD.

(2) End Office Alternate Routing When Ordered in Trunks

This option provides an alternate routing arrangement for customers who order originating traffic in trunks and these trunks serve an end office via two routes: one route via an access tandem and one direct route. The feature allows the customer originating traffic from the end office to be offered first to the direct trunk group and then overflow to the access tandem group. It is provided in suitably equipped end offices and is available with ATA-950, ATA-101XXXX, FGB and FGD. When ordered with FGB or ATA-950, only DTT rates will apply.

Alternate routing is not available with the Tandem Signaling optional feature described in Section 6.1.3(A) (5) (f), preceding.

(D)

(D)

(D)

(D)

(This page filed under Transmittal No. 371)

ACCESS SERVICE

6. Switched Access Service (Cont'd)6.3 Local Switching Optional Features and BSEs (Cont'd)6.3.1 Common Switching (Cont'd)(P) Trunk Access Limitation

This option provides for the routing of originating 900 service calls to a specified number of trunks in a trunk group, in order to limit (choke) the completion of such traffic to the customer. Calls to the designated service which could not be completed over the subset of trunks in the trunk group, i.e., the choked calls, would be routed to reorder tone. It is provided in all Telephone Company end offices. It is available with ATA-101XXXX and Feature Group D. Either Trunk Access Limitation, or Call Gapping Arrangement, 6.3.1(Q), following, should be used with originating 900 Service where a concentrated high volume of 900 calling is expected. The Telephone Company will work cooperatively with the customer to determine when such options may be necessary.

(C)

(C)

(D)

(D)

(Q) Call Gapping Arrangement

This option, provided in suitably equipped end office switches, provides for the routing of originating calls to 900 service to be switched in the end office to all transmission paths in a trunk group at a prescribed rate of flow, e.g., one call every five seconds, in order to limit (choke) the completion of such traffic to the customer. This option is activated at the request of the customer during normal business hours i.e., 8:00 a.m. to 5:00 p.m. In addition, this option may be activated for no longer than a 24 hour period. Calls to the designated service which are denied access by this feature, i.e., the choked calls, would be routed to a no-circuit announcement. It is provided in selected ATA-101XXXX and FGD equipped end offices and is available only with ATA-101XXXX and FGD. Either Trunk Access Limitation, 6.3.1(P) preceding, or Call Gapping Arrangement, following, should be used with originating 900 Service where a concentrated high volume of 900 calling is expected. The Telephone Company will work cooperatively with the customer to determine when such options may be necessary.

(This page filed under Transmittal No. 361)

ACCESS SERVICE

6. Switched Access Service (Cont'd)6.3 Local Switching Optional Features and BSEs (Cont'd)6.3.1 Common Switching (Cont'd)(R) International Carrier Option

This option allows for ATA-101XXXX and FGD end offices or access tandem switches equipped for International Direct Distance Dialing to be arranged to forward the international calls of one or more international carriers to the customer (i.e., the Telephone Company is able to route originating international calls to a customer other than the one designated by the end user either through presubscription or 101XXXX dialing). This arrangement requires provision of written verification to the Telephone Company that the customer is authorized to forward such calls. The written verifications must be in the form of a letter of agency authorizing the customer to order the option on behalf of the international carrier. This option is only provided at Telephone Company end offices or access tandems equipped for International Direct Distance Dialing. It is available with ATA-101XXXX and FGD.

(S) Band Advance Arrangement for Use with WATS Access Line Service*

This option, which is provided in association with two or more WATS Access Line Services, provides for the automatic overflow of terminating calls to a WATS Access Line Service group, when that group has exceeded its call capacity, to another WATS Access Line Service group with a band designation equal to or greater than that of the overflowing WATS Access Line Service group. Band Advance will only be provided from one WATS Access Line Service group to another WATS Access Line Service group of the same IXC. This arrangement does not provide for call overflow from a group with a higher band designation to one with a lower one. This option is available with Access Arrangements and FGA, FGB, and FGD.

(D)

* This optional feature is not available with unbanded service, such as UWAL.

(This page filed under Transmittal No. 371)

Issued: September 6, 2007

Effective: September 22, 2007

Four AT&T Plaza, Dallas, Texas 75202

ACCESS SERVICE

6. Switched Access Service (Cont'd)6.3 Local Switching Optional Features and BSEs (Cont'd)6.3.1 Common Switching (Cont'd)(T) End Office End User Line Service Screening for Use with
Originating Only WATS Access Line Service

This option provides the ability to verify that an end user has dialed a called party address (by screening the called NPA and/or NXX on the basis of geographical bands selected by the Telephone Company) which is in accordance with that end user's service agreement with the customer, e.g., WATS. This option is provided in all Telephone Company end offices in which WATS Access Line Service is provided. It is available with ATA-101XXXX and FGD and in conjunction with a nonchargeable WATS Access Line Extension as set forth in 7.4.11 following.

(D)

(D)

(U) Hunt Group Arrangement for Use with WATS Access Line Service

This option provides the ability to sequentially access one of two or more WATS Access Line Services (e.g., 8yy Service access lines) in the terminating direction, when the hunting number of the WATS Access Line group is forwarded from the customer to the Telephone Company. This feature is provided in all Telephone Company end offices in which WATS Access Line Service is provided. It is available with Access Arrangements and FGA, FGB, and FGD.

(T)

(V) LATA-Wide Terminating Access

(D)

This option is available in LATAs that have more than one Telephone Company tandem. LATA-wide terminating access allows the customer to route terminating traffic to a Telephone Company designated tandem for access to NXX codes served by end offices that subtend Telephone Company tandems in the LATA. Terminating traffic outside of the Telephone Company designated entry tandem serving area will be routed over common transport trunk groups to the tandem serving the called area for completion. Telephone Company designated tandems are: LATA 1- SNFCCA2143T, LATA 2- RDNGCA0225T, LATA 5- LSANCA0470T, LATA 6- SNDGOCA0291T. It is available with ATA-950 and FGB.

(This page filed under Transmittal No. 371)

ACCESS SERVICE

6. Switched Access Service (Cont'd)6.3 Local Switching Optional Features and BSEs (Cont'd)6.3.1 Common Switching (Cont'd)(W) Uniform Call Distribution Arrangement for Use with WATS Access Line Service

This option provides a type of multiline hunting arrangement which provides for an even distribution of terminating calls among the available WATS Access Line Services in the hunt group. Where available, this feature is only provided in Telephone Company electronic end offices in which WATS Access Line Service is provided. It is available with Access Arrangements and FGA, FGB, and FGD.

(X) Nonhunting Number for Use with Hunt Group Arrangement or Uniform Call Distribution Arrangement for Use with WATS Access Line Service

(D)

This option provides an arrangement for an individual WATS Access Line Service within a multiline hunt or uniform call distribution group that provides access to that WATS Access Line Service within the hunt or uniform call distribution group when it is idle or provides busy tone when it is busy when the nonhunting number is dialed. Where available, this feature is only provided in Telephone Company electronic end offices in which WATS Access Line Service is provided. It is available with Access Arrangements, FGA, FGB, and FGD.

(D)

(This page filed under Transmittal No. 371)

ACCESS SERVICE

6. Switched Access Service (Cont'd)6.3 Local Switching Optional Features and BSEs (Cont'd)6.3.1 Common Switching (Cont'd)(Y) Public Switched Digital Service Access (PSDS)

This option allows for a connection between the customer's premises and a suitably equipped end user's premises utilizing end office switching capable of transmitting 56 Kbps digital data. In the originating direction, end users at suitably equipped end user premises can activate the capability in the end office switch by dialing #56 + 101XXXX + 7 or 10 digits or, when presubscribed to a participating interexchange carrier, #56 + 1 + 7 or 10 digits. In the terminating direction, the end office switch will signal the called party and place the terminal equipment in the digital mode. PSDS Access is available only with ATA-101XXXX and FGD and is only available in selectively equipped electronic end offices. This option is not available in combination with the CCSAC optional feature. Applicable rates can be found in 6.8.3 following.

(Z) Calling Party Number (CPN)

This option provides for the automatic transmission of the calling party's ten-digit telephone number to the customer's premises for calls originating in the LATA. The ten-digit telephone number consists of the NPA plus the seven-digit telephone number, which may or may not be the same as the calling station's charge number. The specific protocol for CPN is described in Pacific Bell Network Interface Specification Document PUB-L-780023-PB/NB and Bellcore Common Channel Signaling Network Specification Technical Reference TR-TSY-000905. This feature is available only with originating FGD and ATA-101XXXX when the CCSAC optional feature is specified.

(This page filed under Transmittal No. 1)

ACCESS SERVICE

6. Switched Access Service (Cont'd)6.3 Local Switching Optional Features and BSEs (Cont'd)6.3.1 Common Switching (Cont'd)(AA) Charge Number (CN)

This option provides for the automatic transmission of the ten-digit billing number of the calling station and originating line information. The specific protocol for CN is described in PUB-L-780023-PB/NB and Technical Reference TR-TSV-000905. This feature is available only with originating FGD and ATA-101XXXX when the CCSAC optional feature is specified. CN is the SS7 out of band signaling equivalent of ANI with multifrequency address signaling, as described in 6.3.1(F) preceding.

(AB) Carrier Selection Parameter (CSP)

This option provides for the automatic transmission of a signaling indicator which signifies to the customer whether the call being processed originated from a presubscribed end user of that customer. The specific protocol for CSP is described in PUB-L-780023 PB/NB and Technical Reference TR-TSV-000905. This feature is available only with originating FGD and ATA-101XXXX when the CCSAC optional feature is specified.

(AC) Hunt Group - C.O. Announcements

This option provides a delay announcement feature for automatic routing of incoming calls to multiline hunt groups to one or more pre-recorded announcements when the call is not serviced within a preset time interval. This option is available with ALA only and is associated with Uniform Call Distribution (UCD) with Queuing Arrangement. Where available, this feature is provided in Telephone Company electronic end offices only.

(This page filed under Transmittal No. 1)

ACCESS SERVICE

6. Switched Access Service (Cont'd)6.3 Local Switching Optional Features and BSEs (Cont'd)6.3.1 Common Switching (Cont'd)(AD) Hunt Group - Overflow

This option allows a call destined for the customer's hunt group to be routed to another telephone number within the same switching machine, but outside the hunt group. This option is available with ALA only and is associated with the Hunt Group Arrangement. Where available, this feature is provided in Telephone Company electronic end offices only.

(AE) Uniform Call Distribution (UCD) with Queuing

This option provides the capability for a UCD multiline hunt group to be equipped with the queuing feature. The queuing feature provides a means for automatically queuing a call to a multiline hunt group when all hunting group terminations are busy, the call is placed on queue and awaits its turn to be served. This option is available with ALA only and is associated with UCD Arrangement. Where available, this feature is provided in Telephone Company electronic end offices only.

(AF) Three Way Call Transfer

This option provides the customer who is on an established call with the ability to add another party to perform a three way conference. After establishing the conference, the customer may drop their connection without disconnecting the remaining two parties. This action allows the customer to transfer specific calls and free their line to initiate or receive another call. Charges between the originating locations and the ALA will be billed to the originating caller. The ALA transferring a call shall be responsible for the payment of all applicable charges including local, message unit, zone calling units, dial station toll and access arrangement usage charges. Where available, this feature is provided in Telephone Company electronic end offices only. This option is available with ALA only.

(This page filed under Transmittal No. 1)

ACCESS SERVICE

6. Switched Access Service (Cont'd)6.3 Local Switching Optional Features and BSEs (Cont'd)6.3.1 Common Switching (Cont'd)(AG) Answer Supervision - Lineside BSE

Answer supervision - lineside provides the capability to deliver "off-hook" supervisory signals from the terminating central office switch to a lineside interface at the originating central office switch. These signals indicate when the called station has answered an incoming call. Answer supervision will only be provided where technically feasible at the Telephone Companies electronic offices and is available with ALA service.

(AH) Make Busy Key - BSE

Make busy key transfer provides the ability to create a busy or overflow condition for a multiline hunt group. This option allows a customer to busy out a predetermined group of individual DID trunks and ALAs. The capability is activated by a customer provided key at the customer's premises. The activation signal is transmitted to the Telephone Company's central office with the use of a Type 1 DNAL as specified in Section 6.1.3(A) (7), preceding.

(T)

(This page filed under Transmittal No. 371)

Issued: September 6, 2007

Effective: September 22, 2007

Four AT&T Plaza, Dallas, Texas 75202

ACCESS SERVICE

6. Switched Access Service (Cont'd)6.3 Local Switching Optional Features and BSEs (Cont'd)6.3.1 Common Switching (Cont'd)(AI) Forwarded Call Information BSE

Forwarded Call Information (FCI) provides for the call status information of a call terminating on a ALA service with multiline hunt group arrangement. This option provides the calling number, called number, the identification of the called multiline hunt group assigned to the customer's end user, and the call reason. In addition, the option provides the ability to activate or deactivate a message waiting indicator audible (stutter dial tone) or message waiting indicator visual (signal light indicator). The message waiting indicator audible or visual, may be activated as long as the service where the message waiting indicator is to be activated is equipped with the message waiting feature. The Call status information is transmitted to the customer's premises and the signal to activate or deactivate the message waiting indicator is transmitted from the customer's message desk terminal equipment. The customer shall provide the appropriate customer premises equipment (CPE) to store, display or print out the transmitted call status information and the equipment to initiate the signal to activate or deactivate the message waiting indicator. This option is only available from appropriately equipped Telephone Company electronic end office switches. The forwarded call information is transmitted to the Telephone Company central office with the use of a Type 2 DNAL as specified in Section 6.1.3(A) (7), preceding. Message waiting indication capabilities are limited to customers who are served from the same office (intraoffice) as FCI.

(T)

(T) (N)
(N)
(N)

(This page filed under Transmittal No. 365)

ACCESS SERVICE

6. Switched Access Service (Cont'd)6.3 Local Switching Optional Features and BSEs (Cont'd)6.3.1 Common Switching (Cont'd)(AJ) Network Forwarded Call Information BSE

Network Forwarded Call Information (NFCI) provides for the call status information of a call terminating on a ALA service with multiline hunt group arrangement. This option provides the calling number, the called number, the identification of the called multiline hunt group assigned to the customer's end user, and the call reason. In addition, this option provides the ability to activate or deactivate a message waiting indicator audible (stutter dial tone) or message waiting indicator visual (signal light indicator). The message waiting indicator, audible or visual, may be activated as long as the service where the message waiting indicator is to be activated is equipped with the message waiting feature. The call status information is transmitted to the customer's premises, and the signal to activate or deactivate the message waiting indicator is transmitted from the customer's message desk terminal equipment. The customer shall provide the appropriate customer premises equipment (CPE) to store, display, or print out the transmitted call status information, and the equipment to initiate the signal to activate or deactivate the message waiting indicator. This option is only available from appropriately equipped Telephone Company electronic end office switches. The forwarded call information is transmitted to the Telephone Company central office with the use of a Type 2 DNAL, as specified in section 6.1.3.(A)(7). This BSE provides the ability to serve multiple offices using the SS7 signaling network to pass data and signaling information.

The Alternate Network Delivery (AND) feature provides the capability for the customer to direct its Message Waiting Indicator (MWI) messages toward the customer's Alternate Network Service Provider within the LATA. This feature is included with NFCI service.

Customers who upgrade their FCI service to NFCI or install a new NFCI service may elect to implement the AND feature at the time of the initial order request, or at a later date, at no additional recurring or nonrecurring charges.

(N)

(N)

(This page filed under Transmittal No. 365)

ACCESS SERVICE

6. Switched Access Service (Cont'd)6.3 Local Switching Optional Features and BSEs (Cont'd)6.3.1 Common Switching (Cont'd)(AJ) Network Forwarded Call Information BSE (Cont'd)

Customers subscribing to the AND feature must provide the Telephone Company with information specifying:

(1) The single pre-defined central office switch point code of the Alternate Network for the MWI messages to be routed.

(2) A list of all the alternate network provider's end user station NPA-NXXs receiving MWI messages (these must be served out of the same LATA as the Voice Grade Special Access Service - Technical Specification Package VG-10).

The customer's Alternate Network Service Provider must provide service capability to receive and complete MWI delivery. The customer is responsible for any and all charges that the Telephone Company may incur from the customer's Alternate Network Service Provider for receiving MWI messages from the Telephone Company.

Network Forwarded Call Information - Multiple Users provides the delivery of information on the calling number (within the same closed user group), called number, reason-for-forwarding of calls forwarded or placed to the Enhanced Service Provider (ESP), and identifies the multi-line hunt group assigned to the ESP end user, i.e., the multiple users capability. The reason-for-forwarding information may include when a line is busy, not answered, either busy or not answered, or used to call the ESP directly.

Network Forwarded Call Information - Multiple Users also includes the ability to activate and deactivate message waiting signals (audible or visual) on each of its end user's telephone line(s) who has Message Waiting Indicator. This alerting signal will be used by the ESP to inform its end user that information is waiting. The ESP end user lines must be provisioned to receive the signal and have Message Waiting Indicator provisioned with its line. A Special Access Voice Grade (VG36) channel is required between the ESP and the Utility's central office in order to meet the data communications requirements in providing Forwarded Call Information - Multiple Users to the end user. Numbers will be provided in either seven (7) or ten (10) digit format. The customer must specify the number of digits.

(This page filed under Transmittal No. 365)

(N)

(N)

ACCESS SERVICE

6. Switched Access Service (Cont'd)6.3 Local Switching Optional Features and BSEs (Cont'd)6.3.1 Common Switching (Cont'd)(AK) Activate Message Waiting Indicator-Audible

Activate Message Waiting Indicator-Audible provides the ability to activate or deactivate a message waiting indicator audible (stutter dial tone) on a customer's end user's service. The Message Waiting Indicator-Audible may be activated as long as the customer's end user's line is also provisioned with the message waiting indicator message waiting indicator is feature. The signal to activate or deactivate the transmitted from the customer's message desk terminal equipment. The customer shall provide the appropriate CPE to initiate the signal to activate or deactivate the message waiting indicator. This option is only available from appropriately equipped Telephone Company electronic end office switches. The message waiting indicator is transmitted to the Telephone Company central office with the use of a Type 2 DNAL, as specified in Section 6.1.3(A) (7), preceding.

(T)

(T)

(This page filed under Transmittal No. 365)

Issued: August 13, 2007

Effective: August 28, 2007

Four AT&T Plaza, Dallas, Texas 75202

ACCESS SERVICE

6. Switched Access Service (Cont'd)6.3 Local Switching Optional Features and BSEs (Cont'd)6.3.1 Common Switching (Cont'd)(AL) Activate Message Waiting Indicator-Visual

Activate Message Waiting Indicator-Visual provides the ability to activate or deactivate a lamp or LCD flash at 60 IPM on a customer's end user's service when there are messages waiting. The Message Waiting Indicator-Visual may be activated as long as the customer's end user's service is equipped with the message waiting indicator feature. The signal to activate or deactivate the message waiting indicator is transmitted from the customer's message desk terminal equipment. The customer shall provide the appropriate CPE to initiate the signal to activate or deactivate the message waiting indicator. A customer's lamp or LCD is activated on their CPE when a signal is sent to the central office to apply 130 volts to the customer lamp. An additional signal would be sent after the messages have been retrieved to remove the 130 volts from the lamp. This option is only available from appropriately equipped Telephone Company electronic end office switches. The message waiting indicator is transmitted to the Telephone Company central office with the use of a Type 2 DNAL as specified in 6.1.3(A) (7), preceding.

(T)

(AM) Access Transport Parameter (ATP)

This optional feature provides for the transmission of ISDN/SS7 call set up information from the originating switch to the customer's premises and, on terminating access, from the customer's premises to the terminating switch.

(T)

(T)

This optional feature is available only with FGD with CCSAC where technical capabilities exist. The specific protocol for ATP is as specified in Technical Reference TR-TSV-000962.

(This page filed under Transmittal No. 365)

ACCESS SERVICE

6. Switched Access Service (Cont'd)6.3 Local Switching Optional Features and BSEs (Cont'd)6.3.1 Common Switching (Cont'd)(AN) Calling Number Delivery via ICLID

This Option provides for the automatic transmission of the calling party's ten-digit telephone number to the customer's premises via the Basic Serving Element (BSE) feature Individual Calling Line Identification (ICLID). This feature is available only with the ALA. The ten-digit telephone number consists of the NPA plus the seven-digit telephone number which may or may not be the same as the calling station's charge number. Calling parties will have the ability to block the sending of their telephone numbers. If the calling party chooses to block delivery of their telephone number, the number will not be sent from the terminating end-office to the customer's premises. Calling party telephone numbers may not be delivered to the customers end office on all calls. When the calling party number is not delivered to the end office, the calling number will not be delivered to the customer.

(T)

(This page filed under Transmittal No. 365)

Issued: August 13, 2007

Effective: August 28, 2007

Four AT&T Plaza, Dallas, Texas 75202

ACCESS SERVICE

6. Switched Access Service (Cont'd)6.3 Local Switching Optional Features and BSEs (Cont'd)6.3.2 Transport Termination(A) Rotary-Dial Station Signaling

This option provides for the transmission of called party address signaling from rotary dial stations to the customer's premises for originating calls. This option is provided in the form of a specific type of Transport Termination. It is available with ATA-950 and FGB, only on a directly trunked basis.

(B) Operator Trunk - Modified Operator Services (MOS) - Coin, Non-Coin, or Combined Coin and Non-Coin

This option may be ordered to provide coin, non-coin, or combined coin and non-coin operation. It is available with ATA-101XXXX and FGD and is provided in end offices where equipment is available. It is provided as a trunk type of Transport Termination.

(D)

Coin:

This arrangement provides for initial coin return control and routing of 0+, 0-, 1+, 01+, or 011+ prefixed originating coin calls requiring operator assistance to the customer's premises. Because operator assisted coin calling traffic is routed over a trunk group dedicated to operator assisted calls, this arrangement is only provided in association with the Service Class Routing option.

(This page filed under Transmittal No. 371)

ACCESS SERVICE

6. Switched Access Service (Cont'd)6.3 Local Switching Optional Features and BSEs (Cont'd)6.3.2 Transport Termination (Cont'd)(B) Operator Trunk - Modified Operator Services (MOS) - Coin, Non-Coin, or Combined Coin and Non-Coin (Cont'd)

Coin: (Cont'd)

The operator assistance coin calling arrangement is also normally ordered by the customer in conjunction with the ANI optional feature, the trunk groups equipped with this arrangement will be terminated at the customer's specified location.

Non-Coin:

This arrangement provides for the routing of 0+, 0-, 1+, 01+ or 011+ prefixed originating non-coin calls requiring operator assistance to the customer's premises. Because operator assisted non-coin calling traffic is routed over a trunk group dedicated to operator assisted calls, this arrangement is only provided in association with the Service Class Routing option.

The operator assistance non-coin calling arrangement is also normally ordered by the customer in conjunction with the ANI optional feature, the trunk groups equipped with this arrangement will be terminated at the customer's specified location. When so equipped, the ANI feature provides for the forwarding of information digits which identify that the call has originated from a hotel or motel, and whether room number identification is required or that special screening is required, e.g., for coinless public stations, dormitory or inmate stations, or other screening arrangements agreed to between the customer and the Telephone Company.

(This page filed under Transmittal No. 1)

ACCESS SERVICE

6. Switched Access Service (Cont'd)6.3 Local Switching Optional Features and BSEs (Cont'd)6.3.2 Transport Termination (Cont'd)(B) Operator Trunk - Modified Operator Services (MOS) - Coin, Non-Coin, or Combined Coin and Non-Coin (Cont'd)

Combined Coin and Non-Coin:

This arrangement provides for initial coin return control and routing of 0+, 0-, 1+, 01+ or 011+ prefixed originating operator-assisted coin and non-coin calls requiring operator assistance to the customer's premises. Because operator-assisted coin and non-coin-calling traffic is routed over a trunk group dedicated to operator assisted calls, this arrangement is only provided in association with the Service Class Routing option.

This arrangement is normally ordered by the customer in conjunction with the ANI optional feature, the trunk groups equipped with this arrangement will be terminated at the customer's specified location. When so equipped, the ANI optional feature provides for the forwarding of information digits which identify that the call has originated from a hotel or motel, and whether room-number identification is required, or that special screening is required, e.g., for coinless pay telephone stations, dormitory or inmate stations, or other screening arrangements agreed to between the customer and the Telephone Company.

This option provides the operator functions available in the end office to the customer's specified location. These functions are (1) Operator Release, (2) Operator Attached, (3) Coin Collect, (4) Coin Return, and (5) Ringback. It is available from the Telephone Company's end office to the customer's specified location. This option is not available in combination with the CCSAC optional feature.

(C)

(This page filed under Transmittal No. 517)

ACCESS SERVICE

6. Switched Access Service (Cont'd)

6.3 Local Switching Optional Features and BSEs (Cont'd)

6.3.2 Transport Termination (Cont'd)

(C) Operator Trunk - Exchange Access Operator Services System
(EAOSS)

This option provides the operator functions available in the end office to the customer. These functions are (1) Operator Released, (2) Operator Attached, (3) Coin Collect, (4) Coin Return, and (5) Ringback. It is available with ATA-101XXXX and FGD and is provided as a trunk type of Transport Termination from the Telephone Company's coin tandem or direct from the end office to the customer's specified location, where technically feasible.

(C)

(This page filed under Transmittal No. 517)

ACCESS SERVICE

6. Switched Access Service (Cont'd)6.3 Local Switching Optional Features and BSEs (Cont'd)6.3.3 WATS Access Line Termination

The WATS Access Line Terminations are differentiated by line side vs. trunk side terminations. The standard WATS Access Line Arrangement is available with a line side termination. There are various types of originating, terminating and two way line side terminations depending on the type of signaling associated with the WATS Access Line. (i.e., loop start or ground start). Line side terminations are available with either dial pulse or dual tone multifrequency address signaling.

Available nonchargeable line side and trunk side terminations can be found in Technical Reference TR-NPL-000334.

In addition, there are also various types of originating, terminating and two way WATS Access Line trunk side terminations that are available in lieu of standard line side terminations. Trunk side terminations are provided only in association with digital (i.e., DS1) WATS Access Line Service or with certain Line Termination optional features as specified following:

(A) Line Termination Optional Features for Trunk-Side Connections

The Telephone Company will, at the option of the customer, provide the following line termination optional features in association with WATS Access Line Service.

(1) E&M Supervisory Signaling

The E&M Supervisory Signaling optional feature, which is available with four-wire originating and terminating WATS Access Lines, provides for E&M Type 1, Type 2 or Type 3 Supervisory Signaling in lieu of loop start or ground start Supervisory Signaling.

(This page filed under Transmittal No. 1)

ACCESS SERVICE

6. Switched Access Service (Cont'd)

6.3 Local Switching Optional Features and BSEs (Cont'd)

6.3.3 WATS Access Line Termination (Cont'd)

(A) (Cont'd)

(2) Dialed Number Identification Service (DNIS)

(T)

The Dialed Number Identification Service optional feature, which is available with terminating only WATS Access Lines, permits a customer's End User with multiple Toll Free Service telephone numbers in the same service group to identify the specific Toll Free 8yy type number which was dialed by the calling party. Four digits which identify the dialed Toll Free 8yy type number are outpulsed to the customer premises equipment at the end user premises. The digits are outpulsed over the WATS Access Lines. All WATS Access Lines in the same service group must be equipped for DNIS. For each dialable Toll Free 8yy type number there must be at least one WATS Access Line in the service group. DNIS is provided with reverse battery type supervisory signaling.

(T)

(T)

(T)

(T)

(T)

(This page filed under Transmittal No. 371)

ACCESS SERVICE

6. Switched Access Service (Cont'd)6.4 Transmission Specifications

Each Switched Access Service transmission path is provided with standard transmission specifications. There are three different standard specifications (Types A, B and C). The standard for a particular transmission path is dependent on the Feature Group or Access Arrangements, the Interface Group and whether the service is directly routed or via an access tandem. The available transmission specifications are set forth in Technical References TR-NPL-000334 and Pacific Bell's Appendix to TR-NWT-000334, PUB L-786250. Acceptance limits, maintenance limits and immediate action limits are provided by either Technical References TR-NWT-000334 or PUB L-786250. Where conflicts are encountered, the Telephone Company's standards apply. Where limits are specific to a particular facility, those limits apply to those facilities available and assigned to the customer for Access Service. Data Transmission Parameters are also provided with each Switched Access Service transmission path. The Telephone Company will, upon notification by the customer that the data parameters set forth in Technical References TR-NWT-000334 and PUB L-786250 are not being met, conduct tests independently or in cooperation with the customer, and take any necessary action to insure that the parameters are met.

The Telephone Company will maintain existing transmission specifications on functioning service configurations installed prior to the effective date of this tariff except that service configurations having performance specifications exceeding the standards listed in this provision will be maintained at performance levels specified in this tariff.

Transmission specifications for SS7 Signaling Connections are set forth in PUB-L-780023-PB/NB and Technical Reference TR-TSY-000905.

Transmission specifications for FGD with the 64 CCC optional feature are set forth in Technical Reference TR-NWT-000938.

(This page filed under Transmittal No. 1)

ACCESS SERVICE

6. Switched Access Service (Cont'd)

6.5 Obligations of the Telephone Company

In addition to the obligations of the Telephone Company set forth in 2. preceding, the Telephone Company has certain other obligations pertaining only to the provision of Switched Access Service. These obligations are as follows:

6.5.1 Network Management

The Telephone Company will administer its network to insure the provision of acceptable service levels to all telecommunications users of the Telephone Company's network services. Generally, service levels are considered acceptable only when both end users and customers are able to establish connections with little or no delay encountered within the Telephone Company network. The Telephone Company maintains the right to apply protective controls, i.e., those actions, such as call gapping, which selectively restrict the completion of traffic, over any traffic carried over its network, including that associated with a customer's Switched Access Service. Generally, such protective measures would only be to minimize the impact of occurrences such as failure or overload of Telephone Company or customer facilities, natural disasters, mass calling or national security demands. In the event that the protective controls applied by the Telephone Company result in the complete loss of service by the customer, the customer will be granted a Credit Allowance for Service Interruption as set forth in 2.4.4.(B)(3) preceding.

(Dx)
|
(Dx)

The Telephone Company SS7 signaling network will provide management functions as described in detail in PUB-L-780023-PB/NB and Technical Reference TR-TSV-000905.

(x) Issued under authority of Special Permission No. 13-019 of the FCC in order to withdraw material filed under Transmittal No. 492 without its becoming effective and to restore currently effective material.

(This page filed under Transmittal No. 493)

ACCESS SERVICE

6. Switched Access Service (Cont'd)

6.5 Obligations of the Telephone Company (Cont'd)

6.5.2 Reserved for Future Use

(T)

(D)

(D)

(This page filed under Transmittal No. 550)

Issued: January 24, 2017

Effective: February 8, 2017

675 W. Peachtree St. NW, Atlanta, GA 30308

ACCESS SERVICE

6. Switched Access Service (Cont'd)6.5 Obligations of the Telephone Company (Cont'd)6.5.3 Trunk Group Measurements Report

Subject to availability, the Telephone Company will make available trunk group data in the form of usage in Hundred Call Seconds (CCS), peg count and overflow, and will provide it to the customer at agreed to intervals.

Upon specific customer requests for reports other than those on previously agreed to intervals where manual processes are required to provide the trunk group data, charges as set forth in 13.3.9 (National Traffic Data Special Requests) following are applicable.

(This page filed under Transmittal No. 1)

Issued: April 27, 2000

Effective: May 12, 2000

Four AT&T Plaza, Dallas, Texas 75202

ACCESS SERVICE

6. Switched Access Service (Cont'd)6.5 Obligations of the Telephone Company (Cont'd)

6.5.4

6.5.5

6.5.6 Design Blocking Probability

The Telephone Company will cooperate in the design of the number of the facilities used in the provision of Switched Access Service. The Telephone Company will monitor the facilities used in the provision of Switched Access Service to meet the blocking probability criteria as set forth in (A) through (F) following.

(This page filed under Transmittal No. 1)

Issued: April 27, 2000

Effective: May 12, 2000

Four AT&T Plaza, Dallas, Texas 75202

ACCESS SERVICE

6. Switched Access Service (Cont'd)

6.5 Obligations of the Telephone Company (Cont'd)

6.5.6 Design Blocking Probability (Cont'd)

(A) For ALA, FGA and FGB, no design blocking criteria apply.

(B)

(D)



(D)

(C) For ATA-101XXXX and FGD, the design blocking objective for the final group will be no greater than one percent (.01) between the point of termination at the customer's premises and the end office switch, whether the traffic is directly routed without an alternate route or routed via an access tandem. Standard traffic engineering methods as set forth in PUB TR EOP-000178 Trunk Traffic Engineering Concepts and Applications (Chapters 6-7) will be used by the Telephone Company to determine the number of transmission paths required to achieve this level of blocking.

(D) For Entrance Facilities no design blocking criteria apply. For Direct Trunked Transport used in provision of ALA, ATA-950, FGA and FGB, no design blocking criteria apply. For Direct Trunked Transport used in provision of ATA-101XXXX and FGD, the design blocking objective is the same as for the ATA-101XXXX or FGD using the facility. For Tandem Switched Facility, the design blocking objective is the same as for the ALA, ATA or Feature Groups using the facility.

(This page filed under Transmittal No. 489)

ACCESS SERVICE

6. Switched Access Service (Cont'd)

6.5 Obligations of the Telephone Company (Cont'd)

6.5.6 Design Blocking Probability (Cont'd)

(E)

The design blocking criteria for 500, 8yy or 900 Access Service provided from an end office will be equivalent to that set forth preceding for ATA-101XXXX and FGD except when more than one tandem is employed in the transport of an 8yy Access Service call. For 900 Access Service, where trunk access limitation as set forth in 6.3.1(P) is applicable design blocking criteria does not apply.

(D)
(D)
(D)
(D)
(T)
(D)
(T)

(F) The Telephone Company will perform routine measurement functions for the capacity ordered, to assure that an adequate number of transmission paths are in service. The Telephone Company will recommend that additional capacity (i.e., trunks) be ordered by the customer when additional paths are required to reduce the measured blocking level. For ATA-101XXXX or FGD capacity ordered, the design blocking objective is assumed to have been met if the routine measurements show that the measured blocking does not exceed the threshold listed in the following tables.

(D)

(1) For transmission paths carrying only first routed traffic directly between an end office and customer's premises without an alternate route, and for paths carrying only overflow traffic, the measured blocking thresholds are as follows:

(This page filed under Transmittal No. 371)

ACCESS SERVICE

6. Switched Access Service (Cont'd)

6.5 Obligations of the Telephone Company (Cont'd)

6.5.6 Design Blocking Probability (Cont'd)

(F) (Cont'd)

(1) (Cont'd)

Engineering Objective = 1% Blocking (.010)

Measured Blocking Thresholds

in the Time Consistent Busy Hour

Number of
Transmission Paths
Per Trunk Group

	Per Trunk Group			
	15-20 Days of Valid Data	11-14 Days of Valid Data	7-10 Days of Valid Data	3-6 Days of Valid Data
2	.070	.080	.090	.140
3	.050	.060	.070	.090
4	.050	.060	.070	.080
5-6	.040	.050	.060	.070
7 or more	.030	.035	.040	.060

(2) For transmission paths carrying first-routed traffic between an end office and an access tandem or between an access tandem and customer's premises, the measured blocking thresholds are as follows:

Engineering Objective = .5% Blocking (.005)

Measured Blocking Thresholds

in the Time Consistent Busy Hour

Number of
Transmission Paths
Per Trunk Group

	Per Trunk Group			
	15-20 Days of Valid Data	11-14 Days of Valid Data	7-10 Days of Valid Data	3-6 Days of Valid Data
2	.045	.055	.060	.095
3	.035	.040	.045	.060
4	.035	.040	.045	.055
5-6	.025	.035	.040	.045
7 or more	.020	.025	.030	.040

(This page filed under Transmittal No. 1)

ACCESS SERVICE

6. Switched Access Service (Cont'd)6.5 Obligations of the Telephone Company (Cont'd)6.5.7 Provision of Service Performance Data

Subject to availability, end-to-end service performance data available to the Telephone Company through its own service evaluation routines, may also be made available to the customer based on previously arranged intervals and format. These data provide information on overall end-to-end call completion and non-completion performance, e.g., customer equipment blockage, failure results and transmission performance. These data do not include service performance data which are provided under other tariff sections, e.g., testing service results. If data are to be provided in other than paper format, the charges for such exchange will be determined on an individual case basis.

(This page filed under Transmittal No. 1)

Issued: April 27, 2000

Effective: May 12, 2000

Four AT&T Plaza, Dallas, Texas 75202

ACCESS SERVICE

6. Switched Access Service (Cont'd)6.6 Obligations of the Customer

In addition to the obligations of the customer set forth in 2. preceding, the customer has certain specific obligations pertaining to the use of Switched Access Service. These obligations are as follows:

6.6.1 Report Requirements

Customers are responsible for providing the following reports to the Telephone Company, when applicable.

(A) Jurisdictional Reports

When a customer orders Switched Access Service for both interstate and intrastate use, the customer is responsible for providing reports as set forth in 2.3.14 (Jurisdictional Report Requirements) preceding. Charges will be apportioned in accordance with those reports. The method to be used for determining the interstate charges is set forth in 2.3.15 (Determination of Interstate and Intrastate Access Service) preceding.

(B) Code Screening Reports

When a customer orders service class routing, trunk access limitation or call gapping arrangements, it must report the number of trunks and/or the appropriate codes to be instituted in each end office or access tandem switch, for each of the arrangements ordered.

(C) 900 Access Service Code Reports

When ordering 900 Access Service, the customer must report the appropriate NXX Codes to be instituted. The Telephone Company will activate code identification at all offices where capability is available. The report must be updated by the customer each time a change is scheduled to occur, i.e., when a new code is to be added or an existing code is to be deleted. Such reports shall be provided according to negotiated service intervals in order to allow the Telephone Company sufficient time to implement the change.

(This page filed under Transmittal No. 1)

ACCESS SERVICE

6. Switched Access Service (Cont'd)6.6 Obligations of the Customer (Cont'd)6.6.1 Report Requirements (Cont'd)(D) Substantial Call Volume 900 Services

When a customer offers services for which a substantial call volume is expected during a short period of time (e.g. media stimulated events) the customer must notify the Telephone Company at least 24 hours in advance of each peak period. For events scheduled during weekends or holidays, the Telephone Company must be notified no later than 5:00 p.m. local time the prior business day. Notification should include the nature, time, duration and frequency of the event, an estimated call volume, and the 900 NXX line number(s) to be used.

On the basis of the information provided, the Telephone Company will work cooperatively with the customer to implement network management controls if required to reduce the probability of excessive network congestion. The Telephone Company will also work cooperatively with the customer to determine the appropriate level of such control.

Failure to provide prescribed notification may result in customer caused network congestion, which could result in discontinuation of service under 2.1.8 (Refusal and Discontinuance of Service) and/or damages under 2.1.3 (Liability).

6.6.2 Supervisory Signaling

The customer facilities shall provide the necessary on-hook, off-hook answer and disconnect supervision.

(This page filed under Transmittal No. 1)

ACCESS SERVICE

6. Switched Access Service (Cont'd)6.6 Obligations of the Customer (Cont'd)6.6.3 CCSAC Measurement Data

The customer must provide the Telephone Company with the types of utilization, screening results and maintenance that are being made on SS7 Signaling Connections. The above information must be shared with the Telephone Company on an ongoing basis in order to provide capacity to transport and process interconnecting traffic. Requirements are described in PUB-L-780023-PB/NB.

6.6.4 Trunk Group Measurements Reports

With the agreement of the customer, trunk group data in the form of usage in CCS, peg count and overflow for its end of the Telephone Company's access trunk groups, where technologically feasible, will be made available to the Telephone Company. These data will be used to monitor trunk group utilization and service performance and will be based on previously arranged intervals and format.

(C)
(T)6.6.5 Design of Switched Access Services

When a customer orders Switched Access Service, it is the customer's responsibility to assure that sufficient access services have been ordered to handle its traffic.

6.6.6 Outbound Messaging Application

The Outbound Messaging Application customer is responsible for the delivery of signaling messages associated with Message Waiting from a Customer Designated Message Waiting Service (e.g.: Voice Mail Provider) to the Telephone Company's SS7 signaling network

The Outbound Messaging Application customer is responsible for the connectivity of the Customer Designated Message Waiting Service (e.g.: Voice Mail Provider) for use with the Outbound Messaging Application.

The Outbound Messaging Application customer is responsible for ensuring the accuracy and timeliness of Message Waiting signals sent from the Customer's Designated Message Waiting Service (e.g.: Voice Mail Provider).

(This page filed under Transmittal No. 371)

ACCESS SERVICE

6. Switched Access Service (Cont'd)6.7 Rate Regulations

This section contains the specific regulations governing the rates and charges that apply for Switched Access Service.

6.7.1 Description and Application of Rates and Charges

There are three types of rates and charges that apply to Switched Access Service. These are monthly recurring rates (including fixed and per mile rates), usage rates (including fixed and per mile rates) and nonrecurring charges. These rates and charges are applied differently to the various rate elements.

(A) Monthly Rates

(D)

Monthly rates (including, but not limited to, fixed and per mile rates) are flat recurring rates that apply each month or fraction thereof that a specific rate element is provided. For billing purposes, each month is considered to have 30 days.

(C)

(B) Usage Rates

Usage rates (for usage generated by or to each line or trunk) are rates that apply on a per unit basis (e.g. per call, per access minute or per minute per mile or per query) when a specific rate element is used. Usage charges are accumulated over a monthly period.

(C)

(C)

(This page filed under Transmittal No. 371)

ACCESS SERVICE

6. Switched Access Service (Cont'd)

6.7 Rate Regulations (Cont'd)

6.7.1 Description and Application of Rates and Charges (Cont'd)

(C) Nonrecurring Charges*

Nonrecurring charges are one time charges that apply for a specific work activity (i.e., installation or change to an existing service). The types of nonrecurring charges that apply for Switched Access Service are: installation of service, and service rearrangements.

(1) Installation of Service

Nonrecurring charges apply to each Switched Access service installed and will include charges for Entrance Facility and lines or trunks that traverse Direct Trunked Transport for the termination in an end office or an access tandem. In addition, nonrecurring charges apply when an SS7 signaling Connection is installed for use with FGD or ATA-101XXXX with the CCSAC optional feature or for LIDB Service.

(D)
(C)

(a) For an Entrance Facility which is ordered on a per transport channel basis, e.g., VG, DS1 or DS3, the charge is applied per transport channel.

(T)
(T)

(b) For Switched Access lines or trunks which traverse Direct Trunked Transport for the termination in an end office or an access tandem, the nonrecurring charge (USOC TPP++) is applied per line or trunk basis.

(D)
(C)
(C)
(C)

For other optional features or Basic Service Elements (BSEs), a nonrecurring charge applies per arrangement as shown in 6.8 following.

* For Services ordered under MVP, refer to Section 22.3 (E) (5).

(This page filed under Transmittal No. 361)

ACCESS SERVICE

6. Switched Access Service (Cont'd)6.7 Rate Regulations (Cont'd)6.7.1 Description and Application of Rates and Charges (Cont'd)(C) Nonrecurring Charges* (Cont'd)

(C)

(1) Installation of Service (Cont'd)

Certain Switched Access Services have a first and additional nonrecurring charge rate structure that will be treated as follows: When multiple identical services (i.e., services between the same locations and for the same customer) are ordered and installed, moved or rearranged at the same time, there is a charge for the first service installed and a lower charge for each additional identical service installed.

The services for which first and additional nonrecurring charges apply and their rates are shown in 6.8 following.

(2) Service Rearrangements

Changes which are considered to be service rearrangements are as set forth in 5.2.8 (Service Rearrangements) preceding.

Administrative changes will be made without charge except as set forth in 5.2.8 (Services Rearrangements) preceding.

- If the change involves the addition of or a modification to an optional feature which has a separate nonrecurring charge, that nonrecurring charge will apply.

-On existing Switched Access trunks, for a change of Switched Access signaling type from multifrequency address signaling to SS7 out of band signaling, i.e., the CCSAC optional feature, no charge will apply, provided there is no change in the physical serving arrangement. When the CCSAC optional feature is specified, the customer may add Calling Party Number (CPN), Charge Number (CN), Carrier Selection Parameter (CSP) and Access Transport Parameter (ATP) at no charge if these optional features are specified at the same time the CCSAC optional feature is ordered.

* For Services ordered under MVP, refer to Section 22.3 (E) (5).

(This page filed under Transmittal No. 25)

(C)

ACCESS SERVICE

6. Switched Access Service (Cont'd)

6.7 Rate Regulations (Cont'd)

6.7.1 Description and Application of Rates and Charges (Cont'd)

(C) Nonrecurring Charges* (Cont'd)

(2) Service Rearrangements (Cont'd)

For all other Switched Access changes, including the addition of, or modifications to, optional features without separate nonrecurring charges, a charge equal to one half the Switched Transport nonrecurring (i.e., USOC TPP++) charge will apply. When an optional feature is not required on each line or trunk, but rather for an entire line or trunk group, an end office or an access tandem switch, only one such charge will apply (i.e., it will not apply per line or trunk).

(C)
(C)
(C)

(C)

(D)

|

(D)

* For Services ordered under MVP, refer to Section 22.3 (E) (5).

(This page filed under Transmittal No. 361)

ACCESS SERVICE

6. Switched Access Service (Cont'd)

6.7 Rate Regulations (Cont'd)

6.7.1 Description and Application of Rates and Charges (Cont'd)

(D) Application of Rates

Switched Transport, Local Switching, and the Information
Surcharge rates are applied as premium rates.

Premium rates apply to all ATA-101XXXX and FGD access
minutes. Premium rates also apply to all ALA, FGA, FGB, ATA-
950, 500 and all Toll Free Access Service access minutes that
originate from or terminate at end offices.

(C)

(This page filed under Transmittal No. 517)

ACCESS SERVICE

6. Switched Access Service (Cont'd)

6.7 Rate Regulations (Cont'd)

6.7.1 Description and Application of Rates and Charges (Cont'd)

(D) Application of Rates (Cont'd)

The following paragraphs set forth the Switched Access Service rate elements and how the rates are applied to the elements.

(T)

(1) Entrance Facilities

The Entrance Facility includes the charge for transport from a customer's service wire center to the customer's premises. The rate is applied for a Voice Grade, DS1 and DS3 Transport Channel on a point of termination per month basis. The rate as set forth in 6.8.2(A) following applies for the selected Transport Channel per point of termination even if all the transmission paths on the selected Transport Channel are not activated. The DS3 Entrance Facility requires DS3 to DS1 multiplexing as set forth in 6.8.2(K) (2), following. Additionally, a DS1 to DS0/VG multiplexing chargeable optional feature is available as set forth in 6.8.2(K) (2), following.

(T)

(2) Direct Trunked Transport

Direct Trunked Transport includes the charge for transport from a customer's serving wire center to an end office for switching of a customer's originating and terminating traffic, a hub location for multiplexing or an access tandem for interconnection to Tandem Switched Transport to an end office(s). Direct Trunked Transport also includes charges between hub locations or from a hub location to an end office or to an access tandem. The rates are applied for a Voice Grade, DS1 and DS3 Transport Channel on a per month fixed and per month per mile basis. The mileage between the end office, hub or access tandem involved and the customer's serving wire center is determined as set forth in 6.7.13, following. The rates as set forth in 6.8.2(B), following, apply for the selected Transport Channel even if all the transmission paths on the selected Transport Channel are not activated. Multiplexing is required when the capacity, VG, DS1, DS3 is different between the Entrance Facility and the Direct Trunked Transport, or between Direct Trunked Transport at a hub and Direct Trunked Transport to an end office or access tandem. DS3 Direct Trunked Transport requires DS3 to DS1 multiplexing as set forth in 6.8.2(K) (2), following. Additionally, a DS1 to DS0/VG multiplexing chargeable optional feature is available as set forth in 6.8.2(K) (2), following.

(T)

(N)

(N)

(N)

(T)

(N)

(N)

(N)

(N)

(N)

(T)

(T)

(This page filed under Transmittal No. 371)

ACCESS SERVICE

6. Switched Access Service (Cont'd)6.7 Rate Regulations (Cont'd)6.7.1 Description and Application of Rates and Charges (Cont'd)(D) Application of Rates (Cont'd)(3) Tandem Switched Transport

Tandem Switched Transport includes charges for transport from end offices to the access tandem, Tandem End Office Multiplexing and for Tandem Switching at the access tandem.

- (a) Tandem Switched Transmission rates are applied on a per minute of use fixed and per minute of use per mile basis. The chargeable minutes of use for determining the charges are the minutes that are carried over the involved Tandem Switched Transport facilities. The mileage between the end office involved and the access tandem is determined as set forth in 6.7.13, following. The rates are as set forth in 6.8.2(C), following.

Tandem Switched Transmission rate elements are billed as (N)
Originating, Terminating to Telephone Company's own end office, (N)
and Terminating to non-Telephone Company 3rd party locations (N)
based on call recordings. Non-Telephone Company 3rd party (N)
locations are all offices or other locations not owned by the (N)
Telephone Company. Examples of 3rd party locations include (N)
terminations to other local exchange and wireless carriers. (N)

- (b) Tandem Switching and Tandem End Office Multiplexing rates are applied on a per minute of use basis. The chargeable minutes of use for determining the charges are the minutes that are carried over the involved Tandem Switched Transport facilities. The chargeable minutes are determined as set forth in 6.7.8 following. The rates are as set forth in 6.8.2(C) following.

Tandem Switching and Tandem End Office Multiplexing rate (N)
elements are billed as Originating, Terminating to Telephone (N)
Company's own end office, and Terminating to non-Telephone (N)
Company 3rd party locations based on call recordings. Non- (N)
Telephone Company 3rd party locations are all offices or other (N)
locations not owned by the Telephone Company. Examples of 3rd (N)
party locations include terminations to other local exchange (N)
and wireless carriers. (N)

(This page filed under Transmittal No. 552)

ACCESS SERVICE

6. Switched Access Service (Cont'd)

6.7 Rate Regulations (Cont'd)

6.7.1 Description and Application of Rates and Charges (Cont'd)

(D) Application of Rates (Cont'd)

(3) Tandem Switched Transport (Cont'd)

(c) Host Remote Transmission

A per access minute of use and a per access minute of use per mile rate applies between the Host and the remote for the common use of all customers between a host office and the remote switching system or remote switching module where the call originates or terminates.

Mileage is always measured separately from Tandem Switched Transmission and Direct Trunked Transport.

Mileage measurement is described in 6.7.13 (Determining Switched Transport Mileage and Charges).

- (d) Dedicated Tandem Trunk Port is billed as originating and terminating based on a Percent Originating Usage (POU) factor of 50%. (C)

Originating Calculation = PIU x Originating Rate x Quantity x POU
Terminating Calculation = PIU x Terminating Rate x Quantity x (100-POU)

(C)
|
(C)

(This page filed under Transmittal No. 488)

ACCESS SERVICE

6. Switched Access Service (Cont'd)

6.7 Rate Regulations (Cont'd)

6.7.1 Description and Application of Rates and Charges (Cont'd)

(D) Application of Rates (Cont'd)

(4) Multiplexing

The Multiplexing rate applies when an Entrance Facility or Direct Trunked Transport is multiplexed at a Telephone Company hub to a lower capacity (i.e., DS3 to DS1 or DS1 to DS0/VG). A Multiplexing charge will also apply when facilities of one capacity are connected to facilities of another capacity. DS3 to DS1 multiplexing is required on a DS3 Entrance Facility or Direct Trunked Transport. The Multiplexing rate is applied on a per multiplexing arrangement basis. The rate as set forth in 6.8.2(E) following applies for the selected multiplexing arrangement even if all the multiplexing ports for the selected multiplexing arrangement are not activated.

(T)

(N)
(N)
(N)

(This page filed under Transmittal No. 371)

ACCESS SERVICE

6. Switched Access Service (Cont'd)

6.7 Rate Regulations (Cont'd)

6.7.1 Description and Application of Rates and Charges (Cont'd)

(D) Application of Rates (Cont'd)

(5) Local Switching

Local Switching includes usage charges, monthly recurring charges, and optional features charges. Local Switching usage's rates are applied on a per minute of use basis. Premium rates apply. The chargeable minutes are determined as set forth in 6.7.8 following. The rates are as set forth in 6.8.3 and 6.8.5 following.

Local Switching optional feature rates are applied on a per month and a per minute of use basis as set forth in 6.8.3 and 6.8.5 following.

(a) Dedicated End Office Port

The Dedicated End Office Port provides for each dedicated line or trunk terminating in the end office port.

A monthly rate applies, per line or per trunk for each in service dedicated line or trunk terminating in the end office port. The rate is set forth in 6.8.3(B), following.

Dedicated End Office Port is billed as originating and terminating based on a Percent Originating Usage (POU) factor of 50%.

Originating Calculation = PIU x Originating Rate x Quantity x POU

Terminating Calculation = PIU x Terminating Rate x Quantity x (100-POU)

(C)
|
(C)

(b) Shared End Office Trunk Port

The Shared End Office Trunk Port rate element provides for the use of the shared end office trunk ports for termination of common transport trunk for tandem routed traffic.

(M)

Material previously appeared on this page now appears on 2nd Revised Page 6-171

(This page filed under Transmittal No. 488)

ACCESS SERVICE

6. Switched Access Service (Cont'd)

6.7 Rate Regulations (Cont'd)

6.7.1 Description and Application of Rates and Charges (Cont'd)

(D) Application of Rates (Cont'd)

(5) Local Switching (Cont'd)

(M)

(b) Shared End Office Trunk Port (Cont'd)

A per minute of use charge applies to the shared end office trunk ports for termination of common transport trunks for tandem routed traffic. The chargeable minutes are determined as set forth in 6.7.8, following. The rate is set forth in 6.8.3(C), following.

(M)

(6) Information Surcharge

Information Surcharge rate is applied on a per minute of use basis. Premium rates apply. The Information Surcharge minutes are as set forth in (E) following. The chargeable minutes are determined as set forth in 6.7.8 following. The rates are as set forth in 6.8.8 following.

Material appearing on this page previously appeared on 2nd Revised Page 6-170.

(This page filed under Transmittal No. 488)

ACCESS SERVICE

6. Switched Access Service (Cont'd)

6.7 Rate Regulations (Cont'd)

6.7.1 Description and Application of Rates and Charges (Cont'd)

(D) Application of Rates (Cont'd)

(D)

(D)

(This page filed under Transmittal No. 371)

Issued: September 6, 2007

Effective: September 22, 2007

Four AT&T Plaza, Dallas, Texas 75202

ACCESS SERVICE

6. Switched Access Service (Cont'd)

6.7 Rate Regulations (Cont'd)

6.7.1 Description and Application of Rates and Charges (Cont'd)

(D) Application of Rates (Cont'd)

(9) Transport Application

An Entrance Facility, EISCC, or Direct Trunked Transport is required for all Switched Access Service except when the customer directs its Switched Access Service over another customer's facility as set forth in 6.1.3(A) preceding.

The customer must order Direct Trunked transport from the customer's serving wire center to an end office or to an access tandem with Tandem Switched Transport from the access tandem to the end office(s). Transport options may be selected on a tandem, if tandem routed, and feature group basis.

(C)

(C)

(This page filed under Transmittal No. 371)

ACCESS SERVICE

6. Switched Access Service (Cont'd)6.7 Rate Regulations (Cont'd)6.7.1 Description and Application of Rates and Charges (Cont'd)(D) Application of Rates (Cont'd)(9) Transport Application (Cont'd)

For ALA and FGA Switched Access Service, the customer shall select the first point of switching and Direct Trunked Transport from the Entrance Facility will be provided to the selected first point of switching. In the terminating direction of ALA and FGA, calls, which terminate to end offices other than the first point of switching will be provided over Tandem Switched Transport from the first point of switching to the terminating end office. Tandem Switched Transport rates per minute of use fixed and per minute of use per mile will apply. The chargeable minutes of use for determining the charges are the minutes that are carried over the involved Tandem Switched Transport facilities. The chargeable minutes are determined as set forth in 6.7.8 following. The mileage between the end office involved and the FGA first point of switching is determined as set forth in 6.7.13 following. Tandem Switching charges as set forth in 6.8.2(C)(2) following do not apply.

(C)

(T)

(This page filed under Transmittal No. 371)

Issued: September 6, 2007

Effective: September 22, 2007

Four AT&T Plaza, Dallas, Texas 75202

ACCESS SERVICE

6. Switched Access Service (Cont'd)

6.7 Rate Regulations (Cont'd)

6.7.1 Description and Application of Rates and Charges (Cont'd)

(D) Application of Rates (Cont'd)

(D)

(D)

(This page filed under Transmittal No. 371)

Issued: September 6, 2007

Effective: September 22, 2007

Four AT&T Plaza, Dallas, Texas 75202

ACCESS SERVICE

6. Switched Access Service (Cont'd)

6.7 Rate Regulations (Cont'd)

6.7.1 Description and Application of Rates and Charges (Cont'd)

(D) Application of Rates (Cont'd)

(D)

(D)

(This page filed under Transmittal No. 371)

Issued: September 6, 2007

Effective: September 22, 2007

Four AT&T Plaza, Dallas, Texas 75202

ACCESS SERVICE

6. Switched Access Service (Cont'd)

6.7 Rate Regulations (Cont'd)

6.7.1 Description and Application of Rates and Charges (Cont'd)

(D) Application of Rates (Cont'd)

(D)

(D)

(This page filed under Transmittal No. 371)

Issued: September 6, 2007

Effective: September 22, 2007

Four AT&T Plaza, Dallas, Texas 75202

ACCESS SERVICE

6. Switched Access Service (Cont'd)

6.7 Rate Regulations (Cont'd)

6.7.1 Description and Application of Rates and Charges (Cont'd)

(D) Application of Rates (Cont'd)

(D)

(D)

(This page filed under Transmittal No. 371)

Issued: September 6, 2007

Effective: September 22, 2007

Four AT&T Plaza, Dallas, Texas 75202

ACCESS SERVICE

6. Switched Access Service (Cont'd)

6.7 Rate Regulations (Cont'd)

6.7.1 Description and Application of Rates and Charges (Cont'd)

(D) Application of Rates (Cont'd)

(D)
|
(D)

(E) Toll Free Access Service Charges

The Toll Free Access Service Basic Query charge is assessed to the customer on a per query basis. Additional charges may apply to Toll Free Access Service optional features. These charges are billed in addition to the Basic Query charge. The Six Digit Master Number List Turnaround charge is billed in lieu of the Toll Free Access Basic Query charge when customer identification is performed for Canadian and Caribbean toll free numbers. There are no optional features associated with this function. These charges are as described in 6.8.12 following.

(F) 500 Access Service Charges

A nonrecurring charge is assessed when the customer activates or deactivates the first NXX per central office per order. Each additional NXX activation or deactivation per central office on the same order will have a nonrecurring charge.

(G) Outbound Messaging Application Charges

(1) Outbound Messaging Application Point Code

A Monthly Recurring Charge will be billed for each point code used in conjunction with the Outbound Messaging Application. In configurations where the same point code is used to serve locations in more than one LATA, an additional Monthly Recurring Charge will be incurred for each LATA in which the same point code is used.

(This page filed under Transmittal No. 371)

ACCESS SERVICE

6. Switched Access Service (Cont'd)

(N)

6.7 Rate Regulations (Cont'd)

6.7.1 Description and Application of Rates and Charges (Cont'd)

(G) Outbound Messaging Application Charges (Cont'd)

(2) Outbound Messaging Application per LATA

A Monthly Recurring Charge will be billed for each LATA in which the Outbound Messaging Application is provided.

(3) Outbound Messaging Application Provisioning

A Non-Recurring Charge will be billed for the provisioning of the Outbound Messaging Application Service in each LATA in which the service is provided.

(N)

(This page filed under Transmittal No. 285)

Issued: April 26, 2006

Effective: April 27, 2006

Four AT&T Plaza, Dallas, Texas 75202

ACCESS SERVICE

6. Switched Access Service (Cont'd)

6.7 Rate Regulations (Cont'd)

6.7.4 Minimum Period Charge

The Minimum Period Charge applies when the customer requests disconnect of Switched Access Service prior to the expiration of the thirty day minimum period.

The Minimum Period Charge consists of the following:

(A) Switched Transport Entrance Facility charges; Direct Trunked Transport charges; Dedicated End Office Trunk Port charges, if the service was direct routed; Dedicated Tandem Trunk Port charges, if the service was tandem routed; Switched Transport Multiplexer charges, if provisioned with a multiplexer associated with Entrance Facility and Direct Trunked Transport; and Optional Features per month charges, as set forth in 6.8.7, following. For these Minimum Period Charges, the monthly recurring charge is applied per each rate element and quantity.

(C)
|
(C)

(B) For all usage sensitive rate elements, following but not limited to, the charges are based on actual usage: Tandem Transport Transmission, Tandem Switching, Tandem End office Multiplexing, Information Surcharge, Local Switching, Shared End Office Trunk Port, Basic Toll Free Access Service Query charge and Line Information Data Base (LIDB) Service, as set forth in 6.8 following.

(T)
(T)
(T)
(T)
(T)

(C) Nonrecurring charges associated with the establishment of the service, as set forth in 6.8 following apply.

(T)
(T)

(This page filed under Transmittal No. 371)

ACCESS SERVICE

6. Switched Access Service (Cont'd)

6.7 Rate Regulations (Cont'd)

6.7.6 Change of Feature Group or Access Arrangement Type

Changes from one type of feature group or Access Arrangement to another will be treated as discontinuance of one type of service and a start of another. Nonrecurring charges will apply, with four exceptions.

(1) When a customer upgrades an ALA, FGA, ATA-950 or FGB service to an ATA-101XXXX or FGD service, or an ALA or FGA service to a FGB or ATA-950 service, the nonrecurring charge will not apply if the following conditions are met:

(a) The same customer premises is maintained, and

(b) The disconnection's of ALA or FGA service and the start of FGB, ATA-950, ATA-101XXXX or FGD service are within the same LATA; or the disconnection's of ATA-950 or FGB service and the start of FGD or ATA-101XXXX service are within the same tandem subtending area.

(c)

(D)

(D)

(This page filed under Transmittal No. 371)

ACCESS SERVICE

6. Switched Access Service (Cont'd)

6.7 Rate Regulations (Cont'd)

6.7.6 Change of Feature Group or Access Arrangement Type (Cont'd)

(1) (Cont'd)

- (d) The customer requests the same effective date for both the disconnect of service and start of service, or
- (e) The customer requests that the disconnect date on the ALA, FGA, ATA-950 or FGB service, for the start of ATA-101XXXX or FGD service, be no more than 60 days after allocation. The customer requests the disconnect date of the ALA or FGA service for the start of ATA-950 or FGB service be no more than 90 days after the start of the new ATA-950 or FGB service.
- (f) In the case of an ALA or FGA to ATA-950 or FGB change, the ATA-950 or FGB trunks that are requested are served from an access tandem.

(2)

When the effective dates for the disconnect and start of ATA-101XXXX or FGD service are the same, minimum period obligations will not change, (i.e., the time elapsed in the existing minimum period obligations will be credited to the minimum period obligations for ATA-101XXXX, FGD or the new ATA-950 or FGB). When the effective dates for the disconnect and start of service are different, new minimum period obligations will be established for the ATA-101XXXX, FGD or the new ATA-950 or FGB service. For all other changes from one type of Feature Group or Access Arrangement to another, new minimum period obligations will also be established.

(D)
|
(D)

(This page filed under Transmittal No. 371)

ACCESS SERVICE

6. Switched Access Service (Cont'd)

6.7 Rate Regulations (Cont'd)

6.7.6 Change of Feature Group or Access Arrangement Type (Cont'd)

- (3) When a change of signaling type from multi frequency address signaling to SS7 signaling requires a change of feature group type, i.e., when the FGD or ATA-101XXXX CCSAC optional feature is specified, the nonrecurring charge will not apply, provided there is no change in the physical serving arrangement of existing Switched Access trunks.
- (4) Conversions from an access arrangement to its equivalent feature group will be treated as a discontinuance of one type of service and a start of another (nonrecurring charges will apply, also, new minimum period obligations will be established).

(D)

(D)

(This page filed under Transmittal No. 371)

Issued: September 6, 2007

Effective: September 22, 2007

Four AT&T Plaza, Dallas, Texas 75202

ACCESS SERVICE

6. Switched Access Service (Cont'd)6.7 Rate Regulations (Cont'd)6.7.8 Measuring Access Minutes

Customer traffic to end offices will be measured (i.e., recorded or assumed) by the Telephone Company at end office switches or access tandem switches. Originating and terminating calls will be measured (i.e., recorded or assumed) by the Telephone Company to determine the basis for computing chargeable access minutes.

For Local Switching, Information Surcharge, and Local Switching Optional Features for terminating calls where the off-hook supervisory signal is provided by the customer's equipment over ATA-950, FGB, 8yy, ATA-101XXXX and FGD, and for originating calls over ALA/FGA, the measured minutes are the chargeable access minutes. For terminating calls over ATA-950, FGB, 8yy, ATA-101XXXX, and FGD for Tandem Transport rate elements and Shared End Office Trunk Port, the measured minutes carried over Tandem Switched Transport are the chargeable access minutes.

For Local Switching, Information Surcharge, and Local Switching Optional Features for originating calls with conventional signaling where the off-hook supervisory signal is forwarded by the customer's equipment when the called party answers over ALA/FGA, FGB, ATA-950, ATA-101XXXX, and FGD, the chargeable access minutes are derived from recorded minutes. For originating calls over ATA-950, FGB, ATA-101XXXX and FGD with conventional signaling where the off-hook supervisory signal is forwarded by the customer's equipment when the called party answers for Tandem Switched Transport rate elements and Shared End Office Trunk Port, the chargeable access minutes are derived from recorded minutes carried over Tandem Switched Transport.

(C)

(C)

(This page filed under Transmittal No. 371)

Issued: September 6, 2007

Effective: September 22, 2007

Four AT&T Plaza, Dallas, Texas 75202

ACCESS SERVICE

6. Switched Access Service (Cont'd)

6.7 Rate Regulations (Cont'd)

6.7.8 Measuring Access Minutes (Cont'd)

Step 1: Obtain recorded originating minutes and messages (measured as set forth in (B) and (C) following for ALA, FGA, ATA-101XXXX and FGD respectively) from the appropriate recording data.

(D)

Step 2: Where measurement is not available, obtain the total attempts by dividing the originating measured messages by the completion ratio. Completion ratios (CR) are obtained for the major call categories such as DDD, operator, 8yy, 900, directory assistance and international from a sample study which analyzes the ultimate completion status of the total attempts which receive acknowledgement from the customer. That is, Measured Messages divided by Completion Ratio equals Total Attempts.

(T)

(This page filed under Transmittal No. 371)

Issued: September 6, 2007

Effective: September 22, 2007

Four AT&T Plaza, Dallas, Texas 75202

ACCESS SERVICE

6. Switched Access Service (Cont'd)6.7 Rate Regulations (Cont'd)6.7.8 Measuring Access Minutes (Cont'd)

Step 3: Obtain the total non-conversation time additive (NCTA) by multiplying the total attempts (obtained in Step 2) by the NCTA per attempt ratio. The NCTA per attempt ratio is obtained from the sample study identified in Step 2 by measuring the non-conversation time associated with both completed and incompletd attempts. The total NCTA is the time on a completed attempt from customer acknowledgement of receipt of call to called party answer (set up and ringing) plus the time on an incompletd attempt from customer acknowledgement of call until the access tandem or end office receives a disconnect signal (ring - no answer, busy or network blockage). That is, Total Attempts times Non-Conversation Time per Attempt Ratio equals Total NCTA.

Step 4: Obtain total chargeable originating access minutes by adding the total NCTA (obtained in Step 3) to the recorded originating measured minutes (obtained in Step 1). That is, Measured Minutes plus NCTA equals Chargeable Originating Access Minutes.

Following is an example which illustrates how the chargeable originating access minutes are derived from the measured originating minutes using this formula.

Where: Measured Minutes (M. Min.) = 7,000
 Measured Messages (M. Mes.) = 1,000
 Completion Ratio (CR) = .75
 NCTA per Attempt = .4

$$(1) \text{ Total Attempts} = \frac{1,000 \text{ (M. Mes)}}{.75 \text{ (CR)}} = 1,333.00$$

$$(2) \text{ Total NCTA} = .4 \text{ (NCTA per Attempt)} \times 1,333.33 = 533.33$$

$$(3) \text{ Total Chargeable Originating Access Minutes} = 7,000 \text{ (M. Min)} + 533.33 \text{ (NCTA)} = 7,533.33$$

When assumed minutes are used, the assumed minutes are the chargeable access minutes.

(This page filed under Transmittal No. 1)

ACCESS SERVICE

6. Switched Access Service (Cont'd)6.7 Rate Regulations (Cont'd)6.7.8 Measuring Access Minutes (Cont'd)

ALA and FGA access minutes or fractions thereof, the exact value of the fraction being a function of the switch technology where the measurement is made, are accumulated over the billing period for each line or hunt group, and are then rounded up to the nearest access minute for each line or hunt group. FGB, ATA-950, ATA-101XXXX and FGD (except FGD and ATA-101XXXX used for PSDS Access) access minutes or fractions thereof, the exact value of the fraction being a function of the switch technology where the measurement is made, are accumulated over the billing period for each end office, and are then rounded up to the nearest access minute for each end office. For ATA-101XXXX and FGD used for PSDS Access, access minutes are not accumulated over the billing period and then rounded up, but are rounded up on a per call basis. For PSDS Access, the charge of one access minute applies for one minute or any fraction thereof, (e.g., for a PSDS Access call of 3/4 of one minute, the charge of one access minute applies; for a PSDS Access Call of 1 3/4 minutes, the charge of two access minutes applies).

(D)

Assumed minutes are used for ALA and FGA service which originate or terminate in end offices not equipped with measurement capabilities.

The assumed average interstate access minutes for ALA and FGA are as set forth following.

When an ALA or FGA service arranged for two way calling is provided where neither the originating nor terminating access minutes are recorded, the assumed average interstate access minutes per two-way service are 2980 access minutes. 1192 access minutes are assumed to be originating and 1788 access minutes are assumed to be terminating. When an ALA or FGA service arranged for two-way calling is provided where recording capability exists for either originating or terminating usage, but not both, the number of assumed access minutes per two-way service will be 2980 access minutes or the recorded usage, whichever is greater. If the usage in the measured direction exceeds 2980 access minutes, it will be assumed that there is zero usage in the unmeasured direction. If the measured usage is less than 2980 access minutes, the usage in the unmeasured direction will be assumed to be 2980 access minutes minus the measured usage (e.g., 2980 - 1000 measured = 1980 assumed in the unmeasured direction).

(This page filed under Transmittal No. 371)

6. Switched Access Service (Cont'd)6.7 Rate Regulations (Cont'd)6.7.8 Measuring Access Minutes (Cont'd)

Additionally, when any or all the usage over an unmeasured ALA or FGA line originates from or terminates to a WATS Access Line(s) and the total ALA or FGA usage recorded at the WATS Serving Office(s) exceeds the assumed usage set forth preceding for ALA or FGA, the recorded usage will be billed to the customer in lieu of the assumed usage.

When an ALA or FGA service arranged for originating calling only is provided where originating access minutes are not recorded, the assumed average originating access minutes are 1192 access minutes and no terminating access minutes will apply.

When a ALA or FGA service arranged for terminating calling only is provided where terminating access minutes are not recorded, the assumed average terminating access minutes are 1788 access minutes and no originating access minutes will apply.

(A) ALA and Feature Group A Usage Measurement

For originating calls over and ALA or FGA, usage measurement begins when the originating ALA or FGA entry switch receives an off-hook supervisory signal forwarded from the customer's point of termination. This off-hook signal is either provided by the customer's equipment, or is forwarded by the customer's equipment when the called party answers.

The measurement of originating call usage over ALA or FGA ends when the originating ALA or FGA entry switch receives an on-hook supervisory signal from either the originating end user's end office, indicating the originating end user has disconnected, or the customer's point of termination, whichever is recognized first by the entry switch.

For terminating calls over ALA or FGA, usage measurement begins when the terminating ALA or FGA entry switch receives an off-hook supervisory signal from the terminating end user's end office, indicating the terminating end user has answered. The measurement of terminating call usage over ALA or FGA ends when the terminating ALA or FGA entry switch receives an on-hook supervisory signal from either the terminating end user's end office, indicating the terminating end user has disconnected, or the customer's point of termination, whichever is recognized first by the entry switch.

(This page filed under Transmittal No. 1)

ACCESS SERVICE

6. Switched Access Service (Cont'd)

6.7 Rate Regulations (Cont'd)

6.7.8 Measuring Access Minutes (Cont'd)

(B) Feature Group B and ATA-950 Usage Measurement

For originating calls over ATA-950 or FGB, usage measurement begins when the originating ATA-950 or FGB entry switch receives answer supervision forwarded from the customer's point of termination, indicating the customer's equipment has answered.

The measurement of originating call usage over ATA-950 or FGB ends when the originating ATA-950 or FGB entry switch receives disconnect supervision from either the originating end user's end office, indicating the originating end user has disconnected, or the customer's point of termination, whichever is recognized first by the entry switch.

For terminating calls over ATA-950 or FGB, usage measurement begins when the terminating ATA-950 or FGB entry switch receives answer supervision from the terminating end user's end office, indicating the terminating end user has answered.

The measurement of terminating call usage over ATA-950 or FGB ends when the terminating ATA-950 or FGB entry switch receives disconnect supervision from either the terminating end user's end office, indicating the terminating end user has disconnected, or the customer's point of termination, whichever is recognized first by the entry switch.

(C)

(D)

(D)

(This page filed under Transmittal No. 371)

ACCESS SERVICE

6. Switched Access Service (Cont'd)

6.7 Rate Regulations (Cont'd)

6.7.8 Measuring Access Minutes (Cont'd)

(C)

(D)

(D)

(This page filed under Transmittal No. 371)

Issued: September 6, 2007

Effective: September 22, 2007

Four AT&T Plaza, Dallas, Texas 75202

ACCESS SERVICE

6. Switched Access Service (Cont'd)6.7 Rate Regulations (Cont'd)6.7.8 Measuring Access Minutes (Cont'd)(D) ATA-101XXXX and Feature Group D Usage Measurement

For originating calls over ATA-101XXXX or FGD with multifrequency address signaling, usage measurement begins when the originating ATA-101XXXX or FGD entry switch receives the first wink supervisory signal forwarded from the customer's point of termination. For originating calls over ATA-101XXXX or FGD with SS7 signaling, usage measurement begins when the last point of switching sends the initial address message to the customer.

The measurement of originating call usage over ATA-101XXXX or FGD ends when the originating ATA-101XXXX or FGD entry switch receives disconnect supervision from either the originating end user's end office, indicating the originating end user has disconnected, or the customer's point of termination, whichever is recognized first by the entry switch.

For terminating calls over ATA-101XXXX or FGD, the measurement of access minutes begins when the terminating ATA-101XXXX or FGD entry switch receives answer supervision from the terminating end user's end office, indicating the terminating end user has answered.

The measurement of terminating call usage over ATA-101XXXX or FGD ends when the terminating ATA-101XXXX or FGD entry switch receives disconnect supervision from either the terminating end user's end office, indicating the terminating end user has disconnected, or the customer's point of termination, whichever is recognized first by the entry switch.

(This page filed under Transmittal No. 371)

ACCESS SERVICE

6. Switched Access Service (Cont'd)

6.7 Rate Regulations (Cont'd)

6.7.8 Measuring Access Minutes (Cont'd)

(D)

(D)

(This page filed under Transmittal No. 550)

Issued: January 24, 2017

Effective: February 8, 2017

675 W. Peachtree St. NW, Atlanta, GA 30308

ACCESS SERVICE

6. Switched Access Service (Cont'd)6.7 Rate Regulations (Cont'd)

6.7.9

6.7.10 Application of Rates ALA and for Feature Group A Extension Service

ALA and FGA Switched Access Service is available with extensions, i.e., additional terminations of the service at different building(s) in the same ^(T) or a different LATA. ALA and Feature Group A extensions in the same LATA and same state are charged for under the Telephone Company's local and/or general exchange service tariffs. ALA and FGA extensions in different LATAs or in a different state in the same LATA are charged for as Special Access Service. The rate elements which apply are: A Voice Grade Channel Termination, Channel Mileage, if applicable, and signaling capability, if applicable. All appropriate monthly rates and nonrecurring charges set forth in 7.5.3 (Voice Grade Service) following will apply. Such extensions are ordered as set forth in 5.2 (Access Order) preceding.

(This page filed under Transmittal No. 1)

Issued: April 27, 2000

Effective: May 12, 2000

Four AT&T Plaza, Dallas, Texas 75202

ACCESS SERVICE

6. Switched Access Service (Cont'd)6.7 Rate Regulations (Cont'd)6.7.11 Message Unit Credit

Calls from End Users to the seven-digit local telephone numbers associated with ALA and Feature Group A Switched Access Service are subject to Telephone Company local and or general exchange service tariff charges (including message unit and toll charges as applicable). The monthly bills rendered to customers for their ALA and Feature Group A Switched Access Service will include a credit to reflect any message unit charges collected from their End Users under the Telephone Company's local and or general exchange service tariffs. The credit will apply for recorded originating usage or for assumed originating usage, as appropriate for the ALA and FGA service provided. When the credit is applied on assumed usage, such credit will not exceed the assumed levels of usage set forth in 6.7.8 preceding. No credit will apply for any terminating ALA and FGA access minutes. The message unit credit for originating ALA and FGA access minutes is as set forth in 6.8.6 following.

6.7.12 Community Information Services

Calls over Switched Access in the terminating direction to certain community information services will be rated under the applicable rates for Switched Access Service as set forth in 6.8 following. In addition, the charges per call as specified under the Telephone Company's local and/or general exchange service tariffs, e.g., 976 (DIAL-IT) Network Services, will also apply.

(This page filed under Transmittal No. 1)

ACCESS SERVICE

6. Switched Access Service (Cont'd)

6.7 Rate Regulations (Cont'd)

6.7.13 Mileage Measurement

The mileage to be used to determine the usage distance sensitive portion of the Switched Transport rate is calculated on the airline distance between the end office switch where the call carried by Switched Transport originates or terminates and the access tandem. Mileage to be used to determine the monthly rate for Direct Trunked Transport is calculated on the airline distance between the access tandem and the customer's serving wire center for Tandem Switched Transport and the airline distance between the end office and the customer's serving wire center for traffic not routed through an access tandem, except as set forth in (A) through (F) following. The V&H Coordinates method is used to determine mileage. This method is set forth in the NECA Tariff F.C.C. No. 4.

(T)

(N)

(N)

(Z)

(Z)

Host-Remote

When Direct Trunked Transport is provided to a host-remote arrangement, mileage for Direct Trunked Transport is calculated using the V&H coordinates of the customer's serving wire center and the host office. Mileage for Host Remote Transmission is calculated using the V&H coordinates of the host office and the remote switching system or remote switching module where the call originates or terminates.

When Tandem Switched Transport is provided to a host-remote arrangement, mileage for Tandem Switched Transmission is calculated using the V&H coordinates of the tandem and the host office. Mileage for Host Remote Transmission is calculated using the V&H coordinates of the host office and the remote switching system or remote switching module where the call originates or terminates.

To determine the rate to be billed, compute the mileage using the V&H coordinates method, and apply to the rate shown in 6.8. following. If the calculation results in a fraction of a mile, always round up to the next whole mile before determining the mileage and applying the rates.

Hubbing

When hubbing is requested at a location other than the serving wire center, the V&H Coordinates method is used to separately calculate mileage for Direct Trunked Transport from the serving wire center to hub, from hub to hub (if more than one hub is provided), and from hub to access tandem (for tandem routed) or from hub to end office (for direct routed).

(N)

(N)

(This page filed under Transmittal No. 371)

ACCESS SERVICE

6. Switched Access Service (Cont'd)

6.7 Rate Regulations (Cont'd)

6.7.13 Mileage Measurement (Cont'd)

Exceptions to the mileage measurement rules are as follows:

- (A) Mileage for Direct Trunked Transport for ALA or FGA Switched Access Service will be calculated on an airline basis, using the V&H coordinates method, between the end office switch where the ALA or Feature Group A switching dial tone is provided and the customer's serving wire center for the Switched Access Service provided.

In addition, mileage in the terminating direction for ALA or FGA Switched Access Service access minutes which terminate at an end office other than the end office switch where the ALA or FGA switching dial tone is provided, will be calculated on an airline basis, using the V&H coordinates method, between the end office switch where the access minutes terminate and the end office switch where the ALA or FGA switching dial tone is provided. Tandem Switched Transmission per minute of use fixed and per minute of use per mile charges, Tandem End Office Multiplexing and Shared End Office Trunk Port per minute of use charges will be billed for these access minutes (excluding Tandem Switching).

(T)
(N)
(N)
(N)

(This page filed under Transmittal No. 371)

ACCESS SERVICE

6. Switched Access Service (Cont'd)6.7 Rate Regulations (Cont'd)6.7.13 Mileage Measurement (Cont'd)

- (B) When the Alternate Traffic Routing optional feature is provided with FGB, FGD, ATA-950 and ATA-101XXXX to provide service from an end office to different customer premises locations, usage rated Tandem Switched Transport access minutes will be apportioned between the two transmission routes used to provide this feature. For ATA-950 and FGB, such apportionment will be made using standard Telephone Company traffic engineering methodology and will be based on the last trunk CCS desired for the high usage group, as described in 6.3.1(O), preceding, and the relative capacity ordered to the end office, when the feature is provided at an end office switch, or to the subtending end offices when the feature is provided at an access tandem switch. For ATA-101XXXX and FGD, the Tandem Switched transport mileage calculation will be based on the actual measured data which is recorded against the specific trunk group that carried a particular call. The customer will be billed accordingly.
- (D)
- (D)
- (Z)

(This page filed under Transmittal No. 371)

ACCESS SERVICE

6. Switched Access Service (Cont'd)

6.7 Rate Regulations (Cont'd)

6.7.13 Mileage Measurement (Cont'd)

(C) Switched Transport mileage for access minutes originating from or terminating at a remote switching system or module (RSS or RSM) will be calculated on an airline basis between the customer premises serving wire center and the end office switch that serves as the host office and from the host office to the remote office serving the customer.

Host Remote Transmission mileage always applies between the host end office and the remote switching system or module. Direct Trunked Transport mileage is between the customer's premises serving wire center and the host end office, if directly routed, or, if tandem routed, the mileage is between the customer's premises serving wire center and the access tandem. With tandem routing, Tandem Transport Transmission mileage is between the access tandem and the host end office.

(N) |

(D) When terminating ATA-950 or FGB is provided from multiple customer's premises to an end office not equipped with measurement capabilities, the total Tandem Switched Transport access minutes for the end office will be apportioned among the trunk groups accessing the end office on the basis of the individual capacity, i.e., trunks ordered for each of those trunk groups. This apportionment will serve as the basis for Tandem Switched Transport mileage calculations.

(N)
(D)

(E) Where measurement capability does not exist and/or end office specific usage data is not available, ALA and FGA terminating usage will be apportioned among the end offices in the access area of the entry switch to which the service is provided, as described following. The usage to be apportioned will be the recorded usage or the assumed usage as set forth in 6.7.8 preceding.

Such apportionment will be based on the ratio of the number of subscriber lines served by each end office in the access area to the total number of subscriber lines in the access area. The ratio thus developed is applied to the total ALA and FGA terminating usage.

Tandem Switched Transport mileage for the access minutes apportioned in this manner will be calculated on an airline basis, using the V&H coordinates method, between each end office to which minutes have been apportioned and the end office switch where the ALA or FGA switching dial tone is provided.

(This page filed under Transmittal No. 371)

ACCESS SERVICE

6. Switched Access Service (Cont'd)

6.7 Rate Regulations (Cont'd)

6.7.13 Mileage Measurement (Cont'd)

(F) The Switched Transport mileage for access minutes which originate from or terminate to a WATS Access Line, except as set forth following, will be calculated on an airline basis, using the V&H coordinates method, between the WATS serving office at which the WATS Access Line terminates and the customer premises serving wire center for the Switched Access Service provided.

When ALA and FGA usage originating from or terminating to a WATS Access Line Service is transported over an ALA and FGA line for which assumed minutes of use are billed, the Switched Transport Mileage for such usage will be calculated in accordance with (A) or (E) preceding as appropriate.

(G) The Switched Transport mileage for access minutes which originate from or terminate to a Mobile End Office Connection or a Mobile Access Tandem Connection, will be calculated on an airline basis, using the V&H coordinates method, between the customer's serving wire center and the end office or access tandem switch where the Mobile Carrier's Mobile End Office Connection or Mobile Access Tandem Connection is located.

6.7.14

(D)

(D)

(This page filed under Transmittal No. 371)

ACCESS SERVICE

6. Switched Access Service (Cont'd)

6.7 Rate Regulations (Cont'd)

6.7.15 Shared Use

Shared use occurs when Switched Access Service and Special Access Service are provided over the same analog, digital high capacity, or SONET based service (except OC3c and OC12c circuit service) through a common interface. The regulations governing the provision of Shared Use Facilities are set forth in 5.2.10 preceding. Switched Access rates and charges as set forth in 6.8 following will apply for each channel of the high capacity facility that is used to provide Switched Access Service.

(C)
(C)
(C)

Below is a chart showing the SONET based service's switched transport billing equivalent. The chart is used to find which switched transport rate element to bill when switched traffic is sharing a common interface with SONET service.

(N)

SONET Based Service	Switched Transport
DS1 Circuit Service	DS1
DS3 Circuit Service	DS3
STS1 Circuit Service	DS3
OC3 Circuit Service	DS3x3
STS12 Circuit Service	DS3x12
OC3 Ring	DS3x3
OC12 Ring	DS3x12
OC48 Ring	DS3x12 multiplied by 4

(N)

6.7.17 Information Surcharge

The Information Surcharge is a charge to recover costs that have been assigned to the interstate Information category through Parts 36 and 69 of the Commission's Rules. These costs are other than those incurred in the provision of interstate Directory Assistance Service as set forth in 9. following.

The Information Surcharge is assessed to the customer based on the total number of access minutes. The rates are set forth in 6.8.8 following. The application of these rates with respect to the individual Switched Access Services is as set forth in 6.7.1(E) preceding.

(This page filed under Transmittal No. 24)

ACCESS SERVICE

6. Switched Access Service (Cont'd)6.7 Rate Regulations (Cont'd)6.7.18 Billing Name and Address Service

- (A) The Telephone Company will, upon request, provide Billing Name and Address (BNA) Service for billing purposes only. BNA information will be released for subscribers when the customer or their authorized billing agent needs the information to bill a call and the originating telephone number is provided.

The Telephone Company will not release BNA information in the event a subscriber request that such information not be disclosed.

- (B) Magnetic Tape will be established as the standard format for the receipt of telephone numbers and the provision of billing name and address information. If in the course of Telephone Company business it is necessary to change the format, the Telephone Company will provide notification to the involved customer's one month prior to the change. The Telephone Company will specify the locations(s) where requests are to be received.
- (C) The customer shall order BNA under a Special Order 30 days prior to delivery of the first customer provided magnetic tape to the Telephone Company. The customer shall also provide a test magnetic tape to the Telephone Company 30 days in advance of the proposed delivery of the customer provided magnetic tape. With each order, the customer shall identify the authorized individual and address to receive the BNA output.

(This page filed under Transmittal No. 1)

ACCESS SERVICE

6. Switched Access Service (Cont'd)6.7 Rate Regulations (Cont'd)6.7.18 Billing Name and Address Service (Cont'd)

- (D) The Telephone Company will receive from the customer a magnetic tape which contains the originating telephone numbers obtained through Automatic Number Identification. The frequency for receipt of the customer provided magnetic tapes will be at intervals, mutually agreed upon between the Telephone Company and the customer. The telephone numbers will programmatically be associated with the proper subscriber billing name and address contained in the CRIS file at that time. The information will be returned to the customer according to the established procedures.
- (E) BNA Service detail will not be retained by the Utility for longer than 45 days. If the customer requests that the initially provided output magnetic tape be made available again, such requests must be within 30 days from the date the first output magnetic tape was made available.
- (F) Under no circumstances shall the customer or their authorized billing agent resell the information, use the information in connection with marketing, or provide the tapes or information to any parent, subsidiary, affiliate, agent of the customer, or to any third party.
- (G) The charges for Billing Name and Address Service are set forth in 6.8.13 following.

(This page filed under Transmittal No. 1)

ACCESS SERVICE

6. Switched Access Service (Cont'd)

6.8 Rates and Charges

6.8.1 X.25 Charges⁽¹⁾

(A) Dedicated Connections

(1) X.75 Internetwork Interface

Synchronous	<u>Monthly Rate</u>	<u>Nonrecurring Charge</u>	<u>USOC</u>
- 9.6 Kbps	\$450.00	\$400.00	LADS9
- 56 Kbps	600.00	450.00	LADS5

(B) Usage Rate Charges

-

	<u>Peak</u>	<u>Off-Peak</u>
- Per Call Set-up	\$0.00500	\$0.00500
- Per segment of each call	0.00050	0.00050

(C) Per Minute Charges*

- initial minute	0.020	0.020
- each additional minute	0.010	0.010

(D) Optional Features

	<u>Monthly Rate</u>	<u>Nonrecurring Charge</u>	<u>USOC</u>
(1) Permanent Virtual Circuit (each circuit end)	\$12.50	\$25.00	LADPV

* Charges associated with public dial connection access to the X.25 network. These charges are billed to the X.75 customer.

(1)As of October 6, 2004, X.25 and X.75 protocols are obsolete and limited to existing installations, at existing locations, for existing customers.

(T)

(This page filed under Transmittal No. 371)

Issued: September 6, 2007

Effective: September 22, 2007

Four AT&T Plaza, Dallas, Texas 75202

ACCESS SERVICE

6. Switched Access Service (Cont'd)

6.8 Rates and Charges (Cont'd)

6.8.1 X.25 Charges (Cont'd)⁽¹⁾

(D) Optional Features (Cont'd)

(C)

	<u>Monthly Rate</u>	<u>Nonrecurring Charge</u>	<u>USOC</u>
(2) Fast Select			
(a) Initiate (each DNA)	\$5.00	\$10.00	LADFS
(b) Acceptance (each DNA)	5.00	10.00	LADFA
(3) Hunt Group - Internal (each DNA)	2.50	10.00	LADHG
(4) Closed User Group (each DNA)	20.00	0.00	LADCU
(a) Incoming and outgoing calls limited to a Customer's CUG	2.50	0.00	LADC2
(b) Incoming calls allowed from the open network	2.50	0.00	LADCN
(c) Outgoing calls allowed to the open network	2.50	0.00	LADCT

(N)
(N)

(1)As of October 6, 2004, X.25 and X.75 protocols are obsolete and limited to existing installations, at existing locations, for existing customers.

(This page filed under Transmittal No. 170)

ACCESS SERVICE

6. Switched Access Service (Cont'd)

6.8 Rates and Charges (Cont'd)

6.8.1 X.25 Charges (Cont'd)⁽¹⁾

(D) Optional Features (Cont'd)

(C)

	<u>Monthly Rate</u>	<u>Nonrecurring Charge</u>	<u>USOC</u>
(d) Incoming calls allowed within the CUG	\$2.50	\$0.00	LADCD
(e) Outgoing calls allowed within the CUG	2.50	0.00	LADCE
(5) DTE Back-up (each alternate DNA)	5.00	20.00	LADTB
(6) Additional Logical Channels (each channel)	3.00	10.00	LADLC

(E) Change Charges

(1) Optional features - per billing telephone number		75.00	LADCH
(2) DNA number change - per billing telephone number		75.00	LADCH
(3) Parameter options - per billing telephone number		75.00	LADCH

(N)
(N)

(1)As of October 6, 2004, X.25 and X.75 protocols are obsolete and limited to existing installations, at existing locations, for existing customers.

(This page filed under Transmittal No. 170)

ACCESS SERVICE

6. Switched Access Service (Cont'd)

6.8 Rates and Charges (Cont'd)

6.8.2 Switched Transport

(A) Entrance Facilities (Per Point of Termination)

	USOC	Zone	Monthly Rate	Nonrecurring Charges	
				1st	Add'l
(1) Voice Grade					
2-wire	TSW2X	1	\$ 10.50	\$362.50	\$325.00
2-wire	TSW2X	2	10.50	502.50	325.00
2-wire	TSW2X	3	10.50 (I)	502.50	325.00
4-wire	TSW4X	1	18.56 (R)	502.50	325.00
4-wire	TSW4X	2	18.56 (R)	502.50	325.00
4-wire	TSW4X	3	18.56 (I)	502.50	325.00
(2) DS1					
	TMESW	1	52.00	192.50	77.00
	TMESW	2	72.00	192.50	77.00
	TMESW	3	75.79	250.00	100.00

Rates contained in this transmittal are subject to subsequent adjustment, effective retrospectively, in the event the Commission or a court subsequently authorizes Pacific to correct its rates pursuant to pending motions, or petitions for reconsideration or waiver, or in the event of any other adjustment to an order of the Commission or a court.

(This page filed under Transmittal No. 355)

Issued: June 15, 2007

Effective: June 30, 2007

Four AT&T Plaza, Dallas, Texas 75202

ACCESS SERVICE

6. Switched Access Service (Cont'd)

6.8 Rates and Charges (Cont'd)

6.8.2 Switched Transport (Cont'd)

(A) Entrance Facilities (Per Point of Termination) (Cont'd)

(3) Month-to-Month	<u>USOC</u>	<u>Monthly Nonrecurring Rates</u>	<u>Charges</u>
- Fiber Advantage SM DS3 with Terminal Equipment			
Zone 1	Z3MSW	\$ 900.00 (R)	\$31,000.00
Zone 2	Z3MSW	900.00 (R)	31,000.00
Zone 3	Z3MSW	1,000.00	31,000.00
- Fiber Advantage SM DS3 without Terminal Equipment			
Zone 1	Z0MSW	720.00 (R)	21,150.00
Zone 2	Z0MSW	720.00 (R)	21,150.00
Zone 3	Z0MSW	800.00	21,150.00
- Fiber Advantage SM DS3x3 with Terminal Equipment			
Zone 1	Z3MSW	2,430.00 (R)	56,200.00
Zone 2	Z3MSW	2,430.00 (R)	56,200.00
Zone 3	Z3MSW	2,700.00	56,200.00
- Fiber Advantage SM DS3x3 without Terminal Equipment			
Zone 1	Z0MSW	1,944.00 (R)	43,200.00
Zone 2	Z0MSW	1,944.00 (R)	43,200.00
Zone 3	Z0MSW	2,160.00	43,200.00

Rates contained in this transmittal are subject to subsequent adjustment, effective retrospectively, in the event the Commission or a court subsequently authorizes Pacific to correct its rates pursuant to pending motions, or petitions for reconsideration or waiver, or in the event of any other adjustment to an order of the Commission or a court.

(This page filed under Transmittal No. 117)

Issued: June 16, 2003

Effective: July 1, 2003

Four AT&T Plaza, Dallas, Texas 75202

6. Switched Access Service (Cont'd)

6.8 Rates and Charges (Cont'd)

6.8.2 Switched Transport

(A) Entrance Facilities (Per Point of Termination) (Cont'd)

(4) Fiber AdvantageSM DS3 and DS3x3 Rate Stability
 Payment Plan

	<u>USOC</u>	<u>Monthly Rates</u>	<u>Nonrecurring Charges</u>
(a) 1 Year Plan			
- Fiber Advantage SM DS3 with Terminal Equipment			
Zone 1	Z3MSW/Z31SW	\$740.00 (I)	\$3,000.00
Zone 2	Z3MSW/Z31SW	775.00 (I)	3,250.00
Zone 3	Z3MSW/Z31SW	860.00 (I)	3,500.00
- Fiber Advantage SM DS3 without Terminal Equipment			
Zone 1	Z0MSW/Z01SW	576.00	2,000.00
Zone 2	Z0MSW/Z01SW	576.00	2,025.00
Zone 3	Z0MSW/Z01SW	640.00	2,500.00
- Fiber Advantage SM DS3x3 with Terminal Equipment			
Zone 1	Z3MSW/Z31SW	1,728.00	5,500.00
Zone 2	Z3MSW/Z31SW	1,728.00	6,000.00
Zone 3	Z3MSW/Z31SW	1,920.00	6,500.00
- Fiber Advantage SM DS3x3 without Terminal Equipment			
Zone 1	Z0MSW/Z01SW	1,382.40	4,000.00
Zone 2	Z0MSW/Z01SW	1,382.40	4,500.00
Zone 3	Z0MSW/Z01SW	1,536.00	5,000.00

Rates contained in this transmittal are subject to subsequent adjustment, effective retrospectively, in the event the Commission or a court subsequently authorizes Pacific to correct its rates pursuant to pending motions, or petitions for reconsideration or waiver, or in the event of any other adjustment to an order of the Commission or a court.

(This page filed under Transmittal No. 355)

Issued: June 15, 2007

Effective: June 30, 2007

Four AT&T Plaza, Dallas, Texas 75202

6. Switched Access Service (Cont'd)

6.8 Rates and Charges (Cont'd)

6.8.2 Switched Transport (Cont'd)

(A) Entrance Facilities (Per Point of Termination) (Cont'd)

(4) Fiber AdvantageSM DS3 and DS3x3 Rate Stability
Payment Plan (Cont'd)

	<u>USOC</u>	<u>Monthly Rates</u>	<u>Nonrecurring Charges</u>
(b) <u>3 Year Plan</u>			
- Fiber Advantage SM DS3 with Terminal Equipment			
Zone 1	Z3MSW/Z33SW	690.00 (I)	\$1,500.00
Zone 2	Z3MSW/Z33SW	700.00 (I)	1,625.00
Zone 3 S38	Z3MSW/Z33SW	760.00 (I)	1,750.00
- Fiber Advantage SM DS3 without Terminal Equipment			
Zone 1	Z0MSW/Z03SW	540.00	1,000.00
Zone 2	Z0MSW/Z03SW	540.00	1,125.00
Zone 3	Z0MSW/Z03SW	600.00	1,250.00
- Fiber Advantage SM DS3x3 with Terminal Equipment			
Zone 1	Z3MSW/Z33SW	1,417.50	2,750.00
Zone 2	Z3MSW/Z33SW	1,417.50	3,000.00
Zone 3	Z3MSW/Z33SW	1,575.00	3,250.00
- Fiber Advantage SM DS3x3 without Terminal Equipment			
Zone 1	Z0MSW/Z03SW	1,134.00	2,000.00
Zone 2	Z0MSW/Z03SW	1,134.00	2,025.00
Zone 3	Z0MSW/Z03SW	1,260.00	2,500.00

Rates contained in this transmittal are subject to subsequent adjustment, effective retrospectively, in the event the Commission or a court subsequently authorizes Pacific to correct its rates pursuant to pending motions, or petitions for reconsideration or waiver, or in the event of any other adjustment to an order of the Commission or a court.

(This page filed under Transmittal No. 355)

Issued: June 15, 2007

Effective: June 30, 2007

Four AT&T Plaza, Dallas, Texas 75202

ACCESS SERVICE

6. Switched Access Service (Cont'd)

6.8 Rates and Charges (Cont'd)

6.8.2 Switched Transport

(A) Entrance Facilities (Per Point of Termination) (Cont'd)

(4) Fiber AdvantageSM DS3 and DS3x3 Rate Stability
 Payment Plan (Cont'd)

	<u>USOC</u>	<u>Monthly Rates</u>	<u>Nonrerring Charges</u>
(b) <u>3 Year Plan</u> (Cont'd)			
- Fiber Advantage SM DS3x12 with Terminal Equipment			
Zone 1	Z3MSW/Z23SE	\$4,860.00 (R)	\$3,500.00
Zone 2	Z3MSW/Z23SE	4,860.00 (R)	4,500.00
Zone 3	Z3MSW/Z23SE	5,400.00	6,000.00
- Fiber Advantage SM DS3x12 without Volume 12 Terminal Equipment			
Zone 1	Z0MSW/Z23SO	3,402.00 (R)	3,000.00
Zone 2	Z0MSW/Z23SO	3,888.00 (R)	4,000.00
Zone 3	Z0MSW/Z23SO	3,240.00	5,000.00
- Fiber Advantage OC48 with Equipment			
Zone 1	Z3MSW		
Zone 2	Z3MSW		
Zone 3	Z3MSW		
- Fiber Advantage OC48 without Equipment			
Zone 1	Z0MSW		
Zone 2	Z0MSW		
Zone 3	Z0MSW		

Rates contained in this transmittal are subject to subsequent adjustment, effective retrospectively, in the event the Commission or a court subsequently authorizes Pacific to correct its rates pursuant to pending motions, or petitions for reconsideration or waiver, or in the event of any other adjustment to an order of the Commission or a court.

(This page filed under Transmittal No. 117)

Issued: June 16, 2003

Effective: July 1, 2003

Four AT&T Plaza, Dallas, Texas 75202

ACCESS SERVICE

6. Switched Access Service (Cont'd)

6.8 Rates and Charges (Cont'd)

6.8.2 Switched Transport

(A) Entrance Facilities (Per Point of Termination) (Cont'd)

(4) Fiber AdvantageSM DS3 and DS3x3 Rate Stability

Payment Plan (Cont'd)

	<u>USOC</u>	<u>Monthly Rates</u>	<u>Nonrecurring Charges</u>	(C)
(c) 5 Year Plan ⁽¹⁾				
- Fiber Advantage SM				
DS3 with				
Terminal Equipment				
Zone 1	Z3MSW/Z35SW	\$650.00	0,000.00#	
Zone 2	Z3MSW/Z35SW	675.00	0,000.00#	
Zone 3	Z3MSW/Z35SW	700.00	0,000.00#	
- Fiber Advantage SM				
DS3 without				
Terminal Equipment				
Zone 1	Z0MSW/Z05SW	504.00	0,000.00#	
Zone 2	Z0MSW/Z05SW	504.00	0,000.00#	
Zone 3	Z0MSW/Z05SW	560.00	0,000.00#	
- Fiber Advantage SM				
DS3x3 with				
Terminal Equipment				
Zone 1	Z3MSW/Z35SW	1,134.00	0,000.00#	
Zone 2	Z3MSW/Z35SW	1,134.00	0,000.00#	
Zone 3	Z3MSW/Z35SW	1,260.00	0,000.00#	
- Fiber Advantage SM				
DS3x3 without				
Terminal Equipment				
Zone 1	Z0MSW/Z05SW	907.20	0,000.00#	
Zone 2	Z0MSW/Z05SW	907.20	0,000.00#	
Zone 3	Z0MSW/Z05SW	1,008.00	0,000.00#	

Nonrecurring charges associated with the installation of Fiber AdvantageSM Services under a 5-year⁽¹⁾ Rate Stability Plan are waived. (C)

Rates contained in this transmittal are subject to subsequent adjustment, effective retrospectively, in the event the Commission or a court subsequently authorizes Pacific to correct its rates pursuant to pending motions, or petitions for reconsideration or waiver, or in the event of any other adjustment to an order of the Commission or a court.

(1) Effective on March 1, 2019, Switched Access Term Plans of greater than 36 months are no longer available, including for any otherwise available renewals, extensions or conversions. Circuits already subject to a Switched Access Term Plan of greater than 36 months, as of March 1, 2019, will continue to be provided under that plan for the remainder of that term. (N)

(This page filed under Transmittal No. 567)

Issued: February 14, 2019

Effective: March 1, 2019

ACCESS SERVICE

6. Switched Access Service (Cont'd)
 6.8 Rates and Charges (Cont'd)
 6.8.2 Switched Transport

(A) Entrance Facilities (Per Point of Termination) (Cont'd)

(4) Fiber AdvantageSM DS3 and DS3x3 Rate Stability
 Payment Plan (Cont'd)

	<u>USOC</u>	<u>Monthly Rates</u>	<u>Nonrecurring Charges</u>
(c) <u>5 Year Plan</u> ⁽¹⁾ (Cont'd)			(C)
- Fiber Advantage SM DS3x12 with Terminal Equipment			
Zone 1	Z3MSW/Z25SE	\$3,780.00	\$0,000.00#
Zone 2	Z3MSW/Z25SE	3,780.00	0,000.00#
Zone 3	Z3MSW/Z25SE	4,200.00	0,000.00#
- Fiber Advantage SM DS3x12 without Terminal Equipment			
Zone 1	Z0MSW/Z25S0	2,268.00	0,000.00#
Zone 2	Z0MSW/Z25S0	2,268.00	0,000.00#
Zone 3	Z0MSW/Z25S0	2,520.00	0,000.00#
(5) 274.176 Mbps	TWT++	ICB**	ICB**
- Fiber Advantage OE48 with Equipment			
Zone 1	Z3MSW		
Zone 2 S53	Z3MSW		
Zone 3	Z3MSW		
- Fiber Advantage OE48 without Equipment			
Zone 1	Z0MSW		
ZONE 2 S53	Z0MSW		
Zone 3	Z0MSW		

** ICB rates and charges are filed in 7.6 following.

Nonrecurring charges associated with the installation of Fiber AdvantageSM Service under a 5 year⁽¹⁾ Rate Stability Plan are waived. (C)

Rates contained in this transmittal are subject to subsequent adjustment, effective retrospectively, in the event the Commission or a court subsequently authorizes Pacific to correct its rates pursuant to pending motions, or petitions for reconsideration or waiver, or in the event of any other adjustment to an order of the Commission or a court.

(1) Effective on March 1, 2019, Switched Access Term Plans of greater than 36 months are no longer available, including for any otherwise available renewals, extensions or conversions. Circuits already subject to a Switched Access Term Plan of greater than 36 months, as of March 1, 2019, will continue to be provided under that plan for the remainder of that term. (N)

(This page filed under Transmittal No. 567)

Issued: February 14, 2019

Effective: March 1, 2019

ACCESS SERVICE

6. Switched Access Service (Cont'd)

6.8 Rates and Charges (Cont'd)

6.8.2 Switched Transport (Cont'd)

(B) Direct-Trunked Transport

<u>Rate</u>	<u>USOC</u>	<u>ZONE</u>	<u>Monthly</u>	
			<u>Fixed</u>	<u>Per Mile</u>
(1) Voice Grade per transport channel				
0 Miles	1L5SW	1	None	None
Over 0 Miles	1L5SW	1	2.63	0.38
0 Miles	1L5SW	2	None	None
Over 0 Miles	1L5SW	2	2.70	0.41
0 Miles	1L5SW	3	None	None
Over 0 Miles	1L5SW	3	1.97	0.34
(2) DS1 per transport channel				
0 Miles	1L5SW	1	None	None
Over 0 Miles	1L5SW	1	29.21	3.75
0 Miles	1L5SW	2	None	None
Over 0 Miles	1L5SW	2	29.46	3.76
0 Miles	1L5SW	3	None	None
Over 0 Miles	1L5SW	3	29.80	3.76
(3) DS3 per facility				
0 Miles	1L5SW	1	None	None
Over 0 Miles	1L5SW	1	215.00 (I)	11.75 (I)
0 Miles	1L5SW	2	None	None
Over 0 Miles	1L5SW	2	234.00 (I)	11.90 (I)
0 Miles	1L5SW	3	None	None
Over 0 Miles	1L5SW	3	244.50 (I)	12.05 (I)

Rates contained in this transmittal are subject to subsequent adjustment, effective retrospectively, in the event the Commission or a court subsequently authorizes Pacific to correct its rates pursuant to pending motions, or petitions for reconsideration or waiver, or in the event of any other adjustment to an order of the Commission or a court.

(This page filed under Transmittal No. 355)

Issued: June 15, 2007

Effective: June 30, 2007

Four AT&T Plaza, Dallas, Texas 75202

ACCESS SERVICE

6. Switched Access Service (Cont'd)

6.8 Rates and Charges (Cont'd)

6.8.2 Switched Transport (Cont'd)

(C) Tandem Switched Transport

(1) Tandem Switched Transmission

	<u>ZONE</u>	<u>Originating</u> <u>8YY</u>	<u>Originating</u> <u>Non-8YY</u>	<u>Terminating to</u> <u>non-Telephone</u> <u>Company 3rd</u> <u>party location</u>	<u>Terminating</u> <u>to Telephone</u> <u>Company's</u> <u>own end</u> <u>office</u>	(C)
<u>Termination</u>						
Fixed per Access						
Minute of Use						
0 Miles	1	None	None	None	None	
Over 0 Miles	1	\$.000000 (R)	\$.000000 (N)	\$.000075	\$0.00	
FGA Over 0 Miles	1	.000000 (R)	.000000 (N)	.000068	\$0.00	
0 Miles	2	None	None	None	None	
Over 0 Miles	2	.000000 (R)	.000000 (N)	.000130	\$0.00	
FGA Over 0 Miles	2	.000000 (R)	.000000 (N)	.000076	\$0.00	
0 Miles	3	None	None	None	None	
Over 0 Miles	3	.000000 (R)	.000000 (N)	.000240	\$0.00	
FGA Over 0 Miles	3	.000000 (R)	.000000 (N)	.000084	\$0.00	
<u>Facility</u>						
Per Mile per Access						
Minute of Use						
0 Miles	1	None	None	None	None	
Over 0 Miles	1	.000000 (R)	.000000 (N)	.000015	\$0.00	
FGA Over 0 Miles	1	.000000 (R)	.000000 (N)	.000007	\$0.00	
0 Miles	2	None	None	None	None	
Over 0 Miles	2	.000000 (R)	.000000 (N)	.000025	\$0.00	
FGA Over 0 Miles	2	.000000 (R)	.000000 (N)	.000007	\$0.00	
0 Miles	3	None	None	None	None	
Over 0 Miles	3	.000000 (R)	.000000 (N)	.000044	\$0.00	
FGA Over 0 Miles	3	.000000 (R)	.000000 (N)	.000007	\$0.00	
(2) Tandem Switching	1	.000892 (I)	.000892 (N)	.000440	\$0.00	
per Access Minute						
Tandem Switching		.000892 (R)	.000892 (N)	.001042	\$0.00	
per Access Minute	2					
Tandem		.000892 (R)	.000892 (N)	.001750	\$0.00	
Switching per	3					
Access Minute						
(D) <u>Reserved for Future Use</u>						
(E) <u>Reserved for Future Use</u>						

(This page filed under Transmittal No. 584)

ACCESS SERVICE

6. Switched Access Service (Cont'd)

6.8 Rates and Charges (Cont'd)

6.8.2 Switched Transport (Cont'd)

(F) Tandem Switched Transport/Common Transport

	<u>ZONE</u>	<u>Originating</u> <u>8YY</u>	<u>Originating</u> <u>Non-8YY</u>	<u>Terminating to</u> <u>non-Telephone</u> <u>Company 3rd</u> <u>party location</u>	<u>Terminating to</u> (C) <u>Telephone</u> <u>Company's</u> <u>own end office</u>
(1) <u>Host Remote</u>					
<u>Transmission</u>					
Rate per Access Minute	1	\$.000000 (R)	\$.000000 (N)	N/A	\$0.00
	2	\$.000000 (R)	\$.000000 (N)	N/A	\$0.00
	3	\$.000000 (R)	\$.000000 (N)	N/A	\$0.00
Rate per Access Minute per mile	1	\$.000000 (R)	\$.000000 (N)	N/A	\$0.00
	2	\$.000000 (R)	\$.000000 (N)	N/A	\$0.00
	3	\$.000000 (R)	\$.000000 (N)	N/A	\$0.00
(2) <u>Tandem End Office</u>					
<u>Multiplexing</u>					
Rate per Access Minute		\$.000000 (R)	\$.000000 (N)	\$.000098	\$0.00 (C)
	<u>USOC</u> <u>Effective</u> <u>Until</u> <u>6/10/2013</u>	<u>Originating</u> <u>USOC</u> <u>Effective</u> <u>6/10/2013</u>	<u>Originating</u> <u>Monthly</u> <u>Rate</u>	<u>Terminating</u> <u>USOC</u> <u>Effective</u> <u>6/10/2013</u>	<u>Terminating</u> <u>Monthly</u> <u>Rate</u>
(3) <u>Dedicated Tandem</u>					
<u>Trunk Port</u>					
Per Port	PT8LX/DTRPT	3PO3X	\$3.70	3PT3X	\$3.70

Rates contained in this transmittal are subject to subsequent adjustment, effective retrospectively, in the event the Commission or a court subsequently authorizes Pacific to correct its rates pursuant to pending motions, or petitions for reconsideration or waiver, or in the event of any other adjustment to an order of the Commission or a court.

(This page filed under Transmittal No. 584)

Issued: June 16, 2021

Effective: July 1, 2021

Four AT&T Plaza, Dallas, Texas 75202

ACCESS SERVICE

6. Switched Access Service (Cont'd)

6.8 Rates and Charges (Cont'd)

6.8.2 Switched Transport (Cont'd)

(G) Installation Per Order

	USOC	First	Nonrecurring Charges Additional	
- Per line for FGA, ALA traversing Direct Trunked Transport	TPP++	\$540.00	\$550.00	(C)
- Per trunk for FGB, ATA-950, FGD, ATA-101XXXX or 8yy Access Service traversing Direct Trunked Transport	TPP++	450.00	132.44	(C) (T) (D)

(H) Rollovers

- Per Point of Termination with No Change in Point of Termination				
DS3	NRBE6/SVRSW	498.00	350.00	
DS1	NRBE6/SVRSW	192.50	77.00	
DSO/VG	NRBE7/SVRDO	203.00	45.00	
FGA Line	NRBE8/SVRFA	352.00	200.00	
- Per Point of Termination with Change in Point of Termination				
DS3	NRBEJ/SVRST	696.00	350.00	
DS1	NRBEJ/SVRST	192.50	77.00	
DSO/VG	NRBE9/SVRDT	429.00	183.00	
FGA Line	NRBEK/SVRFT	352.00	200.00	

(This page filed under Transmittal No. 361)

ACCESS SERVICE

6. Switched Access Service (Cont'd)

6.8 Rates and Charges (Cont'd)

6.8.2 Switched Transport (Cont'd)

(I) Optional Features

(1) Supervisory Signaling

FID

DX Supervisory Signaling arrangement				
- Per trunk group***	NCI	++DX+		
SF Supervisory Signaling arrangement				(C)
- Per trunk group#	NCI	++SF+		
E&M Type I Supervisory Signaling arrangement				(C)
- Per trunk group***	NCI	++EA+		
E&M Type II Supervisory Signaling arrangement				(C)
- Per trunk group***	NCI	++EB+		
E&M Type III Supervisory Signaling				(C)
- Per trunk group*	NCI	++EC+		
Tandem Supervisory Signaling				(C)
- Per line group**	NCI	++EX+		

* Available with Interface Group 2 for FGD.

** Available with Interface Group 2 for FGA.

*** Available with Interface Groups 1 and 2.

Available with Interface Groups 1, 2, 5, 6 and 9.

(D)

(This page filed under Transmittal No. 361)

Issued: July 26, 2007

Effective: August 10, 2007

Four AT&T Plaza, Dallas, Texas 75202

ACCESS SERVICE

6. Switched Access Service (Cont'd)

6.8 Rates and Charges (Cont'd)

6.8.2 Switched Transport (Cont'd)

(J) <u>Non Chargeable Optional Features</u> (Cont'd)	<u>FID</u>
(2) Customer specification of the receive transmission level at the first point of switching within a range acceptable to the Telephone Company - Per Transport Channel Path***	TLV
(3) Customer specification of Local Transport Termination Four-wire termination in lieu of two-wire termination - Per Transport Channel Path****	NC S+T+
(4) Common Channel Signaling (CCSAC)	CCS7
(5) Tandem Signaling (MF or SS7)	

*** Available with Interface Groups 2, 5, 6 and 9 for FGA and FGB. The range of transmission levels which may be specified is described in Technical Reference TR-NWT-000334.

**** Available with Feature Group B with Type B Transmission Specification.

(This page filed under Transmittal No. 1)

ACCESS SERVICE

6. Switched Access Service (Cont'd)

6.8 Rates and Charges (Cont'd)

6.8.2 Switched Transport (Cont'd)

(K) Chargeable Optional Features

Rate

- (D)
- (D)
- (1) Multiplexing - per Arrangement (T)

	<u>USOC</u>	<u>ZONE</u>	<u>Monthly Nonrecurring Rate</u>	<u>Charges</u>
DS3 to DS1				
- Per Arrangement	MQ3SW	1	\$281.00	None
- Per Arrangement	MQ3SW	2	283.04	None
- Per Arrangement	MQ3SW	3	285.50	None
DS1 to Voice/Digital				
Option 1	MQ1SW	1	170.00	None
Option 2	MQ2SW	1	170.00	None
DS1 to Voice/Digital				
Option 1	MQ1SW	2	170.00	None
Option 2	MQ2SW	2	170.00	None
DS1 to Voice/Digital				
Option 1	MQ1SW	3	170.00	None
Option 2	MQ2SW	3	170.00	None

- (2) Carrier Identification Parameter (CIP) (T)

	<u>USOC</u>	<u>Monthly Nonrecurring Rate</u>	<u>Charge</u>
- Per Trunk Group	C1PAT	\$45.50	None

(This page filed under Transmittal No. 550)

ACCESS SERVICE

6. Switched Access Service (Cont'd)

6.8 Rates and Charges (Cont'd)

6.8.3 Local Switching for Feature Groups

	Originating 8YY Monthly Rate	Originating Non-8YY Monthly Rate	Terminating Monthly Rate	
<u>(A) Usage Sensitive Rates</u>				
<u>Premium Rates</u>				
LS1 - Feature Groups A and B except for FGA and FGB used to terminate traffic to a WAL.	\$ 0.000000	\$ 0.000000	\$ 0.00	(R)
LS2 - Feature Group D, Toll Free Access Service, FGA and FGB used to terminate traffic to a WAL and originating FGB routed to FGD as specified in Section 6.2.4(A) (9), preceding.	\$ 0.000000	\$ 0.000000	\$ 0.00	(R)
	<u>Originating USOC</u>	<u>Originating Monthly Rate</u>	<u>Terminating USOC</u>	<u>Terminating Monthly Rate</u>
(B) <u>Dedicated End Office Trunk Port</u> Per Port	3PO1X	\$ 11.08	3PT1X	\$ 0.00
(C) <u>Shared End Office Trunk Port</u> Per Minute of Use, 8YY		\$ 0.000000		\$ 0.00 (R)
Per Minute of Use, Non-8YY		\$ 0.000000		\$ 0.00 (R)
(D) <u>Feature Group A Line Port</u> Per Port		\$ 10.00		\$ 0.00

(This page filed under Transmittal No. 593)

Issued: June 16, 2023

Effective: July 1, 2023

ACCESS SERVICE

6. Switched Access Service (Cont'd)

6.8 Rates and Charges (Cont'd)

6.8.3 Local Switching for Feature Groups (Cont'd)

(E) Common Switching Non-Chargeable Optional Features Used with Feature Groups

	<u>FID</u>	(T)
Call Denial on Line or Hunt Group (available with FGA) - Per Line or Line Group	CAD	
Service Code Denial on Line or Hunt Group (available with FGA) - Per Line or Line Group	SCD	(C)
Hunt Group Arrangement (available with FGA) - Per Line Group	HML/HTG	(C)
Uniform Call Distribution Arrangement (available with FGA) - Per Line Group	UCD	(C)
Nonhunting Number for Use with Hunt Group Arrangement or Uniform Call Distribution Arrangement (available with FGA) -Per Line	NHN	(C)

(This page filed under Transmittal No. 361)

ACCESS SERVICE

6. Switched Access Service (Cont'd)

6.8 Rates and Charges (Cont'd)

6.8.3 Local Switching for Feature Groups (Cont'd)

(E) Common Switching Non-Chargeable Optional Features Used with Feature Groups (Cont'd)

	<u>FID</u>	
Automatic Number Identification (available with FGB and FGD)		
- Per Trunk Group	ANI	(D) (C)
Up-to-10-Digit Outpulsing of Access Digits to IC (available with FGB)		
- Per Trunk Group	USDO	(C)
Cut-through (available with FGD)		(C)
- Per End Office or Access Tandem	CTO	
		(D) (D) (D)
		(D) (D) (D)
		(D) (D) (D)

(This page filed under Transmittal No. 361)

ACCESS SERVICE

6. Switched Access Service (Cont'd)

6.8 Rates and Charges (Cont'd)

6.8.3 Local Switching for Feature Groups (Cont'd)

(E) Common Switching Non-Chargeable Optional Features Used with Feature Groups (Cont'd)

	<u>FID</u>	
		(T)
		(D)
		(D)
		(D)
		(D)
		(D)
		(D)
		(D)
Service Class Routing (available with FGD)		(D)
- Per Trunk Group	SCRT	(D)
Alternate Traffic Routing		(C)
- Multiple Customer Premises Alternate Routing (available with FGB and FGD)		(D)
- Per Trunk Group		(D)
- End Office Alternate Routing When Ordered in trunks (available with FGB and FGD)		(C)
- Per Trunk Group	ARTG	(T)
		(D)
		(C)

(This page filed under Transmittal No. 361)

ACCESS SERVICE

6. Switched Access Service (Cont'd)6.8 Rates and Charges (Cont'd)6.8.3 Local Switching for Feature Groups (Cont'd)(E) Common Switching Non-Chargeable Optional Features Used with Feature Groups (Cont'd)

	<u>FID</u>	
Band Advance Arrangement for Use with the WATS Access Line Service (available with FGD) - Per Arrangement	BAAD	(T)
End Office End User Line Service Screening for Use with originating only WATS Access Line Service (available with FGD) - Per WATS Access Line	BAND	(D)
Hunt Group Arrangement for Use with WATS Access Line Service (available with FGD) - Per WATS Access Line Group	HML/HTG	(D)
Trunk Access Limitation Arrangement (available with FGD) - Per End Office	CHOK	(D)
Call Gapping Arrangement (available with FGD) - Per End Office	CGAP	(D)
International Carrier Option (available with FGD) - Per End Office and Access Tandem	INCO	

(This page filed under Transmittal No. 371)

ACCESS SERVICE

6. Switched Access Service (Cont'd)

6.8 Rates and Charges (Cont'd)

6.8.3 Local Switching for Feature Groups (Cont'd)

(E) Common Switching Non-Chargeable Optional Features Used with Feature Groups (Cont'd)

	<u>FID</u>	
Uniform Call Distribution Arrangement for Use with WATS Access Line Service (available with FGD) - Per WATS Access Line Group	HTY UD	(T)
Nonhunting Number for Use with Hunt Group Arrangement or Uniform Call Distribution Arrangement for Use with WATS Access Line Service (available with FGD) - Per WATS Access Line	NHN	(D)
LATA-Wide Terminating Access (Available with FGB) - Per Trunk Group	LWTA	(D)
		(C)

(This page filed under Transmittal No. 361)

ACCESS SERVICE

6. Switched Access Service (Cont'd)

6.8 Rates and Charges (Cont'd)

6.8.3 Local Switching for Feature Groups (Cont'd)

(E) Common Switching Non-Chargeable Optional Features Used with Feature Groups (Cont'd)

	<u>USOC</u>
Calling Party Number (CPN)	
- Per customer per switch	NR4CP/SLCPN
Charge Number (CN)	
- Per customer per switch	SLCHG
Carrier Selection Parameter (CSP)	
- Per customer per switch	NR4CS/SLCSP
Access Transport Parameter (ATP)	
- Per customer per switch	

(F) Common Switching Chargeable Optional Feature Used with Feature Groups

	<u>Rate</u>	
Public Switched Digital Service Access Switching Capability		
- per access minute (for one minute or any fraction thereof, the charge of one access minute applies)	\$0.00	(R)

(G) Switched Transport Termination Nonchargeable Options

(1) Line-Side Terminations (For FGA)	<u>FID</u>
Two-Way Operation	
- Dial Pulse with Loop Start	NC +++A
- Dial Pulse with Ground Start	NC +++E
- DTMF with Loop Start	NC +++F
- DTMF with Ground Start	NC +++G

(This page filed under Transmittal No. 507)

ACCESS SERVICE

6. Switched Access Service (Cont'd)

6.8 Rates and Charges (Cont'd)

6.8.3 Local Switching for Feature Groups (Cont'd)

(G) Switched Transport Termination Nonchargeable Options (Cont'd)

(1) Line-Side Terminations (For FGA) (Cont'd)

(T)

	<u>FID</u>
Terminating Operation	
- Dial Pulse with Loop Start	NC +++N
- Dial Pulse with Ground Start	NC +++P
- DTMF with Loop Start	NC +++R
- DTMF with Ground Start	NC +++S
Originating Operation	
- Loop Start	NC +++U
- Ground Start	NC +++V

(For FGB and FGD)

Standard Trunk for Originating,
 Terminating or Two-Way operation
 (available with FGB and FGD)

TTC SO
 TTC ST
 TTC TY

(D)

Rotary-Dial Station Signaling
 Trunk (available with FGB)

TTC RD

(D)

Operator Trunks - MOS
 Coin or Combined Coin and Non-Coin
 (available with FGD)

TTC CO
 TTC CC

(D)

(D)

(D)

(D)

Operator Trunks - EAOSS
 (available with FGD)

TTC FF

(This page filed under Transmittal No. 371)

ACCESS SERVICE

6. Switched Access Service (Cont'd)

6.8 Rates and Charges (Cont'd)

6.8.3 Local Switching for Feature Groups (Cont'd)

(G) Switched Transport Termination Nonchargeable Options (Cont'd)

(2) Trunk-Side Terminations

(T)

FID

Operator Trunks, Full
Feature Arrangement
(available with FGD)

TTC FF

(This page filed under Transmittal No. 371)

Issued: September 6, 2007

Effective: September 22, 2007

Four AT&T Plaza, Dallas, Texas 75202

ACCESS SERVICE

6. Switched Access Service (Cont'd)

6.8 Rates and Charges (Cont'd)

6.8.4

6.8.5 Local Switching for Access Arrangements

<u>(A) Usage Sensitive Rates</u>	<u>Originating</u> <u>8YY</u>	<u>Originating</u> <u>Non-8YY</u>	<u>Terminating</u>	(C)	
<u>Premium Rates</u>					
<u>Rate Per Access Minute</u>					
LS1A - ALA and ATA-950 except for ALA and ATA-950 used to terminate traffic to a WAL	Rate is provided in Section 6.8.3(A)	Rate is provided in Section 6.8.3(A)	Rate is provided in Section 6.8.3(A)		
LS2D - ATA-10XXX, ALA and ATA-950 used to terminate traffic to a WAL	Rate is provided in Section 6.8.3(A)	Rate is provided in Section 6.8.3(A)	Rate is provided in Section 6.8.3(A)		
	<u>Originating</u> <u>USOC</u>	<u>Terminating</u> <u>USOC</u>			
<u>(B) Dedicated End Office</u> <u>Trunk Port</u>					
Per Port	3P01X	3PT1X	Rate is provided in Section 6.8.3(B)		
<u>(C) Shared End Office</u> <u>Trunk Port</u>					
Rate per Access Minute	Rate is provided in Section 6.8.3(C)	Rate is provided in Section 6.8.3(C)	Rate is provided in Section 6.8.3(C)		
					(C)

(This page filed under Transmittal No. 584)

ACCESS SERVICE

6. Switched Access Service (Cont'd)

6.8 Rates and Charges (Cont'd)

6.8.5 Local Switching for Access Arrangements (Cont'd)

(B) Common Switching Optional Features Used with Access Arrangements

	<u>FID/USOC</u>	<u>Monthly Nonrecurring Rate</u>	<u>Charge</u>	
Call Denial on line or Hunt Group (Available with ALA)	CAD/			
- Per Line	CF3CD/BEDCA	\$0.00	None	(R)
Service Code Denial on Line (Available with ALA)	SCD/			
- Per Line	CF3SD/SVCCD	0.00	None	(R)
Hunt Group Arrangement (Available with ALA)	HML,HTG/			
- Per Line	CF3HG/MLHTG	0.00	None	(R)
Hunt Group Arrangement for Use with WATS Access Lines (Available with ATA-101XXXX)				
- Per WATS Access Line Group	HML,HTG	None	None	
Uniform Call Distribution (Available with ALA)	CF3UC/UCD			
- Per Line	CDUHT	None	0.00	(R)

(This page filed under Transmittal No. 507)

ACCESS SERVICE

6. Switched Access Service (Cont'd)

6.8 Rates and Charges (Cont'd)

6.8.5 Local Switching for Access Arrangements (Cont'd)

(B) Common Switching Optional Features Used with Access Arrangements (Cont'd)

	<u>FID/USOC</u>	<u>Monthly Nonrecurring Rate</u>	<u>Charge</u>	
—				
Nonhunting Number for Use with Hunt Group or Uniform Call Distribution (Available with ALA)	NHN/ MLHPT	None	None	
- Per Line				
Automatic Number Identification (ANI) (Available with ATA- 101XXXX and ATA-950)	ANI/ BEAN1	\$0.00	None	(R)
- Per Message				
Up-to-10-Digit Outpulsing of Access Digits to IC (available with ATA-950)	USDO	None	None	
- Per Trunk Group				
Cut-Through (Available with ATA-101XXXX)	CTO	None	None	
- Per End Office or Access Tandem				
Service Class Routing (Available with ATA- 101XXXX)	SCRT	None	None	
- Per Trunk Group				
Answer Supervision - Lineside (Available with ALA)	ANSPF	ICB	ICB	
- Per Line				

(This page filed under Transmittal No. 507)

ACCESS SERVICE

6. Switched Access Service (Cont'd)

6.8 Rates and Charges (Cont'd)

6.8.5 Local Switching for Access Arrangements (Cont'd)

(B) Common Switching Optional Features Used with Access Arrangements (Cont'd)

	<u>FID/USOC</u>	<u>Monthly Nonrecurring</u>		
		<u>Rate</u>	<u>Charge</u>	
—				
Alternate Traffic Routing Multiple Customer Premises Alternate Routing (Available with ATA-950 and ATA-101XXXX)				(D)
- Per Trunk Group	ARTG	None	None	(C)
Alternate Traffic Routing End Office Alternate Routing When Ordered in Trunks (Available with ATA-950 and ATA-101XXXX)				(D)
- Per Trunk Group	ARTG	None	None	(C)
Trunk Access Limitation Arrangement (Available with ATA-101XXXX)				
- Per End Office	CHOK	None	None	
Call Gapping Arrangement (Available with ATA- 101XXXX)				
- Per End Office	CGAP	None	None	
Band Advance Arrangement for Use with the WATS Access Line Service (available with ATA- 101XXXX)				
- Per Arrangement	BAAD	None	None	

(This page filed under Transmittal No. 361)

ACCESS SERVICE

6. Switched Access Service (Cont'd)

6.8 Rates and Charges (Cont'd)

6.8.5 Local Switching for Access Arrangements (Cont'd)

(B) Common Switching Optional Features Used with Access Arrangements (Cont'd)

	<u>FID/USOC</u>	<u>Monthly Nonrecurring Rate</u>	<u>Charge</u>	
	-			
End Office End User Line Service Screening for Use with originating only WATS Access Line Service* (available with ATA- 101XXXX)				
- Per WATS Access Line	BAND	None	None	
International Carrier Option (Available with ATA-101XXXX)				
- Per End Office and Access Tandem	INCO/	None	None	
Public Switched Digital Switching Service Capability (Available with ATA-101XXXX)				
- Per Access Minute (For one minute or any fraction thereof, the charge of one access minute applies)		\$0.00	None	(R)
Uniform Call Distribution Arrangement for Use with WATS Access Lines (Available with ATA- 101XXXX)				
- Per WATS Access Line Group	HTY-UD/	None	None	

(This page filed under Transmittal No. 507)

ACCESS SERVICE

6. Switched Access Service (Cont'd)

6.8 Rates and Charges (Cont'd)

6.8.5 Local Switching for Access Arrangements (Cont'd)

(B) Common Switching Optional Features Used with Access Arrangements (Cont'd)

	<u>FID/USOC</u>	<u>Monthly Nonrecurring Rate</u>	<u>Charge</u>	
Nonhunting Number for Use with Hunt Group or Uniform Call Distribution Arrangement for Use with WATS Access Lines (Available with ATA- 101XXXX)	-			
- Per WATS Access Line	NHN	None	None	
LATA-Wide Terminating Access (Available with ATA-950)				
- Per Trunk Group	LWTA			
Hunt Group - Overflow (Available with ALA)				
- Per Line	MLHOF	None	None	
Uniform Call Distribution with Queuing (Available with ALA)				
- Per Line	CF3UQ/CDUQG	\$0.00	None	(R)
Hunt Group - C.O Announcement (Available with ALA)				
- Per Arrangement	CF3HA/MLHCO	\$0.00	None	(R)
Three Way Call Transfer (Available with ALA)				
- Per Line	TRC3W	0.00	None	(R)

(This page filed under Transmittal No. 507)

ACCESS SERVICE

6. Switched Access Service (Cont'd)6.8 Rates and Charges (Cont'd)6.8.5 Local Switching for Access Arrangements (Cont'd)(B) Common Switching Optional Features Used with Access Arrangements (Cont'd)

	<u>USOC</u>	<u>Monthly Nonrecurring</u>		
		<u>Rate</u>	<u>Charge</u>	
	—			
Make Busy Key - per arrangement	FCP89	\$ 0.00	\$ 0.00	(R)
Forwarded Call Information	FCLMF	0.00	0.00	(R)
Network Forwarded Call Information (NFCI)	MN1XX	0.00	0.00	(R)
NFCI With Alternate Network Delivery	MN1AN	0.00	0.00	(R)
NFCI - Multiple User	M2NXX	0.00	0.00	(R)
NFCI - Multiple User With Alternate Network Delivery	M2NAN	0.00	0.00	(R)
Activate Message Waiting Indicator - Audible	MW1AD	0.00	0.00	(R)
Activate Message Waiting Indicator - Visual	MW1VS	0.00	0.00	(R)
Calling Party Number (CPN) - Per message	NR4CP/SLCPN	NONE	NONE	

(This page filed under Transmittal No. 507)

Issued: June 16, 2014

Effective: July 1, 2014

Four AT&T Plaza, Dallas, Texas 75202

ACCESS SERVICE

6. Switched Access Service (Cont'd)

6.8 Rates and Charges (Cont'd)

6.8.5 Local Switching for Access Arrangements (Cont'd)

(B) Common Switching Optional Features Used with Access Arrangements (Cont'd)

	<u>USOC</u>	<u>Monthly Nonrecurring Rate</u>	<u>Charge</u>	
	—			
Charge Number (CN)**				
- Per message	SLCHG	0.00	NONE	(R)
Carrier Selection Parameter (CSP)**				
- Per customer per switch	NR4CS/SLCSP	NONE	NONE	
Access Transport Parameter (ATP)**				
- Per customer per switch		NONE	NONE	
Calling Number Delivery via ICLID (Available with ALA)	XXXXXX	NONE	NONE	

** Available only with ATA-101XXXX with the CCSAC optional feature.

(This page filed under Transmittal No. 507)

ACCESS SERVICE

6. Switched Access Service (Cont'd)6.8 Rates and Charges (Cont'd)6.8.5 Local Switching for Access Arrangements (Cont'd)(C) Switched Transport Termination Options Used with Access Arrangements

	<u>FID</u>
(1) Line-Side Terminations for ALA	
Two-Way Operation	
- Dial Pulse with Loop Start	NC +++A
- Dial Pulse with Ground Start	NC +++E
- DTMF with Loop Start	NC +++F
- DTMF with Ground Start	NC +++G
Terminating Operation	
- Dial Pulse with Loop Start	NC +++N
- Dial Pulse with Ground Start	NC +++P
- DTMF with Loop Start	NC +++R
- DTMF with Ground Start	NC +++S
Originating Operation	
- Loop Start	NC +++U
- Ground Start	NC +++V
(For ATA-950 and ATA-101XXXX)	
Standard Trunk for Originating, Terminating or Two-Way operation (available with ATA-950 and ATA-101XXXX)	TTC SO TTC ST TTC TY
Rotary-Dial Station Signaling Trunk (available with ATA-950)	TTC RD
Operator Trunks - MOS Coin or Combined Coin and Non- Coin (available with ATA-101XXXX)	TTC CO TTC CC
Operator Trunks - EAOSS (available with ATA-101XXXX)	TTC FF

(This page filed under Transmittal No. 1)

ACCESS SERVICE

6. Switched Access Service (Cont'd)

6.8 Rates and Charges (Cont'd)

6.8.5 Local Switching for Access Arrangements (Cont'd)

(C) Switched Transport Termination Options Used with Access Arrangements (Cont'd)

	<u>FID</u>
(2) Trunk-side Terminations	
Operator Trunk, Full Feature Arrangement (Available with ATA-101XXXX)	TTC-FF

(D) Dedicated Network Access Link

	<u>USOC</u>	<u>Monthly Nonrecurring Rate</u>	<u>Charge</u>
(1) Transport Termination			
- Per Point of termination			
- Two-Wire	T6E2X	*	*
- Four-Wire	T6E4X	*	*
(2) Transport Mileage			
- over 0 miles			
- Fixed	1L5XX	**	**
- Per Mile	1L5XX	**	**
(3) Optional Features and Functions			
(a) Conditioning			
- Per Point of Termination			
- C-Type	X1CPT	***	***
- Improved Attenuation Distortion	UHW	***	***
- Improved Envelope Delay Distortion	UHY	***	***

* See section 7.5.3(A) following for Rates.
 ** See section 7.5.3(B) following for Rates.
 *** See section 7.5.3(C) (2) following for Rates.

(T)

(This page filed under Transmittal No. 371)

ACCESS SERVICE

6. Switched Access Service (Cont'd)

6.8 Rates and Charges (Cont'd)

6.8.5 Local Switching for Access Arrangements (Cont'd)

(D) Dedicated Network Access Link (Cont'd)

(3) Optional Features and Functions (Cont'd)

	<u>USOC</u>	<u>Monthly Nonrecurring Charge</u>	
		<u>Rates</u>	<u>Charge</u>
(b) Improved Termination	—		
Per Point of Termination			
- four-wire	1RL4W	*	*
(c) Improved Return Loss for Effective Two-wire Transmission			
Per Point of Termination			
- Two-wire	1RL2W	**	**
(d) Data Capability			
Per Point of Termination	XDCPT	***	***
(e) Signaling Capability			
Per Point of Termination	XSS++	****	****

* See section 7.5.3(C) (3) following for rates.

** See section 7.5.3(C) (4) following for rates.

*** See section 7.5.3(C) (7) following for rates.

**** See section 7.5.3(C) (9) following for rates.

(This page filed under Transmittal No. 1)

ACCESS SERVICE

6. Switched Access Service (Cont'd)

6.8 Rates and Charges (Cont'd)

(D)

(D)

(This page filed under Transmittal No. 371)

Issued: September 6, 2007

Effective: September 22, 2007

Four AT&T Plaza, Dallas, Texas 75202

ACCESS SERVICE

6. Switched Access Service (Cont'd)

6.8 Rates and Charges (Cont'd)

6.8.6 <u>Message Unit Credit</u>	Per Originating <u>Access Minute</u>	
(A) For all exchanges in the San Francisco-East Bay, and the Los Angeles extended area	(\$.002745)	
(B) All other exchanges in California	(\$.002745)	
6.8.7 <u>Reserved</u>		
6.8.8 <u>Information Surcharge</u>		
(A) Information Surcharge Rates		
- Premium Rate Per Access Minute		(C)
Originating 8YY	\$.000000	(C)
Originating Non-8YY	\$.000000	(N)
Terminating	\$.000000	(N)

Rates contained in this transmittal are subject to subsequent adjustment, effective retrospectively, in the event the Commission or a court subsequently authorizes Pacific to correct its rates pursuant to pending motions, or petitions for reconsideration or waiver, or in the event of any other adjustment to an order of the Commission or a court.

(This page filed under Transmittal No. 584)

Issued: June 16, 2021

Effective: July 1, 2021

ACCESS SERVICE

6. Switched Access Service (Cont'd)

6.8 Rates and Charges (Cont'd)

6.8.9 Line Information Data Base (LIDB) Service

	<u>USOC</u>	<u>Per Query Charge</u>	<u>Nonrecurring Charge</u>
(A) LIDB Service Establishment - Per Originating Point Code	ABSPB	None	\$129.00
(B) LIDB Transport-Per Query		\$.000270	None
(C) LIDB Validation-Per Query		.027000	None
(D) LIDB OLNS Query		.006730 (R)	None

6.8.10 SS7 Interconnection

	<u>ZONE</u>	<u>USOC</u>	<u>Monthly Rate</u>	<u>Nonrecurring Charge</u>
(A) SS7 Link - Each	1	SL7	\$ 96.00	\$590.00
	2	SL7	96.00	590.00
	3	SL7	96.00	590.00
(B) SS7 Link - per mile	1	SL7	.60	-
	2	SL7	.60	-
	3	SL7	.60	-
(C) STP Port - each	1	SLPTC	814.50	-
	2	SLPTC	814.50	-
	3	SLPTC	814.50	-

Rates contained in this transmittal are subject to subsequent adjustment, effective retrospectively, in the event the Commission or a court subsequently authorizes Pacific to correct its rates pursuant to pending motions, or petitions for reconsideration or waiver, or in the event of any other adjustment to an order of the Commission or a court.

(This page filed under Transmittal No. 73)

Issued: June 17, 2002

Effective: July 2, 2002

Four AT&T Plaza, Dallas, Texas 75202

ACCESS SERVICE

6. Switched Access Service (Cont'd)6.8 Rates and Charges (Cont'd)6.8.11 DID Switched Access Service

	<u>USOC</u>	<u>Monthly Nonrecurring</u>		
		<u>Rate</u>	<u>Charge</u>	
(A) DID PBX Trunk				
- Per Individual trunk	TMN	0.00	0.00	(R)
(B) DID Circuit Termination				
- Per individual trunk	TCT	0.00	None	(R)
(C) Blocks of Telephone Numbers				
- per 100 numbers	ND8	0.00	0.00	(R)
(D) Interoffice Mileage				
- Over 0 Miles				
- Fixed	1L5XX	*	*	
- Per mile	1L5XX	*	*	
(E) DID Trunk Queuing				
1. DID Trunk Queuing with First Announcement				
- Per Arrangement	A1QUE	\$ 0.00	\$ 0.00	(R)
2. Additional Announcement	A2QUE			
- Per Arrangement		0.00	0.00	(R)
3. Queue Slots				
- Per Slot	QSLOT	0.00	0.00	(R)
4. DID Number Conditioning for Use with DID Trunk Queuing				
- Per Group of 20 Numbers	TKQNC	0.00	0.00	(R)

*See Section 7.5.3(B) following for rates and charges.

(This page filed under Transmittal No. 507)

Issued: June 16, 2014

Effective: July 1, 2014

Four AT&T Plaza, Dallas, Texas 75202

ACCESS SERVICE

6. Switched Access Service (Cont'd)

6.8 Rates and Charges (Cont'd)

6.8.12 Toll Free Access

<u>Basic Toll Free Access Query</u>	<u>Recurring Charges</u>	
- Per query	\$0.000200	(R)
 <u>POTS Translation</u>		
- Per query	0.000000	
 <u>Multiple Destination Routing</u>		
- Per query	0.000000	
 <u>Six Digit Master Number List Turnaround</u>		
- Per query	0.000000	

6.8.13 Billing Name and Address (BNA) Service Rates

- Billing Name and Address Found, per listing	\$0.30
- Billing Name and Address Not Found, per listing	0.28

6.8.14 500 Access Service

	<u>USOC</u>	<u>Nonrecurring Charges</u>	
		<u>1st</u>	<u>Additional</u>
Activating/Deactivating Each NXX Per Central Office			
- Per Order	NRB5F/SACCH	\$0.00	\$0.00

(This page filed under Transmittal No. 593)

ACCESS SERVICE

6. Switched Access Service (Cont'd)

6.8 Rates and Charges (Cont'd)

6.8.15 Outbound Messaging Application

	<u>USOC</u>	<u>Monthly Rate</u>	<u>Nonrecurring Charge</u>
(A) Per LATA NPM \$6000.00			
(B) Per Point Code US4PL \$2000.00			
(C) Provisioning Charge per LATA NPM \$125.00			

(N)

(N)

(This page filed under Transmittal No. 285)

Issued: April 26, 2006

Effective: April 27, 2006

Four AT&T Plaza, Dallas, Texas 75202